

**ANTES DE COMENZAR, RECOPILE TODO EL MATERIAL DE APOYO PARA EL MONTAJE:** Instrucciones de montaje / ilustraciones paso a paso / planos y plantillas impresos a escala.

**PREPARACIÓN DEL MATERIAL:** Para poder identificar correctamente las piezas precortadas, antes de extraerlas de las planchas de madera, marque en ellas la misma numeración que aparece en la hoja "IP" (identificación de piezas), incluida en las instrucciones. El grueso de los tableros puede variar medio milímetro de más o de menos.

**INICIO DEL MONTAJE:** Con la ayuda de un cúter y procurando no colocar los dedos en la línea de corte, desprenda las piezas de las planchas eliminando los pequeños nervios que las sujetan. Seguidamente lije con suavidad las piezas con papel de lija de grano fino, para eliminar el repelo de las mismas. El orden numérico del paso a paso indica el orden de elaboración y colocación de las piezas. Es importante comprobar el ajuste de las piezas antes de pegarlas definitivamente.

**LISTONES Y VARILLAS:** Los modelos incorporan varios tipos de listones y varillas para elaborar las diferentes piezas. La lista de piezas proporciona información sobre el tipo de material y medidas. En algunos casos es conveniente ajustar las medidas sobre el propio modelo, conforme avanzamos en el montaje. De esta manera se consigue un mejor ajuste.

**PEGAMENTOS RECOMENDADOS:** Cola blanca o de carpintero. Para las uniones de piezas de madera y de todas aquellas piezas que no ofrezcan resistencia.

Pegamento rápido. Para piezas que sean difíciles de sostener y que necesiten un secado casi instantáneo.

Cola de contacto o de zapatero. Para todas aquellas piezas que se forren con chapas finas de madera o metal. En todos los casos, lea siempre las instrucciones de uso del fabricante.

**SERVICIO DE ATENCIÓN AL CLIENTE:** Para cualquier duda o información sobre el montaje de nuestros productos, puede contactar con nuestro Servicio Técnico en la dirección:

[www.occre.com](http://www.occre.com). Le atenderemos con mucho gusto.

**BEFORE STARTING, MAKE SURE YOU HAVE ALL THE SUPPORT MATERIAL FOR ASSEMBLING THE MODEL:**

Assembly Instructions / Step by step pictures / Plans and templates printed to scale.

**PREPARING THE MATERIAL:** In order to correctly identify the precut parts, before removing them from the wooden sheets, mark on them the same numbers that appear on the "IP"

(Part Identification) Sheet included with the instructions. The thickness of the boards can vary by half a millimeter more or less.

**STARTING THE ASSEMBLY:** Using a cutter, and making sure you do not put your fingers along the cutting line, remove the parts from the wooden sheets, eliminating the small sprues that hold them in place. In continuation smoothly sand down the parts, using fine grain sandpaper, to eliminate the pickup of the parts. The numerical order indicates the order in which the different parts must be made up and fitted.

**STRIPS AND RODS:** These models incorporate a variety of different types of strips and rods with which to make up the different parts of the kit. The list of parts proportions information on the type of material and measurements. In some cases it is advisable to adjust the measurements on the basis of the model itself, as assembly progresses. In this way you will achieve a better fit.

**RECOMMENDED GLUES:** White, or carpenter's glue: For joining pieces of wood together. Mainly used for gluing together the skeleton. Quick-drying glue. For parts that are difficult to hold in their final position and which need to set instantly. Recommended for fitting small parts. Contact or cobbler's glue. For gluing into place the parts that are covered with fine wood veneer to set instantly. In all cases, always follow the manufacturer's recommendations.

**CUSTOMER ATTENTION SERVICE:** In the case of whatsoever doubt or further information that you may require regarding the assembly of our products, please contact our Technical Service online at the address: [www.occre.com](http://www.occre.com). We will be delighted to attend to you.

**AVANT DE COMMENCER, VÉRIFIEZ TOUT LE MATÉRIEL DE SOUTIEN POUR LE MONTAGE:** Instructions de montage / Images étape par étape / Plans et modèles imprimés à l'échelle.

**PRÉPARATION DU MATÉRIEL:** Pour pouvoir identifier correctement les pièces prédécoupées, avant de les extraire des planches de bois, inscrivez sur elles la même numérotation qui apparaît sur la page « IP » (identification des pièces) comprise dans les instructions. L'épaisseur des planches peut varier d'un demi-millimètre plus ou moins.

**DÉBUT DU MONTAGE:** À l'aide d'un cutter, et en essayant de ne pas poser les doigts sur la ligne de découpe, séparez les pièces des planches en éliminant les petits nerfs qui les retiennent. Puis poncez doucement les pièces à l'aide d'un papier de verre à grain fin, pour éliminer le contrefil. L'ordre numérique des étapes photographiques et des plans indique l'ordre d'élaboration et d'installation des pièces.

**LISTEAUX ET BAGUETTES:** Les modèles intègrent plusieurs types de listeaux et de baguettes destinés à confectionner les différentes pièces. La liste des pièces indique le type de matériau et les dimensions des pièces. Il est parfois recommandé d'ajuster les mesures sur le modèle lui-même, au fur et à mesure que nous avançons dans le montage. De cette manière, on obtient un meilleur réglage.

**COLLES RECOMMANDÉES:** Colle blanche ou de menuisier: Pour les unions de pièces en bois et de toutes les pièces qui n'offrent pas de résistance. Colle à séchage rapide: Pour les pièces qui sont difficiles à maintenir dans leur position et qui requièrent un séchage pratiquement instantané. Colle de contact ou de cordonnier: Pour toutes les pièces qui sont recouvertes de fines plaques de bois ou de métal. Dans tous les cas, lisez toujours les instructions d'utilisation du fabricant.

**SERVICE CLIENT:** Pour toute question ou information concernant le montage de nos produits, vous pouvez contacter notre Service Technique à l'adresse suivante: [www.occre.com](http://www.occre.com).

Nous répondrons avec plaisir à vos questions.

**PRIMA D'INIZIARE, RIUNIRE TUTTO IL MATERIALE D'APPOGGIO PER IL MONTAGGIO:** Istruzioni di montaggio, immagini passo per passo, planimetrie e modelli stampati in scala.

**PREPARAZIONE DEL MATERIALE:** Per poter identificare in maniera corretta i pezzi che sono stati ritagliati, prima di estrarli dai blister di legno occorre segnarli con la stessa numerazione che è indicata nella pagina "IP" (Identificazione pezzi) che si trova nelle istruzioni. Lo spessore delle tavole può variare di mezzo millimetro in più o in meno.

**INIZIO DEL MONTAGGIO:** Con l'aiuto di un cutter, ed evitando di collocare le dita lungo la linea di taglio, separare i pezzi dai blister eliminando i piccoli nervi che li mantengono attaccati.

In seguito, scartare con delicatezza i pezzi, utilizzando una carta vetrata a grana fine, onde eliminare le sbavature degli stess. L'ordine numerico del passo per passo indica l'ordine d'elaborazione e di collocazione dei pezzi. È importante verificare che questi combacino bene, prima d'incollarli definitivamente.

**ASTE E BACCHETTE:** I modelli sono dotati di vari tipi di aste e bacchette per formare i diversi pezzi. L'elenco dei pezzi offre informazioni sul tipo di materiale e sulle misure. In alcuni casi è conveniente modificarne le misure quando sono sul modello, man mano che si avanza nel montaggio. In questo modo si potrà ottenere che combacino meglio.

**COLLE RACCOMANDATE:** Colla bianca o da falegname: Per unire tra loro i pezzi in legno e tutti quei pezzi che non presentino resistenza. Colla rapida: Per i pezzi difficili da sostenere e per i quali sia necessaria un'asciugatura quasi istantanea. Colla a contatto o da calzolaio: Per tutti quei pezzi che vengono rivestiti con fine lastre di legno o di metallo. In ogni caso, leggere sempre le istruzioni d'uso del produttore.

**SERVIZIO ASSISTENZA CLIENTE:** Per qualsiasi dubbio o informazione sul montaggio dei nostri prodotti, contattare il nostro Servizio Tecnico al seguente indirizzo: [www.occre.com](http://www.occre.com).

Seremo lieti di potervi aiutare.

**BEVOR SIE MIT DEM ZUSAMMENBAU BEGINNEN, LEGEN SIE SICH BITTE ALLE HILFSMATERIALIEN FÜR DIE MONTAGE BEREIT:**

Bastelanleitung / Maßstabgerechte Skizzen und Schablonen / Skizzen und Vorlagen.

**VORBEREITUNG DER MATERIALIEN:** Damit die einzelnen Bauteile korrekt zugeordnet werden können, empfehlen wir, auf den Holzplättchen vor dem Herausnehmen mit einem Bleistift die Nummer auf dem Blatt IP (Identifikation Teile) zu markieren. Die Dicke der Bretter kann um mehr oder weniger einen halben Millimeter variieren.

**BEGINN DES ZUSAMMENBAUS:** Die Teile mit einem Schneidwerkzeug (Cutter) herauslösen und die kleinen Befestigungsenden entfernen. Dabei darauf achten, die Finger nicht zu verletzen. Danach die Teile vorsichtig mit feinem Schmirgelpapier säubern, um ausgefranste Ränder zu entfernen. Die Nummernfolge der Schritte auf Fotos und Skizzen gibt an, in welcher Reihenfolge die Teile zusammengebaut werden.

**LEISTEN UND STÄBE:** Die Modelle enthalten mehrere Arten von Leisten und Stäben, aus denen die einzelnen Teile des Bausatzes geformt werden. In einigen Fällen kann es angebracht sein, die Maße im Zuge des Zusammenbaus entsprechend dem Modell anzupassen. Auf diese Weise wird eine bessere Passform erricht.

**EMPFOHLENE KLEBSTOFFE:** Weißleim (Tischlerleim): Zum Kleben von Strukturteilen und allen nachgiebigen Teilen. Sekundenkleber: Für schwer zu haltende Teile, die schnell verklebt werden müssen. Kontaktkleber (Schusterleim): Für alle Teile, die mit dünnen Holz- oder Metallstücken zum Beplanken oder Verkleiden beklebt werden. Bitte beachten Sie stets die Hinweise des Herstellers.

**UNSER KUNDENDIENST:** Bei Fragen zum Aufbau unserer Modelle steht Ihnen unser Kundendienst zur Verfügung. Sie erreichen uns online unter: [www.occre.com](http://www.occre.com).

Wir stehen Ihnen gern mit Rat und Tipps zur Verfügung.

**A.** Utilice una superficie plana y estable para pegar las piezas A1 y A2, y refuerce su unión con las piezas A3. Siguiendo el orden alfanumérico inserte y pegue las piezas indicadas en las figuras. Antes de encolar las cuadernas, verifique que encajan correctamente en su posición haciendo “tope” en los encajes correspondientes de la falsa quilla. Es importante que las cuadernas queden completamente perpendiculares a la falsa quilla para que posteriormente encajen bien las cubiertas. Para esta operación utilice como adhesivo cola blanca, (Ref.19200).

**B.** Corte las tiras de forro y destaque sus cantos con un lápiz. Comience a forrar la cubierta ajustando la primera chapa a la línea de lápiz que le indica la imagen. Pegue las chapas muy juntas para que no se noten las uniones. Utilice como adhesivo cola de contacto, (cola de zapatero). Frote las chapas contra la cubierta para que se adhieran con firmeza. Después, corte los sobrantes de las chapas con un cúter. Deje la parte trasera de la cubierta sin acabar. Forre las cubiertas que le indica la imagen. Después, lije y aplique barniz satinado, (Ref.19209), a las cubiertas pequeñas. Ajuste y pegue las cubiertas como le muestran las imágenes.

**C-D.** Complete el forro de la cubierta principal. Simule el claveteado de las tiras de forro con un lápiz. Después, lije y barnice la cubierta. Forre y barnice las cubiertas C1 y C2. Añada las piezas que le muestran las imágenes al casco. Coloque el casco boca abajo y comience a lijar empezando desde proa y avanzando hacia popa. Debe desbastar las aristas de las cuadernas, pero sin deformar su forma original. El lijado del casco ha de quedar simétrico, es decir, que el lateral derecho ha de quedar igual que el izquierdo. Para la zona media del casco, utilice un taco lijador con mayor superficie. El lijado debe ser progresivo y suave. Compruebe con un listón, que el lijado es correcto. Para ello, debe deslizar el listón, sobre las cuadernas, para ver como se ajusta a su forma. Ajuste y pegue las piezas D1.

**E-F-G-H.** Lije las piezas E1 y sumérlas en agua unos minutos para que recuperen flexibilidad. Después, utilice una pancha para aplicar calor y poder curvar las piezas. Ajuste y pegue las piezas E1 a ambos lados del casco. Corte a medida y añada las piezas E2 a las piezas E3, observe que deben ser simétricas. Después, pegue las piezas al casco. Proceda de la misma manera para fijar las piezas F1 y F2. Estas piezas ya puede clavarlas con las puntas A. Es recomendable utilizar un clavador, (Ref.19108), o en su defecto un martillo. Corte a medida y pegue las piezas F3 por la parte interior del casco. Asegúrese de que las pega con firmeza. En la parte delantera del casco no debe pegar las piezas F3. Presente la pieza F4 ajustada bajo las piezas F2. Pegue con cola blanca, (Ref.19200), las piezas F4. Después, fije su unión con puntas A. continúe el forro como le muestran las imágenes. Si los listones estuvieran muy secos y se le rompen al curvarlos, sumérlas en agua unos minutos. Con esta operación, recuperarán flexibilidad. Después, séquelos con un paño antes de pegarlos. Los demás listones del forro debe pegarlos a las cuadernas y entre sí, con cola blanca y fijarlos con puntas. Continúe pegando listones desde proa hasta popa para forrar el casco entero. Deberá cortar a medida y ajustar las piezas para que encajen en los huecos. Si en algún punto le ha quedado algún listón suelto, puede aplicar pegamento de secado rápido. Si le ha quedado algún listón más hundido, pegue otro encima y después, líjelo. Pegue las piezas H2 a H11. Lime las cabezas de las puntas con una lima plana hasta que queden enrasadas con el forro. Diluya un poco de cola blanca con agua para que pueda aplicarla ligeramente y se filtre entre las juntas de los listones. Reserve el casco hasta que la cola se seque. Con esta operación se unificará el forro del casco ganando así consistencia. Después, lije todo el casco. Debe quedar suave y sin desniveles.

**i-J.** Aplique cola de contacto, (cola de zapatero), a la zona del casco que le indican las imágenes. Encole y pegue las tiras de forro i1. Debe combinar tiras i1 para completar la longitud total del casco. Corte a medida las tiras de forro dependiendo de la necesidad. Frote las tiras de forro para que se adhieran con firmeza. Vaya eliminando las porciones de chapa que cubren los orificios de las troneras con un cúter. Continúe con el forrado del casco hacia arriba hasta sobrepasar las amuradas. Después, iguale el forro con los perfiles superiores de las amuradas. Proceda de la misma manera para forrar la parte inferior del casco con las piezas i2 e i3. Lije el forro del casco para dejarlo fino y sin desniveles. Tiña la parte interior de las amuradas con tinte de color pino, (Ref.19212). Ajuste y curve un listón J1 y péguelo de manera que tape la unión de los dos forros. Pegue las piezas J3 sobre las piezas J2. Aplique al panel obtenido, imprimación, (Ref.19142). Cuando se seque, pinte el panel de color negro, (Ref.19301). Después, destaque los relieves de las piezas con pintura de color blanco, (Ref.19300).

**K.** Aplique imprimación a la pared. Después pegue el panel de popa. Ajuste y pegue las piezas K1 a todo lo largo de la unión de la cubierta con las amuradas. Después, pegue las piezas K2 y K3 con el listón ranurado. Utilice esta herramienta, (Ref.19158) para ranurar las piezas. Ajuste y pegue las piezas K4 a K10.

**L.** Ajuste y pegue las piezas L1 a L5. Las piezas L1 y L2 deben quedar enrasadas con las piezas K8 a K10 por su parte inferior. Añada las piezas que le indican las imágenes. Después, forre las piezas L13 y L14 con el forro L15. Barnice el forro L15 una vez acabado. Vaya añadiendo las piezas que le indican las imágenes.

**M.** Ranure un listón de 2x3mm con la herramienta que le indica la imagen. Corte a medida y pegue las piezas M1 a M5. Utilice un objeto plano para enderezar el hilo de latón. Elabore y fije las piezas que le muestra la imagen.

**N-O.** Sitúe el barco sobre una superficie plana y estable. Utilice algún objeto para fijar un rotulador y marcar la línea de flotación a 75mm de la base. Debe realizar esta marca a todo el contorno del casco. Aplique barniz, (Ref.19209), a toda la parte inferior del casco, por debajo de la línea marcada. Pinte la parte superior del casco con pintura de color negro, (Ref.19301), excepto el interior de las amuradas y las cubiertas. Si no desea pintar el casco, tiña y barnice las piezas de los colores que le parezcan más adecuados. Elabore y fije las piezas que le indica la imagen. Utilice la técnica del pincel seco para destacar los relieves de las piezas mostradas en la imagen con pintura de color blanco, (Ref.19300). Construya un utillaje para curvar todas las bisagras alrededor de una punta A. De forma a todas las bisagras que le indicamos en las imágenes. Pinte las piezas N14 a N19 de color negro, (Ref.19301), y péguelas a las bisagras. Realice los orificios necesarios para insertar y fijar las portas en el casco. Si lo desea, puede colocar también las bisagras de la parte inferior de las portas. Elabore y decore las piezas que le indican las imágenes. Después, ajústelas y fíjelas al casco. Algunas de las piezas, deberá observarlas en los planos de mástiles y la plantilla PL-01 para poder elaborarlas correctamente.

**P.** Tiña las piezas para construir las cureñas con tinte sapeli, (Ref.19210). Después, péguelas piezas entre sí y añada los cáncamos que le muestran las imágenes. Aplique imprimación a los cañones y píntelos de color negro. Después, destaque sus relieves de color rojo oscuro, (Ref.19383). Pegue los cañones en sus respectivas cureñas. Realice los orificios necesarios para insertar en el casco los cañones de espiga.

**Q.** Pinte las piezas Q1 y Q2 de color negro, (Ref.19301). Después, pegue las piezas Q3 y elabore y fije las piezas Q4 a Q7. Doble y fije las piezas Q8 en las mesas de guarnición. Elabore y fije las piezas que le indican las imágenes. Deberá insertar las piezas Q10 a través de los orificios de las mesas de guarnición. File las piezas Q9 mediante las puntas A. Ajuste y fije los cañones en la cubierta y coloque los cáncamos B para inmovilizarlos.

**R.** Redondee las aristas de la pala del timón R1 y barnícela. Después, ajuste y fije las bisagras R2 mediante puntas. Deberá ajustar la medida de las puntas y de las bisagras para poder colocarlas. Realice un orificio para insertar la pala del timón en el casco. Pinte la parte superior de la pala del timón de color negro. Fije la pala del timón al casco mediante las puntas A. Realice las piezas que le indican las imágenes. Aplique barniz a todas las piezas de madera que vaya elaborando y fijando al barco.

**S-T.** Ajuste y fije las piezas S1 desde el centro del balcón hacia los extremos. Estas piezas deberá ajustarlas de longitud. Si lo desea, píntelas de color negro como el resto del casco. Elabore y vaya añadiendo las piezas que indican las imágenes utilizando como referencia la plantilla PL-01. Tiña y barnice las piezas que le indican las imágenes.

**U-V-W-X-Y-Z.** Siga las indicaciones de las imágenes siguientes para construir las cuatro barcas. Es aconsejable que identifique las piezas de cada barca y las extraiga de la plancha que las agrupa por separado para no mezclarlas. Puede teñir las cuadernas con tinte de color sapeli, (Ref.19210). Lije los cascos y fórrelos. Vaya añadiendo las piezas ya teñidas en el caso que lo necesiten. Elabore y fije las piezas que le indican las imágenes.

## **ARBOLADURA**

Para elaborar los mástiles, el primer paso a seguir será cortar las varillas según las medidas que indica la lista de piezas, o bien tomarlas directamente de los planos que están impresos a escala 1/1.

Todos los mástiles y vergas tienen cierta conicidad que se deberá realizar.

Para realizar la conicidad a los mástiles, lije las varillas, (con un lijador), aumentando el desgaste de ésta a medida que se acerca al extremo donde se quiere disminuir el diámetro. Haga rodar la varilla para que el desgaste sea igual por todo el contorno hasta conseguir llegar al diámetro que indica el plano. Para elaborar la conicidad de las vergas, realice las mismas operaciones, pero esta vez a ambos extremos de la varilla. Deberá teñir o pintar las varillas en función del modelo que esté construyendo.

Para realizar correctamente los mástiles de este modelo se deberá tener en cuenta:

- Los planos
- Las fotos de detalle de los mástiles
- Las medidas y descripción de materiales de la lista de piezas
- Las hojas “IP” de identificación de piezas
- La plantilla PL-01

Los mástiles se deberán barnizar y algunas de las piezas que los componen se deberán pintar. Véanse las fotos generales de detalle de los mástiles. Una vez montados y barnizados, deberán colocarles los aparejos, (estrobos, cuadernales, cáncamos, motones, etc.), y fijarlos al barco. Los mástiles se deben introducir hasta hacer tope en los encajes de la falsa quilla.

## **JARCIA**

Para elaborar la jarcia de este barco, siga el orden alfabético de las figuras impresas de los planos, que indican el orden de colocación: de hilos, vigotas, motones, velas, etc, destacados en color rojo. La lista de piezas le orientara sobre el tipo de materiales y medidas a utilizar.

Para simular el envejecido de las velas, se les puede dar un baño con infusión de té, sin hacerlas hervir, y dejarlas secar bien arrugadas.

Se colocaran sin planchar para que tengan cuerpo.

**A.** Glue parts A1 and A2 using a flat, stable surface and reinforce the joint using parts A3. Following the alphanumeric order insert and glue the parts as shown in the illustrations. Before gluing the frames, check that they fit correctly in their position by fitting them into the corresponding sockets of the false keel. It is important that the frames are completely perpendicular to the false keel so that the decks fit well afterwards. Use white glue, (Ref.19200).

**B.** Cut the lining strips and highlight their edges with a pencil. Start planking the deck by fitting the first strip to the pencil line, as shown in the illustration. Glue the strips close together so that the joints are not noticeable. Use contact glue (shoemaker's glue). Press the strips against the deck so that they adhere firmly. Then use a cutter to cut the surplus from the deck strips. Leave the back of the deck unfinished. Lay the decks as shown in the picture. Then sand the small decks and apply satin varnish (Ref.19209). Adjust and glue the decks as shown in the pictures.

**C and D.** Complete the main decking. Imitate the nails of the decking with a pencil. Then sand and varnish the deck. Line and varnish decks C1 and C2. Add the parts shown in the pictures to the hull. Place the hull upside down and start sanding starting from bow to stern. Roughen the edges of the frames, but without spoiling their original shape. Sanding the hull must be symmetrical; that is, the right side must be identical to the left. For the central part of the hull, use a large sanding block. Sanding must be progressive and smooth. Use a straight edge to check that you are sanding correctly. To check, slide the edge over the frames, to see how it fits the shape. Adjust and glue part D1.

**E-F-G-H.** Sand parts E1 and soak them in water for a few minutes to make them flexible. Then, use an iron to apply heat until the parts become flexible. Fit and glue parts E1 to both sides of the hull. Cut to size and add parts E2 to parts E3, note that they must be symmetrical. Then, glue the parts to the hull. Proceed in the same way to fix parts F1 and F2. These parts can already be nailed using the "A" pins. It is advisable to use a nailing tool, (Ref.19108), or, if you do not have one, a hammer. Cut to size and glue pieces F3 to the inside of the hull. Make sure you glue them firmly. Parts F3 must not be glued to the front of the hull. Offer up part F4 cut to fit into parts F2. Glue with parts F4 using white glue, (Ref.19200). Then fix your joint with "A" pins. Continue planking as shown in the pictures. If the slats are very dry and break when you bend them, soak them in water for twenty minutes. This will make them flexible. Dry them with a cloth before gluing them. The other planks of the lining must be glued to the frames and to each other, using white glue and fixed with pins. Continue gluing planks from bow to stern to line the entire hull. You will need to cut to them size and adjust them to fit the gaps. If any planks are loose, you can apply quick-drying glue. If one or more planks are lower than the others and you have some slats left, stick them on the recessed areas and then sand them down. Glue parts H2 to H11. File the heads of the pins using a flat file until they are flush with the lining. Dilute some white glue with water so you can apply it sparingly and it will creep between the plank joints. Set the hull until the adhesive dries. This operation fixes the whole hull lining, strengthening it. Then, sand the entire hull. It must be smooth and even.

**I-J.** Apply contact glue, (shoemaker's glue), to the area of the hull shown in the images. Glue the I1 lining strips in place. You must combine the I1 strips to complete the full length of the hull. Cut the strips to size according to need. Press the lining strips in place so that they adhere firmly. Remove the bits of board that cover the holes of the gunports with a cutter. Continue lining the hull upwards until you pass the bulwarks. Then, level the planking with the upper edges of the bulwarks. Proceed in the same way to line the bottom of the hull using parts I2 and I3. Sand the hull planking until it is smooth and even. Dye the inside of the bulwarks with pine-coloured dye, (Ref.19212). Adjust and bend a J1 slat and glue it so that it covers the junction of the two linings. Glue parts J3 onto parts J2. Apply primer Ref.19142 to this panel. When dry, paint the panel black, (Ref.19301). Then, highlight the relief of the pieces with white paint, (Ref.19300).

**K.** Apply primer to the wall. Then glue the aft panel. Adjust and glue parts K1 along the entire deck-bulwark seam. Then glue parts K2 and K3 using the slotted slat. Use this tool, (Ref.19158) to slot the parts. Adjust and glue parts K4 to K10.

**L.** Insert and glue parts L1 to L5. Parts L1 and L2 must be flush with parts K8 to K10 at the bottom. Add the pieces shown in the pictures. Then line parts L13 and L14 with L15 planking. Varnish the L15 planking when finished. Add the pieces shown in the illustrations.

**M.** Slot a 2 x 3 mm slat using the tool shown in the illustration. Cut to size and glue parts M1 to M5. Use a flat object to straighten the brass wire. Make and fix the parts shown in the picture.

**N-O.** Place the boat on a flat and stable surface. Use an object to attach a marker and mark the waterline 75 mm from the base. You must make this mark along the entire contour of the hull. Apply varnish (Ref.19209) to the entire underside of the hull, below the waterline. Paint the top of the hull with black paint, (Ref.19301), except the inside of the bulwarks and decks. If you do not want to paint the hull, dye and varnish the pieces using the colours that you like best. Make and fix the parts shown in the illustration. Use the dry brush technique to highlight the relief of the pieces shown in the illustration with white paint, (Ref.19300). Build a tool to bend all the hinges around a point A. Shape all the hinges shown in the images. Paint parts N14 to N19 black, (Ref.19301), and glue the hinges onto them. Make the necessary holes to insert and fix the lids to the hull. If you wish, you can also fit the hinges at the lower part of the lids. Make and decorate the pieces shown in the illustrations. Then, adjust them and fasten them to the hull. You must follow the mast drawings and template PL-01 to prepare some of the pieces them correctly.

**Q.** Stain the pieces for building the carriages with sapele dye, (Ref.19210). Then glue the pieces together and add the eyebolts shown in the illustrations. Apply primer to the gun barrels and paint them black. Then, highlight the relief in dark red, (Ref.19383). Glue the barrels into their respective carriages. Make the necessary holes to fit the carronades into the hull.

**Q.** Paint parts Q1 and Q2 black, (Ref.19301). Then, glue parts Q3 and make and fix parts Q4 to Q7. Bend and fix the Q8 parts on the chainwales. Make and fit the parts shown in the illustrations. You will need to insert the Q10 parts through the holes in the chainwales. Fit parts Q9 using the pins "A". Adjust and fit the guns on the deck and fit the eyebolts B to immobilize them.

**A.** Round the edges of the R1 rudder and varnish it. Then, adjust and secure the R2 pintles and gudgeons using pins. You must adjust the size of the pins and hinges to fit them. Make a hole to insert the rudder stock into the hull. Paint the upper part of the rudder black. Attach the rudder to the hull using pins "A". Make the parts shown in the pictures. Apply varnish to all the pieces of wood that you are making and fastening to the boat.

**S-T.** Adjust and fix parts S1 from the centre of the gallery towards the ends. You must adjust their length. If desired, paint them black like the rest of the hull. Prepare and add the parts shown in the illustration using template PL-01 as a reference. Dye and varnish the pieces shown in the pictures.

**U-V-W-X-Y-Z.** Follow the instructions in the illustrations below to build the four boats. You must identify the pieces of each boat and remove them from the sheet set by set so as not to mix them. You can dye the frames with sapele dye, (Ref.19210). Sand the hulls and line them. Add the already dyed pieces if needed. Make and fit the parts shown in the illustrations.

## **MASTS AND SPARS**

In order to make up the masts the first step is to cut the rods to size, as indicated in the parts list, or by taking measurements directly from the plans, which are printed in 1/1 scale.

All of the masts and spars have to have a certain conical shape, which they will have to be given.

In order to achieve this conical shape for the masts, sand down the rod (using a sander), increasing the amount of sanding down as you get closer to the end at which you want to decrease the diameter. Turn the rod so that you sand it down evenly on all sides, until achieving the diameter indicated in the plan.

To achieve this conical shape for the spars carry out the above operations but in this case evenly reducing the diameter at both ends of the rod.

The rods will have to be stained or painted, depending on the model that you are building.

To correctly make up the mast for this model you must take into account:

- The plans
- The close-up photos of the masts and spars
- The measurements and material descriptions of the parts list
- The "PI" parts identification sheets
- Template PL-01

The masts and spars need to be varnished, while some of the parts that make them up are meant to be painted. Examine the general and close-up photos of the masts

Once the mast and spars has been assembled and varnished fix the tackle (slings, blocks, eyebolts, clump blocks, etc.) into place on the ship. The masts will have to be fully inserted into the sockets prepared to receive them in the false keel.

## **SAILS AND RIGGING**

In order to make up the running gear for this ship follow the alphabetic order of the images printed on the plans, indicating the order for fitting the (ropes, clump blocks, blocks, sails, etc.) highlighted in red. In combination with the parts list this will serve as a guide with regard to the type of material to be used and the measurements.

A method for simulating the aging of the sails is to soak them in an infusion of tea, without boiling, and then leaving them to dry all wrinkled up. Fit them in place without ironing so that they will have a certain consistency.

**A.** Utilisez une surface plane et stable pour coller les pièces A1 et A2, et renforcez leur union à l'aide des pièces A3. En suivant l'ordre alphanumérique, insérez et collez les pièces indiquées sur les figures. Avant de coller les couples, vérifiez qu'ils s'adaptent bien à leur place et font office de « butoir » dans les emboîtements correspondants de la fausse quille. Il est important que les couples restent totalement perpendiculaires à la fausse quille afin que les ponts viennent s'emboîter correctement par la suite. Pour cette opération, utilisez comme adhésif de la colle blanche (Réf. 19200).

**B.** Découpez les bandes du bordé et accentuez ses champs à l'aide d'un crayon. Commencez à border le pont en adaptant la première plaque sur la ligne de crayon indiquée sur l'image. Collez les plaques les unes contre les autres très serrées afin que les unions ne se remarquent pas. Utilisez la colle de contact (colle de cordonnier) frottez les plaques contre le pont afin qu'elles y adhèrent fermement. Puis coupez les excédents des plaques au cutter. Ne pas terminer la partie arrière du pont. Collez les pièces comme indiqué sur l'image. Puis, poncez et appliquez du vernis satiné (Réf. 19209), sur les petits ponts. Emboîtez et collez les ponts comme le montrent les images.

**C et D.** Complétez le bordé du pont principal. Simulez le cloutage des bandes du bordé à l'aide d'un crayon. Puis, poncez et vernissez le pont. Bordez et vernissez les ponts C1 et C2. Ajoutez les pièces montrées sur les images à la coque. Placez la coque à l'envers et commencez à poncer en allant de la proue vers la poupe. Il faudra dégrossir les arêtes des couples, mais sans en altérer la forme originale. Le ponçage de la coque doit être symétrique, c'est à dire que le côté droit doit être identique au gauche. Pour la zone du milieu de la coque, utilisez une cale à poncer de plus grande surface. Le ponçage doit être progressif et doux. Vérifiez à l'aide d'un listeau que le ponçage est correct. Pour cela, faites glisser le listeau sur les couples pour voir comme il s'adapte à leur forme. Ajustez et collez les pièces D1.

**E-F-G-H.** Poncez les pièces E1 et plongez-les dans l'eau quelques minutes pour les assouplir. Ensuite, utilisez un fer à repasser pour appliquer de la chaleur et courber les pièces. Ajustez et collez les pièces E1 de part et d'autre de la coque. Découpez sur mesure et ajoutez les pièces E2 aux pièces E3, vérifiez qu'elles sont symétriques. Puis, collez les pièces sur la coque. Procédez de la même manière pour fixer les pièces F1 et F2. Ces pièces peuvent être clouées avec les pointes A. Il est conseillé d'utiliser un marteau de cloueur (Réf. 19108), ou à défaut, un marteau simple. Découpez aux dimensions et collez les pièces F3 à l'intérieur de la coque. Assurez-vous qu'elles sont fermement collées. Sur la partie avant de la coque, ne pas coller les pièces F3. Présentez la pièce F4 qui s'adapte sous les pièces F2. Collez avec de la colle blanche (Réf. 19200), les pièces F4. Puis, fixez les unions à l'aide de pointes A, poursuivez le bordé comme montré sur les images. Si les lattes sont très sèches, et qu'elles se cassent en les courbant, plongez-les dans de l'eau quelques minutes. Avec cette opération, elles gagneront en souplesse. Puis, séchez-les avec un chiffon avant de les coller. Les autres lattes du bordé doivent être collées aux couples, et entre elles, avec de la colle blanche puis fixées avec des pointes. Poursuivez en collant les lattes, de la proue à la poupe pour border la coque en entier. Vous devrez couper sur mesure et ajuster les pièces pour qu'elles s'emboîtent dans les zones creuses. Si quelque part une latte n'est pas fixée, vous pouvez appliquer de la colle à séchage rapide. Si une latte s'est enfoncée, collez-en une autre par-dessus puis, poncez. Collez les pièces H2 à H11. Limez les têtes des pointes à l'aide d'une lime plate pour égaliser sur le bordé.

Diluez un peu de colle blanche dans de l'eau afin de l'appliquer légèrement, et qu'elle pénètre entre les jointures des lattes. Mettez la coque de côté, jusqu'à ce que la colle sèche. Avec cette opération, le bordage de la coque sera unifié, ce qui lui fera gagner en consistance. Puis poncez toute la coque. Elle doit être douce et régulière.

**i-J.** Appliquez de la colle de contact (colle de cordonnier) sur la zone de la coque indiquée sur les images. Appliquez la colle et collez les lattes du bordé i1. Vous devez combiner les lattes i1 pour compléter la longueur totale de la coque. Découpez sur mesure les lattes du bordé en fonction des besoins. Appuyez en lissant sur les lattes du bordé afin qu'elles adhèrent fermement. Éliminez au fur et à mesure les portions qui recouvrent les orifices des sabords à l'aide d'un cutter. Poursuivez le bordage de la coque vers le haut, jusqu'à dépasser les pavois. Puis, égalisez le bordé avec les profils supérieurs des pavois. Procédez de la même manière pour border la partie inférieure de la coque avec les pièces i2 et i3. Poncez le bordé de la coque pour laisser une surface fine et sans inégalités. Teintez la partie intérieure des pavois avec de la teinte de couleur pin (Réf. 19212). Adaptez et collez une latte J1 et collez-la de manière à recouvrir l'union des deux bordés. Collez les pièces J3 sur les pièces J2. Appliquez au panneau obtenu, de l'enduit (Réf. 19142). Lorsqu'il est sec, peignez le panneau de couleur noire (Réf. 19301). Puis, soulignez les reliefs des pièces avec de la peinture de couleur blanche (Réf. 19300).

**K.** Appliquez de l'enduit sur la paroi. Puis collez le panneau de poupe. Adaptez et collez les pièces K1 le long de l'union du pont avec les pavois. Puis, collez les pièces K2 et K3 avec la latte rainurée. Utilisez cet outil (Réf. 19158) pour rainurer les pièces. Ajustez et collez les pièces K4 à K10.

**L.** Ajustez et collez les pièces L1 à L5. Les pièces L1 et L2 doivent rester au ras des pièces K8 à K10 dans leur partie basse. Continuez à coller les pièces indiquées sur les images. Puis, garnissez les pièces L13 et L14 avec le bordé L15. Vernissez le bordé L15 une fois terminé. Continuez à coller les pièces indiquées sur les images.

**M.** Rainure d'une latte de 2x3 mm avec l'outil indiqué sur l'image. Découpez aux dimensions et collez les pièces M1 à M5. Utilisez un objet plat pour durcir le fil en laiton. Confectionnez et collez les pièces comme indiqué sur l'image.

**N-O.** Placez le bateau sur une surface plane et stable. Utilisez un objet pour fixer un marqueur et signaler la ligne de flottaison à 75 mm de la base. Vous devez réaliser cette marque sur l'ensemble du contour de la coque. Appliquez le vernis (Réf. 19209), sur toute la partie inférieure de la coque, en dessous de la ligne marquée. Peignez la partie supérieure de la coque avec de la peinture de couleur noire (Réf. 19301), à l'exception des pavois et des ponts. Si vous ne souhaitez pas peindre la coque, teintez et vernissez les pièces avec les couleurs qui vous semblent les mieux adaptées. Confectionnez et collez les pièces comme indiqué sur l'image. Utilisez la technique du pinceau sec pour faire ressortir les reliefs des pièces montrées sur l'image avec de la peinture blanche (Réf. 19300). Élaborez des outils pour courber toutes les charnières autour d'une pointe A. Donnez une forme à toutes les charnières que nous vous indiquons sur les images. Peignez les pièces N14 à N19 de couleur noire, (Réf. 19301) et collez dessus les charnières. Réalisez les orifices nécessaires pour insérer et fixer les portes sur la coque. Si vous le souhaitez, vous pouvez également placer les charnières de la partie inférieure des portes. Construisez et décidez les pièces indiquées sur les images. Puis, adaptez-les et fixez-les sur la coque. Certaines pièces seront à observer sur les plans des mâts et la base PL-01 pour une élaboration correcte.

**P.** Teintez les pièces pour construire les affûts avec la teinte sapeli (Réf. 19210). Puis, collez les pièces entre elles et ajoutez les anneaux de levage montrés sur les images. Appliquez de l'enduit sur les canons et peignez-les en noir. Ensuite, faites ressortir leurs reliefs de couleur rouge foncé (Réf. 19383). Collez les canons sur leurs affûts respectifs. Réalisez les orifices nécessaires pour insérer dans la coque les canons flèches.

**Q.** Peignez les pièces Q1 et Q2 de couleur noire (Réf. 19301). Ensuite, collez les pièces Q3 et élaborez et fixez les pièces Q4 à Q7. Pliez et fixez les pièces Q8 sur les porte-haubans. Élaborez et décidez les pièces indiquées sur les images. Vous devrez insérer les pièces Q10 à travers les orifices des porte-haubans. Fixez les pièces Q9 à l'aide des pointes A. Adaptez et fixez les canons sur le pont et placez les anneaux de levage B pour les immobiliser.

**R.** Arrondissez les arêtes du safran de gouvernail R1 et vernissez-le. Ensuite, adaptez et fixez les charnières R2 à l'aide des pointes. Vous devez adapter la dimension des pointes et des charnières pour pouvoir les disposer. Réalisez un orifice pour insérer le safran du gouvernail sur la coque. Peignez la partie supérieure du safran du gouvernail en noir. Fixez le safran du gouvernail sur la coque à l'aide des pointes A. Réalisez les pièces indiquées sur les images. Appliquez le vernis sur toutes les pièces en bois que vous élaborez et fixez sur le bateau.

**S-T.** Adaptez et fixez les pièces S1 à partir du milieu du balcon vers les extrémités. Ces pièces devront être ajustées sur la longueur. Si vous le souhaitez, peignez-les en noir comme le reste de la coque. Élaborez et ajoutez progressivement les pièces indiquées sur les images en utilisant comme référence la base PL-01. Teintez et vernissez les pièces indiquées sur les images.

**U-V-W-X-Y-Z.** Suivez les indications des images suivantes pour construire les quatre canots. Il est conseillé d'identifier les pièces de chaque canot et de les extraire de la planche qui les regroupe et les séparer pour ne pas les mélanger. Vous pouvez teinter les couples avec la couleur sapeli (Réf. 19210). Poncez les coques et bordez-les. Ajoutez les pièces déjà teintées en cas de besoin. Élaborez et décidez les pièces indiquées sur les images.

## MÂTURE

La première chose à faire pour confectionner les mâts est de couper les baguettes aux dimensions indiquées dans la liste des pièces ou de prendre ces mesures directement des plans qui sont imprimés à l'échelle 1/1.

Tous les mâts et les vergues possèdent une certaine conicité qui doit être travaillée.

Pour réaliser la conicité des mâts, poncer les baguettes (avec une ponceuse) en augmentant le dégrossissage au fur et à mesure qu'on s'approche de l'extrémité où l'on souhaite diminuer le diamètre. Faire rouler la baguette afin que l'usure soit égale sur tout le contour jusqu'à ce qu'on obtienne le diamètre indiqué sur le plan.

Effectuer les mêmes opérations pour réaliser la conicité des vergues mais, dans ce cas, aux deux extrémités de la baguette.

Il faudra teinter ou peindre les baguettes en fonction de la maquette qui sera construite.

Pour réaliser correctement les mâts de cette maquette, il faudra tenir compte :

- Des plans
- Des photos de détail des mâts.
- Des dimensions et de la description des matériaux de la liste des pièces.
- Des feuilles « IP » d'identification des pièces.
- Le patron PL-01

Les mâts devront être vernis et certaines des pièces qui les composent devront être peintes. Voir les photos générales de détail des mâts.

Lorsque les mâts seront montés et vernis, on placera leurs appareils (estropes, mouffes, pitons, poulies, etc.) et on les attachera au bateau. Les mâts doivent être introduits de sorte qu'ils s'emboîtent à fond contre la fausse quille.

## GRÉEMENT

Pour réaliser le gréement de ce bateau, on suivra l'ordre alphabétique des figures imprimées des plans, qui indiquent l'ordre de montage (fils, caps de mouton, poulies, etc.) mis en évidence en rouge. La liste des pièces indique le type de matériaux et les dimensions à utiliser.

Pour simuler le vieillissement des voiles, on peut les faire tremper dans une infusion de thé, sans les faire bouillir, et les laisser sécher bien chiffonnées. Les voiles seront placées non repassées afin d'avoir du volume.

**A.** Su una superficie piana e stabile incollare i pezzi A1 e A2 e rinforzare la loro giunzione con i pezzi A3. Seguendo l'ordine alfanumerico, inserire e incollare i pezzi indicati nelle figure. Prima di incollare le coste, verificare che si inseriscano correttamente in posizione inserendole fino in fondo nei corrispondenti incavi della falsa chiglia. È importante che le coste siano completamente perpendicolari alla falsa chiglia in modo che i ponti si incastrino correttamente. Per questa operazione utilizzare come collante la colla bianca (Cod. 19200).

**B.** Tagliare le strisce di rivestimento ed evidenziarne i bordi con una matita. Iniziare a foderare la copertura, adattando la prima lastra alla linea di matita mostrata nell'immagine. Incollare le lastre vicini tra loro in modo che le giunzioni non siano visibili. Utilizzare come collante la colla a contatto (colla per calzalai). Strofinare le lastre contro il ponte in modo che aderiscano saldamente. Tagliare quindi le lastre in eccesso con un cutter. Lasciare il retro del ponte non rifinito. Rivestire i ponti come mostrato nell'immagine. Carteggiare e applicare la vernice satinata (rif. 19209) sui ponti piccoli. Montare e incollare i ponti come mostrato nelle immagini.

**C e D.** Completare il rivestimento del ponte principale. Simulare la chiodatura delle strisce di rivestimento con una matita. Quindi carteggiare e verniciare il ponte. Rivestire e verniciare i ponti C1 e C2. Aggiungere allo scafo le parti mostrate nelle immagini. Capovolgere lo scafo e iniziare a carteggiare partendo da prua e procedendo verso poppa. I bordi delle coste devono essere irruviditi, ma senza deformare la forma originale. Lo scafo deve essere carteggiato in modo simmetrico, cioè il lato destro deve essere uguale a quello sinistro. Per la parte centrale dello scafo, utilizzare un blocco di carteggiatura con una superficie maggiore. La carteggiatura deve essere progressiva e uniforme. Utilizzare un blocco di levigatura per verificare che la levigatura sia corretta. A tal fine, far scorrere l'asta sulle coste per vedere come si adatta alla loro forma. Montare e incollare le parti D1.

**E-F-G-H.** Carteggiare i pezzi E1 e immergerli in acqua per qualche minuto per ripristinare la loro flessibilità. Quindi utilizzare un ferro da stiro per applicare il calore e piegare le parti. Montare e incollare i pezzi E1 su entrambi i lati dello scafo. Tagliare a misura e aggiungere i pezzi E2 ai pezzi E3, tenendo presente che devono essere simmetrici. Incollare quindi i pezzi allo scafo. Procedere allo stesso modo per attaccare i pezzi F1 e F2. Queste parti possono ora essere inchiodate insieme ai pezzi A. Si consiglia di utilizzare una chiodatrice (rif. 19108) o un martello. Tagliare a misura e incollare i pezzi F3 all'interno dello scafo. Assicurarsi di incollarli saldamente. Non incollare i pezzi F3 sulla parte anteriore dello scafo. Posizionare il pezzo F4 sotto i pezzi F2. Incollare i pezzi F4 con colla bianca (rif. 19200). Continuare il rivestimento come mostrato nelle immagini. Se le aste sono troppo secche e si rompono quando vengono piegate, immergerle in acqua per qualche minuto. Questo le renderà di nuovo elastiche. In seguito, asciugarle con un panno prima di incollarle. Le altre aste del rivestimento devono essere incollate alle coste e tra loro con colla bianca e fissate con chiodini. Continuare a incollare le aste da prua a poppa per rivestire l'intero scafo. Sarà necessario tagliare a misura e adattare i pezzi ai fori. Se in qualche punto le aste sono allentate, si può applicare della colla ad asciugatura rapida. Se ci sono altre aste che si allentano, incollarne un'altra e poi carteggiarle. Incollare i pezzi da H2 a H11. Limare le teste dei chiodini con una lima piatta finché non sono a filo con il rivestimento. Diluire un po' di colla bianca con acqua in modo da poterla applicare leggermente e farla penetrare tra le giunzioni delle aste. Mettere da parte lo scafo finché la colla non si asciuga. In questo modo si uniformerà il fasciame dello scafo e lo si renderà più consistente. Quindi carteggiare l'intero scafo. Deve risultare liscio e uniforme.

**i-J.** Applicare la colla a contatto (colla per calzalai) sull'area dello scafo mostrata nelle immagini. Incollare e incollare le strisce di rivestimento i1. È necessario combinare le strisce i1 per completare la lunghezza totale dello scafo. Tagliare le strisce di rivestimento nella misura desiderata. Strofinare le strisce di rivestimento in modo che aderiscano saldamente. Tagliare con un taglierino le porzioni di lastra che coprono i fori delle feritoie. Continuare a rivestire lo scafo verso l'alto fin oltre i bastioni. Quindi far coincidere il fasciame con i profili superiori dei bastioni. Procedere allo stesso modo per allineare la parte inferiore dello scafo con le parti i2 e i3. Carteggiare il fasciame dello scafo per renderlo liscio e uniforme. Colorare l'interno dei bastioni con un colore pino (rif. 19212). Inserire e curvare un'asta J1 e incollarla in modo che copra la giunzione tra i due fasciami. Incollare i pezzi J3 sui pezzi J2. Applicare il primer (rif. 19142) sul pannello ottenuto. Quando si asciuga, dipingere il pannello di nero (rif. 19301). Evidenziare quindi i rilievi dei pezzi con vernice bianca (rif. 19300).

**K.** Applicare il primer alla parete. Incollare quindi il pannello di poppa. Montare e incollare i pezzi K1 per tutta la lunghezza della giunzione del ponte con i bastioni. Incollare quindi i pezzi K2 e K3 con l'asta scanalata. Utilizzare questo strumento (rif. 19158) per scanalare i pezzi. Montare e incollare i pezzi da K4 a K10.

**L.** Montare e incollare le parti da L1 a L5. Le parti L1 e L2 devono essere a filo con le parti da K8 a K10 sul lato inferiore. Aggiungere i pezzi come mostrato nelle immagini. Rivestire poi i pezzi L13 e L14 con il rivestimento L15. Verniciare il rivestimento L15 una volta terminato. Aggiungere i pezzi come mostrato nelle immagini.

**M.** Incidere una striscia di 2x3 mm con l'utensile mostrato nell'immagine. Tagliare a misura e incollare i pezzi da M1 a M5. Utilizzare un oggetto piatto per raddrizzare la filettatura in ottone. Realizzare e fissare i pezzi come mostrato nella figura.

**N-W.** Posizionare l'imbarcazione su una superficie piana e stabile. Utilizzare un oggetto per tenere un pennarello e segnare la linea di galleggiamento a 75 mm dalla base. Questo segno deve essere fatto lungo tutto il perimetro dello scafo. Applicare la vernice (rif. 19209) su tutta la parte inferiore dello scafo al di sotto della linea segnata. Dipingere la parte superiore dello scafo con vernice nera (rif. 19301), ad eccezione dell'interno dei bastioni e dei ponti. Se non si desidera dipingere lo scafo, è possibile colorare e verniciare le parti nei colori che si ritengono più adatti. Elaborare e fissare le parti come mostrato nella figura. Utilizzare la tecnica del pennello asciutto per evidenziare i rilievi delle parti mostrate nell'immagine con la vernice bianca (Ref.19300). Costruire uno strumento per piegare tutte le cerniere attorno a un chiodino A. Modellare tutte le cerniere come mostrato nelle immagini. Dipingere di nero i pezzi da N14 a N19 (Rif. 19301) e incollarli le cerniere. Praticare i fori necessari per inserire e fissare i portelli allo scafo. Se si desidera, è possibile montare le cerniere anche sulla parte inferiore dei portelli. Realizzare e decorare le parti come mostrato nelle immagini. Quindi montarli e fissarli allo scafo. Per alcune parti è necessario consultare i piani dell'alberatura e la sagoma PL-01 per poterle realizzare correttamente.

**P.** Per costruire gli affusti, tingere i pezzi con la tinta sapelli (rif. 19210). Incollare quindi i pezzi e aggiungere le golfare come mostrato nelle immagini. Applicare il primer sui cannoni e dipingerli di nero. Evidenziare quindi i rilievi rosso scuro (cod. 19383). Incollare i cannoni ai rispettivi affusti. Praticare i fori necessari per inserire i cannoni nello scafo.

**Q.** Dipingere di nero i pezzi Q1 e Q2 (rif. 19301). Incollare quindi i pezzi Q3 e realizzare e fissare i pezzi da Q4 a Q7. Piegare e fissare i pezzi Q8 sulle tavole di montaggio. Realizzare e fissare i pezzi come mostrato nelle immagini. È necessario inserire i pezzi Q10 attraverso i fori delle tavole di montaggio. Avvitare i pezzi Q9 utilizzando i chiodi A. Regolare e fissare i cannoni sul ponte e posizionare le golfare B per immobilizzarli.

**R.** Arrotondare i bordi della pala del timone R1 e verniciarla. Quindi montare e fissare le cerniere R2 con i chiodi. Sarà necessario regolare le dimensioni dei chiodi e delle cerniere per adattare. Praticare un foro per inserire la pala del timone nello scafo. Dipingere di nero la parte superiore della pala del timone. Fissare la pala del timone allo scafo utilizzando i chiodi A. Applicare la vernice su tutte le parti in legno man mano che si realizzano, e fissarle alla barca.

**S-T.** Regolare e fissare i pezzi S1 dal centro del balcone verso le estremità. Questi pezzi devono essere regolati in lunghezza. Se si desidera, dipingerli di nero come il resto dello scafo. Realizzare e aggiungere i pezzi indicati nelle immagini utilizzando come riferimento la sagoma PL-01. Colorare e verniciare i pezzi indicati nelle immagini.

**U-V-W-X-Y-Z.** Seguire le istruzioni riportate nelle immagini seguenti per costruire le quattro barche. È consigliabile identificare i pezzi di ogni barca e staccarli dalla lastra che li raggruppa separatamente per non confonderli. È possibile tingere le coste con tintura color sapelli (cod. 19210). Carteggiare gli scafi e rivestirli. Ove necessario, aggiungere i pezzi già verniciati. Realizzare e fissare le parti come mostrato nelle immagini.

## **ALBERATURA**

Per realizzare l'alberatura, il primo passo da seguire sarà quello di tagliare le aste secondo le misure indicate nell'elenco dei pezzi, oppure prenderle direttamente dalle planimetrie che sono stampate in scala 1/1.

Tutti gli alberi e i pennoni hanno una certa conicità che si dovrà ottenere.

Per ottenere la conicità degli alberi, occorre scartavetrare le aste (con una smerigliatrice), aumentando l'azione della stessa a misura che ci si avvicina all'estremità dove si deve diminuire il diametro. Far girare l'asta affinché la smerigliatura sia uguale su tutto il contorno, fino ad arrivare al diametro indicato nella planimetria.

Per ottenere la conicità dei pennoni, realizzare le stesse operazioni, ma in questo caso su entrambe le estremità dell'asta. Si dovranno verniciare o tingere le aste in funzione del modello che si stia realizzando.

Per realizzare gli alberi di questo modello in maniera corretta si dovranno utilizzare:

- Le planimetrie;
- Le foto dettagliate degli alberi;
- Le misure e la descrizione dei materiali nell'elenco dei pezzi;
- Le pagine "IP" con l'identificazione dei pezzi.
- La sagoma PL-01

Gli alberi devono essere smaltati ed alcuni dei pezzi che li compongono devono essere verniciati. Vedi le foto generali dettagliate degli alberi.

Una volta montati e smaltati, devono essere collocati gli attrezzi (stropi, quarnali, golfare, bozzelli, ecc.) e fissati al vascello.

Gli alberi devono essere introdotti fino in fondo negli appositi incastrati della falsa chiglia.

## **SARTIA**

Per elaborare la sartia di questo vascello occorre seguire l'ordine alfabetico delle figure stampate delle planimetrie, che indicano l'ordine di collocazione delle cime, delle bigotte, dei bozzelli, delle vele, ecc., risaltati in colore rosso. L'elenco dei pezzi serve ad orientare in merito al tipo di materiali ed alle misure da utilizzare.

Per simulare l'invecchiamento delle vele, queste possono essere bagnate con te, senza farle bollire, e poi lasciarle asciugare mantenendole ben arrugate.

Poi si collocano senza stirarle, affinché mantengano corpo.

**A.** Auf einer ebenen und stabilen Oberfläche die Teile A1 und A2 zusammenkleben und die Verbindung mit den Teilen A3 verstärken. Die auf den Abbildungen gezeigten Teile in der angegebenen Reihenfolge einsetzen und aufkleben. Vor dem Aufkleben der Spanten sicherstellen, dass die sie korrekt sitzen und mit den dazugehörigen Einkerbungen des falschen Kiels abschließen. Die Spanten müssen vollkommen senkrecht auf dem falschen Kiel stehen, damit danach die Decks gut eingesetzt werden können. Für diesen Schritt weißen Leim (Ref.19200) verwenden.

**B.** Die Plankenreihe zurechtschneiden und die Kanten mit einem Bleistift hervorheben. Mit dem Beplanken des Decks beginnen und die erste Leiste an der Bleistiftlinie ausrichten. Die Leisten eng zusammenkleben, damit keine Zwischenräume zu sehen sind. Zum Kleben Kontaktkleber verwenden (Schusterleim). Die Leisten an das Deck drücken, damit sie fest sitzen. Anschließend die überstehenden Teile mit einem Cutter abschneiden. Die Rückseite des Decks unbearbeitet lassen. Die auf der Abbildung gezeigten Decks verkleiden. Anschließend die kleinen Decks glatt schmirgeln und mit Satinlack (Ref. 19209) lackieren. Die Decks wie auf den Abbildungen gezeigt anpassen und aufkleben.

**C und D.** Die Verkleidung des Hauptdeckels abschließen. Anschließend mit dem Bleistift Markierungen anbringen, um die Plankenrinne zu simulieren. Abschließend das Deck glatt schleifen und lackieren. Die Decks C1 und C2 verkleiden und lackieren. Die auf der Abbildung gezeigten Teile an den Rumpf setzen. Den Rumpf mit der Oberseite nach unten anbringen und vom Bug in Richtung Heck glatt schleifen. Die Kanten der Spanten glätten, aber dabei nicht das ursprüngliche Profil verändern. Beim Glätten des Rumpfs darauf achten, dass beide Seiten symmetrisch zueinander sein müssen. Für den mittleren Rumpfbereich einen Sander mit großer Schleifoberfläche verwenden. Die Oberfläche nach und nach vorsichtig glätten. Mit der Leiste testen, ob eine gleichmäßige Oberfläche hergestellt wurde. Dazu die Leiste über die Spanten fahren und prüfen, wie sie sich der Form anpasst. Die Teile D1 zurechtschneiden und aufkleben.

**E-F-G-H.** E1-Teile glatt schmirgeln und kurz in Wasser einweichen, damit sie biegsamer werden. Anschließend die Teile mit einem Bügeleisen biegen. Die Teile E1 zurechtschneiden und an beiden Seiten des Rumpfs aufkleben. Die E2-Teile zurechtschneiden und an die E3-Teile setzen, dabei darauf achten, dass sie symmetrisch sitzen. Anschließend die Teile auf dem Rumpf aufkleben. Beim Verkleben der Teile F1 und F2 in gleicher Weise vorgehen. Diese Teile können jetzt mit den A-Stücken festgenagelt werden. Dazu kann man einen Nagler (Ref.19108) oder einen Hammer verwenden. Die F3-Teile zurechtschneiden und an die Innenseite des Rumpfs kleben. Darauf achten, die Teile gut festzukleben. An die Vorderseite des Rumpfs keine F3-Teile kleben. Teil F4 passend unter die Teile F2 setzen. Die F4-Teile mit weißem Leim (Ref.19200) aufkleben. Anschließend die Verbindung mit A-Stücken fixieren. Die Beplankung wie auf den Abbildungen gezeigt fortsetzen. Wenn die Leisten sehr trocken sind, ein paar Minuten in Wasser einweichen, damit sie nicht brechen. Dadurch werden die Teile biegsamer. Vor dem Aufkleben mit einem Tuch abtrocknen. Die übrigen Leisten an die Spanten und aneinander kleben und mit weißem Leim und Stiften befestigen. Die Beplankung des Rumpfs fortsetzen und Leisten von Bug nach Heck aufkleben. Die Teile für die Zwischenräume nach Maß zurechtschneiden. Lose Planken bei Bedarf mit Sekundenkleber festkleben. Wenn eine Planke zu tief eingesunken ist, eine weitere Planke darüber setzen und abschleifen. Die Teile H2 bis H11 aufkleben. Die Stiftpföpfe mit einer Feile glatt feilen, bis sie auf einer Höhe mit den Plankenreihen sind.

Etwas weißen Leim mit Wasser verdünnen, um ihn leichter auftragen zu können, so dass er sich in den Zwischenräume zwischen den Leisten verteilt. Rumpf beiseite stellen, bis der Leim getrocknet ist. Mit diesem Verfahren wird die Rumpfbeplankung verbunden und gewinnt an Stabilität. Anschließend den gesamten Rumpf glatt schmirgeln. Es muss eine glatte und gleichmäßige Oberfläche entstehen.

**i-J.** Kontaktkleber (Schusterleim) auf die Rumpfbereiche auftragen, die auf den Abbildungen zu sehen sind. Die Plankenreihe I1 mit Leim bestreichen und aufkleben. Die Leisten I1 kombinieren, um die Gesamtlänge des Rumpfs abzudecken. Die Plankenreihen passend zurechtschneiden. Die Plankenreihen fest andrücken, damit sie haften. Die Leistenteile, welche die Öffnungen an den Geschützluken bedecken, mit einem Cutter entfernen. Die Beplankung des Rumpfs nach oben über die Schanzverkleidung hinaus fortsetzen. Anschließend die Beplankung an die oberen Profile der Schanzverkleidung anpassen. Auf die gleiche Weise verfahren, um den unteren Teil des Rumpfs mit den Teilen I2 und I3 zu verkleiden. Die Rumpfbeplankung glatt schmirgeln, so dass eine gleichmäßige Oberfläche entsteht. Die Innenseite der Schanzverkleidung pinienfarben (Ref.19212) lackieren. Eine J1-Leiste zurechtschneiden und biegen und so aufkleben, dass sie den Übergang zwischen den beiden Beplankungen abdeckt. Die Teile J3 auf die Teile J2 kleben. Grundierung (Ref.19142) auf die so erhaltene Platte auftragen. Nach dem Trocknen die Platte schwarz (Ref. 19301) lackieren. Die Reliefs mit weißer Farbe (Ref.19300) hervorheben.

**K.** Grundierung auf die Wand auftragen. Anschließend die Heck-Platte aufkleben. Die K1-Teile über die gesamte Länge der Deckverbindung an die Schanzverkleidung kleben. Anschließend die Teile K2 und K3 mit der mit den Einkerbungen versehenen Leiste ankleben. Um die Einkerbungen anzubringen, dieses Werkzeug (Ref. 19158) verwenden. Die Teile K4 K bis K10 zurechtschneiden und aufkleben.

**L.** Die Teile L1 L bis L5 zurechtschneiden und aufkleben. Die Teile L1 und L2 müssen an der Unterseite mit den Teilen K8 bis K10 bündig abschließen. Die Teile, die auf den Abbildungen zu sehen sind, aufkleben. Anschließend die Teile L13 und L14 mit Leiste L15 verkleiden. Die fertige L15-Beplankung lackieren. Die auf den Abbildungen gezeigten Teile hinzufügen.

**M.** Auf einer 2x3-mm-Leiste mit dem in der Abbildung gezeigten Werkzeug Einkerbungen anbringen. Die Teile M1 bis M5 zurechtschneiden und aufkleben. Einen ebenen Gegenstand verwenden, um den Messingdraht auszurichten. Die auf der Abbildung gezeigten Teile anfertigen und befestigen.

**N-W.** Das Schiffsmodell auf eine ebene und stabile Fläche setzen. Einen Filzstift befestigen und die Wasserlinie 75 mm vom Boden entfernt einzeichnen. Die Linien um den gesamten Rumpf herum anbringen. Unterhalb der eingezeichneten Wasserlinien Lack (Ref. 19209) auf die gesamte Unterseite des Rumpfs auftragen. Die Oberseite des Rumpfs schwarz lackieren (Lack, Ref.19301), ausgenommen die Innenseiten der Schanzverkleidung und die Decks. Alternativ nur einzelne Teile in den Farben nach Wahl färben und lackieren. Die auf der Abbildung gezeigten Teile anfertigen und befestigen. Mit Trockenpinseltechnik die Reliefs der in der Abbildung gezeigten Teile mit weißer Farbe hervorheben (Ref. 19300). Ein Werkzeug anfertigen, um alle Scharniere um einen Stift A zu biegen. Alle Scharniere so formen wie auf den Abbildungen gezeigt. Die Teile N14 bis N19 schwarz (Ref.19301) lackieren und die Scharniere darauf kleben. Die Öffnungen Einsetzen und Befestigen der Luken am Rumpf anbringen. Die Scharniere können auch an der Unterseite der Luken angebracht werden. Die Teile, die auf den Abbildungen zu sehen sind, anfertigen und verzieren. Anschließend zurechtstutzen und am Rumpf befestigen. Für einige der Teile müssen beim Anfertigen die Mastpläne und die PL-01-Schablone beachtet werden.

**P.** Die Teile für den Bau der Lafetten mit Sapelly-Farbe (Ref.19210) färben. Anschließend die Teile zusammenkleben und die auf den Abbildungen gezeigten Ösen anbringen. Die Kanonen grundieren und dann schwarz lackieren. Anschließend die Reliefs dunkelrot hervorheben (Ref. 19383). Die Kanonen auf die jeweiligen Lafetten aufkleben. Die Öffnungen zum Einsetzen der Geschützrohre anbringen.

**Q.** Die Teile Q1 und Q2 schwarz (Ref. 19301) lackieren. Dann die Teile Q3 aufkleben und die Teile Q4 anfertigen und an Q7 befestigen. Die Teile Q8 zurechtbiegen und auf den Backs befestigen. Die Teile, die auf den Abbildungen zu sehen sind, anfertigen und befestigen. Die Teile Q10 durch die Löcher in den Backs führen. Die Teile Q9 mit den Stiften A durchziehen. Die Kanonen ausrichten und auf dem Deck befestigen und die Ösenstifte B einsetzen, um sie zu fixieren.

**R.** Die Kanten des Ruderblattes R1 abrunden und Ruderblatt lackieren. Anschließend die Scharniere R2 aufsetzen und mit Stiften befestigen. Stifte und Scharniere vorher passend zurechtstutzen. Ein Loch bohren, um das Ruderblatt in den Rumpf einzusetzen. Die Oberseite des Ruderblatts schwarz anmalen. Ruderblatt mit den Stiften A am Rumpf befestigen. Die Teile, die auf den Abbildungen zu sehen sind, anfertigen. Alle Holzteile nach dem Anfertigen lackieren und am Modell anbringen.

**S-T.** Die Teile S1 zurechtschneiden und von der Mitte des Balkons zu den Enden hin anbringen. Diese Teile müssen auf die passende Länge gestutzt werden. Falls gewünscht, schwarz lackieren wie den Rest des Rumpfs. Die auf den Abbildungen gezeigten Teile anfertigen und anbringen, dazu die Schablone PL-01 als Vorlage verwenden. Die Teile, die auf den Abbildungen zu sehen sind, färben und lackieren.

**U-V-W-X-Y-Z.** Die vier Rettungsboote wie auf den Abbildungen gezeigt zusammenbauen. Dazu die Einzelteile der verschiedenen Boote identifizieren und sie aus dem Blatt herauslösen, um Verwechslungen zu vermeiden. Wenn gewünscht, die Spanten in Sapelly-Farbe (Ref.19210) färben. Rumpfe glatt schmirgeln und verkleiden. Nach Bedarf bereits gefärbte Teile hinzusetzen. Die Teile, die auf den Abbildungen zu sehen sind, anfertigen und befestigen.

**BEMASTUNG**

Zur Herstellung der Masten müssen zuerst die Stäbe entsprechend der Maße zurecht geschnitten werden, die in der Teileliste angegeben sind oder die direkt anhand der Skizze abgemessen wurde. Die Skizzen sind im Maßstab 1/1 angefertigt.

Alle Masten und Rahen müssen leicht konisch verlaufen und vor dem Einbau entsprechen vorbereitet werden.

Um die Masten in Konusform zu bringen, müssen die Masten (mit einer Feile) zurecht geschliffen werden, und zwar in der Form, dass sie nach oben hin verjüngt werden. Die Stäbe dabei drehen und an allen Seiten gleichmäßig abschleifen, bis sie zu dem auf der Skizze angegebenen Durchmesser passen.

Um die Rahen in Konusform zu bringen, ebenso verfahren, allerdings hier an beiden Enden der Stangen.

Die Stäbe in Abhängigkeit von dem Modell färben oder anmalen.

Um die Masten dieses Schiffsbaumodells richtig vorzubereiten, müssen die folgenden Punkte beachtet werden:

-Die Skizzen - Detailfotos der Masten - Maße und Materialien der Teileliste - IP-Blätter zur Identifikation der Bauteile - Schablone PL-01

Die Masten müssen lackiert werden und einige der Einzelteile der Masten müssen angemalt werden. Siehe Fotos mit allgemeiner Ansicht der Masten

Nach Aufstellung und Lackierung der Masten wird die Takelung (Stroppe, Rollenblöcke, Ösen, Blockrollen etc.) an den Masten und dann am Schiff befestigt. Die Masten müssen eingesetzt werden, bis sie an die Einkerbungen des falschen Kiels stoßen.

**TAKELAGE**

Zur Takelung des Schiffsmodells die alphabetische Reihenfolge der Abbildungen befolgen, auf denen die Anbringung der Takelung (Faden, Klampböcke, Blockrollen usw.) erläutert wird. Sie sind in Rot hervorgehoben. Auf der Teileliste sehen Sie, welche Materialien zum Bau des Modells notwendig sind.

Zur künstlichen Alterung der Segel die Stoffstücke in Tee legen (nicht kochen) und trocknen lassen, bis die Stoffe faltig werden.

Die Segel ohne vorheriges Bügeln anbringen, damit sie Volumen haben.

**Lista de piezas / Parts List / Liste des pièces / Teilleiste / Elenco delle parti**

<b>N°/No./N° / Nr. No</b>	<b>Cantidad / Quantity / Quantité / Menge / Quantità</b>	<b>Medidas / Measurements / Dimensions /Maße / Misure</b>	<b>Material / Material / Matériau / Material / Materiale</b>
A1-A2	2	Precortado / Precut / Prédécoupé / Vorgeschnitten / Pretagliatto	Tablero / Plywood / Planche / Sperrholz / Tavola
A3	2	Precortado / Precut / Prédécoupé / Vorgeschnitten / Pretagliatto	Tablero / Plywood / Planche / Sperrholz / Tavola
A4-A20	17	Precortado / Precut / Prédécoupé / Vorgeschnitten / Pretagliatto	Tablero / Plywood / Planche / Sperrholz / Tavola
A21	2	Precortado / Precut / Prédécoupé / Vorgeschnitten / Pretagliatto	Tablero / Plywood / Planche / Sperrholz / Tavola
B1	230	0,6x5x80	Sicomoro / Sycamore / Sycomore / Bergahorn / Sicomoro
B2	1	Precortado / Precut / Prédécoupé / Vorgeschnitten / Pretagliatto	Tablero / Plywood / Planche / Sperrholz / Tavola
B3	1	Precortado / Precut / Prédécoupé / Vorgeschnitten / Pretagliatto	Tablero / Plywood / Planche / Sperrholz / Tavola
B4	1	Precortado / Precut / Prédécoupé / Vorgeschnitten / Pretagliatto	Tablero / Plywood / Planche / Sperrholz / Tavola
B5	1	Precortado / Precut / Prédécoupé / Vorgeschnitten / Pretagliatto	Tablero / Plywood / Planche / Sperrholz / Tavola
B6	6	0,6x5x46	Sicomoro / Sycamore / Sycomore / Bergahorn / Sicomoro
B7	6	0,6x5x50	Sicomoro / Sycamore / Sycomore / Bergahorn / Sicomoro
B8	17	0,6x5x63	Sicomoro / Sycamore / Sycomore / Bergahorn / Sicomoro
B9-B10	2	Precortado / Precut / Prédécoupé / Vorgeschnitten / Pretagliatto	Tablero / Plywood / Planche / Sperrholz / Tavola
C1	1	Precortado / Precut / Prédécoupé / Vorgeschnitten / Pretagliatto	Tablero / Plywood / Planche / Sperrholz / Tavola
C2	1	Precortado / Precut / Prédécoupé / Vorgeschnitten / Pretagliatto	Tablero / Plywood / Planche / Sperrholz / Tavola
C3	20	0,6x5x40	Sicomoro / Sycamore / Sycomore / Bergahorn / Sicomoro
C4	22	0,6x5x80	Sicomoro / Sycamore / Sycomore / Bergahorn / Sicomoro
C5-C6	4	Precortado / Precut / Prédécoupé / Vorgeschnitten / Pretagliatto	Tablero / Plywood / Planche / Sperrholz / Tavola
C7-C8	4	Precortado / Precut / Prédécoupé / Vorgeschnitten / Pretagliatto	Tablero / Plywood / Planche / Sperrholz / Tavola
C9	1	Precortado / Precut / Prédécoupé / Vorgeschnitten / Pretagliatto	Tablero / Plywood / Planche / Sperrholz / Tavola
C10-C12	6	Precortado / Precut / Prédécoupé / Vorgeschnitten / Pretagliatto	Tablero / Plywood / Planche / Sperrholz / Tavola
C13-C14	4	Precortado / Precut / Prédécoupé / Vorgeschnitten / Pretagliatto	Tablero / Plywood / Planche / Sperrholz / Tavola
C15-C16	4	Precortado / Precut / Prédécoupé / Vorgeschnitten / Pretagliatto	Tablero / Plywood / Planche / Sperrholz / Tavola
C17-C18	3	Precortado / Precut / Prédécoupé / Vorgeschnitten / Pretagliatto	Tablero / Plywood / Planche / Sperrholz / Tavola
D1	6	2x5x125	Tilo / Lime wood / Tilleul / Linde / Tiglio
E1	2	Precortado / Precut / Prédécoupé / Vorgeschnitten / Pretagliatto	Tablero / Plywood / Planche / Sperrholz / Tavola
E2	2	3x15x15	Tablero / Plywood / Planche / Sperrholz / Tavola
E3	2	Precortado / Precut / Prédécoupé / Vorgeschnitten / Pretagliatto	Tablero / Plywood / Planche / Sperrholz / Tavola
F1	2	Precortado / Precut / Prédécoupé / Vorgeschnitten / Pretagliatto	Tablero / Plywood / Planche / Sperrholz / Tavola
F2	2	Precortado / Precut / Prédécoupé / Vorgeschnitten / Pretagliatto	Tablero / Plywood / Planche / Sperrholz / Tavola
F3	30	3x15x15	Tablero / Plywood / Planche / Sperrholz / Tavola
F4	50	2x5x600	Tilo / Lime wood / Tilleul / Linde / Tiglio
H1	2	2x5x600	Tilo / Lime wood / Tilleul / Linde / Tiglio
H2-H6	10	Precortado / Precut / Prédécoupé / Vorgeschnitten / Pretagliatto	Tablero / Plywood / Planche / Sperrholz / Tavola
H7-H11	10	Precortado / Precut / Prédécoupé / Vorgeschnitten / Pretagliatto	Tablero / Plywood / Planche / Sperrholz / Tavola
i1	22	0,6x5x600	Sicomoro / Sycamore / Sycomore / Bergahorn / Sicomoro
i2	10	0,6x5x130	Sapelly / Sapelli / Sapelli / Sapelly-Holz / Sapelli
i3	50	0,6x5x600	Sapelly / Sapelli / Sapelli / Sapelly-Holz / Sapelli

**Lista de piezas / Parts List / Liste des pièces / Teileliste / Elenco delle parti**

<b>N°/No./N° / Nr. No</b>	<b>Cantidad / Quantity / Quantité / Menge / Quantità</b>	<b>Medidas / Measurements / Dimensions /Maße / Misure</b>	<b>Material / Material / Matériau / Material / Materiale</b>
J1	4	2x4x600	Nogal africano / African walnut / Noyer africain / Afrikanisches Nußbaumholz / Noce africano
J2	1	Preformado / Preformed/ Préformé / Vorgeformt / Preformato	Latón / Brass / Latón / Messing / Ottone
J3	13	Preformado / Preformed/ Préformé / Vorgeformt / Preformato	Metal / Metal / Metal / Metall / Metallo
K1	2	2x2x600	Tilo / Lime wood / Tilleul / Linde / Tiglio
K2	1	2x3x104	Sapelly / Sapelli / Sapelli / Sapelly-Holz / Sapelli
K3	2	2x3x96	Sapelly / Sapelli / Sapelli / Sapelly-Holz / Sapelli
K4	1	Precortado / Precut / Prédécoupé / Vorgeschnitten / Pretagliatto	Nogal africano / African walnut / Noyer africain / Afrikanisches Nußbaumholz / Noce africano
K5	1	Precortado / Precut / Prédécoupé / Vorgeschnitten / Pretagliatto	Nogal africano / African walnut / Noyer africain / Afrikanisches Nußbaumholz / Noce africano
K6	1	Precortado / Precut / Prédécoupé / Vorgeschnitten / Pretagliatto	Nogal africano / African walnut / Noyer africain / Afrikanisches Nußbaumholz / Noce africano
K7	1	Precortado / Precut / Prédécoupé / Vorgeschnitten / Pretagliatto	Nogal africano / African walnut / Noyer africain / Afrikanisches Nußbaumholz / Noce africano
K8-K10	6	Precortado / Precut / Prédécoupé / Vorgeschnitten / Pretagliatto	Tablero / Plywood / Planche / Sperrholz / Tavola
L1	4	2x7x290	Tilo / Lime wood / Tilleul / Linde / Tiglio
L2	4	2x7x335	Tilo / Lime wood / Tilleul / Linde / Tiglio
L3	6	2x5x9	Tilo / Lime wood / Tilleul / Linde / Tiglio
L4	4	2x2x15	Tilo / Lime wood / Tilleul / Linde / Tiglio
L5	2	Precortado / Precut / Prédécoupé / Vorgeschnitten / Pretagliatto	Tablero / Plywood / Planche / Sperrholz / Tavola
L6	1	Precortado / Precut / Prédécoupé / Vorgeschnitten / Pretagliatto	Tablero / Plywood / Planche / Sperrholz / Tavola
L7	2	Precortado / Precut / Prédécoupé / Vorgeschnitten / Pretagliatto	Tablero / Plywood / Planche / Sperrholz / Tavola
L8-L9	4	Precortado / Precut / Prédécoupé / Vorgeschnitten / Pretagliatto	Tablero / Plywood / Planche / Sperrholz / Tavola
L10	1	2x5x20	Tilo / Lime wood / Tilleul / Linde / Tiglio
L11	2	2x5x13	Tilo / Lime wood / Tilleul / Linde / Tiglio
L12	1	Precortado / Precut / Prédécoupé / Vorgeschnitten / Pretagliatto	Tablero / Plywood / Planche / Sperrholz / Tavola
L13-L14	3	Precortado / Precut / Prédécoupé / Vorgeschnitten / Pretagliatto	Tablero / Plywood / Planche / Sperrholz / Tavola
L15	30	0,6x5x75	Sicomoro / Sycamore / Sycomore / Bergahorn / Sicomoro
L16-L17	3	Precortado / Precut / Prédécoupé / Vorgeschnitten / Pretagliatto	Tablero / Plywood / Planche / Sperrholz / Tavola
L18	1	Preformado / Preformed/ Préformé / Vorgeformt / Preformato	Latón / Brass / Latón / Messing / Ottone
L19	1	Preformado / Preformed/ Préformé / Vorgeformt / Preformato	Latón / Brass / Latón / Messing / Ottone
L20	1	Preformado / Preformed/ Préformé / Vorgeformt / Preformato	Latón / Brass / Latón / Messing / Ottone
L21-L23	3	Preformado / Preformed/ Préformé / Vorgeformt / Preformato	Latón / Brass / Latón / Messing / Ottone
L24	1	2x2x128	Tilo / Lime wood / Tilleul / Linde / Tiglio
L25	1	2x2x120	Tilo / Lime wood / Tilleul / Linde / Tiglio
L26	1	Preformado / Preformed/ Préformé / Vorgeformt / Preformato	Latón / Brass / Latón / Messing / Ottone
L27	2	Preformado / Preformed/ Préformé / Vorgeformt / Preformato	Metal / Metal / Metal / Metall / Metallo
L28	6	Preformado / Preformed/ Préformé / Vorgeformt / Preformato	Metal / Metal / Metal / Metall / Metallo
L29	2	Preformado / Preformed/ Préformé / Vorgeformt / Preformato	Metal / Metal / Metal / Metall / Metallo
L30-L31	2	Preformado / Preformed/ Préformé / Vorgeformt / Preformato	Metal / Metal / Metal / Metall / Metallo
L32	6	2x5x40	Metal / Metal / Metal / Metall / Metallo
L33-L34	2	Preformado / Preformed/ Préformé / Vorgeformt / Preformato	Metal / Metal / Metal / Metall / Metallo

**Lista de piezas / Parts List / Liste des pièces / Teilleiste / Elenco delle parti**

<b>N°/No./N° / Nr. No</b>	<b>Cantidad / Quantity / Quantité / Menge / Quantità</b>	<b>Medidas / Measurements / Dimensions /Maße / Misure</b>	<b>Material / Material / Matériau / Material / Materiale</b>
L35	2	2x4x18	Nogal africano / African walnut / Noyer africain / Afrikanisches Nußbaumholz / Noce africano
M1	2	2x3x25	Sapelly / Sapelli / Sapelli / Sapelly-Holz / Sapelli
M2	2	2x3x25	Sapelly / Sapelli / Sapelli / Sapelly-Holz / Sapelli
M3	1	2x3x104	Sapelly / Sapelli / Sapelli / Sapelly-Holz / Sapelli
M4	2	2x3x40	Sapelly / Sapelli / Sapelli / Sapelly-Holz / Sapelli
M5	28	∅1x100	Latón / Brass / Latón / Messing / Ottone
M6	76	∅0,50x5	Latón / Brass / Latón / Messing / Ottone
M7	30	Preformado / Preformed/ Préformé / Vorgeformt / Preformato	Latón / Brass / Latón / Messing / Ottone
M8	1	Preformado / Preformed/ Préformé / Vorgeformt / Preformato	Metal / Metal / Metal / Metall / Metallo
M9	12	∅1x100	Latón / Brass / Latón / Messing / Ottone
M10-M11	2	Preformado / Preformed/ Préformé / Vorgeformt / Preformato	Latón / Brass / Latón / Messing / Ottone
N1	2	Preformado / Preformed/ Préformé / Vorgeformt / Preformato	Madera / Wood / Bois / Holz / Legno
N2	2	2x6x48	Sapelly / Sapelli / Sapelli / Sapelly-Holz / Sapelli
N3	2	2x6x28	Sapelly / Sapelli / Sapelli / Sapelly-Holz / Sapelli
N4	2	2x6x14	Sapelly / Sapelli / Sapelli / Sapelly-Holz / Sapelli
N5	2	2x6x24	Sapelly / Sapelli / Sapelli / Sapelly-Holz / Sapelli
N6	1	Preformado / Preformed/ Préformé / Vorgeformt / Preformato	Madera / Wood / Bois / Holz / Legno
N7	2	2x2x18	Sapelly / Sapelli / Sapelli / Sapelly-Holz / Sapelli
N8	3	2x2x28	Sapelly / Sapelli / Sapelli / Sapelly-Holz / Sapelli
N9	4	2x2x52	Sapelly / Sapelli / Sapelli / Sapelly-Holz / Sapelli
N10	5	2x2x30	Sapelly / Sapelli / Sapelli / Sapelly-Holz / Sapelli
N11	56	Preformado / Preformed/ Préformé / Vorgeformt / Preformato	Latón / Brass / Latón / Messing / Ottone
N12	4	Preformado / Preformed/ Préformé / Vorgeformt / Preformato	Latón / Brass / Latón / Messing / Ottone
N13	68	Preformado / Preformed/ Préformé / Vorgeformt / Preformato	Latón / Brass / Latón / Messing / Ottone
N14-N16	120	Precortado / Precut / Prédécoupé / Vorgeschnitten / Pretagliatto	Tablero / Plywood / Planche / Sperrholz / Tavola
N17	2	Precortado / Precut / Prédécoupé / Vorgeschnitten / Pretagliatto	Tablero / Plywood / Planche / Sperrholz / Tavola
N18-N19	4	Precortado / Precut / Prédécoupé / Vorgeschnitten / Pretagliatto	Tablero / Plywood / Planche / Sperrholz / Tavola
O1	2	5x5x30	Nogal africano / African walnut / Noyer africain / Afrikanisches Nußbaumholz / Noce africano
O2	2	Preformado / Preformed/ Préformé / Vorgeformt / Preformato	Latón / Brass / Latón / Messing / Ottone
O3	2	Preformado / Preformed/ Préformé / Vorgeformt / Preformato	Metal / Metal / Metal / Metall / Metallo
O4	8	Preformado / Preformed/ Préformé / Vorgeformt / Preformato	Metal / Metal / Metal / Metall / Metallo
O5	2	∅1x5	Latón / Brass / Latón / Messing / Ottone
O6	2	Precortado / Precut / Prédécoupé / Vorgeschnitten / Pretagliatto	Nogal africano / African walnut / Noyer africain / Afrikanisches Nußbaumholz / Noce africano
O7	4	2x20	Latón / Brass / Latón / Messing / Ottone
O8	2	4x4x20	Nogal africano / African walnut / Noyer africain / Afrikanisches Nußbaumholz / Noce africano
O9	4	Precortado / Precut / Prédécoupé / Vorgeschnitten / Pretagliatto	Tablero / Plywood / Planche / Sperrholz / Tavola
O10	8	Preformado / Preformed/ Préformé / Vorgeformt / Preformato	Latón / Brass / Latón / Messing / Ottone
O11	2	Precortado / Precut / Prédécoupé / Vorgeschnitten / Pretagliatto	Tablero / Plywood / Planche / Sperrholz / Tavola

**Lista de piezas / Parts List / Liste des pièces / Teileliste / Elenco delle parti**

<b>N°/No./N° / Nr. No</b>	<b>Cantidad / Quantity / Quantité / Menge / Quantità</b>	<b>Medidas / Measurements / Dimensions /Maße / Misure</b>	<b>Material / Material / Matériau / Material / Materiale</b>
O12	2	5x5x42	Nogal africano / African walnut / Noyer africain / Afrikanisches Nußbaumholz / Noce africano
O13	2	Preformado / Preformed/ Préformé / Vorgeformt / Preformato	Latón / Brass / Latón / Messing / Ottone
O14	4	Precortado / Precut / Prédécoupé / Vorgeschnitten / Pretagliatto	Nogal africano / African walnut / Noyer africain / Afrikanisches Nußbaumholz / Noce africano
O15	2	Precortado / Precut / Prédécoupé / Vorgeschnitten / Pretagliatto	Tablero / Plywood / Planche / Sperrholz / Tavola
O16	2	Precortado / Precut / Prédécoupé / Vorgeschnitten / Pretagliatto	Tablero / Plywood / Planche / Sperrholz / Tavola
P1-P2	48	Precortado / Precut / Prédécoupé / Vorgeschnitten / Pretagliatto	Tablero / Plywood / Planche / Sperrholz / Tavola
P3-P4	12	Precortado / Precut / Prédécoupé / Vorgeschnitten / Pretagliatto	Tablero / Plywood / Planche / Sperrholz / Tavola
P5	4	∅1,5x15	Latón / Brass / Latón / Messing / Ottone
P6	8	Preformado / Preformed/ Préformé / Vorgeformt / Preformato	Madera / Wood / Bois / Holz / Legno
P7	24	Preformado / Preformed/ Préformé / Vorgeformt / Preformato	Metal / Metal / Metal / Metall / Metallo
P8	24	Preformado / Preformed/ Préformé / Vorgeformt / Preformato	Metal / Metal / Metal / Metall / Metallo
P9	2	Preformado / Preformed/ Préformé / Vorgeformt / Preformato	Metal / Metal / Metal / Metall / Metallo
P10	28	Preformado / Preformed/ Préformé / Vorgeformt / Preformato	Metal / Metal / Metal / Metall / Metallo
P11	2	Preformado / Preformed/ Préformé / Vorgeformt / Preformato	Metal / Metal / Metal / Metall / Metallo
P12	4	Preformado / Preformed/ Préformé / Vorgeformt / Preformato	Metal / Metal / Metal / Metall / Metallo
P13	8	Preformado / Preformed/ Préformé / Vorgeformt / Preformato	Latón / Brass / Latón / Messing / Ottone
Q1	2	Precortado / Precut / Prédécoupé / Vorgeschnitten / Pretagliatto	Tablero / Plywood / Planche / Sperrholz / Tavola
Q2	2	Precortado / Precut / Prédécoupé / Vorgeschnitten / Pretagliatto	Tablero / Plywood / Planche / Sperrholz / Tavola
Q3	2	Preformado / Preformed/ Préformé / Vorgeformt / Preformato	Latón / Brass / Latón / Messing / Ottone
Q4	4	2x2x8	Sapelly / Sapelli / Sapelli / Sapelly-Holz / Sapelli
Q5	2	2x2x275	Sapelly / Sapelli / Sapelli / Sapelly-Holz / Sapelli
Q6	4	2x2x8	Sapelly / Sapelli / Sapelli / Sapelly-Holz / Sapelli
Q7	2	2x2x1055	Sapelly / Sapelli / Sapelli / Sapelly-Holz / Sapelli
Q8	34	Preformado / Preformed/ Préformé / Vorgeformt / Preformato	Latón / Brass / Latón / Messing / Ottone
Q9	54	Preformado / Preformed/ Préformé / Vorgeformt / Preformato	Latón / Brass / Latón / Messing / Ottone
Q10	54	∅0,50x50	Latón / Brass / Latón / Messing / Ottone
Q11	54	Preformado / Preformed/ Préformé / Vorgeformt / Preformato	Latón / Brass / Latón / Messing / Ottone
Q12	54	∅0,50x50	Latón / Brass / Latón / Messing / Ottone
Q13	26	∅0,50x100	Hilo marrón / Brown thread / Fil brun /braunes Baumwollfaden / Filo marrone
Q14	2	2x6x12	Sapelly / Sapelli / Sapelli / Sapelly-Holz / Sapelli
Q15	2	2x6x16	Sapelly / Sapelli / Sapelli / Sapelly-Holz / Sapelli
Q16	2	2x2x16	Nogal africano / African walnut / Noyer africain / Afrikanisches Nußbaumholz / Noce africano
Q17	2	2x2x20	Nogal africano / African walnut / Noyer africain / Afrikanisches Nußbaumholz / Noce africano
R1	1	Precortado / Precut / Prédécoupé / Vorgeschnitten / Pretagliatto	Tablero / Plywood / Planche / Sperrholz / Tavola
R2	10	Preformado / Preformed/ Préformé / Vorgeformt / Preformato	Latón / Brass / Latón / Messing / Ottone
R3	5	∅1,5x6	Latón / Brass / Latón / Messing / Ottone
R4	1	2x5x31	Nogal africano / African walnut / Noyer africain / Afrikanisches Nußbaumholz / Noce africano
R5	2	2x5x25	Nogal africano / African walnut / Noyer africain / Afrikanisches Nußbaumholz / Noce africano

**Lista de piezas / Parts List / Liste des pièces / Teileliste / Elenco delle parti**

<b>N°/No./N° / Nr. No</b>	<b>Cantidad / Quantity / Quantité / Menge / Quantità</b>	<b>Medidas / Measurements / Dimensions /Maße / Misure</b>	<b>Material / Material / Matériau / Material / Materiale</b>
R6	2	2x5x21	Nogal africano / African walnut / Noyer africain / Afrikanisches Nußbaumholz / Noce africano
R7	2	2x5x33	Nogal africano / African walnut / Noyer africain / Afrikanisches Nußbaumholz / Noce africano
R8	6	2x5x25	Nogal africano / African walnut / Noyer africain / Afrikanisches Nußbaumholz / Noce africano
R9	2	2x5x23	Nogal africano / African walnut / Noyer africain / Afrikanisches Nußbaumholz / Noce africano
R10	2	2x5x12	Nogal africano / African walnut / Noyer africain / Afrikanisches Nußbaumholz / Noce africano
R11	2	2x5x8	Nogal africano / African walnut / Noyer africain / Afrikanisches Nußbaumholz / Noce africano
R12	4	4x4x25	Nogal africano / African walnut / Noyer africain / Afrikanisches Nußbaumholz / Noce africano
R13	1	4x4x17	Nogal africano / African walnut / Noyer africain / Afrikanisches Nußbaumholz / Noce africano
R14	6	4x4x25	Nogal africano / African walnut / Noyer africain / Afrikanisches Nußbaumholz / Noce africano
R15	4	∅1x8	Latón / Brass / Latón / Messing / Ottone
R16	54	1x4x6	Tilo / Lime wood / Tilleul / Linde / Tiglio
R17-R18	12	Preformado / Preformed/ Préformé / Vorgeformt / Preformato	Madera / Wood / Bois / Holz / Legno
R19	32	Preformado / Preformed/ Préformé / Vorgeformt / Preformato	Madera / Wood / Bois / Holz / Legno
R20	4	2x3x8	Sapelly / Sapelli / Sapelli / Sapelly-Holz / Sapelli
R21	4	2x3x30	Sapelly / Sapelli / Sapelli / Sapelly-Holz / Sapelli
S1	2	Preformado / Preformed/ Préformé / Vorgeformt / Preformato	Latón / Brass / Latón / Messing / Ottone
S2	8	2x2x8	Sapelly / Sapelli / Sapelli / Sapelly-Holz / Sapelli
S3-S4	3	Preformado / Preformed/ Préformé / Vorgeformt / Preformato	Latón / Brass / Latón / Messing / Ottone
S5	78	0,6x5x10	Sicomoro / Sycamore / Sycomore / Bergahorn / Sicomoro
S6	2	Preformado / Preformed/ Préformé / Vorgeformt / Preformato	Latón / Brass / Latón / Messing / Ottone
S7	2	1x150	Latón / Brass / Latón / Messing / Ottone
S8	1	2x6x28	Sapelly / Sapelli / Sapelli / Sapelly-Holz / Sapelli
S9	1	2x6x20	Sapelly / Sapelli / Sapelli / Sapelly-Holz / Sapelli
S10	22	3x3x18	Tilo / Lime wood / Tilleul / Linde / Tiglio
S11	176	Preformado / Preformed/ Préformé / Vorgeformt / Preformato	Metal / Metal / Metal / Metall / Metallo
T1	1	Precortado / Precut / Prédécoupé / Vorgeschnitten / Pretagliatto / Pretagliatto	Tablero / Plywood / Planche / Sperrholz / Tavola
T2	1	Preformado / Preformed/ Préformé / Vorgeformt / Preformato	Latón / Brass / Latón / Messing / Ottone
T3	1	Preformado / Preformed/ Préformé / Vorgeformt / Preformato	Latón / Brass / Latón / Messing / Ottone
T4	1	Precortado / Precut / Prédécoupé / Vorgeschnitten / Pretagliatto / Pretagliatto	Tablero / Plywood / Planche / Sperrholz / Tavola
T5	1	Precortado / Precut / Prédécoupé / Vorgeschnitten / Pretagliatto / Pretagliatto	Tablero / Plywood / Planche / Sperrholz / Tavola
T6	2	2x2x20	Tilo / Lime wood / Tilleul / Linde / Tiglio
T7	2	2x2x11	Tilo / Lime wood / Tilleul / Linde / Tiglio
T8	2	Precortado / Precut / Prédécoupé / Vorgeschnitten / Pretagliatto / Pretagliatto	Tablero / Plywood / Planche / Sperrholz / Tavola
T9	4	2x2x16	Tilo / Lime wood / Tilleul / Linde / Tiglio
T10	4	2x2x11	Tilo / Lime wood / Tilleul / Linde / Tiglio
T11	6	2x2x15	Tilo / Lime wood / Tilleul / Linde / Tiglio
T12	4	2x2x20	Tilo / Lime wood / Tilleul / Linde / Tiglio
T13	2	2x2x24	Tilo / Lime wood / Tilleul / Linde / Tiglio

**Lista de piezas / Parts List / Liste des pièces / Teileliste / Elenco delle parti**

<b>N°/No./N° / Nr. No</b>	<b>Cantidad / Quantity / Quantité / Menge / Quantità</b>	<b>Medidas / Measurements / Dimensions /Maße / Misure</b>	<b>Material / Material / Matériau / Material / Materiale</b>
T14	2	2x2x7	Tilo / Lime wood / Tilleul / Linde / Tiglio
T15	2	2x2x13	Tilo / Lime wood / Tilleul / Linde / Tiglio
T16	3	Preformado / Preformed/ Préformé / Vorgeformt / Preformato	Latón / Brass / Latón / Messing / Ottone
T17	2	Preformado / Preformed/ Préformé / Vorgeformt / Preformato	Latón / Brass / Latón / Messing / Ottone
T18	8	Preformado / Preformed/ Préformé / Vorgeformt / Preformato	Latón / Brass / Latón / Messing / Ottone
T19	2	Preformado / Preformed/ Préformé / Vorgeformt / Preformato	Latón / Brass / Latón / Messing / Ottone
T20	4	Preformado / Preformed/ Préformé / Vorgeformt / Preformato	Latón / Brass / Latón / Messing / Ottone
T21	2	Preformado / Preformed/ Préformé / Vorgeformt / Preformato	Latón / Brass / Latón / Messing / Ottone
T22	14	Preformado / Preformed/ Préformé / Vorgeformt / Preformato	Latón / Brass / Latón / Messing / Ottone
T23	2	Preformado / Preformed/ Préformé / Vorgeformt / Preformato	Latón / Brass / Latón / Messing / Ottone
T24	15	Preformado / Preformed/ Préformé / Vorgeformt / Preformato	Latón / Brass / Latón / Messing / Ottone
T25	1	Preformado / Preformed/ Préformé / Vorgeformt / Preformato	Metal / Metal / Metal / Metall / Metallo
T26	2	Preformado / Preformed/ Préformé / Vorgeformt / Preformato	Metal / Metal / Metal / Metall / Metallo
T27	2	Preformado / Preformed/ Préformé / Vorgeformt / Preformato	Metal / Metal / Metal / Metall / Metallo
T28	1	Preformado / Preformed/ Préformé / Vorgeformt / Preformato	Metal / Metal / Metal / Metall / Metallo
T29	1	Preformado / Preformed/ Préformé / Vorgeformt / Preformato	Metal / Metal / Metal / Metall / Metallo
T30	16	Preformado / Preformed/ Préformé / Vorgeformt / Preformato	Latón / Brass / Latón / Messing / Ottone
T31	64	ø1x10	Latón / Brass / Latón / Messing / Ottone
T32	4	Preformado / Preformed/ Préformé / Vorgeformt / Preformato	Metal / Metal / Metal / Metall / Metallo
T33	4	Preformado / Preformed/ Préformé / Vorgeformt / Preformato	Latón / Brass / Latón / Messing / Ottone
T34	4	Preformado / Preformed/ Préformé / Vorgeformt / Preformato	Metal / Metal / Metal / Metall / Metallo
T35	4	Preformado / Preformed/ Préformé / Vorgeformt / Preformato	Latón / Brass / Latón / Messing / Ottone
T36-T37	2	Precortado / Precut / Prédécoupé / Vorgeschnitten / Pretagliatto / Pretagliatto	Tablero / Plywood / Planche / Sperrholz / Tavola
T38	2	2x2x79	Tilo / Lime wood / Tilleul / Linde / Tiglio
T39	1	ø1,5x18	Latón / Brass / Latón / Messing / Ottone
T40	1	Preformado / Preformed/ Préformé / Vorgeformt / Preformato	Madera / Wood / Bois / Holz / Legno
T41	2	Preformado / Preformed/ Préformé / Vorgeformt / Preformato	Metal / Metal / Metal / Metall / Metallo
T42	2	Preformado / Preformed/ Préformé / Vorgeformt / Preformato	Metal / Metal / Metal / Metall / Metallo
T43	4	Preformado / Preformed/ Préformé / Vorgeformt / Preformato	Metal / Metal / Metal / Metall / Metallo
T44	1	Preformado / Preformed/ Préformé / Vorgeformt / Preformato	Metal / Metal / Metal / Metall / Metallo
T45	1	Preformado / Preformed/ Préformé / Vorgeformt / Preformato	Metal / Metal / Metal / Metall / Metallo
T46	2	ø0,15x100	Hilo crudo / Raw thread / Fil brut / Rohes Baumwollfaden / Filo crudo
T47	2	Preformado / Preformed/ Préformé / Vorgeformt / Preformato	Latón / Brass / Latón / Messing / Ottone
T48	2	Precortado / Precut / Prédécoupé / Vorgeschnitten / Pretagliatto / Pretagliatto	Nogal africano / African walnut / Noyer africain / Afrikanisches Nußbaumholz / Noce africano
T49	2	ø3x5	Tilo / Lime wood / Tilleul / Linde / Tiglio
T50	2	ø1x20	Latón / Brass / Latón / Messing / Ottone
T51	8	ø0,15x50	Hilo crudo / Raw thread / Fil brut / Rohes Baumwollfaden / Filo crudo
T52	1	Preformado / Preformed/ Préformé / Vorgeformt / Preformato	Metal / Metal / Metal / Metall / Metallo

**Lista de piezas / Parts List / Liste des pièces / Teileliste / Elenco delle parti**

<b>N°/No./N° / Nr. No</b>	<b>Cantidad / Quantity / Quantité / Menge / Quantità</b>	<b>Medidas / Measurements / Dimensions /Maße / Misure</b>	<b>Material / Material / Matériau / Material / Materiale</b>
T53-T54	2	Precortado / Precut / Prédécoupé / Vorgeschnitten / Pretagliatto / Pretagliatto	Tablero / Plywood / Planche / Sperrholz / Tavola
T55	2	Precortado / Precut / Prédécoupé / Vorgeschnitten / Pretagliatto / Pretagliatto	Tablero / Plywood / Planche / Sperrholz / Tavola
U1	1	Precortado / Precut / Prédécoupé / Vorgeschnitten / Pretagliatto / Pretagliatto	Tablero / Plywood / Planche / Sperrholz / Tavola
U2-U14	14	Precortado / Precut / Prédécoupé / Vorgeschnitten / Pretagliatto / Pretagliatto	Tablero / Plywood / Planche / Sperrholz / Tavola
U15	1	Precortado / Precut / Prédécoupé / Vorgeschnitten / Pretagliatto / Pretagliatto	Tablero / Plywood / Planche / Sperrholz / Tavola
U2-U29	14	Precortado / Precut / Prédécoupé / Vorgeschnitten / Pretagliatto / Pretagliatto	Tablero / Plywood / Planche / Sperrholz / Tavola
U30	1	Precortado / Precut / Prédécoupé / Vorgeschnitten / Pretagliatto / Pretagliatto	Tablero / Plywood / Planche / Sperrholz / Tavola
U31-U42	12	Precortado / Precut / Prédécoupé / Vorgeschnitten / Pretagliatto / Pretagliatto	Tablero / Plywood / Planche / Sperrholz / Tavola
U43	1	Precortado / Precut / Prédécoupé / Vorgeschnitten / Pretagliatto / Pretagliatto	Tablero / Plywood / Planche / Sperrholz / Tavola
U44-U54	11	Precortado / Precut / Prédécoupé / Vorgeschnitten / Pretagliatto / Pretagliatto	Tablero / Plywood / Planche / Sperrholz / Tavola
U55-58	4	Precortado / Precut / Prédécoupé / Vorgeschnitten / Pretagliatto / Pretagliatto	Tablero / Plywood / Planche / Sperrholz / Tavola
U59-U66	16	Precortado / Precut / Prédécoupé / Vorgeschnitten / Pretagliatto / Pretagliatto	Tablero / Plywood / Planche / Sperrholz / Tavola
V1	44	1x3x170	Tilo / Lime wood / Tilleul / Linde / Tiglio
V2	14	2x2x100	Caoba / Mahogany / Acajou / Mahagoni / Mogano
V3	1	Precortado / Precut / Prédécoupé / Vorgeschnitten / Pretagliatto / Pretagliatto	Tablero / Plywood / Planche / Sperrholz / Tavola
V4	1	Precortado / Precut / Prédécoupé / Vorgeschnitten / Pretagliatto / Pretagliatto	Tablero / Plywood / Planche / Sperrholz / Tavola
V5	1	Precortado / Precut / Prédécoupé / Vorgeschnitten / Pretagliatto / Pretagliatto	Tablero / Plywood / Planche / Sperrholz / Tavola
V6	1	Precortado / Precut / Prédécoupé / Vorgeschnitten / Pretagliatto / Pretagliatto	Tablero / Plywood / Planche / Sperrholz / Tavola
V7	1	2x2x115	Sapelly / Sapelli / Sapelli / Sapelly-Holz / Sapelli
V8-V9	2	Precortado / Precut / Prédécoupé / Vorgeschnitten / Pretagliatto / Pretagliatto	Tablero / Plywood / Planche / Sperrholz / Tavola
V10	1	Precortado / Precut / Prédécoupé / Vorgeschnitten / Pretagliatto / Pretagliatto	Tablero / Plywood / Planche / Sperrholz / Tavola
V11-V12	2	Precortado / Precut / Prédécoupé / Vorgeschnitten / Pretagliatto / Pretagliatto	Tablero / Plywood / Planche / Sperrholz / Tavola
V13	1	Precortado / Precut / Prédécoupé / Vorgeschnitten / Pretagliatto / Pretagliatto	Tablero / Plywood / Planche / Sperrholz / Tavola
V14	1	Precortado / Precut / Prédécoupé / Vorgeschnitten / Pretagliatto / Pretagliatto	Tablero / Plywood / Planche / Sperrholz / Tavola
V15	1	Precortado / Precut / Prédécoupé / Vorgeschnitten / Pretagliatto / Pretagliatto	Tablero / Plywood / Planche / Sperrholz / Tavola
V16	1	Precortado / Precut / Prédécoupé / Vorgeschnitten / Pretagliatto / Pretagliatto	Tablero / Plywood / Planche / Sperrholz / Tavola
W1	8	1x3x33	Tilo / Lime wood / Tilleul / Linde / Tiglio
W2	2	Precortado / Precut / Prédécoupé / Vorgeschnitten / Pretagliatto / Pretagliatto	Tablero / Plywood / Planche / Sperrholz / Tavola
W3	1	Precortado / Precut / Prédécoupé / Vorgeschnitten / Pretagliatto / Pretagliatto	Tablero / Plywood / Planche / Sperrholz / Tavola
W4	1	Precortado / Precut / Prédécoupé / Vorgeschnitten / Pretagliatto / Pretagliatto	Tablero / Plywood / Planche / Sperrholz / Tavola
W5	8	1x3x29	Tilo / Lime wood / Tilleul / Linde / Tiglio
W6	7	1x3x24	Tilo / Lime wood / Tilleul / Linde / Tiglio
W7	1	Precortado / Precut / Prédécoupé / Vorgeschnitten / Pretagliatto / Pretagliatto	Tablero / Plywood / Planche / Sperrholz / Tavola
W8	1	Precortado / Precut / Prédécoupé / Vorgeschnitten / Pretagliatto / Pretagliatto	Tablero / Plywood / Planche / Sperrholz / Tavola
W9	2	ø0,50x28	Latón / Brass / Latón / Messing / Ottone
W10	9	1x3x15	Tilo / Lime wood / Tilleul / Linde / Tiglio
X1	8	2x4x60	Nogal africano / African walnut / Noyer africain / Afrikanisches Nußbaumholz / Noce africano
X2	16	2x4x28	Nogal africano / African walnut / Noyer africain / Afrikanisches Nußbaumholz / Noce africano

**Lista de piezas / Parts List / Liste des pièces / Teileliste / Elenco delle parti**

<b>Nº/No./Nº / Nr. No</b>	<b>Cantidad / Quantity / Quantité / Menge / Quantità</b>	<b>Medidas / Measurements / Dimensions /Maße / Misure</b>	<b>Material / Material / Matériau / Material / Materiale</b>
X3	24	ø0,50x30	Latón / Brass / Latón / Messing / Ottone
X4	4	ø6	Latón / Brass / Latón / Messing / Ottone
X5	4	1,5x220	Latón / Brass / Latón / Messing / Ottone
X6	2	Preformado / Preformed/ Préformé / Vorgeformt / Preformato	Latón / Brass / Latón / Messing / Ottone
X7	1	Precortado / Precut / Prédécoupé / Vorgeschnitten / Pretagliatto / Pretagliatto	Nogal africano / African walnut / Noyer africain / Afrikanisches Nußbaumholz / Noce africano
Y1	1	ø0,15x250	Hilo crudo / Raw thread / Fil brut / Rohes Baumwollfaden / Filo crudo
Y2	2	2x2x50	Tilo / Lime wood / Tilleul / Linde / Tiglio
Y3	2	ø0,15x250	Hilo crudo / Raw thread / Fil brut / Rohes Baumwollfaden / Filo crudo
Y4	30	10x200	Tela / Cloth / Étoffe / Stoff / Tela
Y5	1	5x5x20	Nogal africano / African walnut / Noyer africain / Afrikanisches Nußbaumholz / Noce africano
Y6	2	2x2x9	Tilo / Lime wood / Tilleul / Linde / Tiglio
Y7	5	ø1x4	Latón / Brass / Latón / Messing / Ottone
Y8	1	ø1x6	Latón / Brass / Latón / Messing / Ottone
Y9	1	ø1x3	Latón / Brass / Latón / Messing / Ottone
Y10	1	1x5	Latón / Brass / Latón / Messing / Ottone
Y11	1	ø5x10	Tilo / Lime wood / Tilleul / Linde / Tiglio
Z1	2	ø0,15x150	Hilo crudo / Raw thread / Fil brut / Rohes Baumwollfaden / Filo crudo
Z2	4	ø0,15x300	Hilo crudo / Raw thread / Fil brut / Rohes Baumwollfaden / Filo crudo
Z3	2	Preformado / Preformed/ Préformé / Vorgeformt / Preformato	Latón / Brass / Latón / Messing / Ottone
Z4	2	Preformado / Preformed/ Préformé / Vorgeformt / Preformato	Latón / Brass / Latón / Messing / Ottone
Z5	2	ø0,15x350	Hilo crudo / Raw thread / Fil brut / Rohes Baumwollfaden / Filo crudo
MT1	1	ø10x229	Tilo / Lime wood / Tilleul / Linde / Tiglio
MT2	8	2x33	Latón / Brass / Laiton / Messing / Ottone
MT3	1	3x5x171	Tilo / Lime wood / Tilleul / Linde / Tiglio
MT4	38	2x40	Latón / Brass / Laiton / Messing / Ottone
MT5	1	Precortado / Precut / Prédécoupé / Vorgeschnitten/ Pretagliatto	Nogal africano / African walnut / Noyer africain / Afrikanisches Nußbaumholz / Noce africano
MT6	2	ø1x70	Latón / Brass / Laiton / Messing / Ottone
MT7	1	ø5x199	Tilo / Lime wood / Tilleul / Linde / Tiglio
MT8	1	Preformado / Preformed/ Préformé / Vorgeformt / Preformato	Metal / Metal / Metal / Metall / Metallo
MT9	1	Precortado / Precut / Prédécoupé / Vorgeschnitten/ Pretagliatto	Nogal africano / African walnut / Noyer africain / Afrikanisches Nußbaumholz / Noce africano
MT10	2	3x3x16	Tilo / Lime wood / Tilleul / Linde / Tiglio
MT11	1	ø3x75	Tilo / Lime wood / Tilleul / Linde / Tiglio
MT12	2	ø6	Latón / Brass / Laiton / Messing / Ottone
MT13	1	ø4x183	Tilo / Lime wood / Tilleul / Linde / Tiglio
MT14	1	2x30	Latón / Brass / Laiton / Messing / Ottone
MT15	1	ø1x71	Latón / Brass / Laiton / Messing / Ottone
MT16	2	ø0,50x150	Hilo marrón / Brown thread / Fil brun /braunes Baumwollfaden / Filo marrone
MT17	2	2x5x5	Tilo / Lime wood / Tilleul / Linde / Tiglio

**Lista de piezas / Parts List / Liste des pièces / Teileliste / Elenco delle parti**

<b>Nº/No./Nº / Nr. No</b>	<b>Cantidad / Quantity / Quantité / Menge / Quantità</b>	<b>Medidas / Measurements / Dimensions /Maße / Misure</b>	<b>Material / Material / Matériau / Material / Materiale</b>
MT18	2	ø0,50x250	Hilo marrón / Brown thread / Fil brun /braunes Baumwollfaden / Filo marrone
MT19	1	ø5x262	Tilo / Lime wood / Tilleul / Linde / Tiglio
MT20	16	ø0,50x80	Hilo marrón / Brown thread / Fil brun /braunes Baumwollfaden / Filo marrone
MT21	14	ø0,50x100	Hilo marrón / Brown thread / Fil brun /braunes Baumwollfaden / Filo marrone
MT22	1	ø10x298	Tilo / Lime wood / Tilleul / Linde / Tiglio
MT23	2	3x40	Latón / Brass / Laiton / Messing / Ottone
MT24	2	1x5x159	Tilo / Lime wood / Tilleul / Linde / Tiglio
MT25	12	2x40	Latón / Brass / Laiton / Messing / Ottone
MT26	4	1x5x127	Tilo / Lime wood / Tilleul / Linde / Tiglio
MT27	4	Precortado / Precut / Prédécoupé / Vorgeschnitten/ Pretagliato	Tablero / Plywood / Planche / Sperrholz / Tavola
MT28	4	Precortado / Precut / Prédécoupé / Vorgeschnitten/ Pretagliato	Tablero / Plywood / Planche / Sperrholz / Tavola
MT29	2	3x5x76	Tilo / Lime wood / Tilleul / Linde / Tiglio
MT30	4	2x5x20	Tilo / Lime wood / Tilleul / Linde / Tiglio
MT31	1	Precortado / Precut / Prédécoupé / Vorgeschnitten/ Pretagliato	Tablero / Plywood / Planche / Sperrholz / Tavola
MT32	36	0,6x5x80	Sicomoro / Sycamore / Sycomore / Bergahorn / Sicomoro
MT33	1	Precortado / Precut / Prédécoupé / Vorgeschnitten/ Pretagliato	Tablero / Plywood / Planche / Sperrholz / Tavola
MT34	2	3x5x9	Tilo / Lime wood / Tilleul / Linde / Tiglio
MT35	44	ø1x24	Latón / Brass / Laiton / Messing / Ottone
MT36	8	Precortado / Precut / Prédécoupé / Vorgeschnitten/ Pretagliato	Tablero / Plywood / Planche / Sperrholz / Tavola
MT37	8	Preformado / Preformed/ Préformé / Vorgeformt / Preformato	Metal / Metal / Metal / Metall / Metallo
MT38	4	2x2x5	Tilo / Lime wood / Tilleul / Linde / Tiglio
MT39	9	ø0,80x125	Hilo marrón / Brown thread / Fil brun /braunes Baumwollfaden / Filo marrone
MT40	12	ø1x10	Latón / Brass / Latón / Messing / Ottone
MT41	1	Precortado / Precut / Prédécoupé / Vorgeschnitten/ Pretagliato	Tablero / Plywood / Planche / Sperrholz / Tavola
MT42	2	Precortado / Precut / Prédécoupé / Vorgeschnitten/ Pretagliato	Nogal africano / African walnut / Noyer africain / Afrikanisches Nußbaumholz / Noce africano
MT43	4	ø1x90	Latón / Brass / Latón / Messing / Ottone
MT44	1	ø8x212	Tilo / Lime wood / Tilleul / Linde / Tiglio
MT45	1	3x3x60	Tilo / Lime wood / Tilleul / Linde / Tiglio
MT46	2	Precortado / Precut / Prédécoupé / Vorgeschnitten/ Pretagliato	Nogal africano / African walnut / Noyer africain / Afrikanisches Nußbaumholz / Noce africano
MT47	2	ø1x52	Latón / Brass / Latón / Messing / Ottone
MT48	4	Precortado / Precut / Prédécoupé / Vorgeschnitten/ Pretagliato	Tablero / Plywood / Planche / Sperrholz / Tavola
MT49	4	Precortado / Precut / Prédécoupé / Vorgeschnitten/ Pretagliato	Tablero / Plywood / Planche / Sperrholz / Tavola
MT50	1	2x2x60	Tilo / Lime wood / Tilleul / Linde / Tiglio
MT51	1	2x2x55	Tilo / Lime wood / Tilleul / Linde / Tiglio
MT52	4	Precortado / Precut / Prédécoupé / Vorgeschnitten/ Pretagliato	Tablero / Plywood / Planche / Sperrholz / Tavola
MT53	3	2x2x20	Tilo / Lime wood / Tilleul / Linde / Tiglio
MT54	3	2x2x5	Tilo / Lime wood / Tilleul / Linde / Tiglio
MT55	1	ø4x193	Tilo / Lime wood / Tilleul / Linde / Tiglio

**Lista de piezas / Parts List / Liste des pièces / Teileliste / Elenco delle parti**

<b>N°/No./N° / Nr. No</b>	<b>Cantidad / Quantity / Quantité / Menge / Quantità</b>	<b>Medidas / Measurements / Dimensions /Maße / Misure</b>	<b>Material / Material / Matériau / Material / Materiale</b>
MT56	2	Precortado / Precut / Prédécoupé / Vorgeschnitten/ Pretagliato	Tablero / Plywood / Planche / Sperrholz / Tavola
MT57	8	1x3x10	Tilo / Lime wood / Tilleul / Linde / Tiglio
MT58	6	ø0,50x15	Latón / Brass / Latón / Messing / Ottone
MT59	3	Preformado / Preformed/ Préformé / Vorgeformt / Preformato	Latón / Brass / Latón / Messing / Ottone
MT60	1	ø6x317	Tilo / Lime wood / Tilleul / Linde / Tiglio
MT61	32	1x3x42	Tilo / Lime wood / Tilleul / Linde / Tiglio
MT62	36	ø0,50x100	Latón / Brass / Latón / Messing / Ottone
MT63	8	Preformado / Preformed/ Préformé / Vorgeformt / Preformato	Metal / Metal / Metal / Metall / Metallo
MT64	8	Preformado / Preformed/ Préformé / Vorgeformt / Preformato	Metal / Metal / Metal / Metall / Metallo
MT65	4	Preformado / Preformed/ Préformé / Vorgeformt / Preformato	Metal / Metal / Metal / Metall / Metallo
MT66	6	ø0,50x100	Hilo marrón / Brown thread / Fil brun /braunes Baumwollfaden / Filo marrone
MT67	2	ø0,80x225	Hilo marrón / Brown thread / Fil brun /braunes Baumwollfaden / Filo marrone
MT68	2	ø3x154	Tilo / Lime wood / Tilleul / Linde / Tiglio
MT69	1	ø5x270	Tilo / Lime wood / Tilleul / Linde / Tiglio
MT70	16	2x15	Latón / Brass / Latón / Messing / Ottone
MT71	2	ø0,80x210	Hilo marrón / Brown thread / Fil brun /braunes Baumwollfaden / Filo marrone
MT72	2	ø3x133	Tilo / Lime wood / Tilleul / Linde / Tiglio
MT73	1	ø4x154	Tilo / Lime wood / Tilleul / Linde / Tiglio
MT74	4	ø0,50x175	Hilo marrón / Brown thread / Fil brun /braunes Baumwollfaden / Filo marrone
MT75	1	ø4x114	Tilo / Lime wood / Tilleul / Linde / Tiglio
MT76	2	3x3x60	Tilo / Lime wood / Tilleul / Linde / Tiglio
MT77	2	ø3x170	Tilo / Lime wood / Tilleul / Linde / Tiglio
MT78	1	ø4x110	Tilo / Lime wood / Tilleul / Linde / Tiglio
MT79	2	ø1x10	Latón / Brass / Latón / Messing / Ottone
MT80	1	ø10x320	Tilo / Lime wood / Tilleul / Linde / Tiglio
MT81	2	3x5x80	Tilo / Lime wood / Tilleul / Linde / Tiglio
MT82	1	Precortado / Precut / Prédécoupé / Vorgeschnitten/ Pretagliato	Tablero / Plywood / Planche / Sperrholz / Tavola
MT83	1	Precortado / Precut / Prédécoupé / Vorgeschnitten/ Pretagliato	Tablero / Plywood / Planche / Sperrholz / Tavola
MT84	1	Precortado / Precut / Prédécoupé / Vorgeschnitten/ Pretagliato	Tablero / Plywood / Planche / Sperrholz / Tavola
MT85	1	ø8x229	Tilo / Lime wood / Tilleul / Linde / Tiglio
MT86	1	3x3x60	Tilo / Lime wood / Tilleul / Linde / Tiglio
MT87	1	2x2x63	Tilo / Lime wood / Tilleul / Linde / Tiglio
MT88	1	2x2x56	Tilo / Lime wood / Tilleul / Linde / Tiglio
MT89	1	ø4x215	Tilo / Lime wood / Tilleul / Linde / Tiglio
MT90	1	ø8x351	Tilo / Lime wood / Tilleul / Linde / Tiglio
MT91	2	ø0,80x225	Hilo marrón / Brown thread / Fil brun /braunes Baumwollfaden / Filo marrone
MT92	2	ø3x170	Tilo / Lime wood / Tilleul / Linde / Tiglio
MT93	1	ø6x290	Tilo / Lime wood / Tilleul / Linde / Tiglio











**Lista de piezas / Parts List / Liste des pièces / Teileliste / Elenco delle parti**

<b>N°/No./N° / Nr. No</b>	<b>Cantidad / Quantity / Quantité / Menge / Quantità</b>	<b>Medidas / Measurements / Dimensions /Maße / Misure</b>	<b>Material / Material / Matériau / Material / Materiale</b>
MT94	2	ø0,80x200	Hilo marrón / Brown thread / Fil brun /braunes Baumwollfaden / Filo marrone
MT95	2	ø3x137	Tilo / Lime wood / Tilleul / Linde / Tiglio
MT96	1	ø4x174	Tilo / Lime wood / Tilleul / Linde / Tiglio
MT97	2	ø0,50x185	Hilo marrón / Brown thread / Fil brun /braunes Baumwollfaden / Filo marrone
MT98	1	ø4x141	Tilo / Lime wood / Tilleul / Linde / Tiglio
MT99	1	ø4x80	Tilo / Lime wood / Tilleul / Linde / Tiglio
MT100	1	ø8x257	Tilo / Lime wood / Tilleul / Linde / Tiglio
MT101	1	1x5x149	Tilo / Lime wood / Tilleul / Linde / Tiglio
MT102	1	Preformado / Preformed/ Préformé / Vorgeformt / Preformato	Metal / Metal / Metal / Metall / Metallo
MT103	1	3x70	Latón / Brass / Latón / Messing / Ottone
MT104	2	Precortado / Precut / Prédécoupé / Vorgeschnitten/ Pretagliato	Tablero / Plywood / Planche / Sperrholz / Tavola
MT105	2	Precortado / Precut / Prédécoupé / Vorgeschnitten/ Pretagliato	Tablero / Plywood / Planche / Sperrholz / Tavola
MT106	2	3x5x55	Tilo / Lime wood / Tilleul / Linde / Tiglio
MT107	2	2x5x15	Tilo / Lime wood / Tilleul / Linde / Tiglio
MT108	1	Precortado / Precut / Prédécoupé / Vorgeschnitten/ Pretagliato	Tablero / Plywood / Planche / Sperrholz / Tavola
MT109	1	Precortado / Precut / Prédécoupé / Vorgeschnitten/ Pretagliato	Tablero / Plywood / Planche / Sperrholz / Tavola
MT110	1	2x5x6	Tilo / Lime wood / Tilleul / Linde / Tiglio
MT111	22	ø1x20	Latón / Brass / Latón / Messing / Ottone
MT112	1	Precortado / Precut / Prédécoupé / Vorgeschnitten/ Pretagliato	Tablero / Plywood / Planche / Sperrholz / Tavola
MT113	1	Precortado / Precut / Prédécoupé / Vorgeschnitten/ Pretagliato	Nogal africano / African walnut / Noyer africain / Afrikanisches Nußbaumholz / Noce africano
MT114	1	2x60	Latón / Brass / Latón / Messing / Ottone
MT115	1	ø6x163	Tilo / Lime wood / Tilleul / Linde / Tiglio
MT116	1	3x3x45	Tilo / Lime wood / Tilleul / Linde / Tiglio
MT117	2	Precortado / Precut / Prédécoupé / Vorgeschnitten/ Pretagliato	Tablero / Plywood / Planche / Sperrholz / Tavola
MT118	2	Precortado / Precut / Prédécoupé / Vorgeschnitten/ Pretagliato	Tablero / Plywood / Planche / Sperrholz / Tavola
MT119	1	2x2x43	Tilo / Lime wood / Tilleul / Linde / Tiglio
MT120	1	2x2x39	Tilo / Lime wood / Tilleul / Linde / Tiglio
MT121	2	Precortado / Precut / Prédécoupé / Vorgeschnitten/ Pretagliato	Tablero / Plywood / Planche / Sperrholz / Tavola
MT122	1	Precortado / Precut / Prédécoupé / Vorgeschnitten/ Pretagliato	Nogal africano / African walnut / Noyer africain / Afrikanisches Nußbaumholz / Noce africano
MT123	1	2x40	Latón / Brass / Latón / Messing / Ottone
MT124	1	ø4x157	Tilo / Lime wood / Tilleul / Linde / Tiglio
MT125	1	2x2x43	Tilo / Lime wood / Tilleul / Linde / Tiglio
MT126	4	1x3x10	Tilo / Lime wood / Tilleul / Linde / Tiglio
MT127	1	ø5x268	Tilo / Lime wood / Tilleul / Linde / Tiglio
MT128	6	1x3x38	Tilo / Lime wood / Tilleul / Linde / Tiglio
MT129	3	ø0,50x100	Hilo marrón / Brown thread / Fil brun /braunes Baumwollfaden / Filo marrone
MT130	1	ø4x184	Tilo / Lime wood / Tilleul / Linde / Tiglio
MT131	5	1x3x23	Tilo / Lime wood / Tilleul / Linde / Tiglio

**Lista de piezas / Parts List / Liste des pièces / Teilleiste / Elenco delle parti**

<b>N°/No./N° / Nr. No</b>	<b>Cantidad / Quantity / Quantité / Menge / Quantità</b>	<b>Medidas / Measurements / Dimensions /Maße / Misura</b>	<b>Material / Material / Matériau / Material / Materiale</b>
MT132	6	2x10	Latón / Brass / Latón / Messing / Ottone
MT133	2	ø0,80x185	Hilo marrón / Brown thread / Fil brun /braunes Baumwollfaden / Filo marrone
MT134	1	ø4x122	Tilo / Lime wood / Tilleul / Linde / Tiglio
MT135	4	ø0,50x175	Hilo marrón / Brown thread / Fil brun /braunes Baumwollfaden / Filo marrone
MT136	1	ø4x88	Tilo / Lime wood / Tilleul / Linde / Tiglio
MT137	1	ø5x214	Tilo / Lime wood / Tilleul / Linde / Tiglio
MT138	1	ø1x10	Latón / Brass / Latón / Messing / Ottone
MT139	1	ø4x190	Tilo / Lime wood / Tilleul / Linde / Tiglio
MT140	1	Precortado / Precut / Prédécoupé / Vorgeschnitten/ Pretagliato	Tablero / Plywood / Planche / Sperrholz / Tavola
MT141	2	2x12	Latón / Brass / Latón / Messing / Ottone
MT142	4	2x2x5	Tilo / Lime wood / Tilleul / Linde / Tiglio
MT143	2	5x5x30	Nogal africano / African walnut / Noyer africain / Afrikanisches Nußbaumholz / Noce africano
MT144	2	2x22	Latón / Brass / Latón / Messing / Ottone

*Lista de piezas / Parts List / Liste des pièces / Teileliste / Elenco delle parti*

<i>Nº/No./ Nº / Nr. / No</i>	<i>Descripción / Description /Description / Beschreibung / Descrizione</i>	<i>Cantidad / Quantity / Quantité / Menge / Quantità</i>	<i>Medidas / Measurements / Dimensions /Maße / Misure</i>	<i>Material / Material / Matériau / Material / Materiale</i>
A		1200	10	Metal / Metal / Metal / Metall / Metallo
B		380	15	Latón / Brass / Latón / Messing / Ottone
C		335	ø0,15x150	Hilo crudo / Raw thread / Fil brut / Rohes Baumwollfaden / Filo crudo
D		213	4	Madera / Wood / Bois / Holz / Legno
E		95	4	Madera / Wood / Bois / Holz / Legno
F		56	4	Madera / Wood / Bois / Holz / Legno
H		32	ø3	Latón / Brass / Latón / Messing / Ottone
J		148	10	Madera / Wood / Bois / Holz / Legno
K		5	3	Cristal / Glass / Verre / Glas / Vetro
O		100	ø4	Latón / Brass / Latón / Messing / Ottone



Accede a vídeos tutoriales fotografiando los códigos QR.  
Access tutorial videos photographing QR codes.  
Accédez aux didacticiels vidéo photographiant les codes QR.  
Greifen Sie auf Video-Tutorials zu, die QR-Code fotografieren.  
Accedi ai video tutorial fotografando i codici QR.  
Доступ к видеоурокам фотографирования QR-кодов.

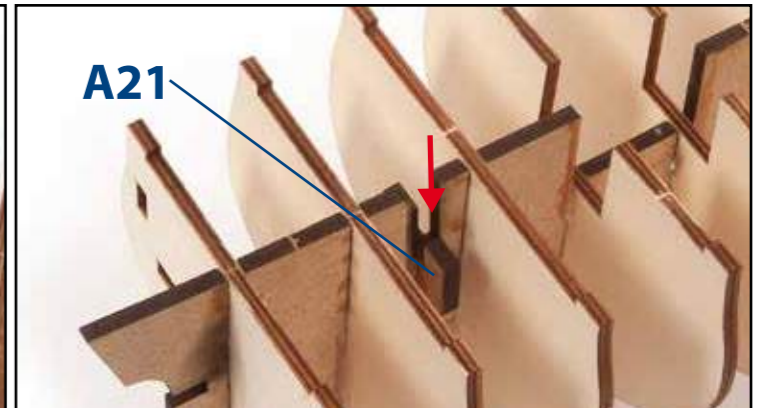
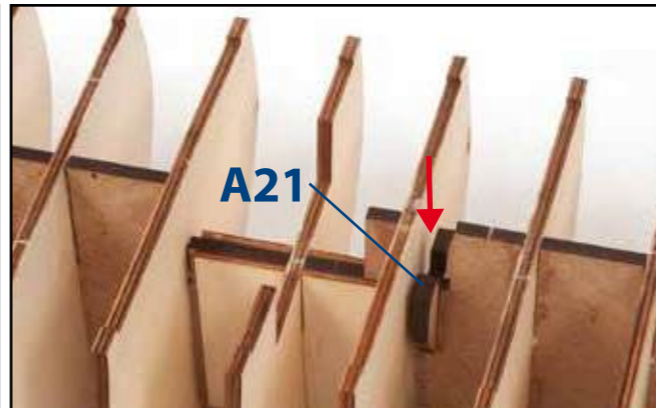
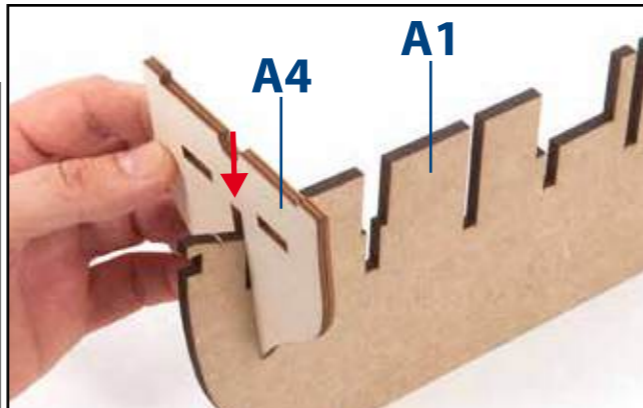
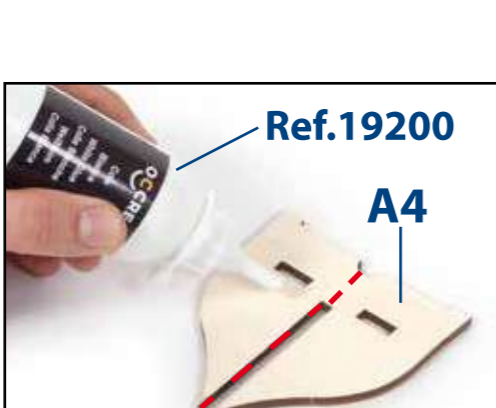
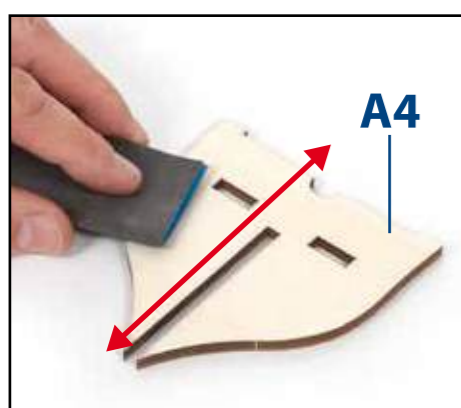
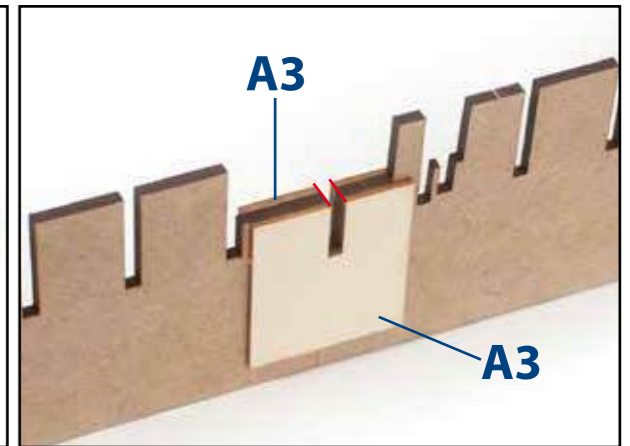
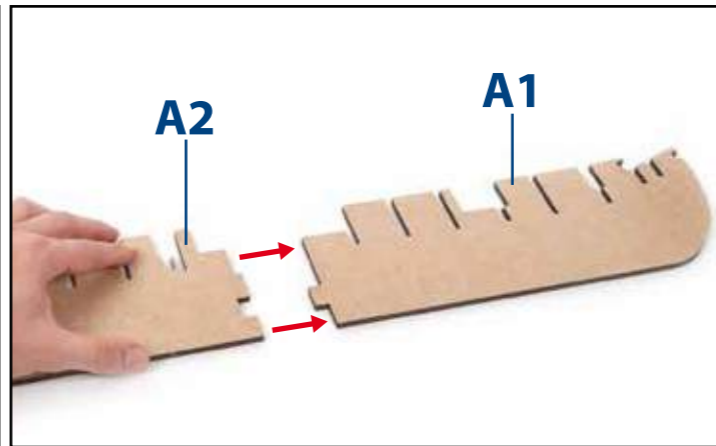
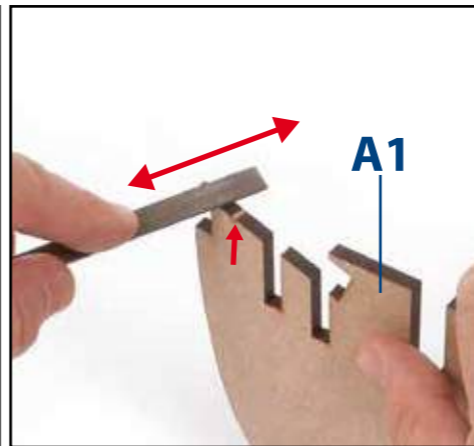
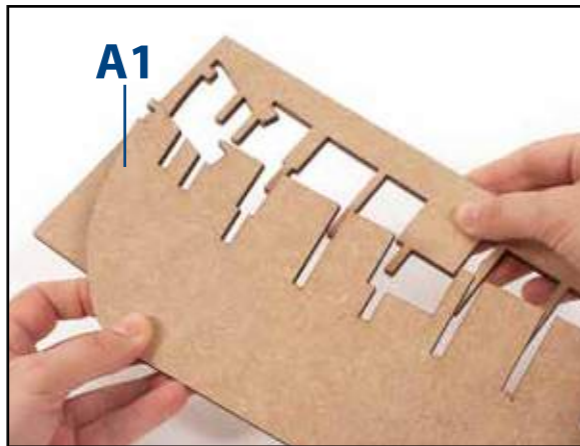
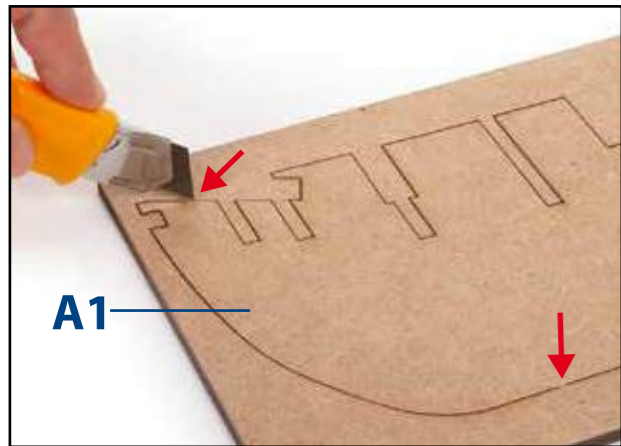
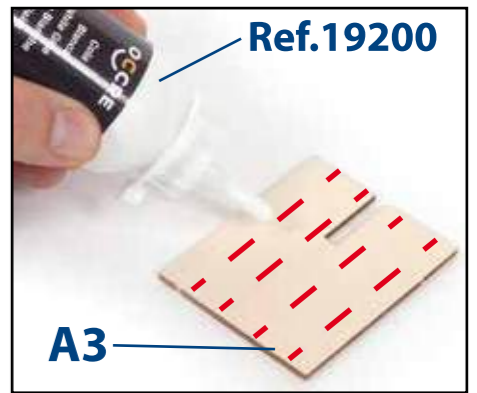
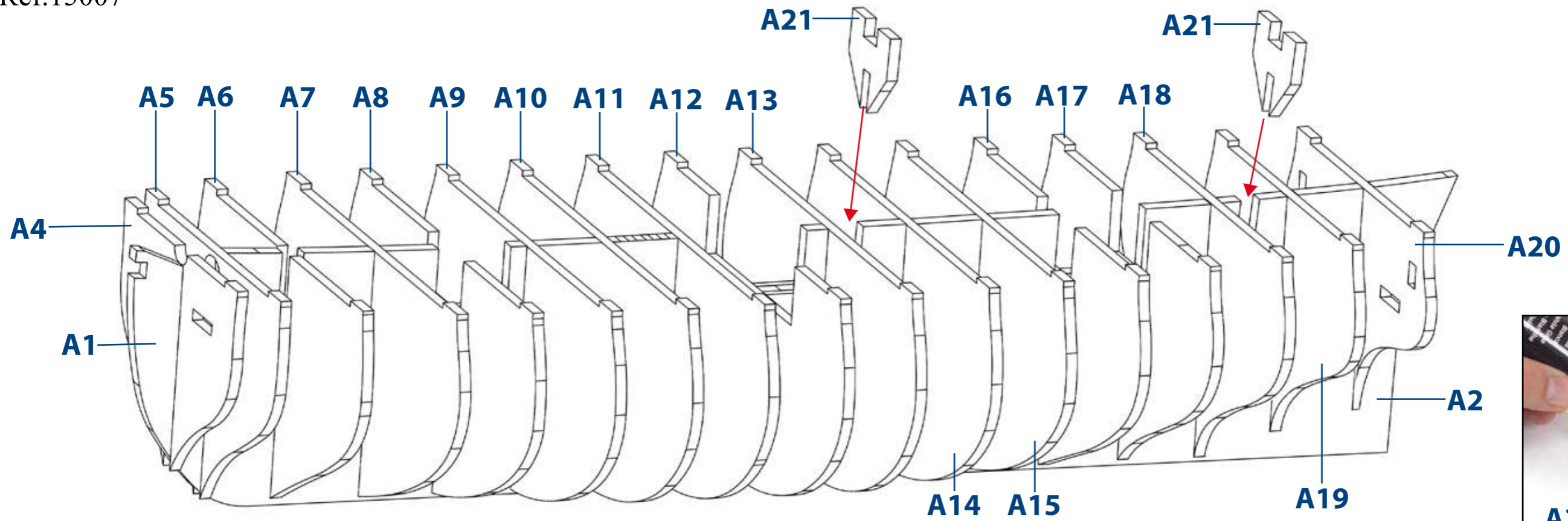
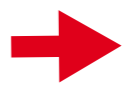

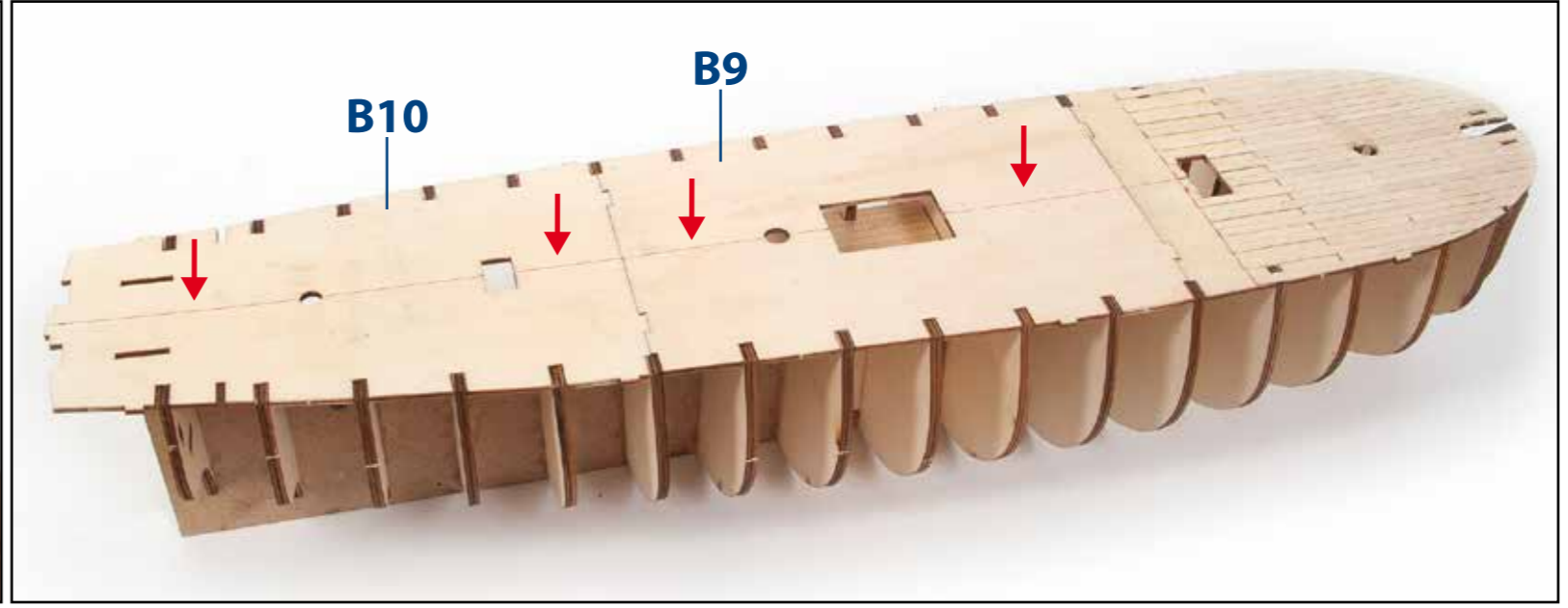
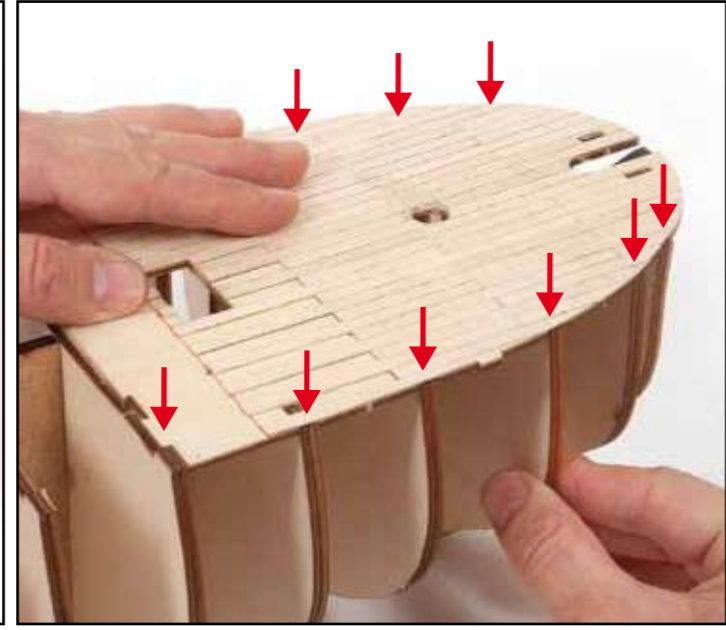
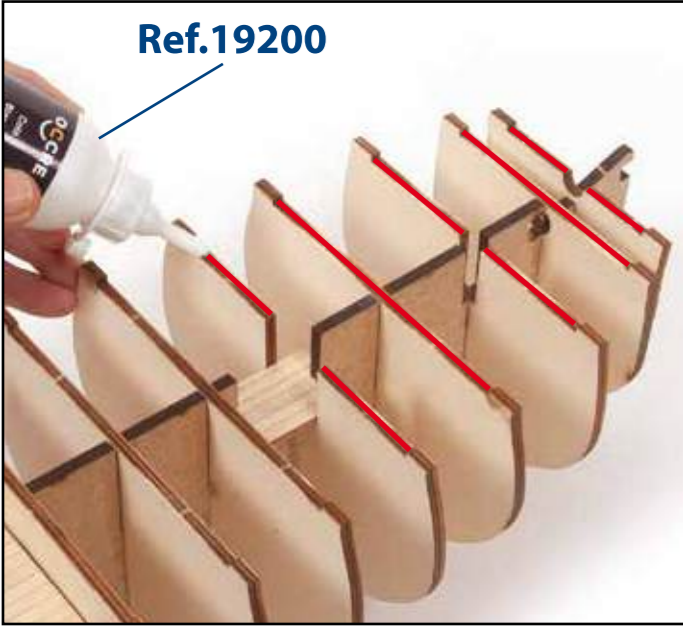
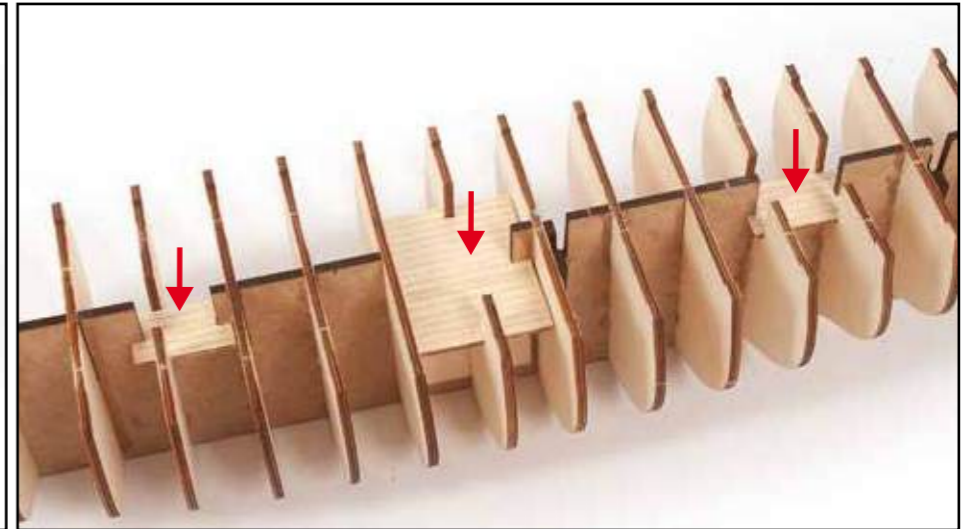
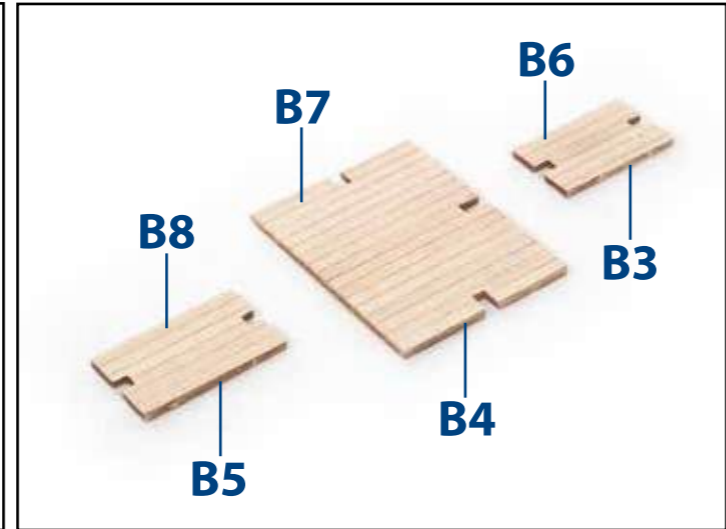
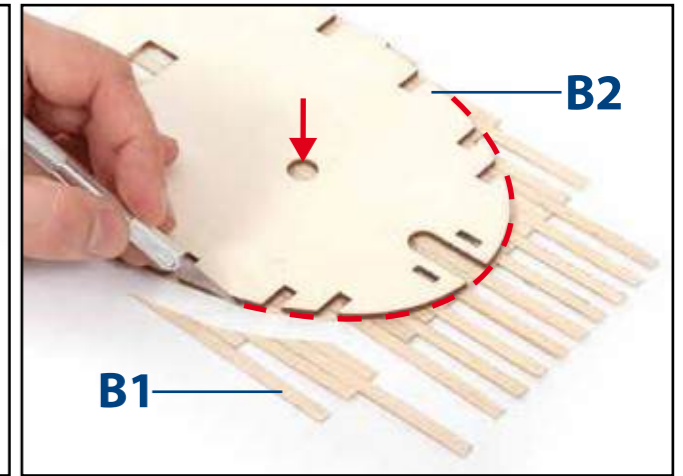
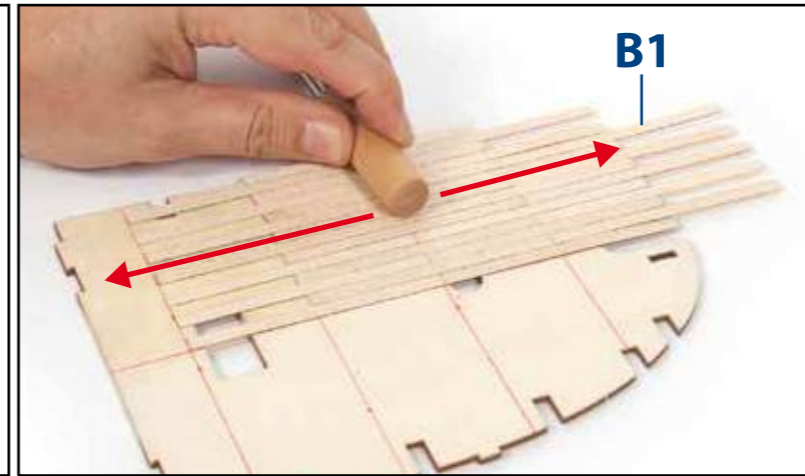
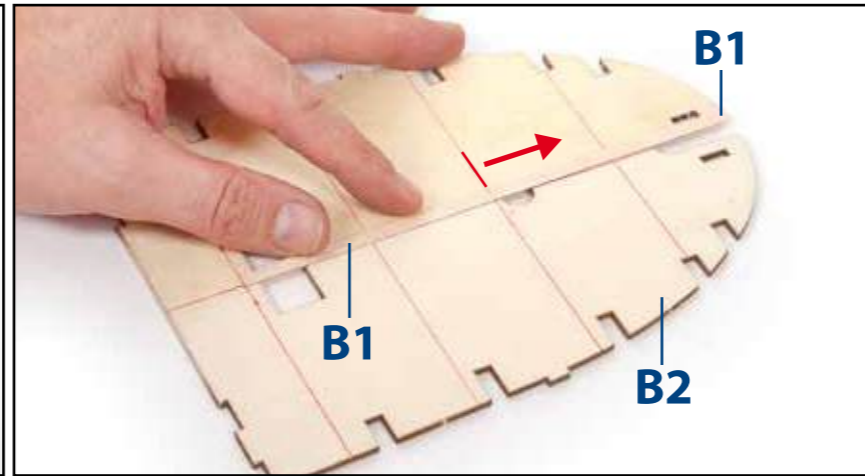
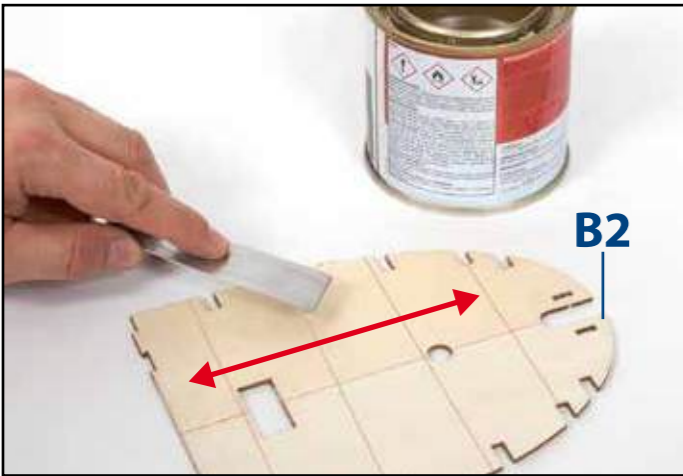
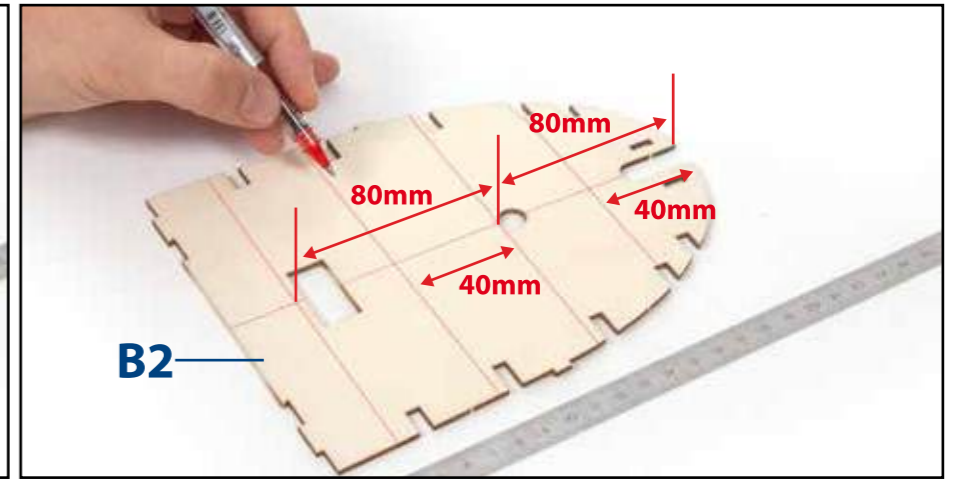
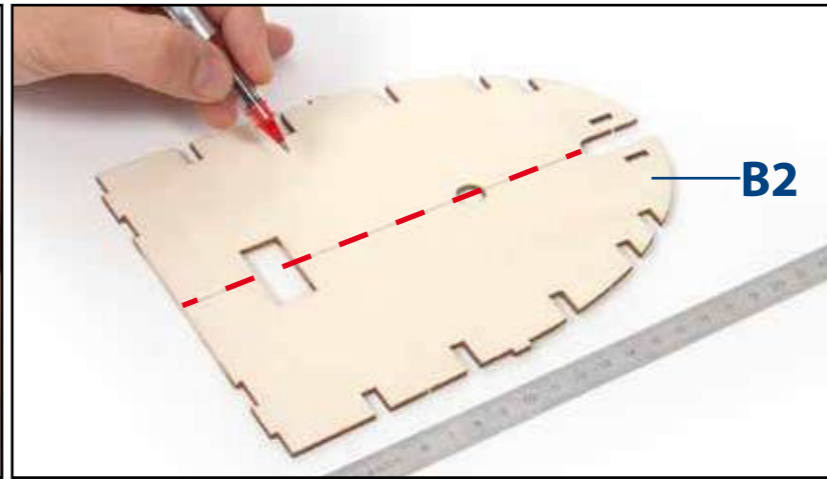
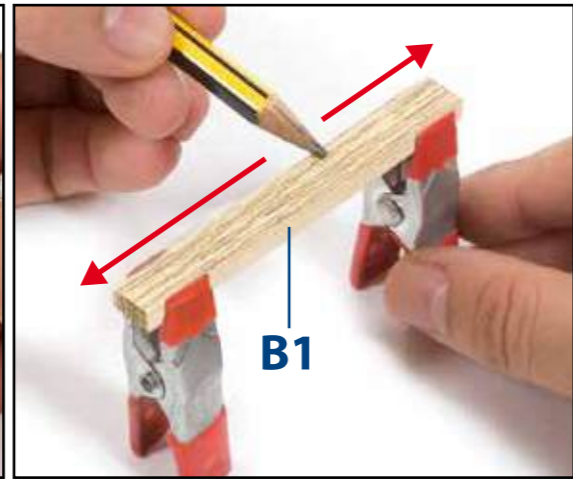
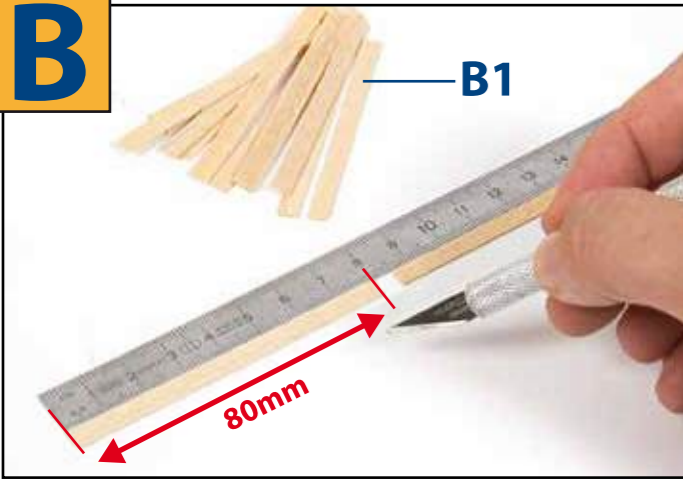
**B**

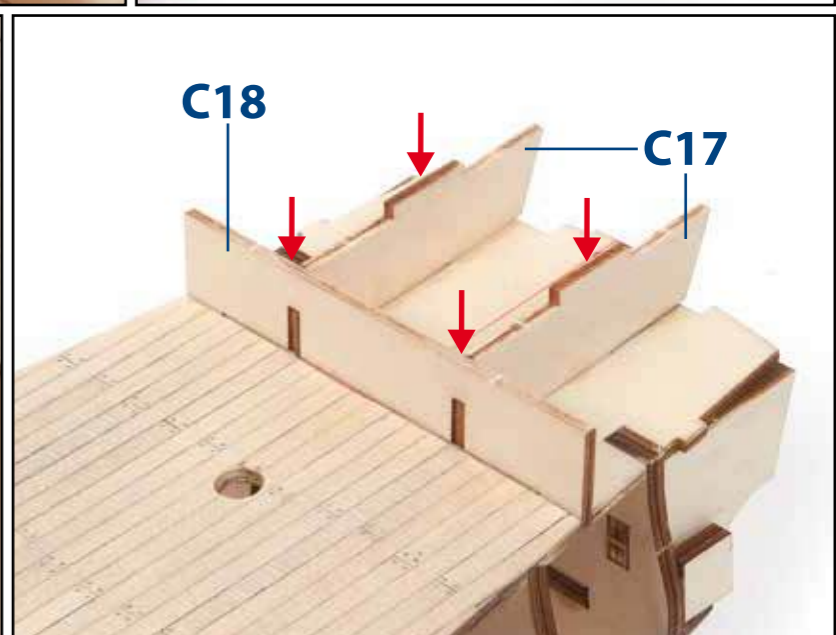
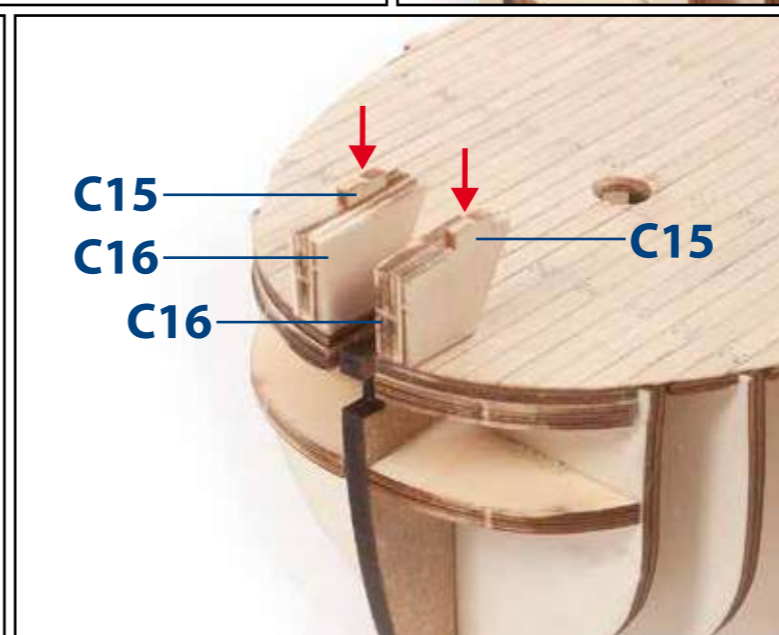
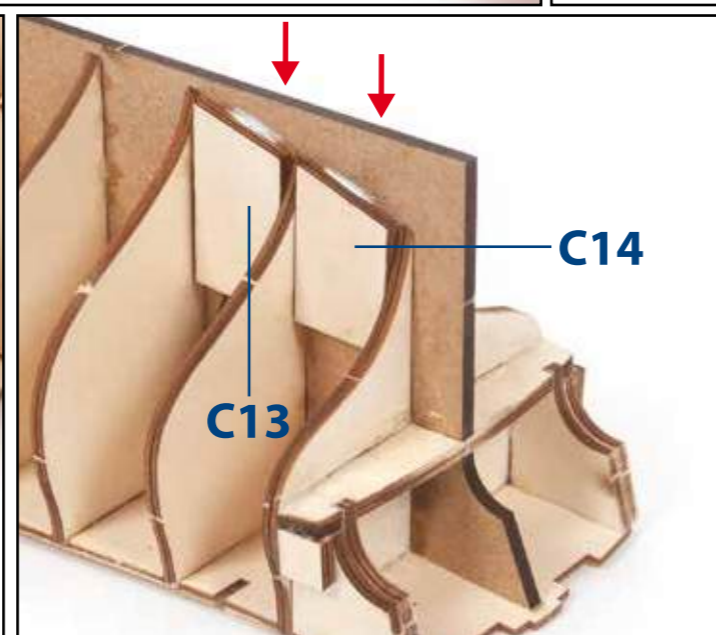
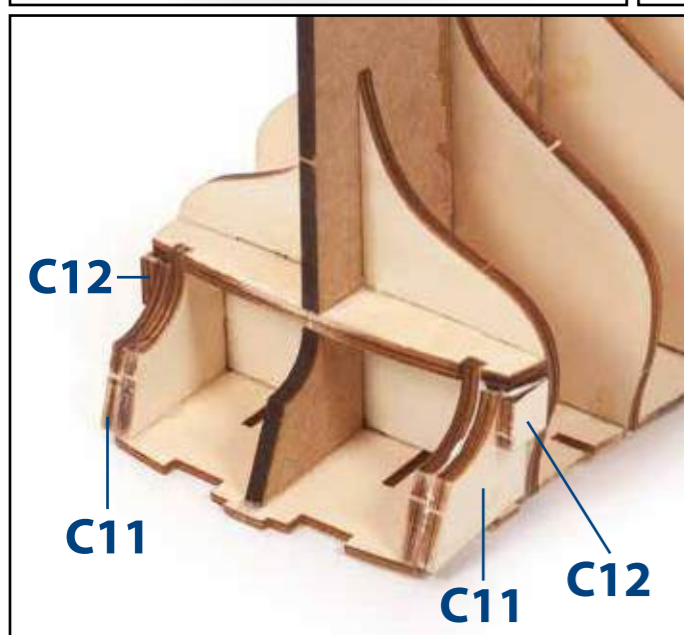
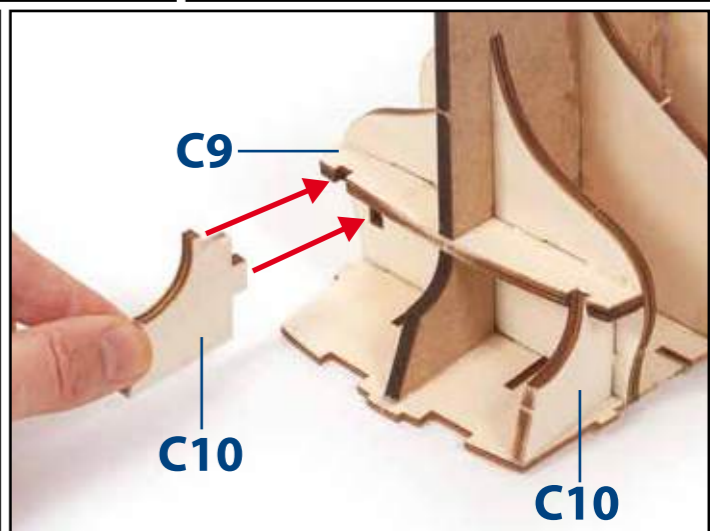
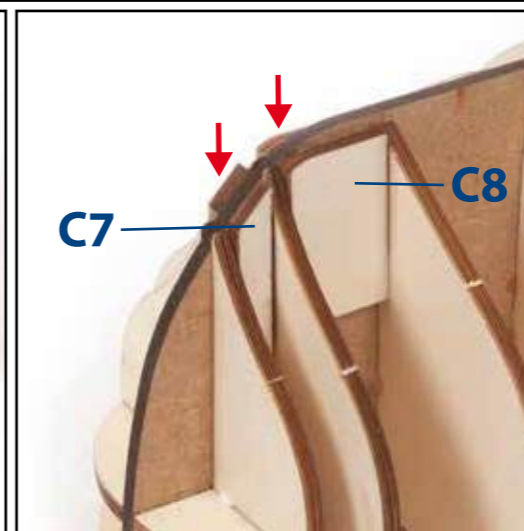
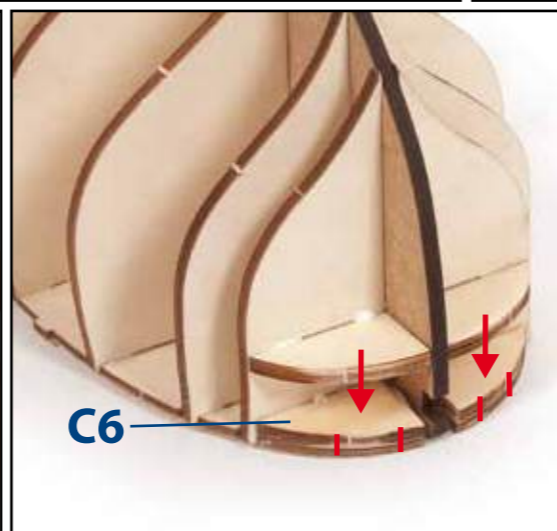
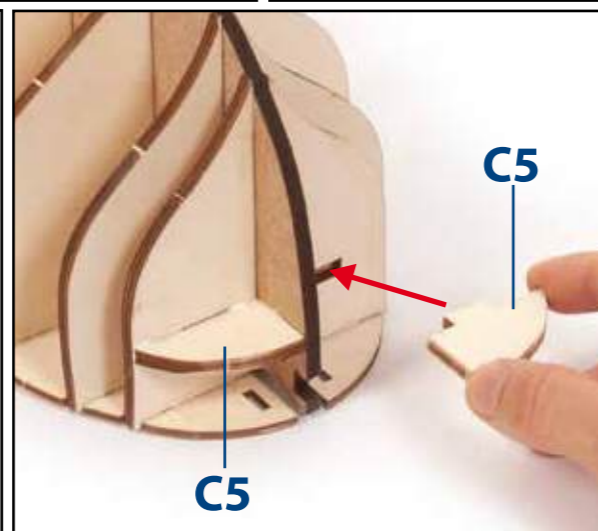
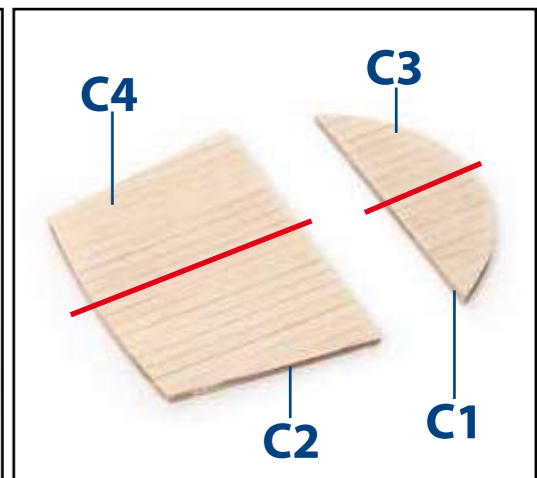
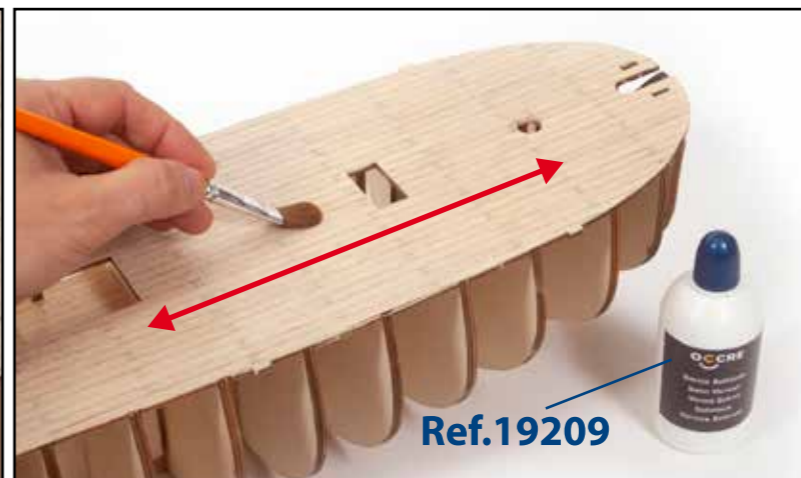
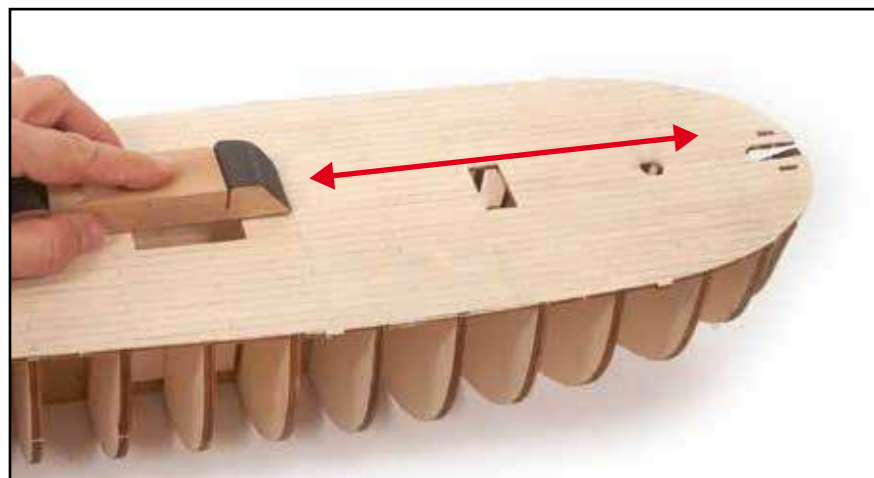
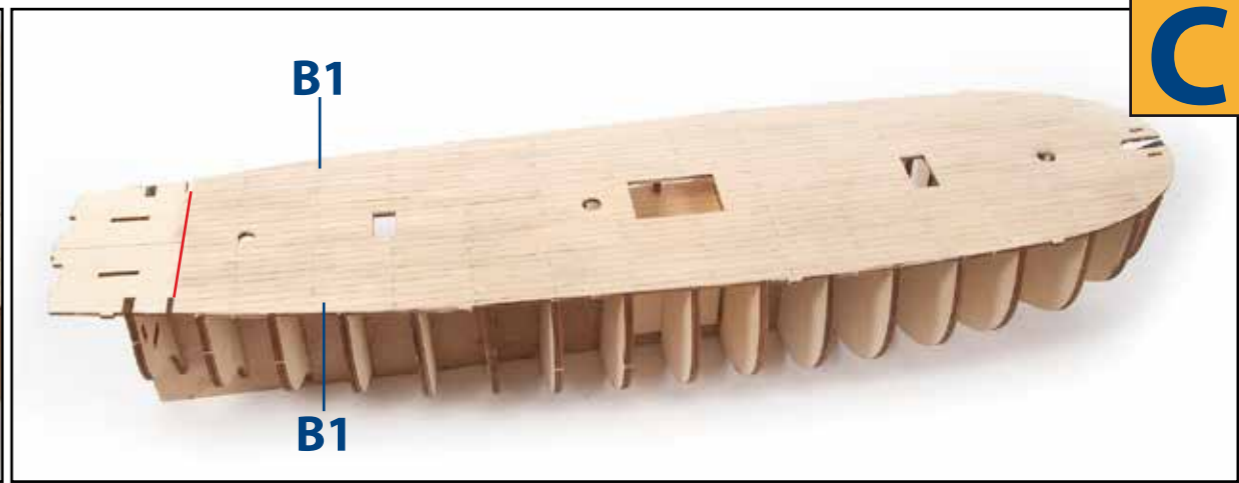
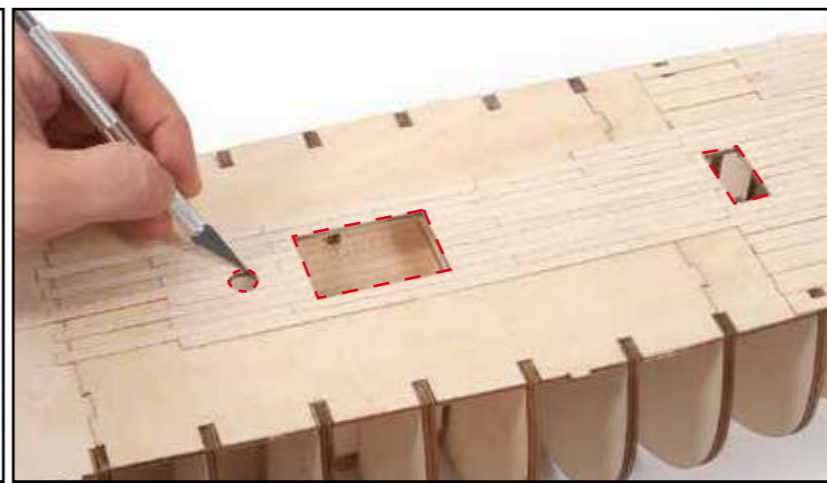
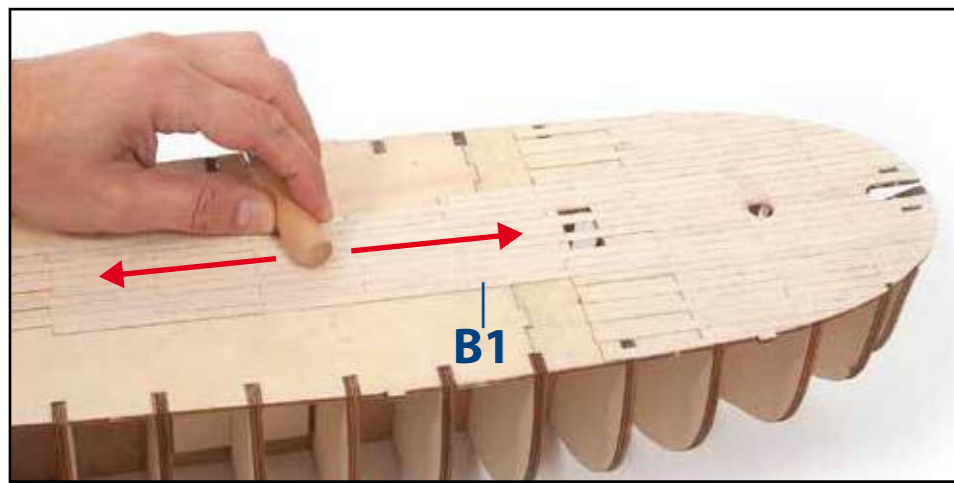

**D**

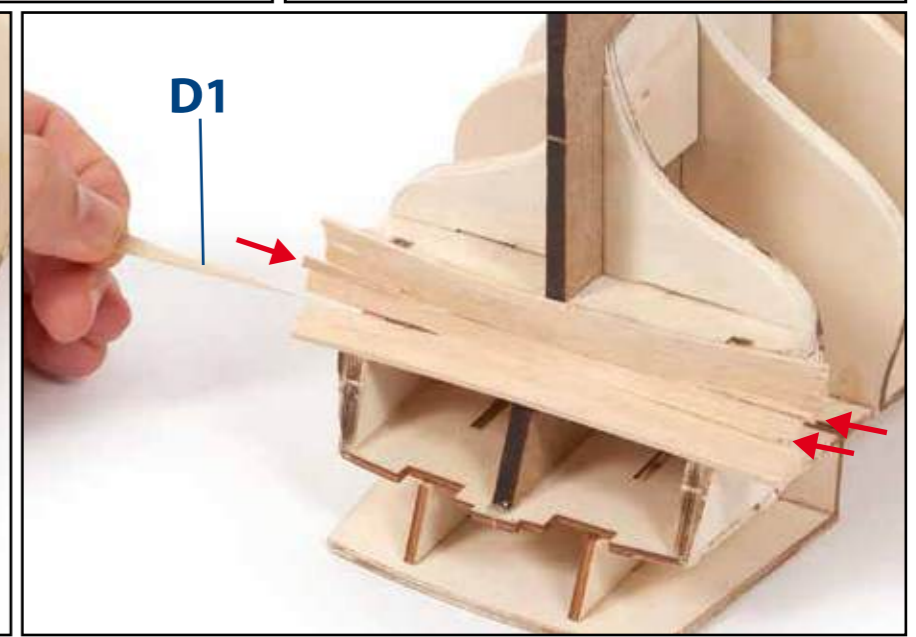
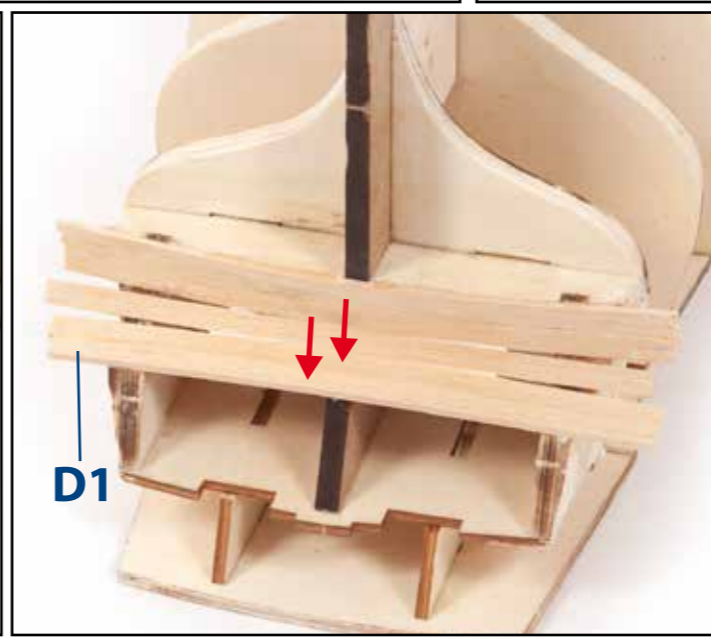
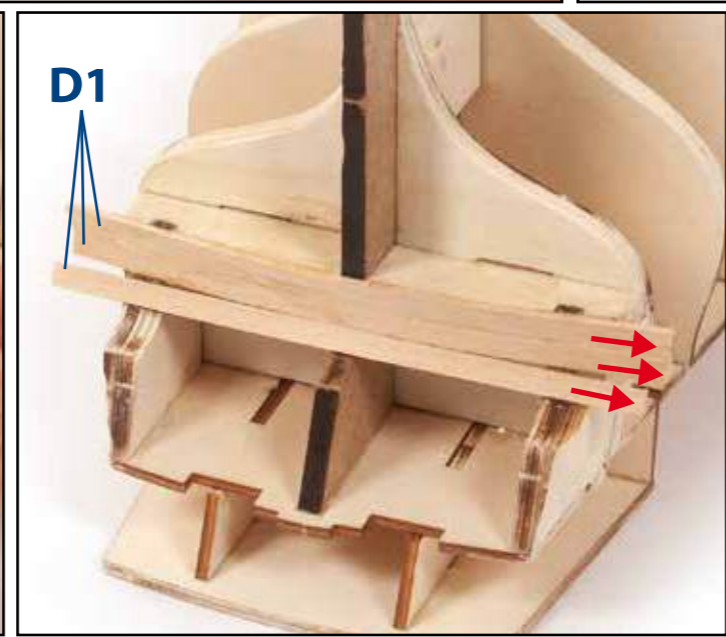
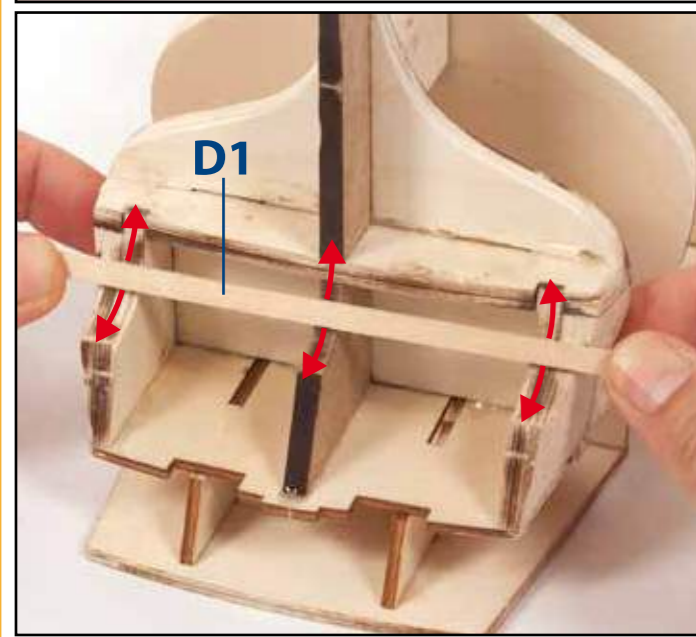
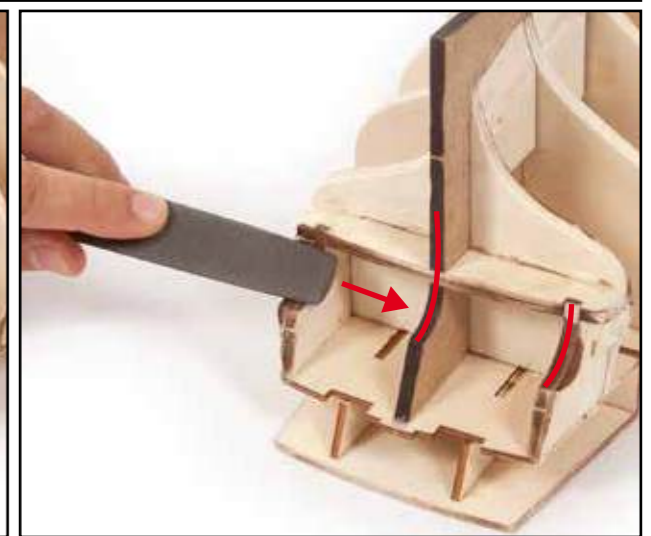
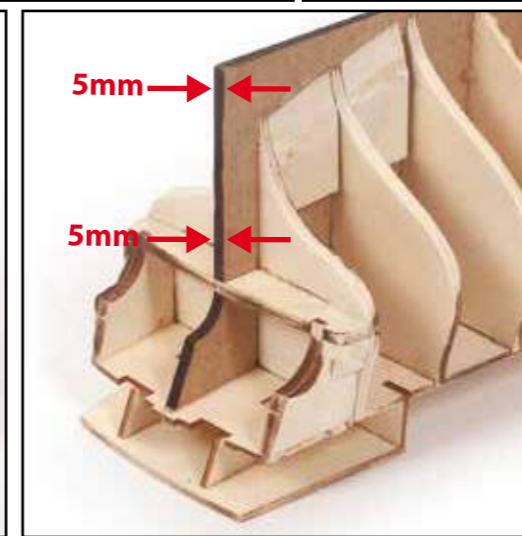
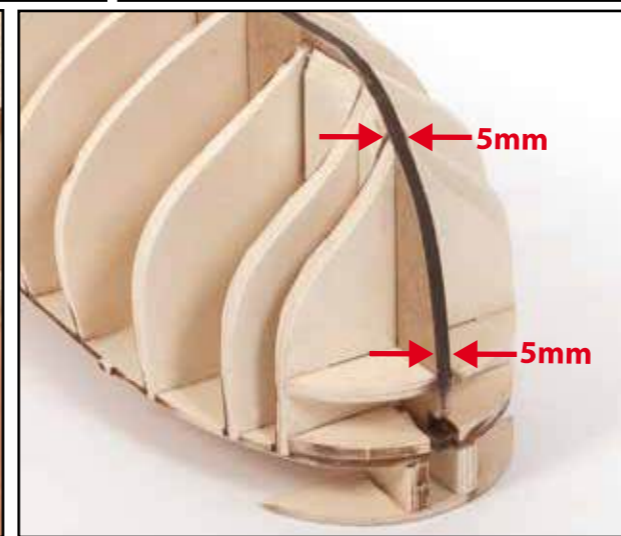
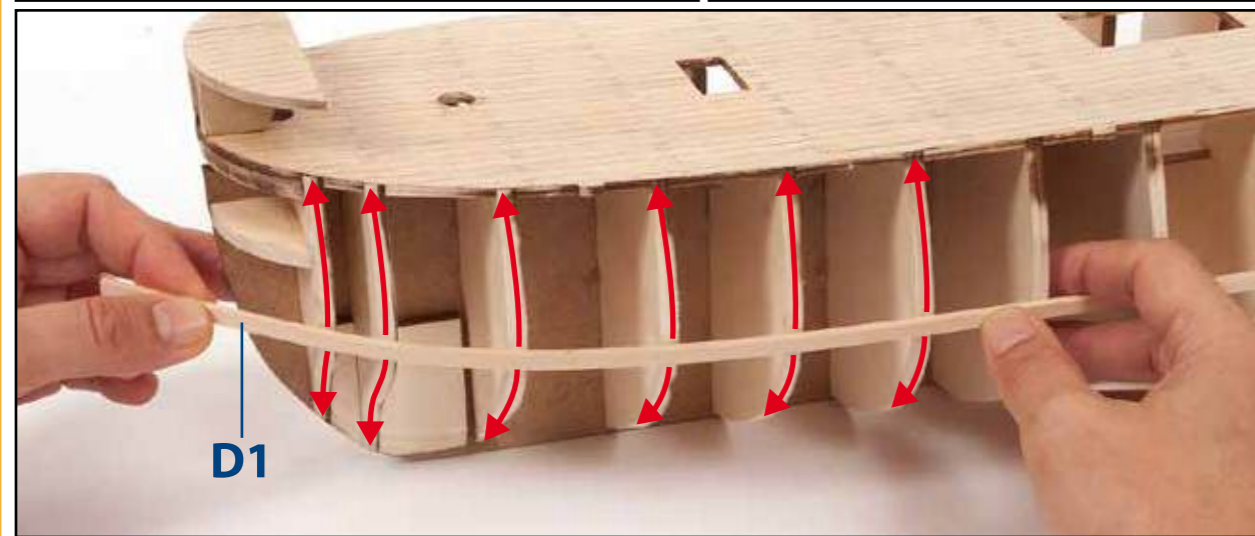
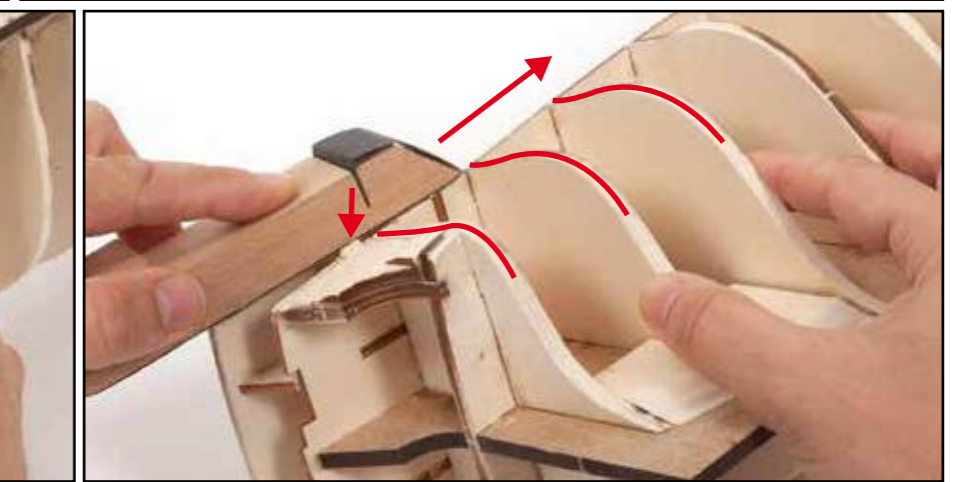
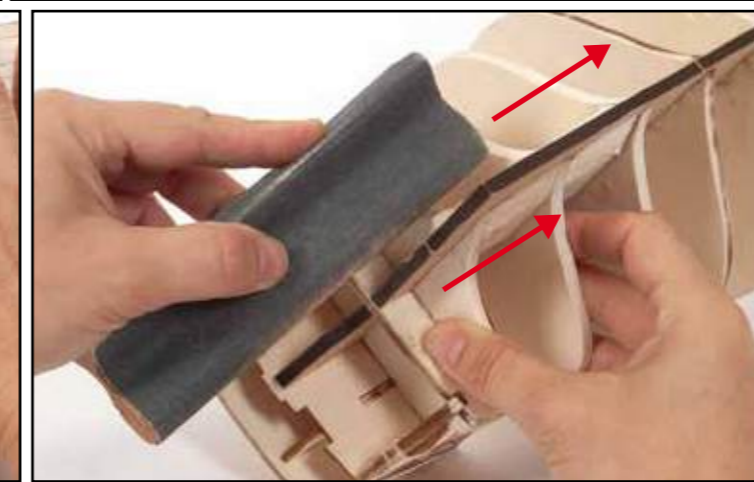
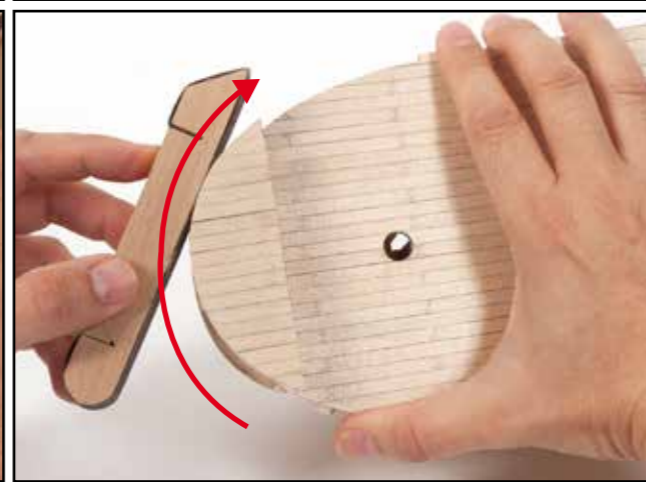
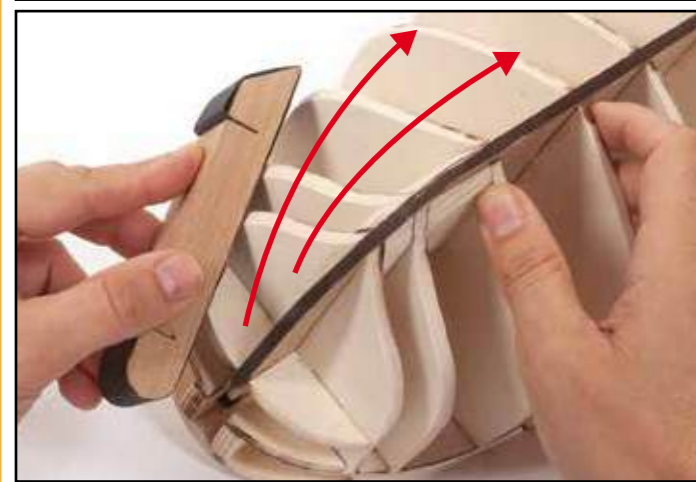
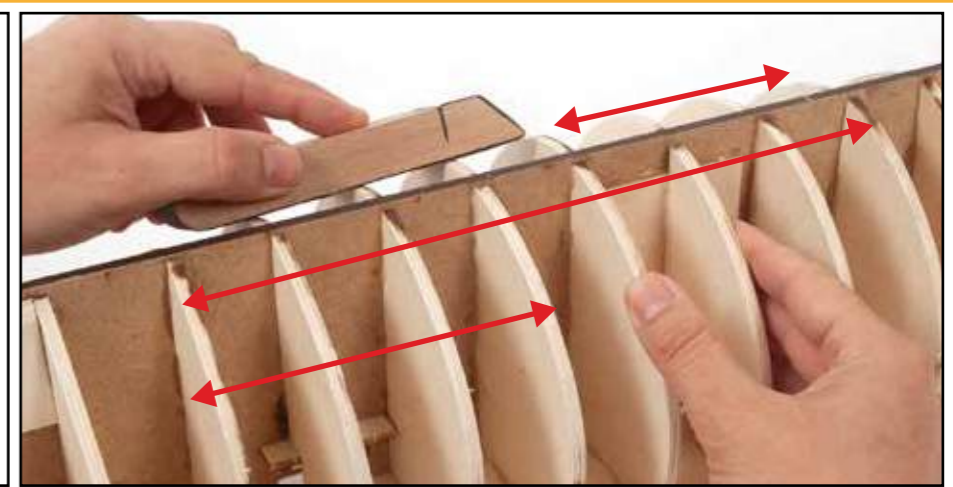
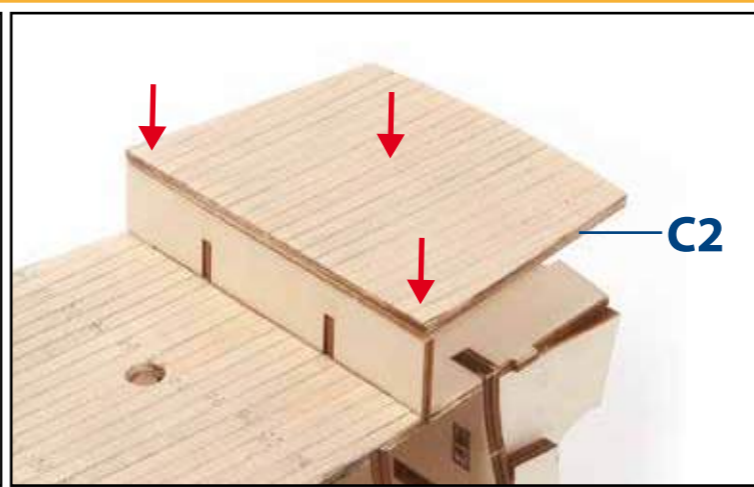
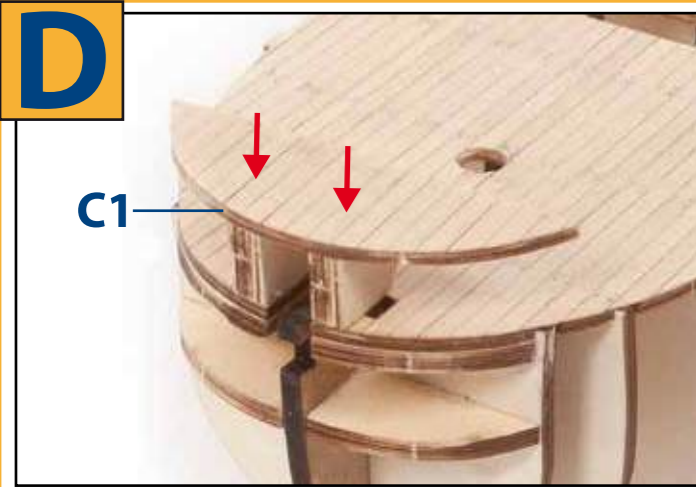

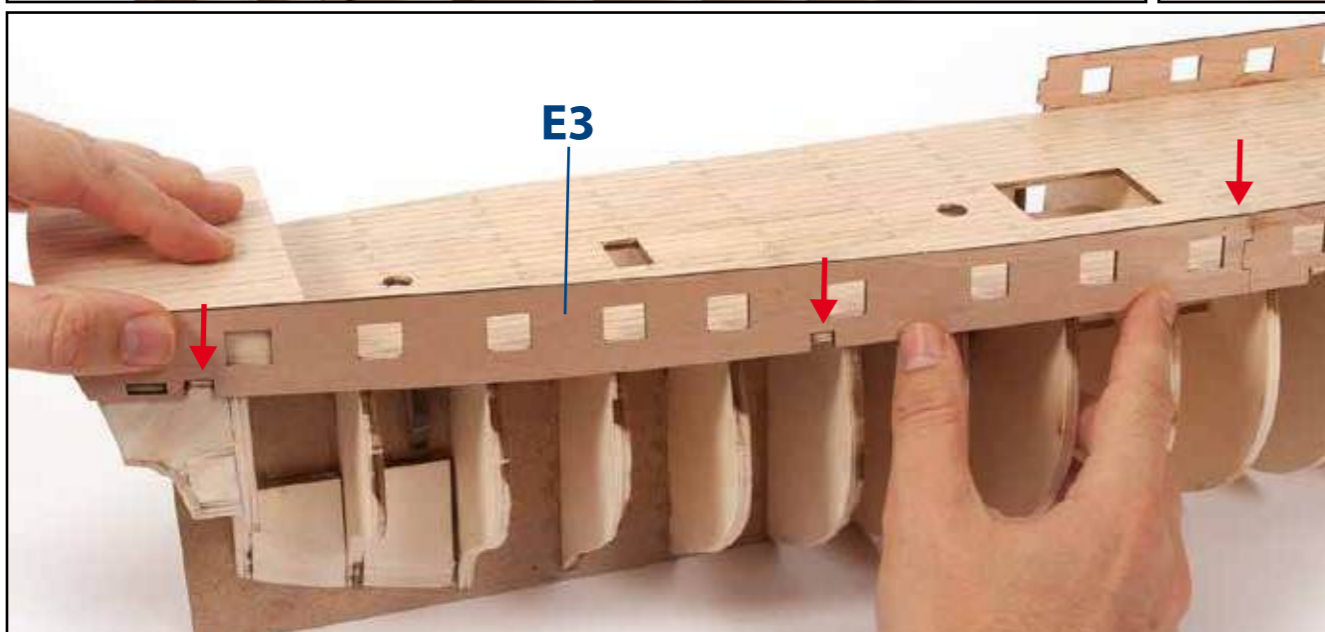
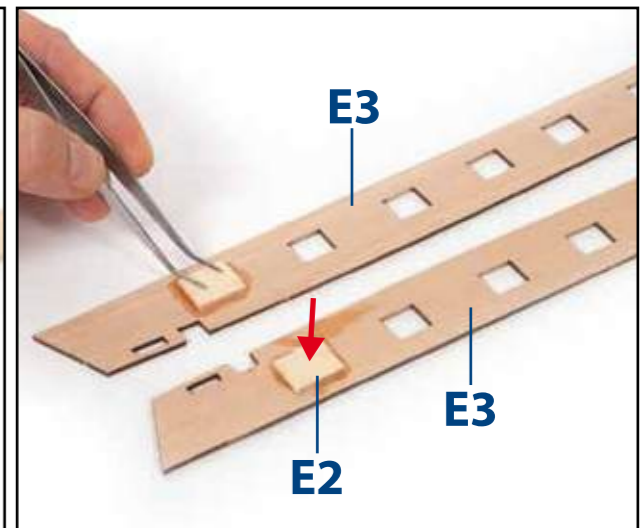
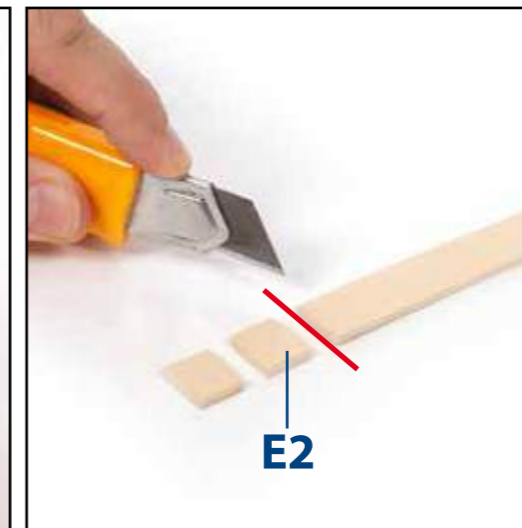
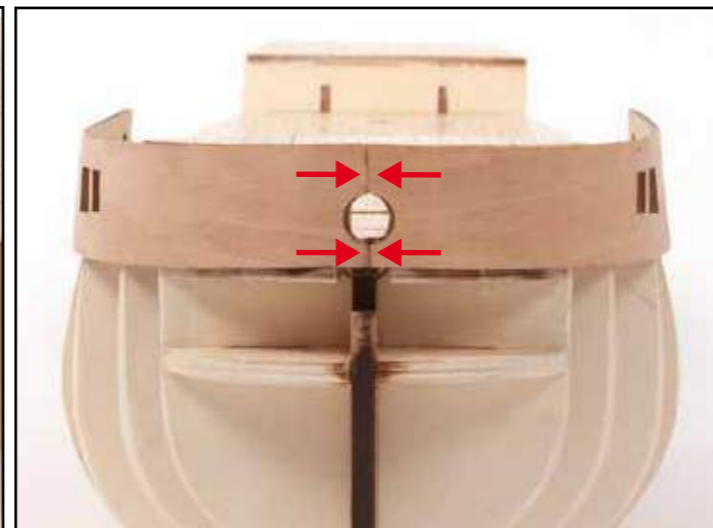
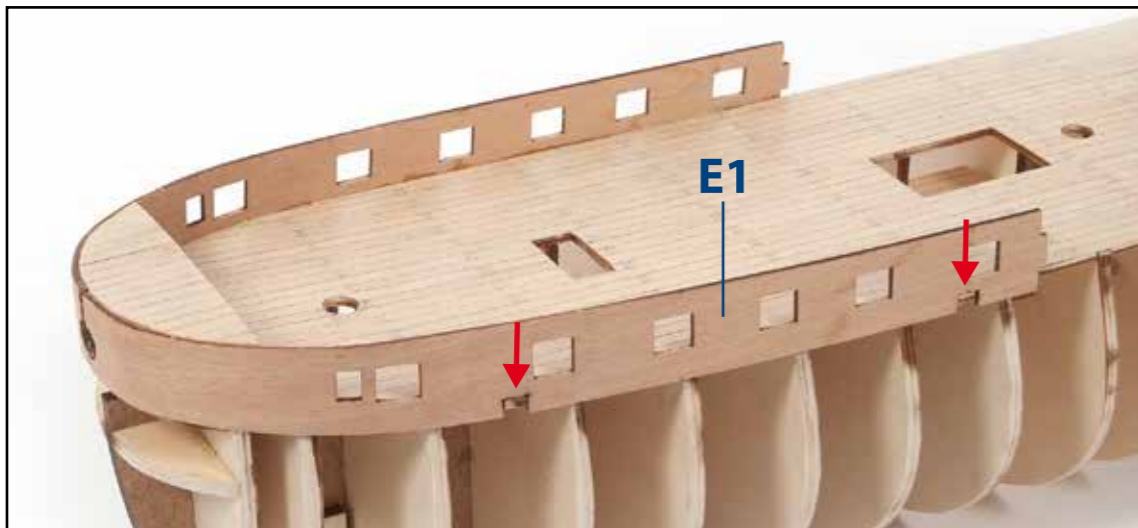
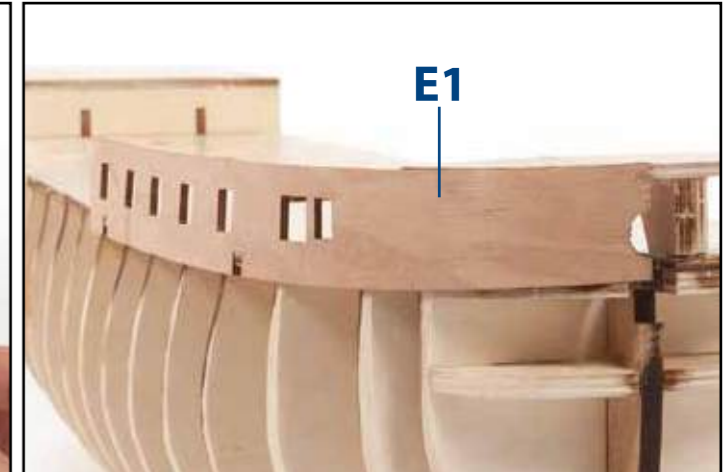
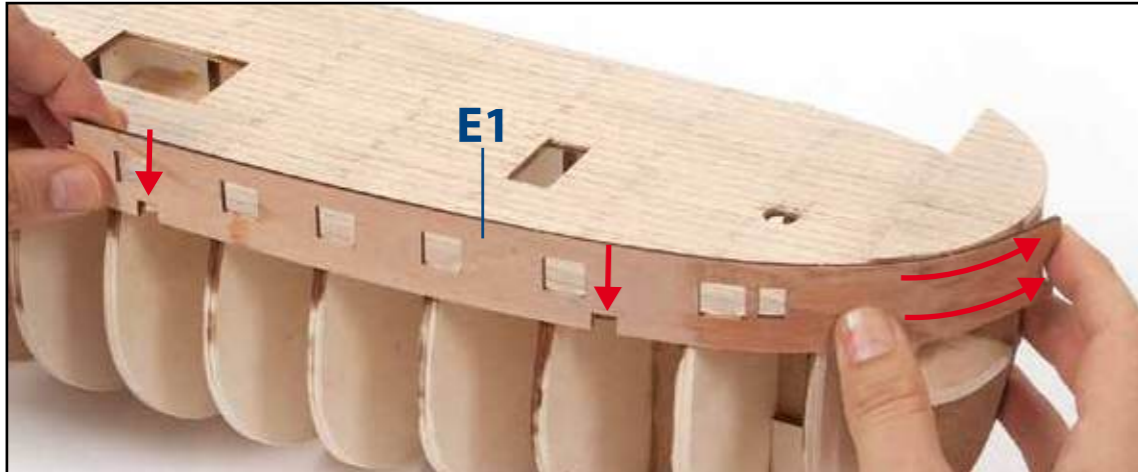
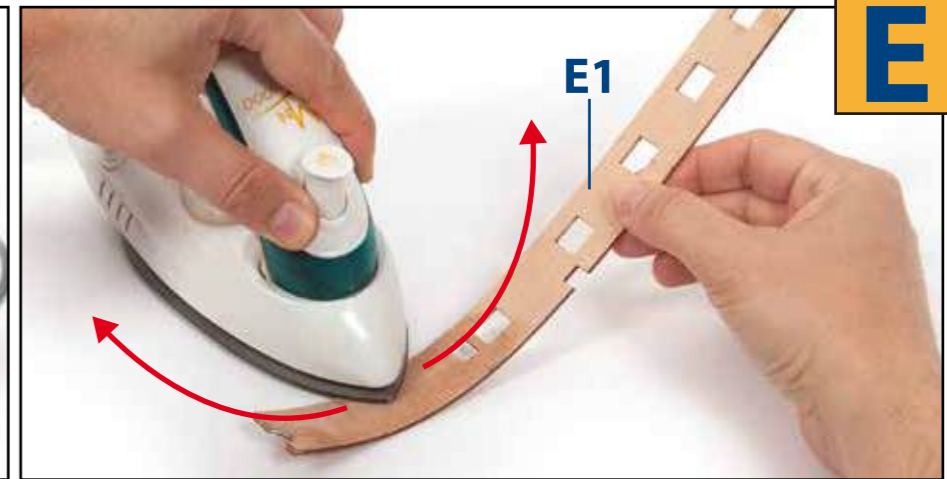
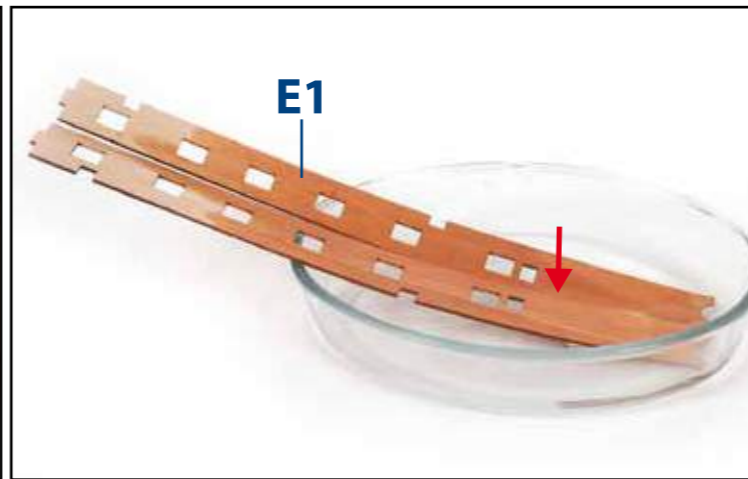
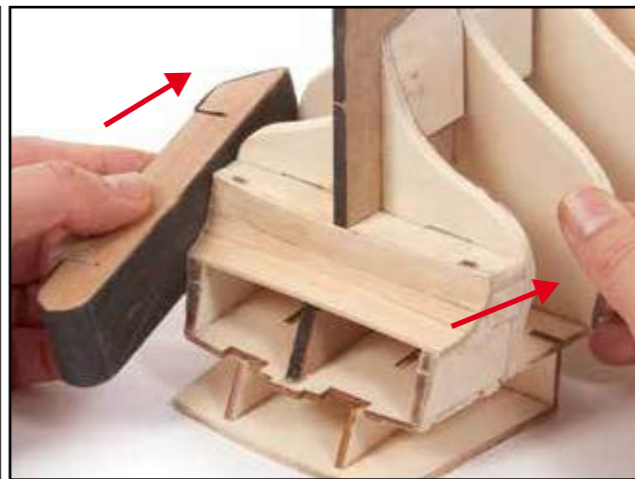

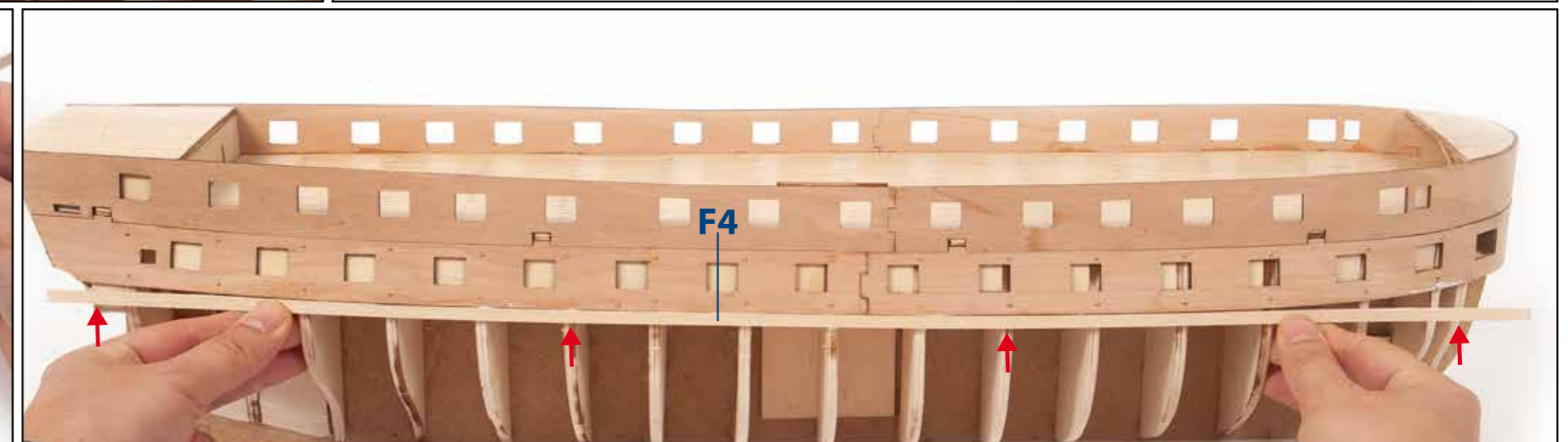
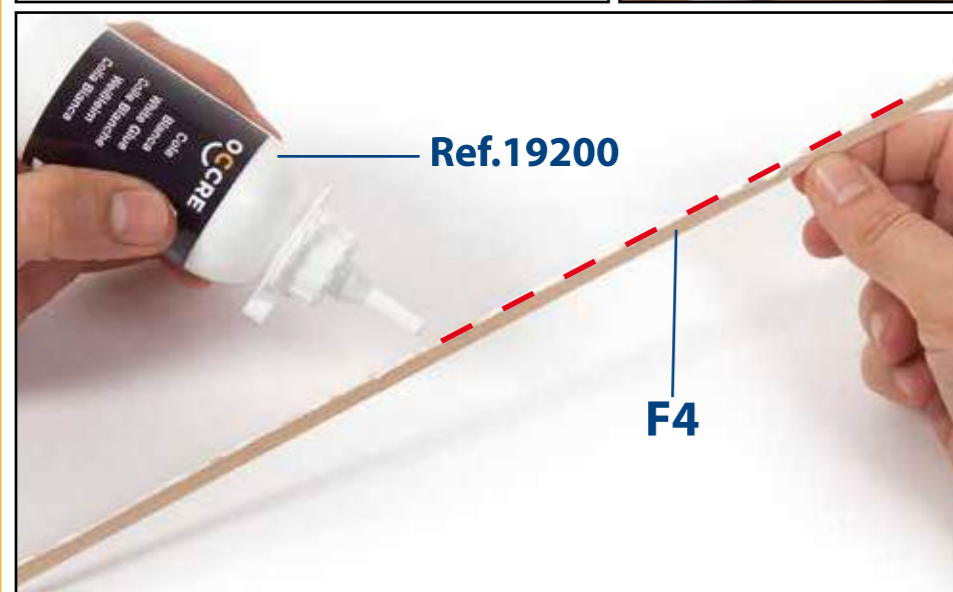
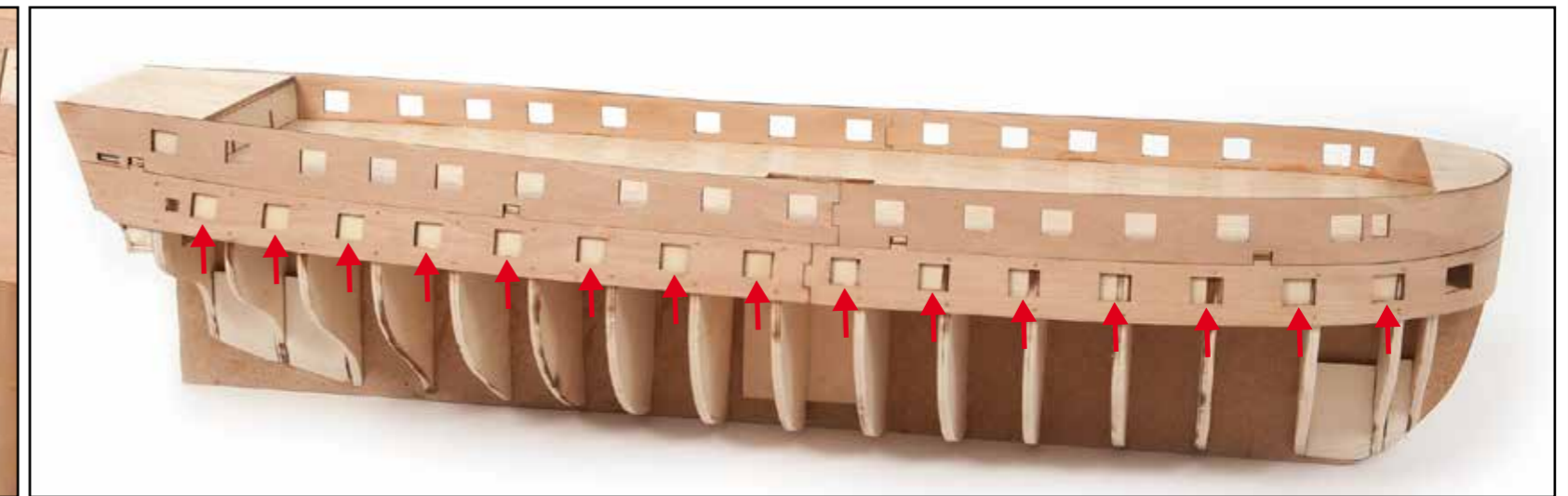
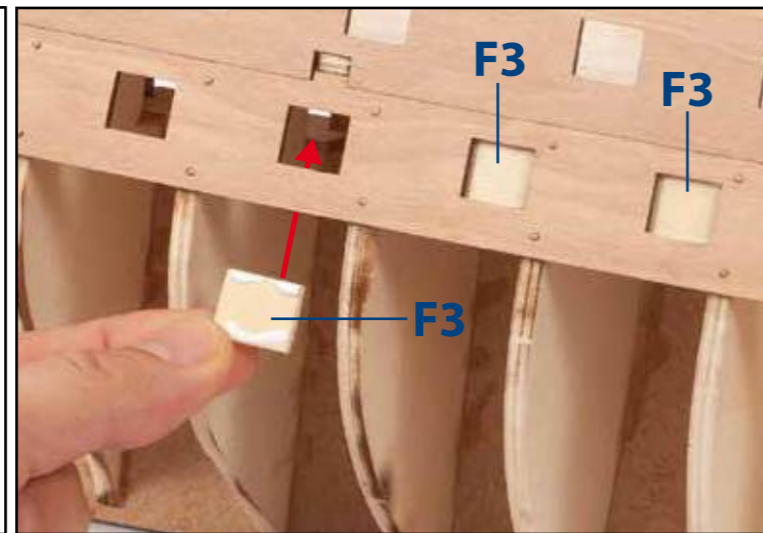
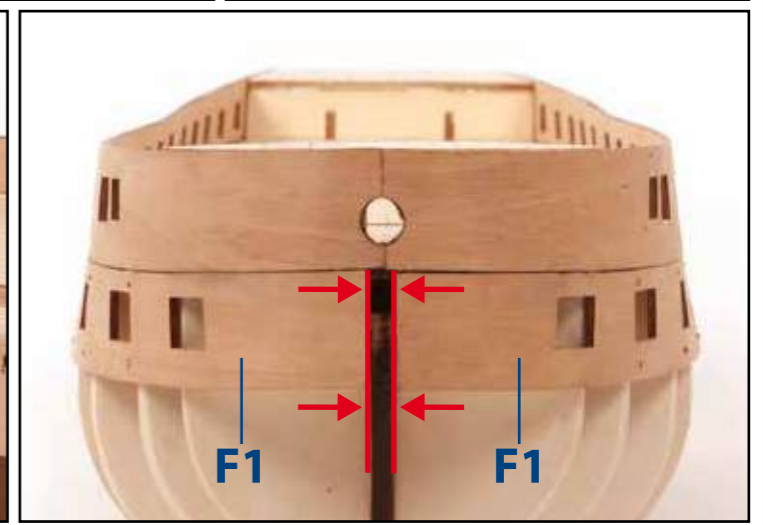
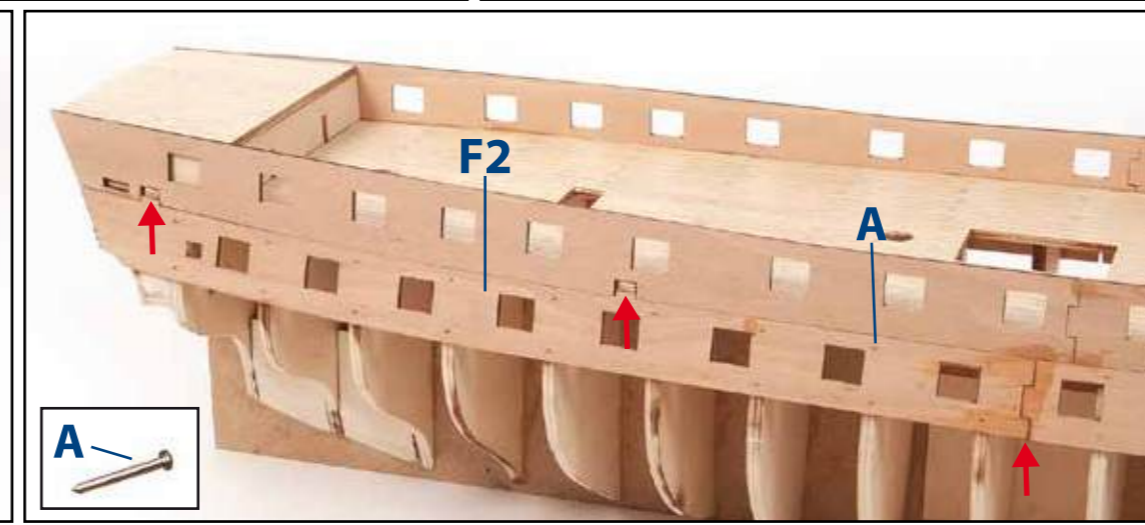
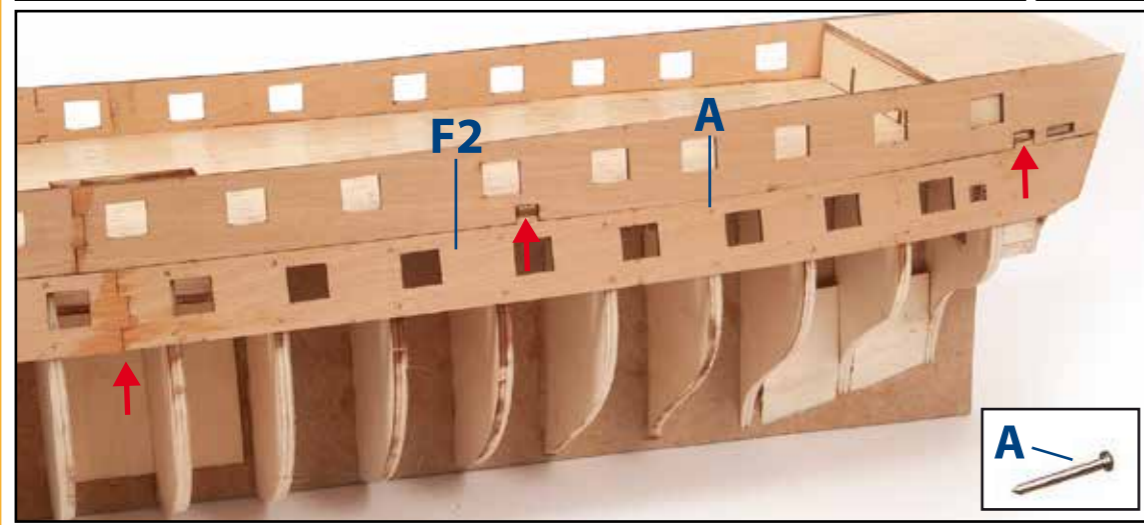
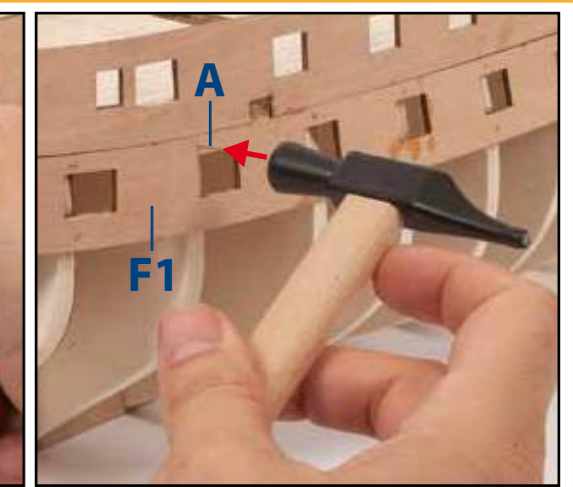
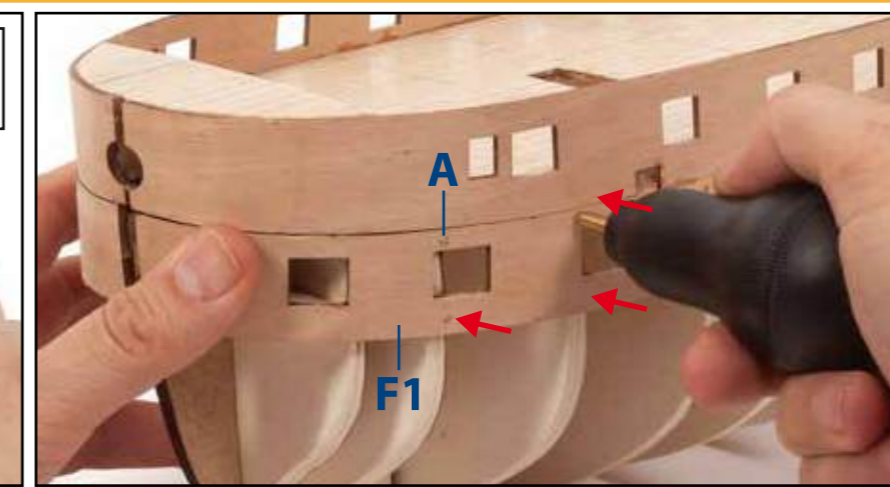
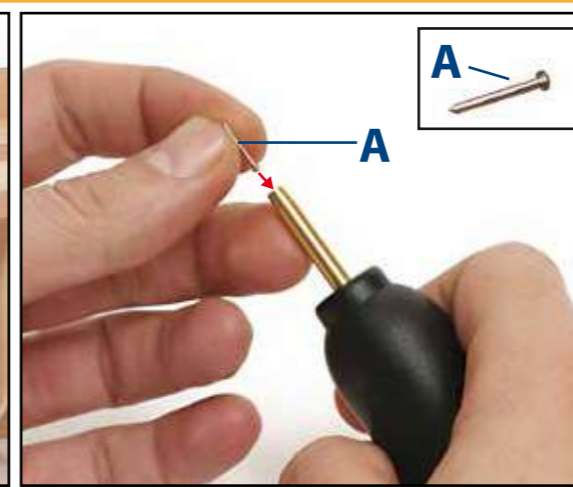
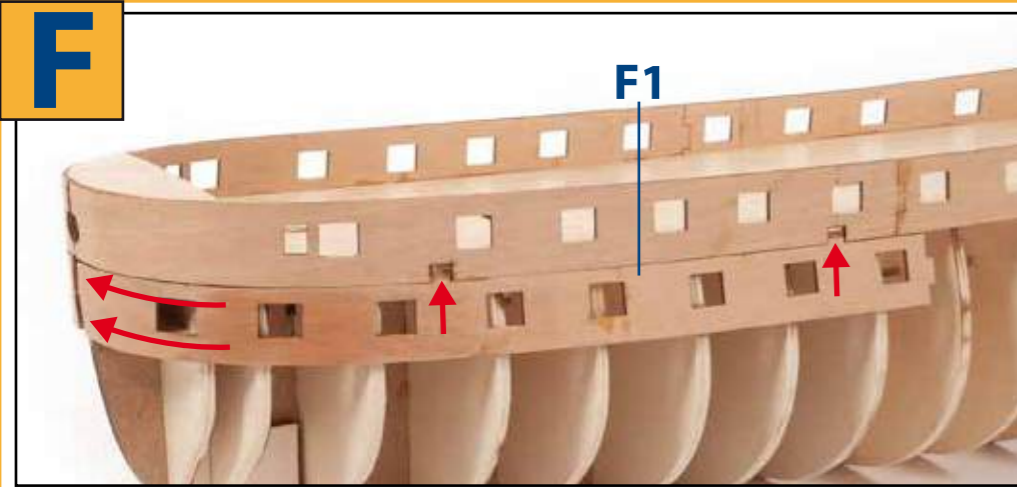
**F**

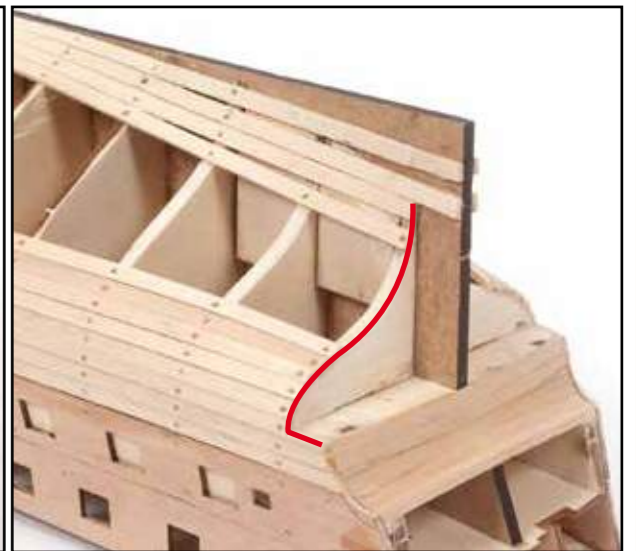
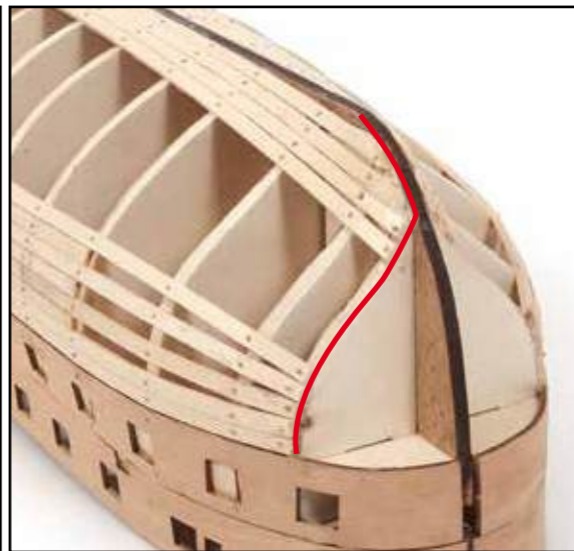
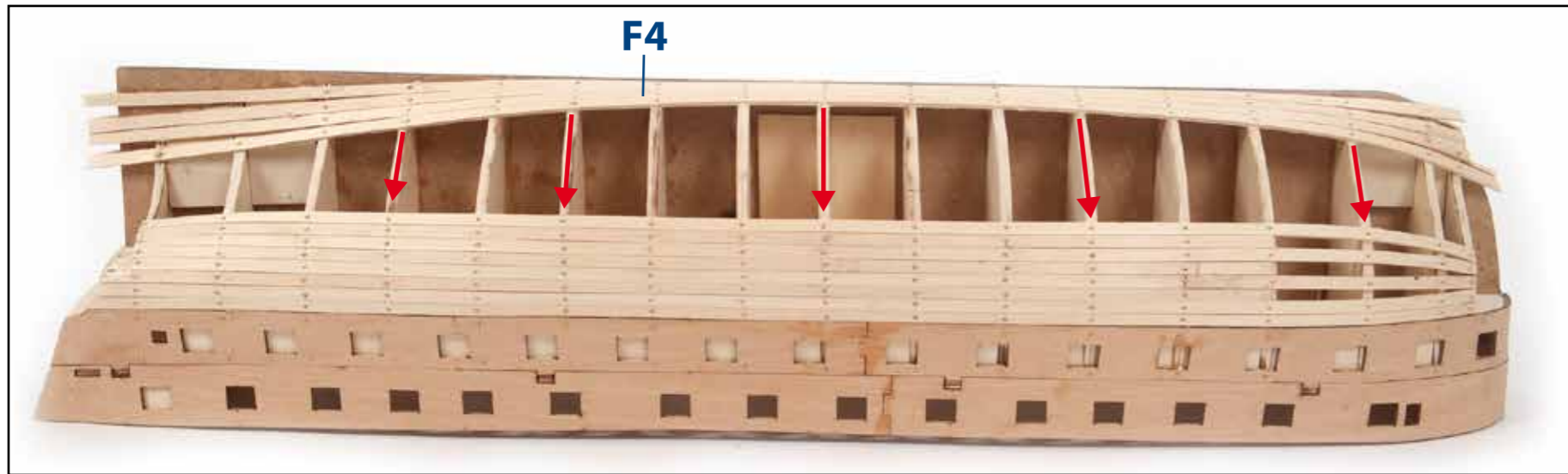
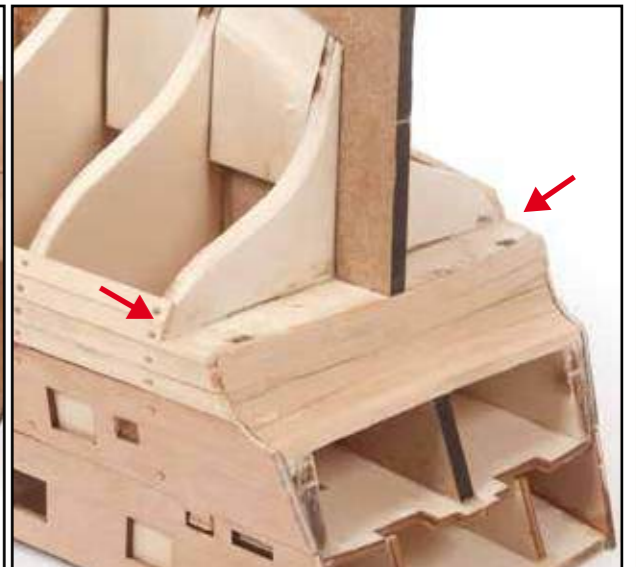
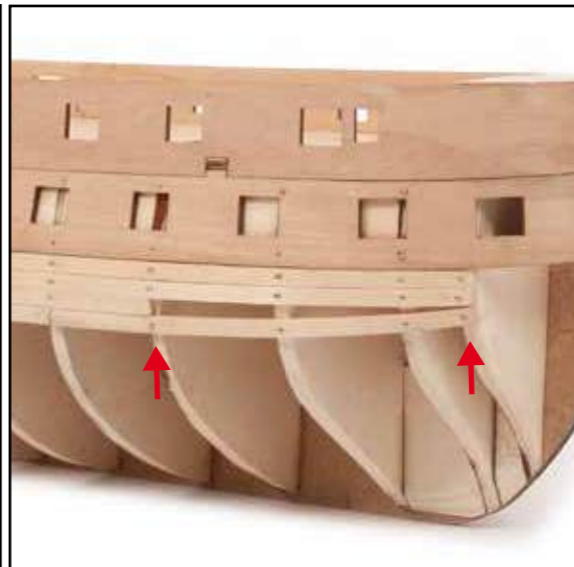
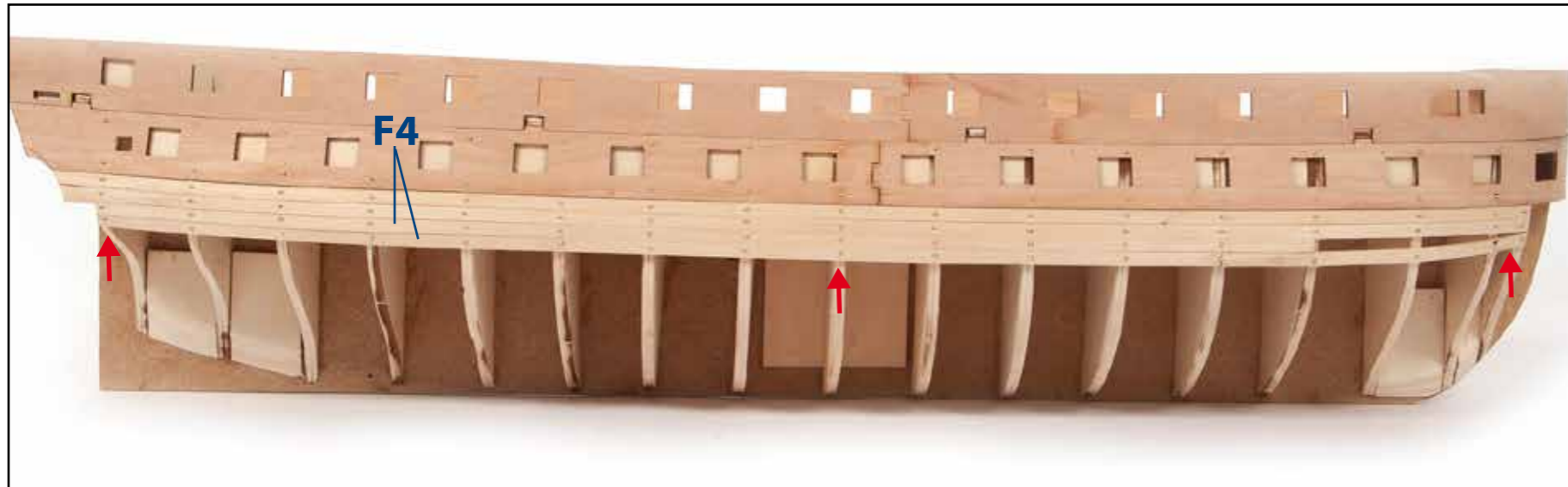
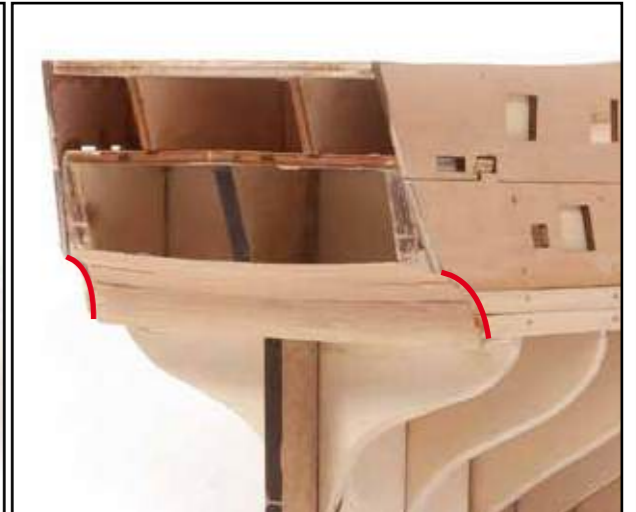
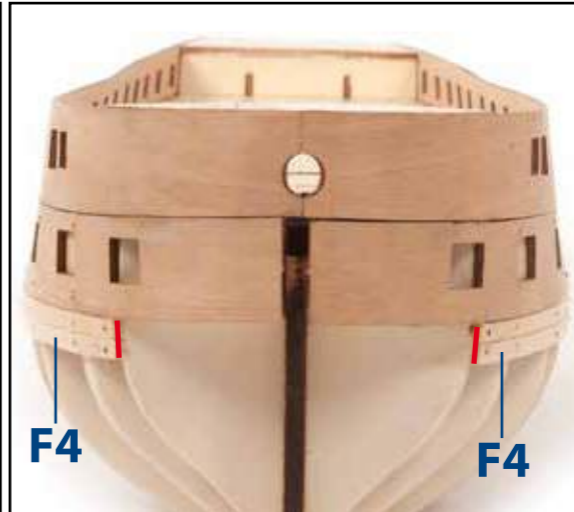
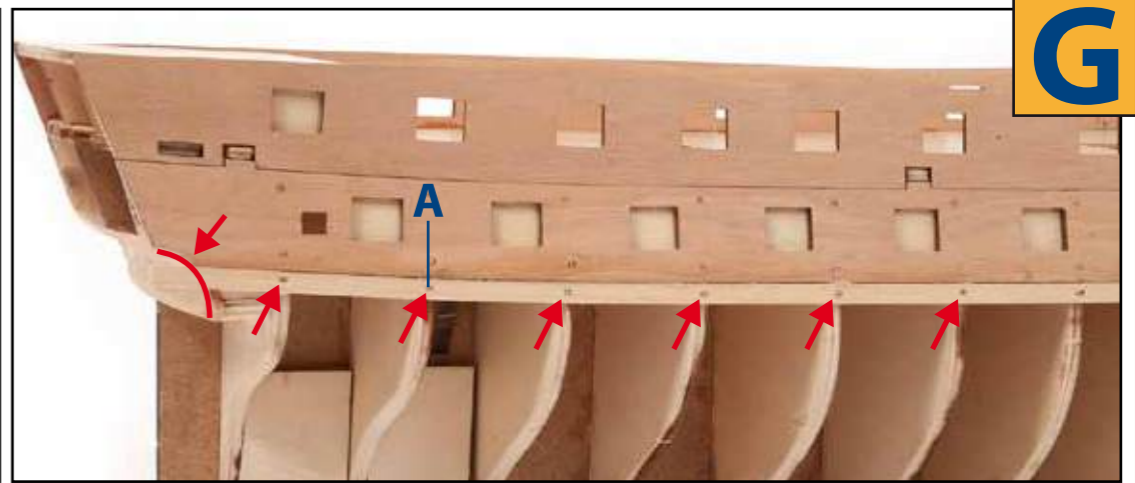
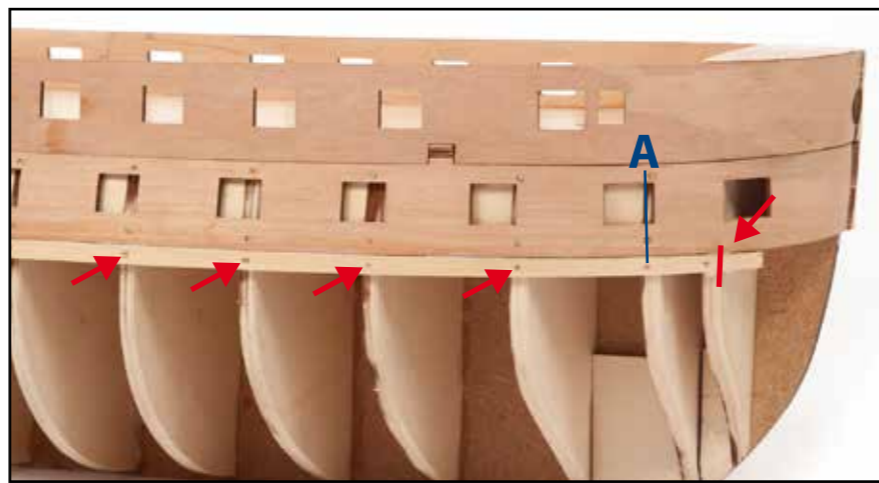
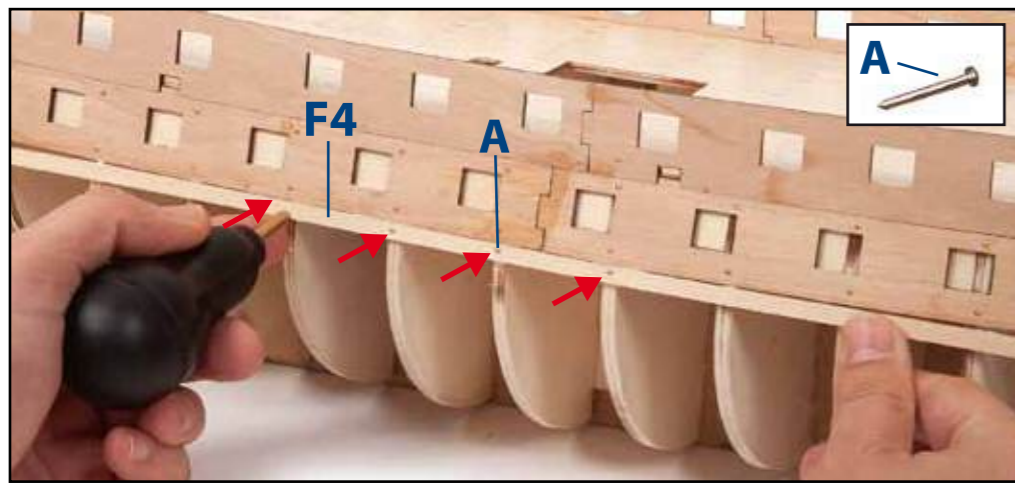

**H**

F4

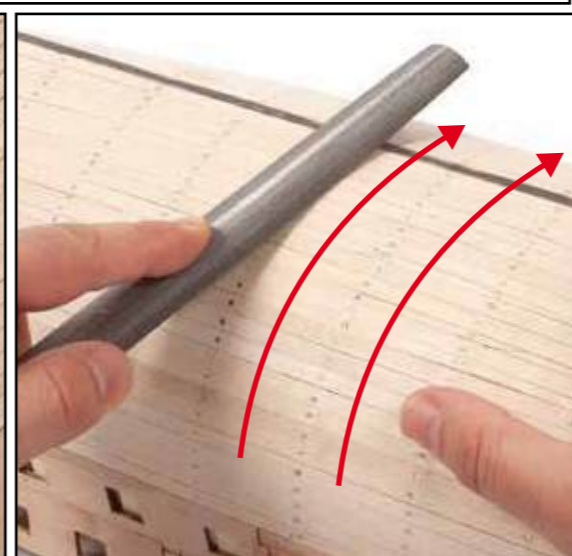
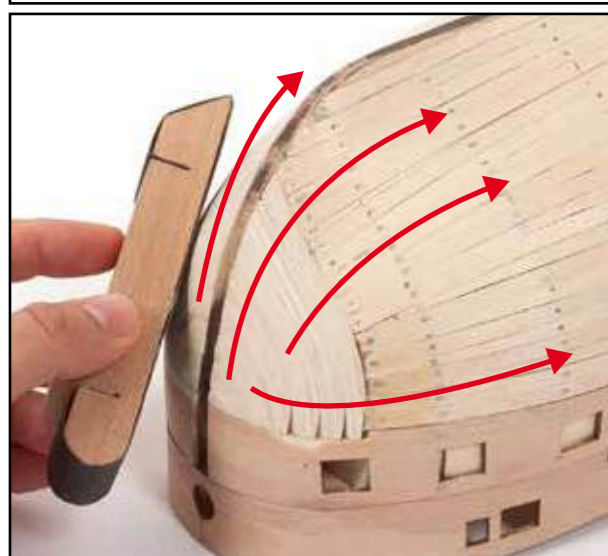
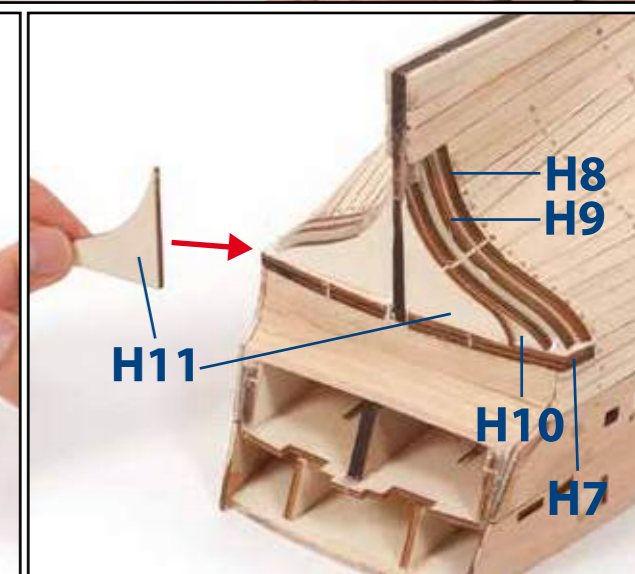
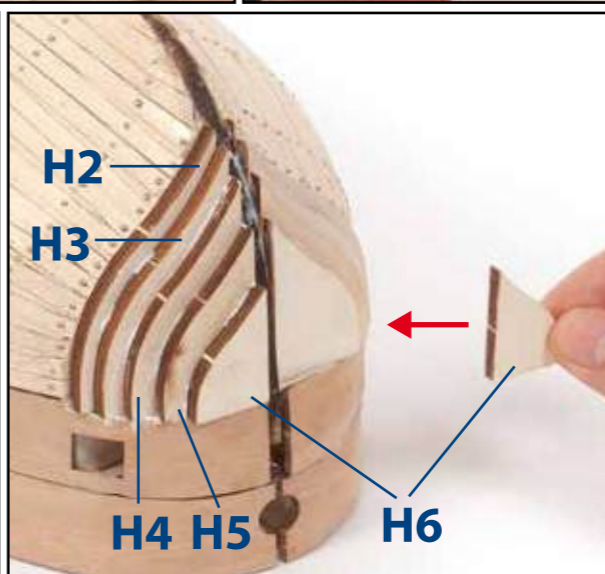
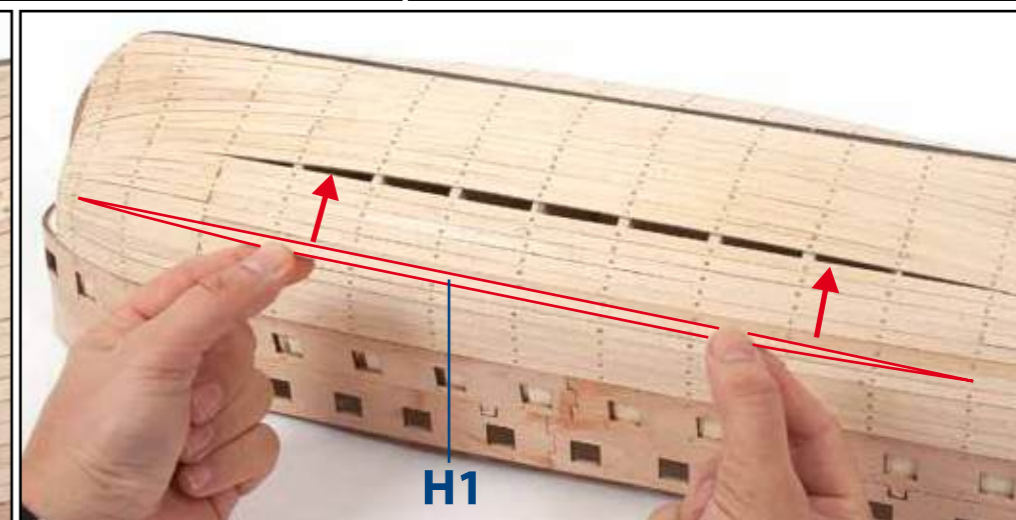
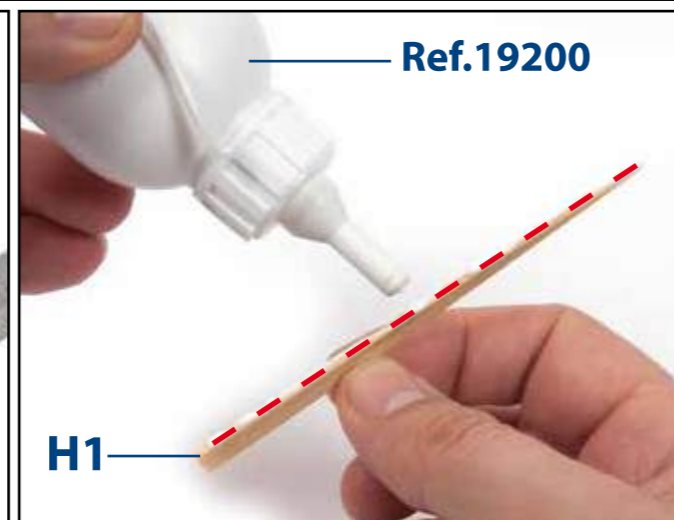
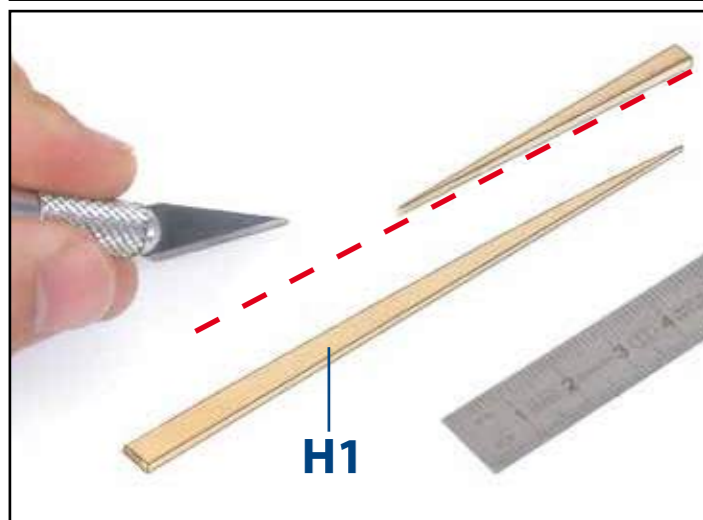
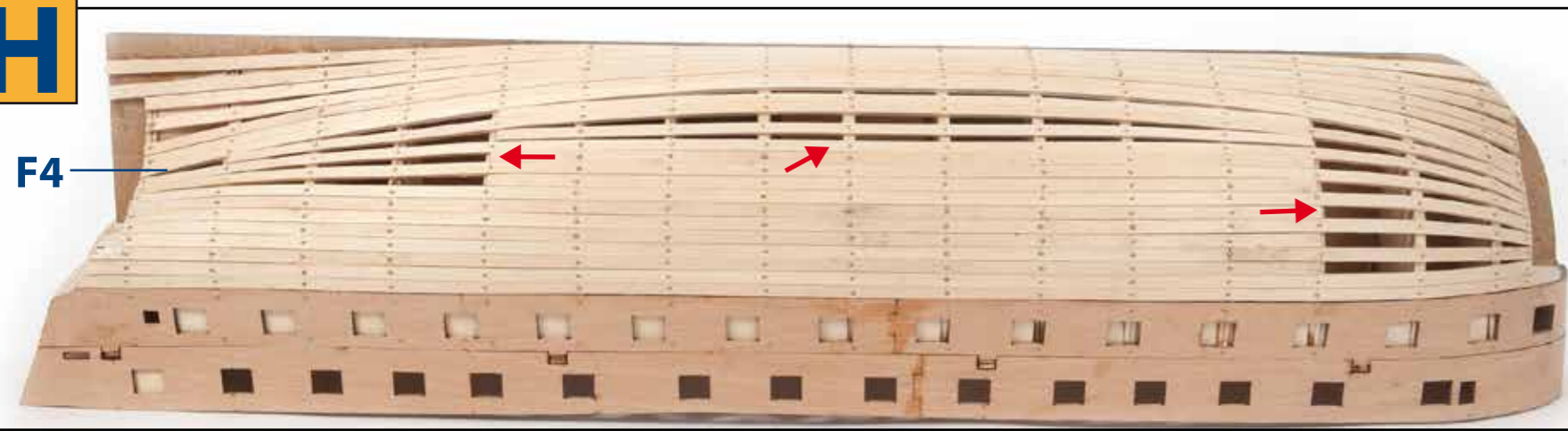

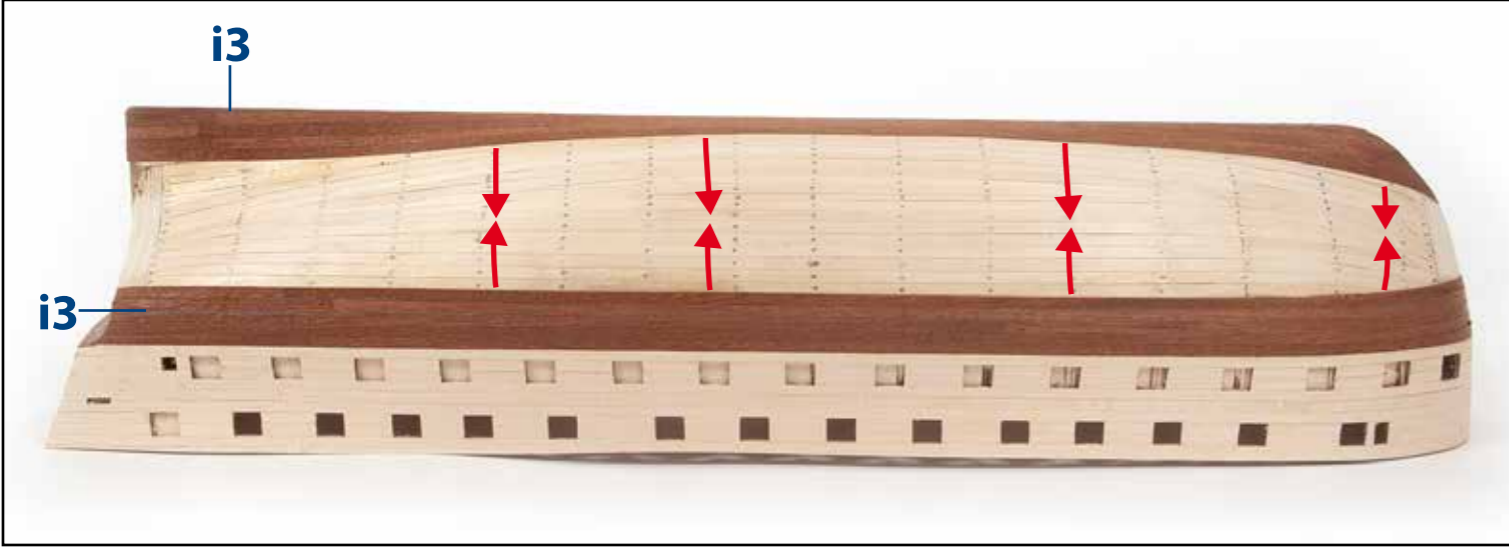
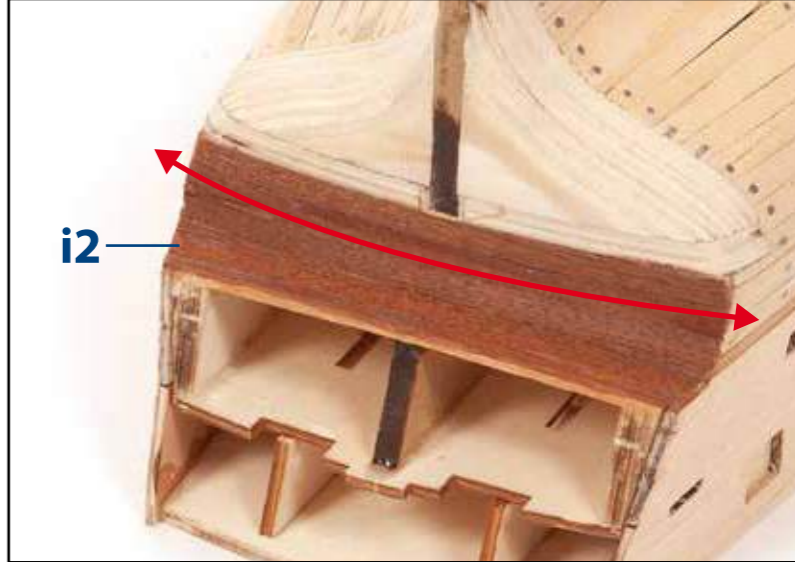
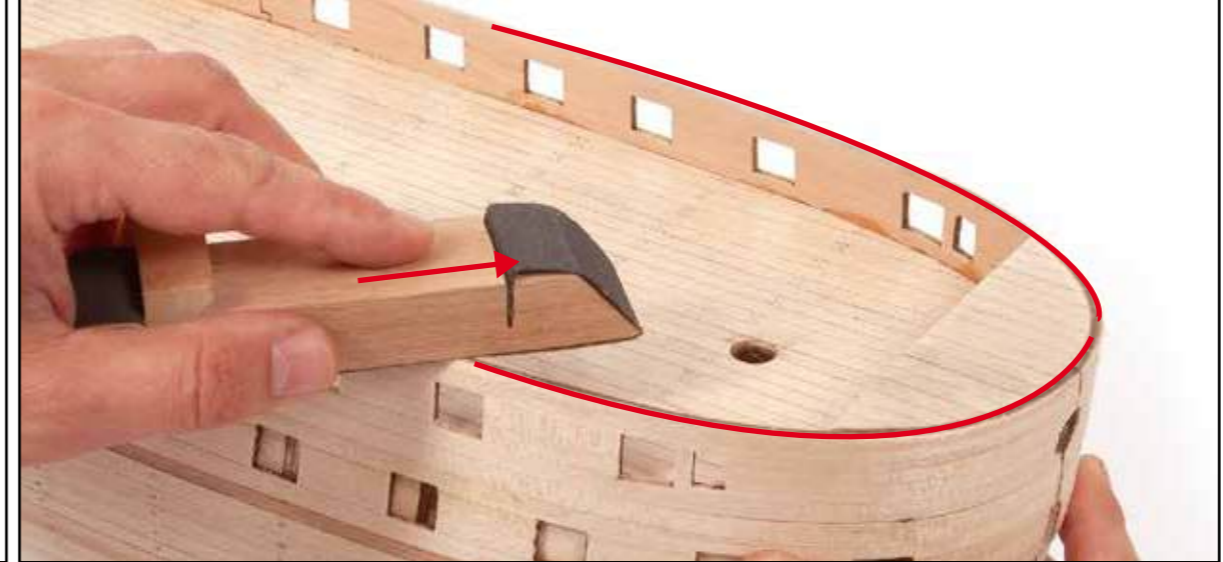
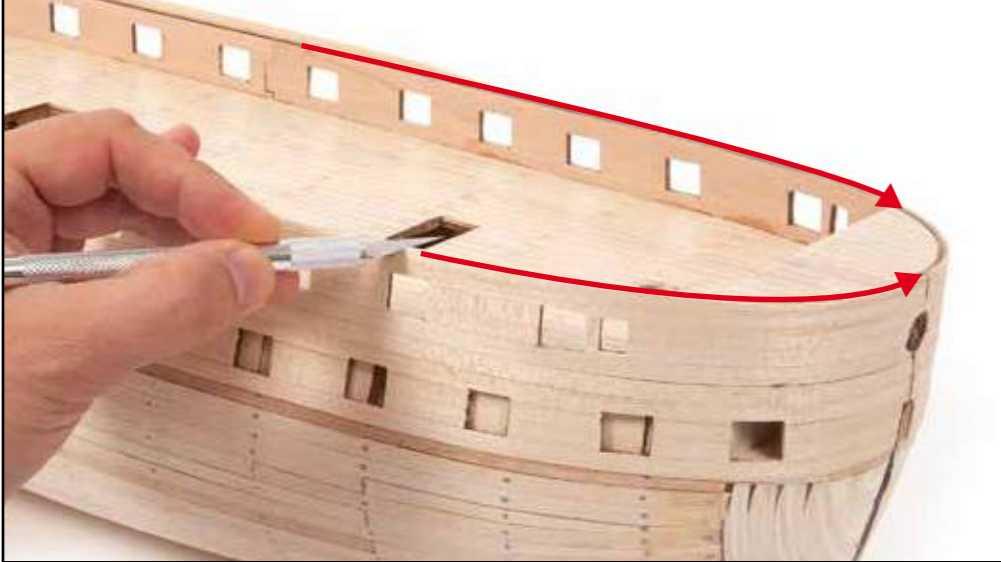
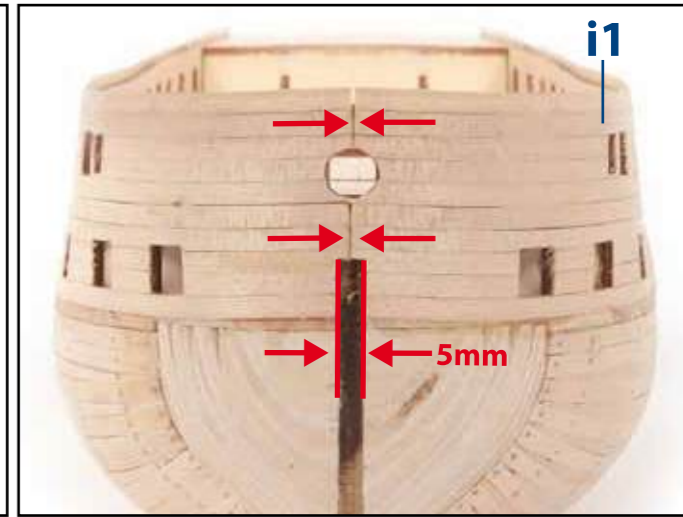
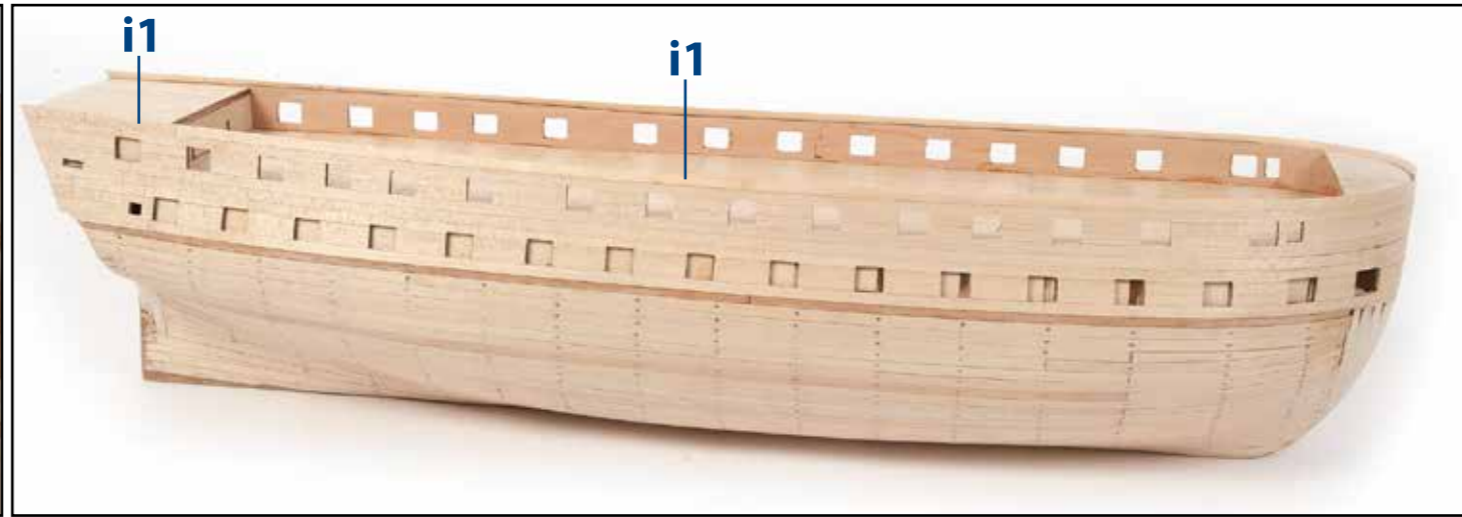
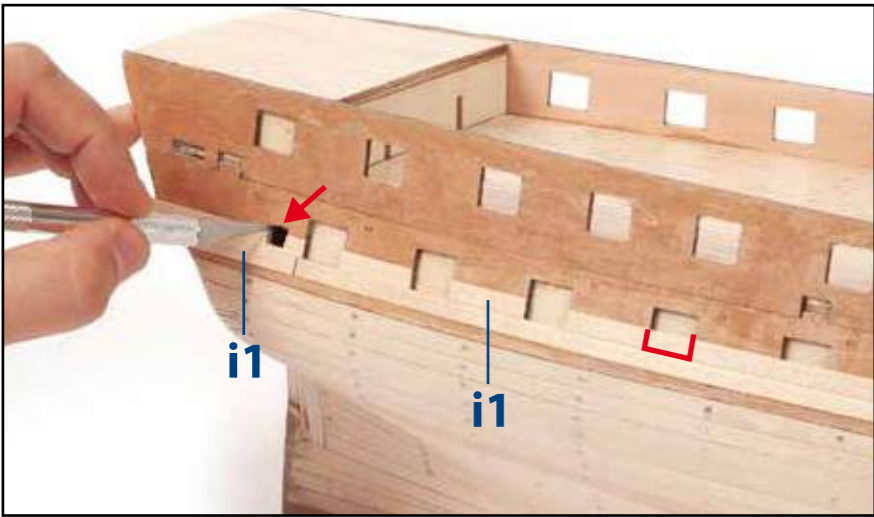
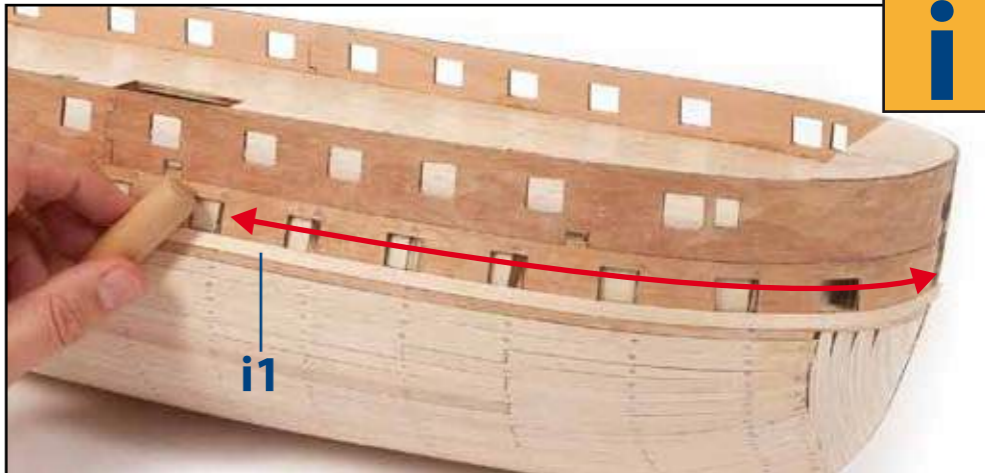
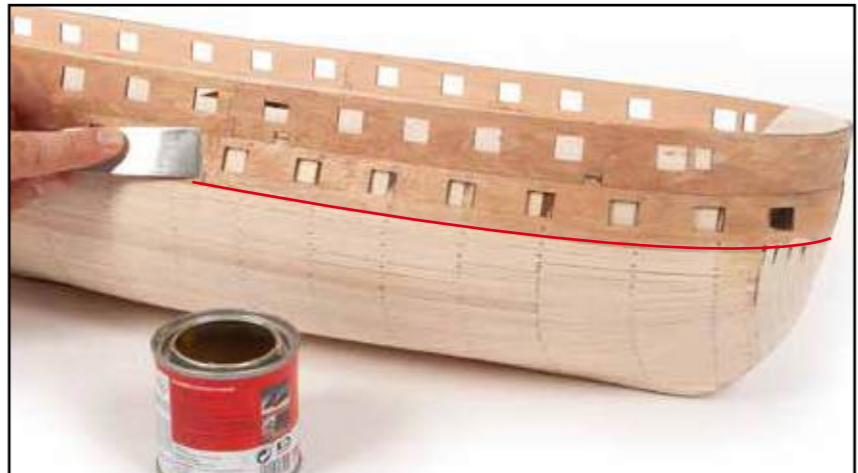
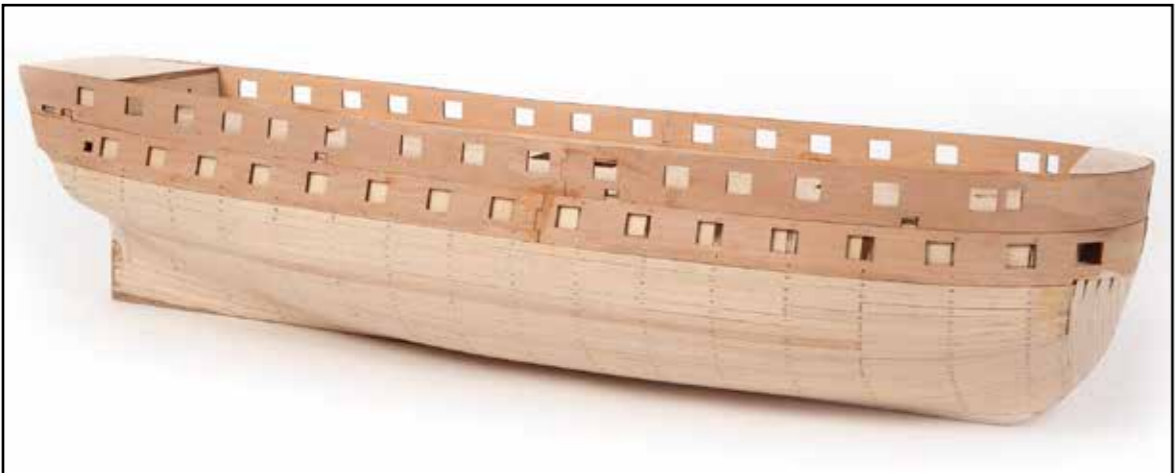

**J**

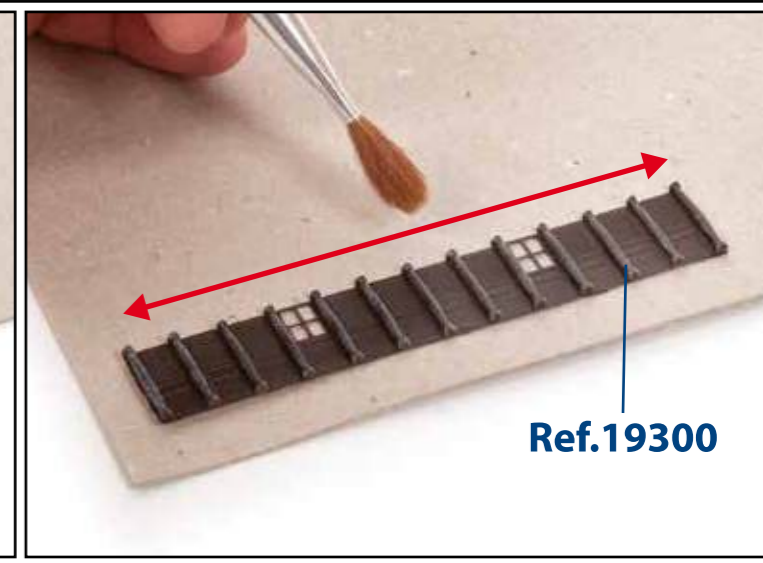
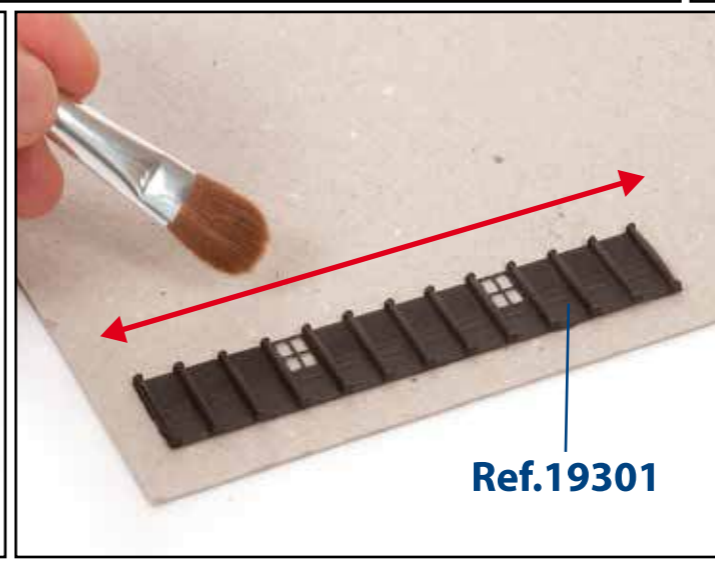
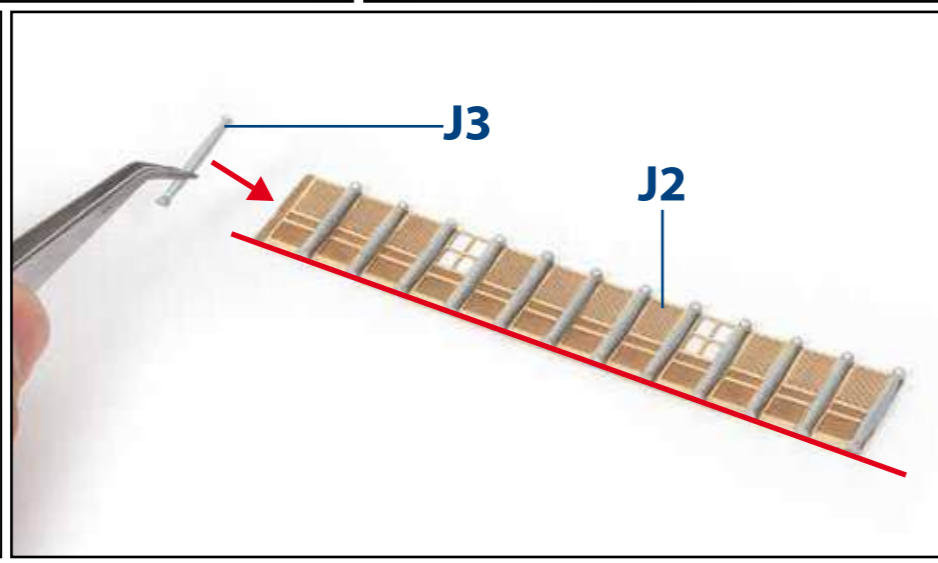
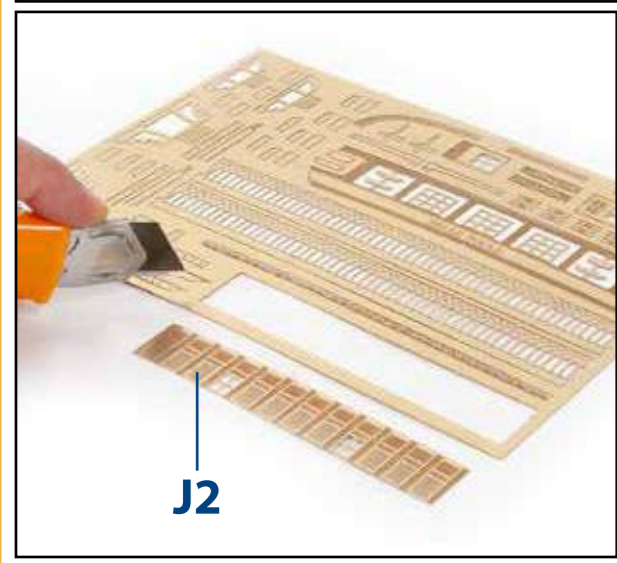
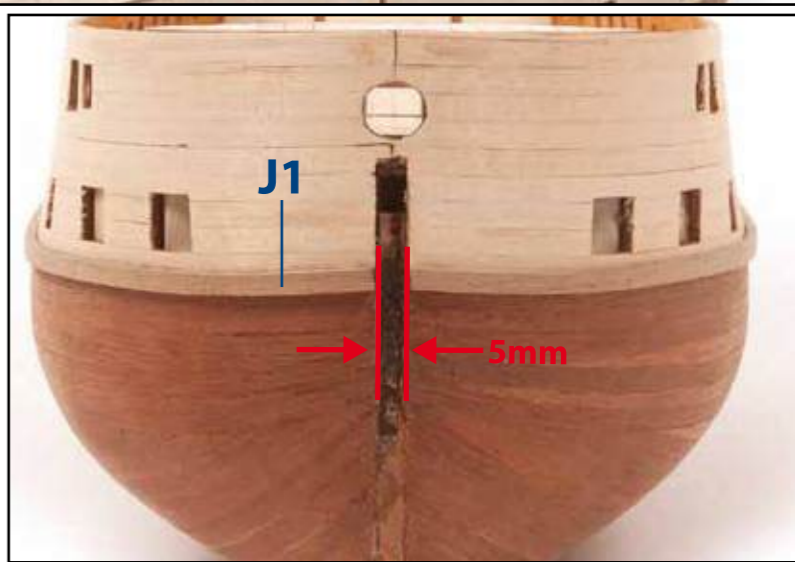
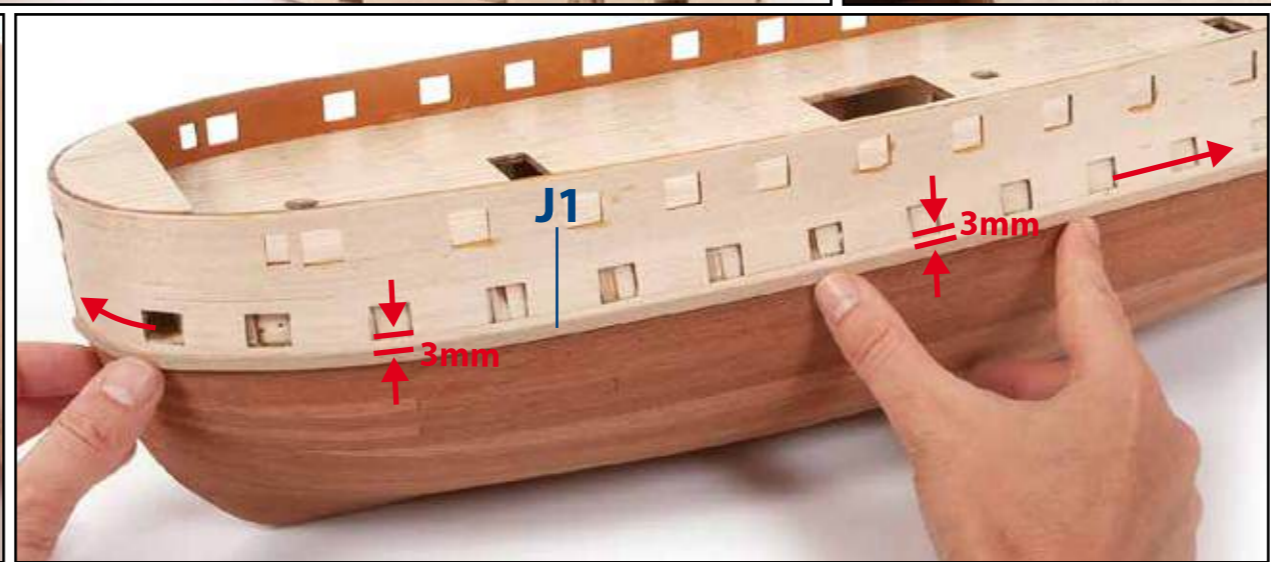
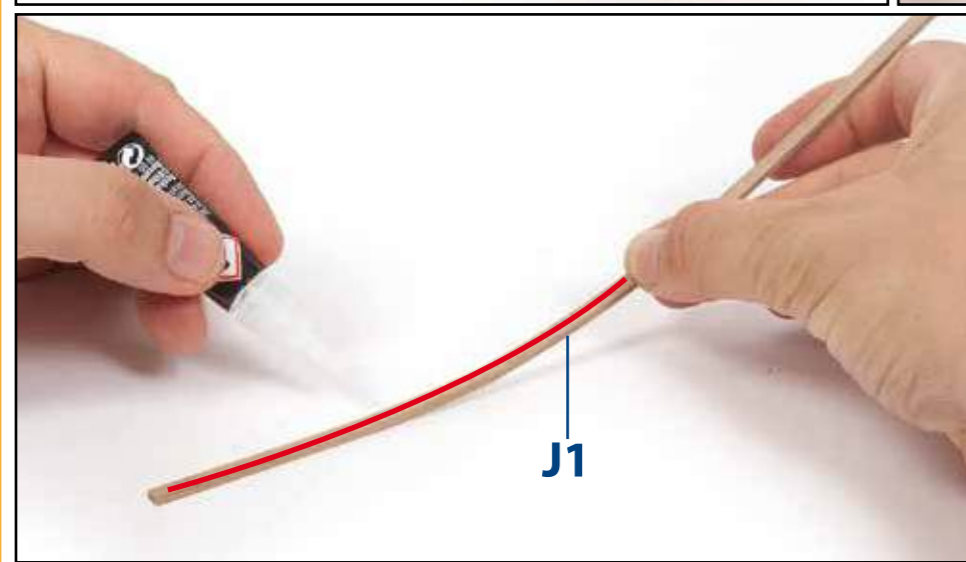
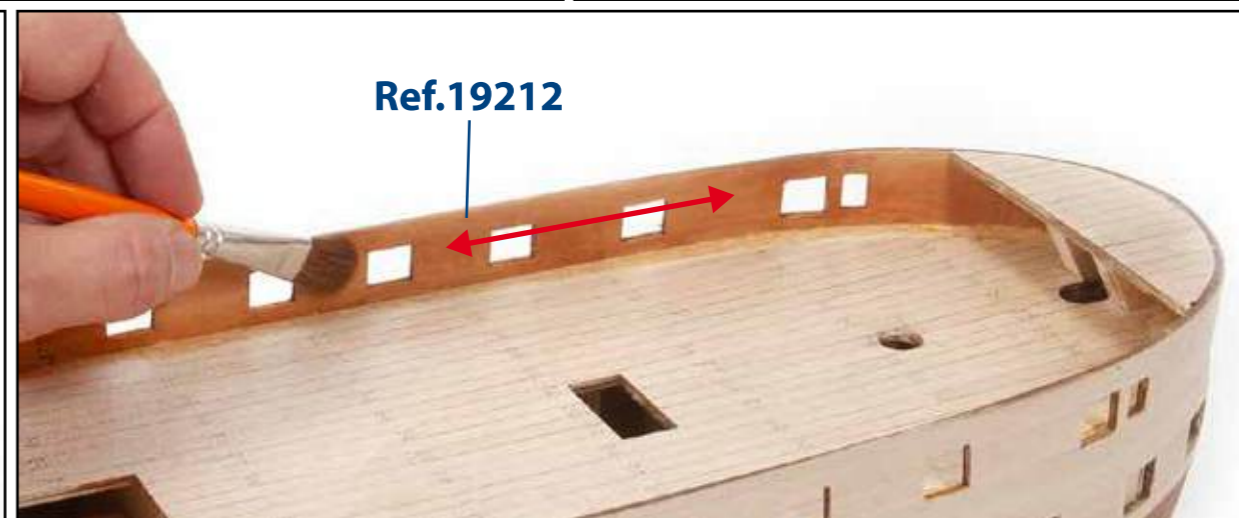
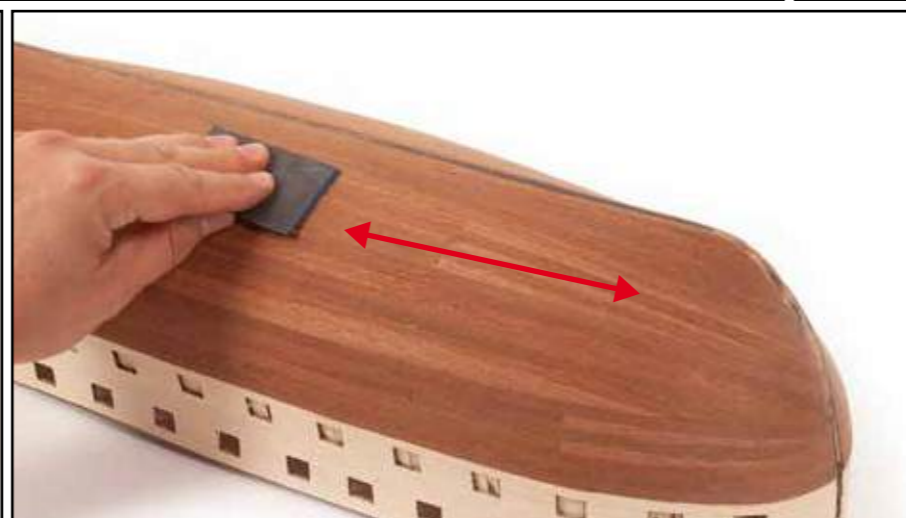
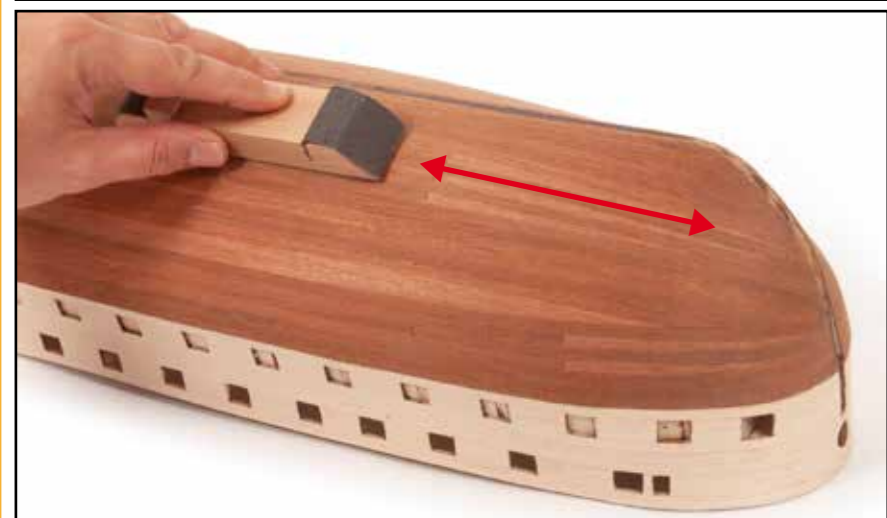

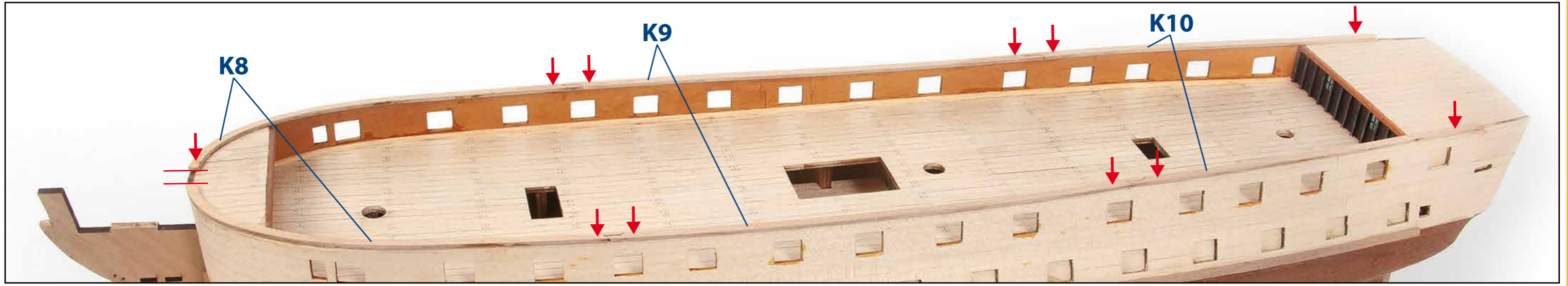
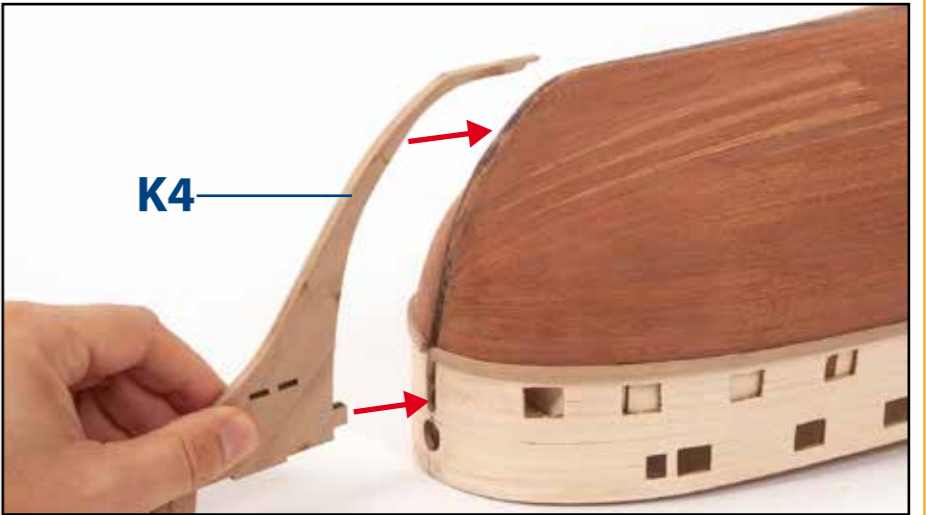
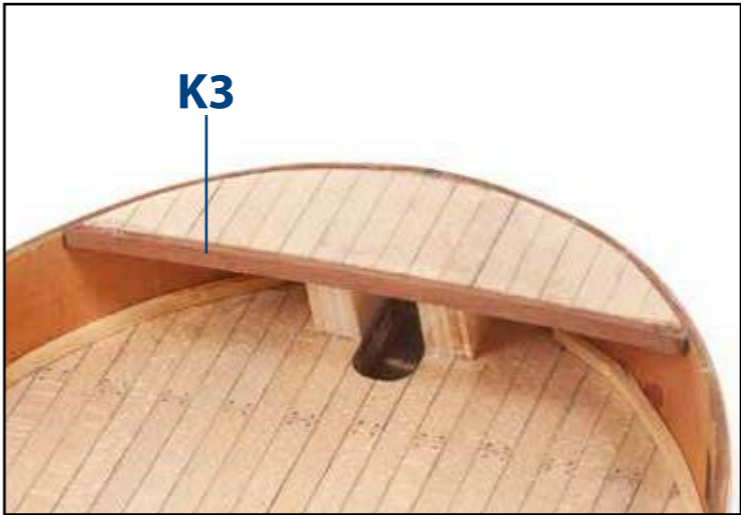
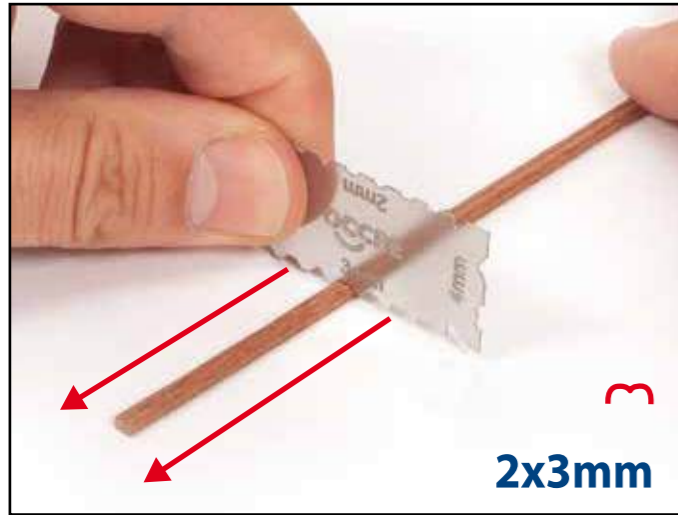
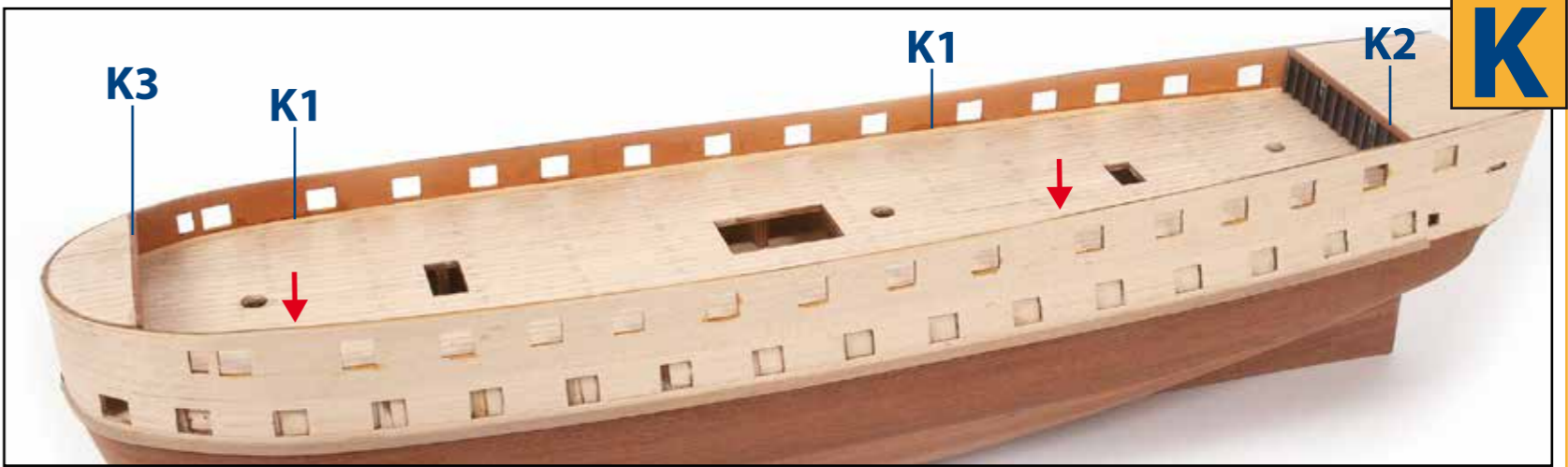
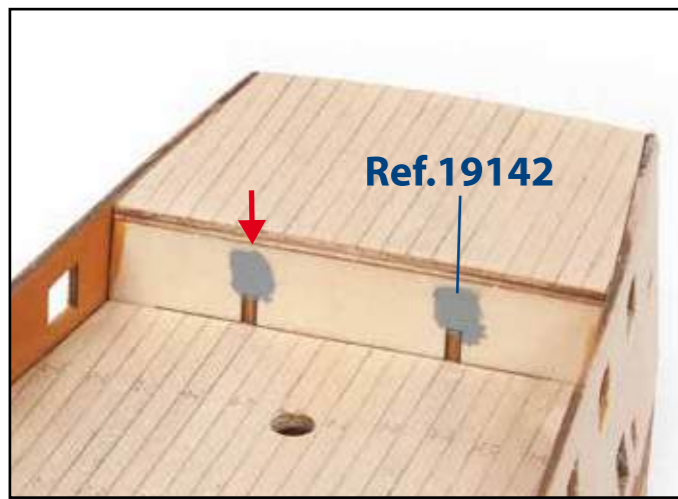

**L**

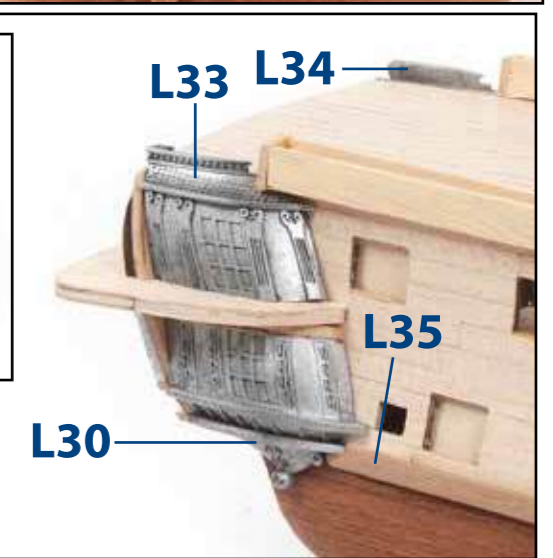
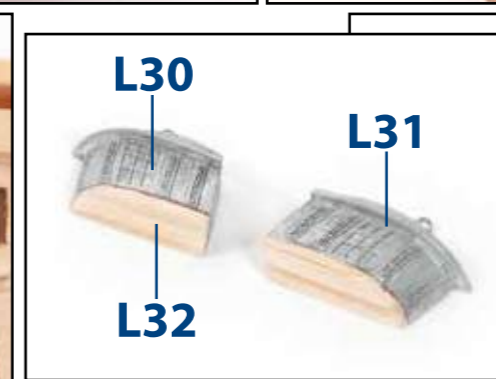
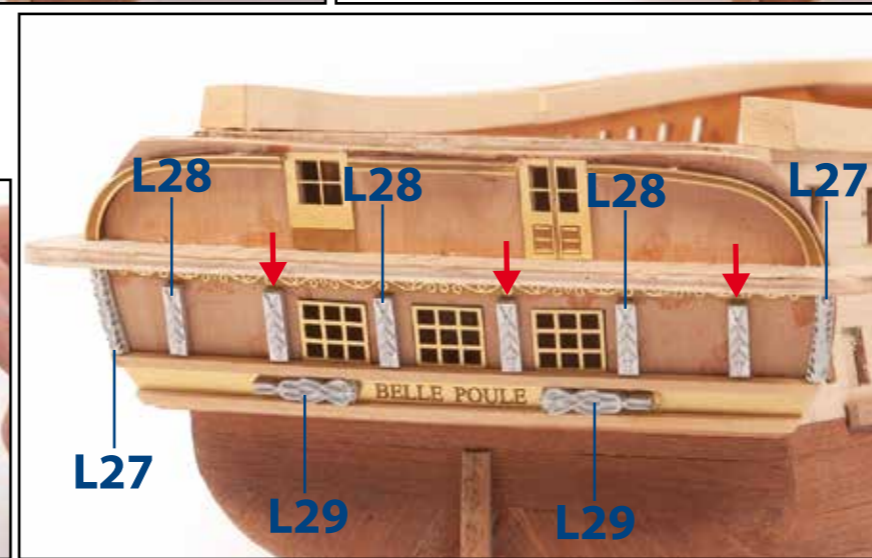
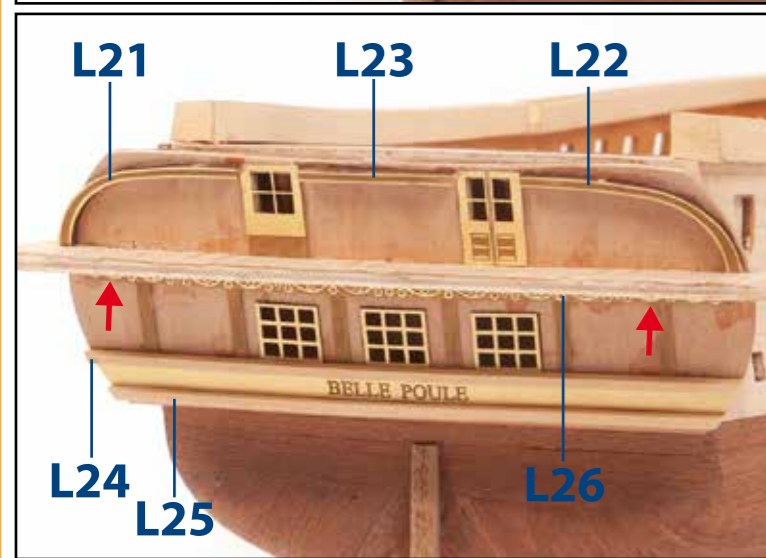
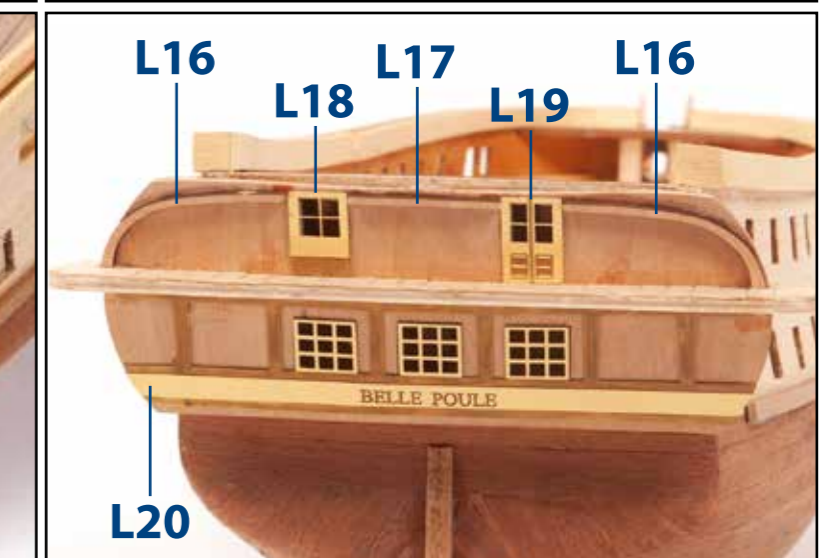
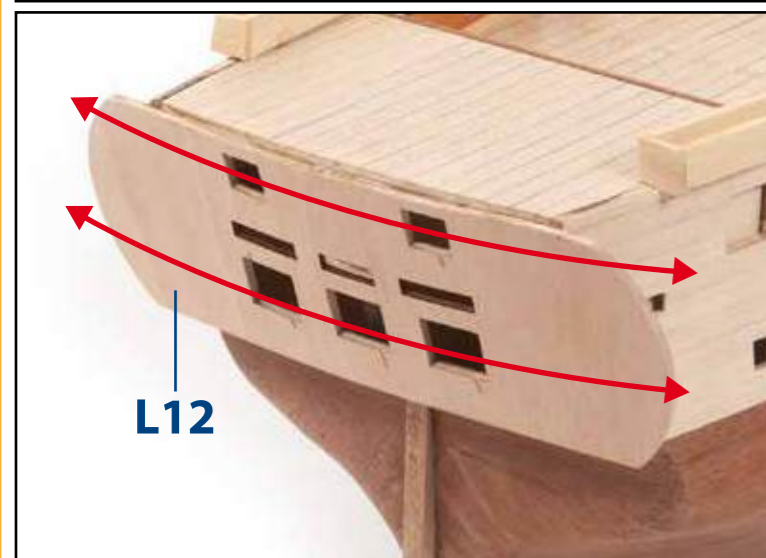
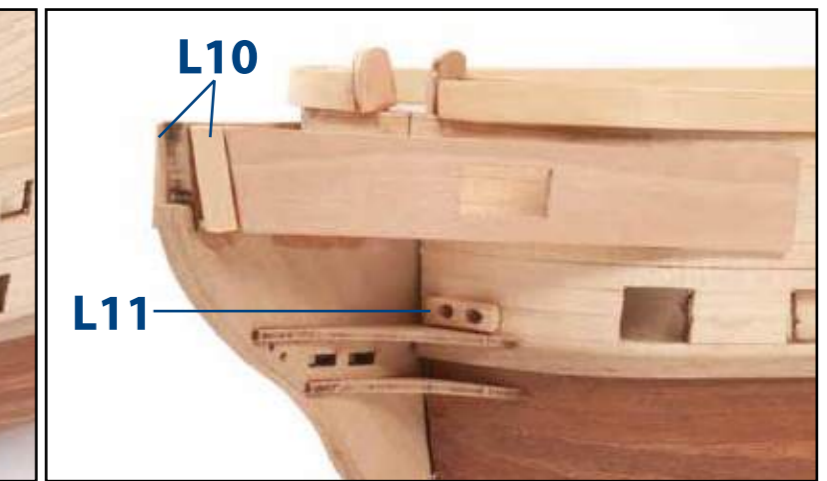
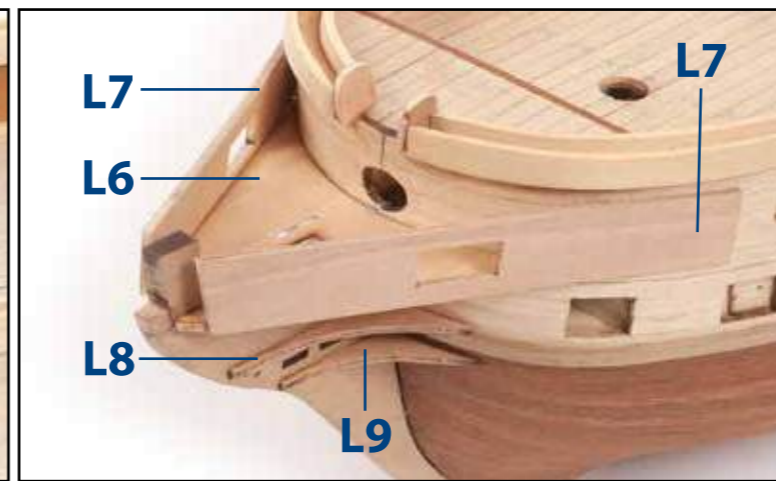
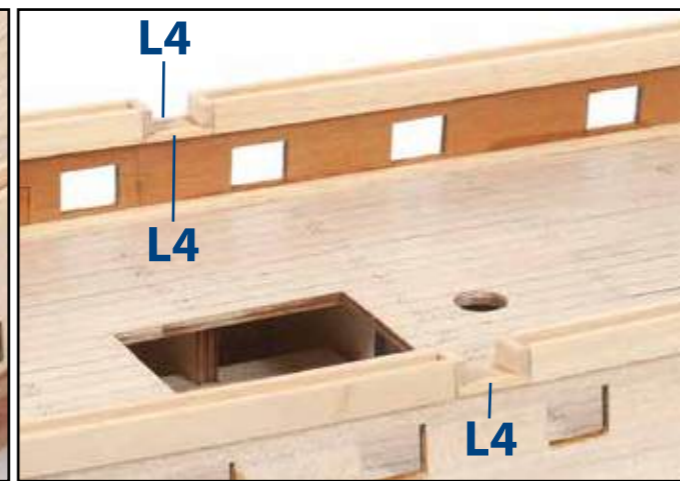
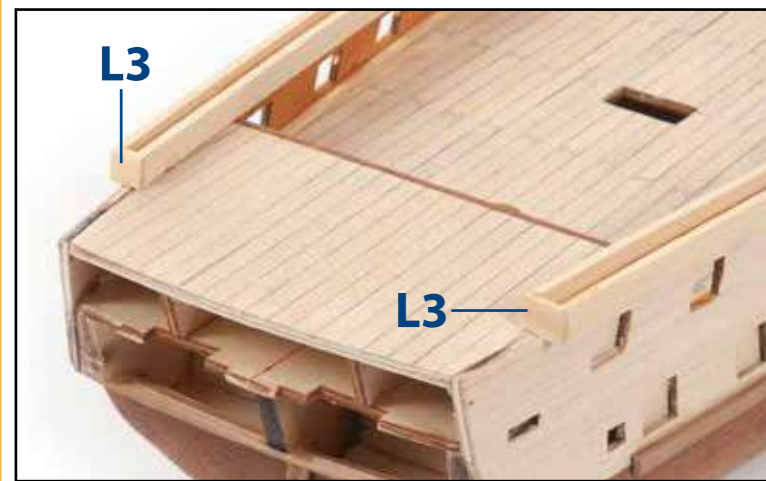
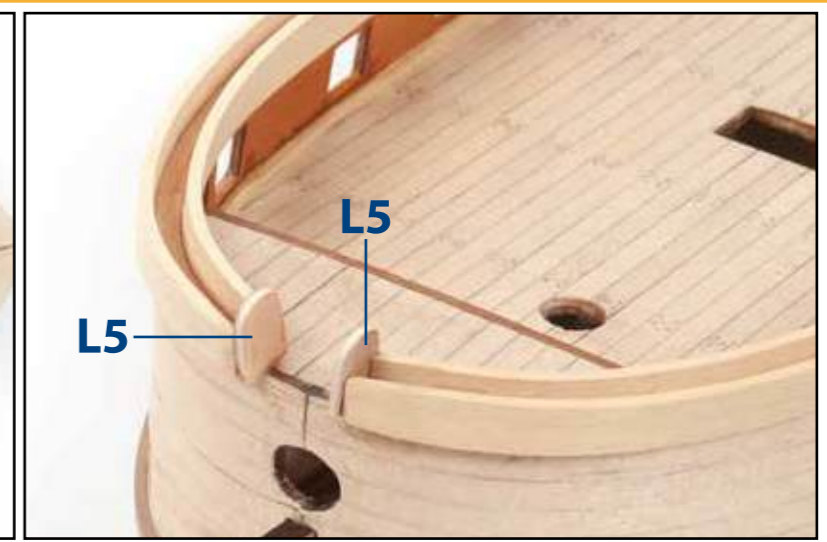
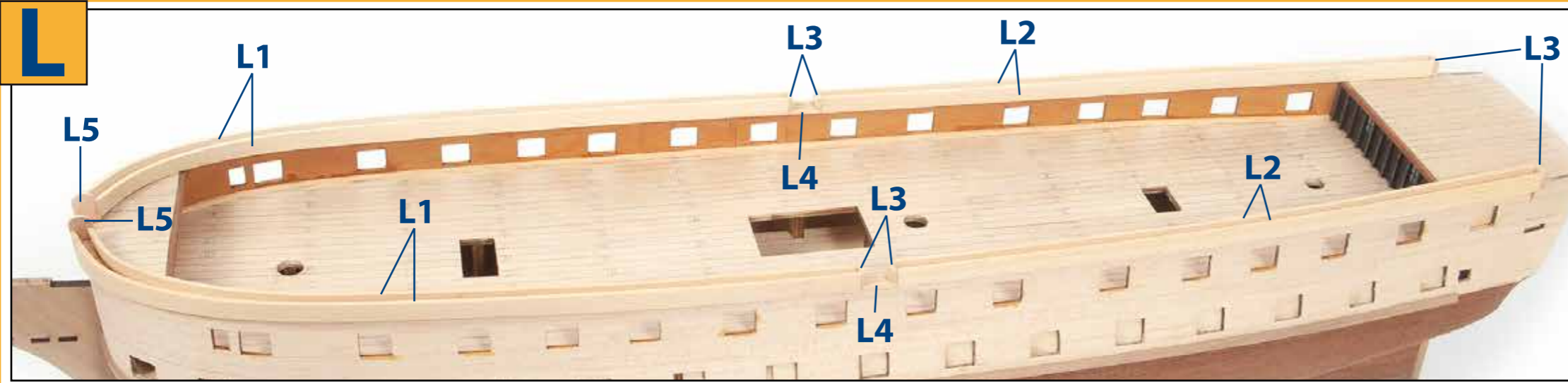

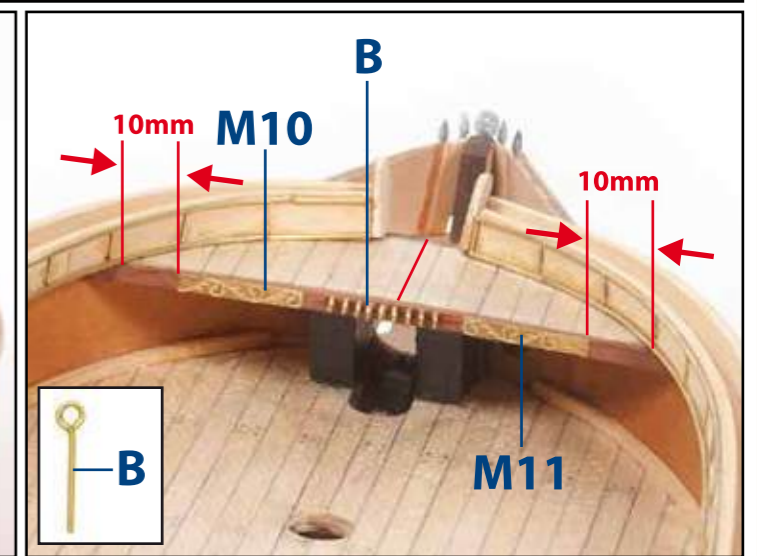
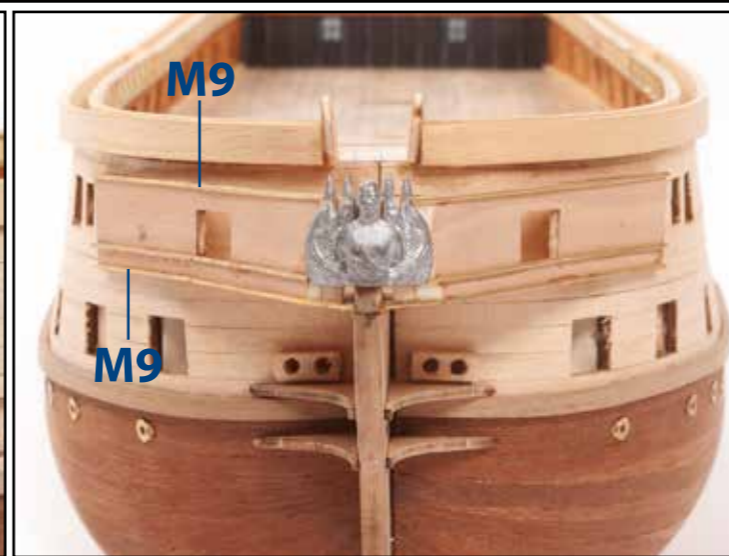
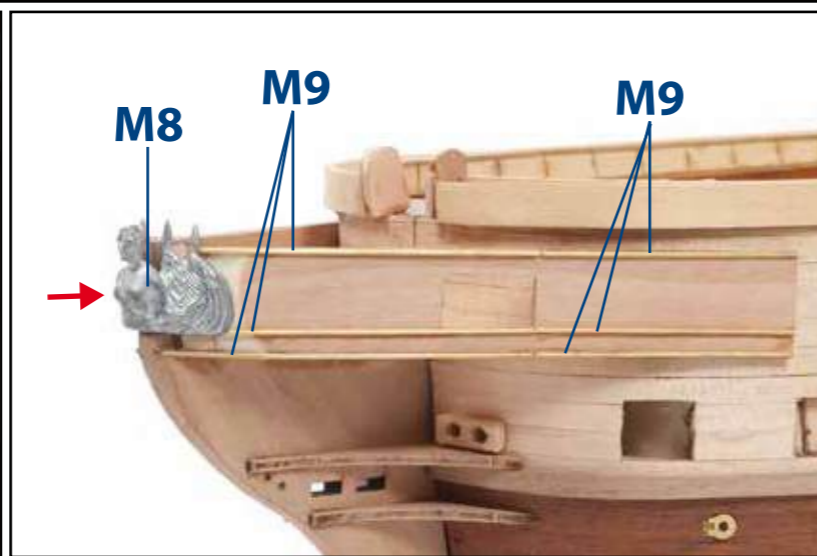
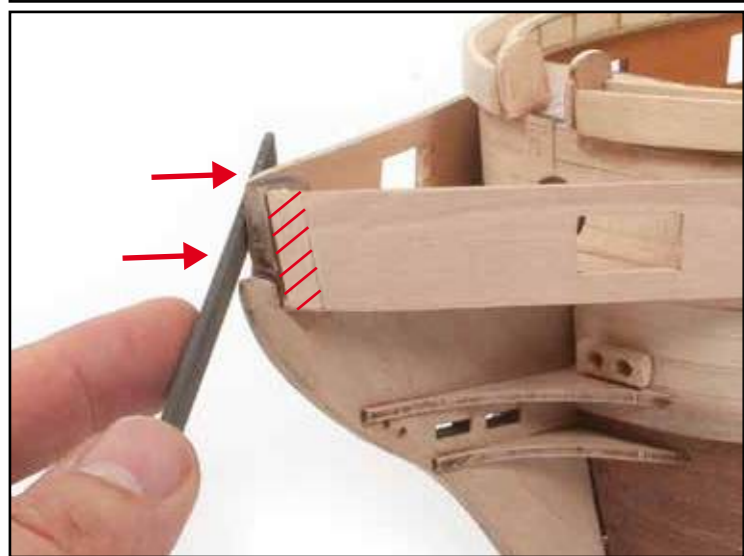
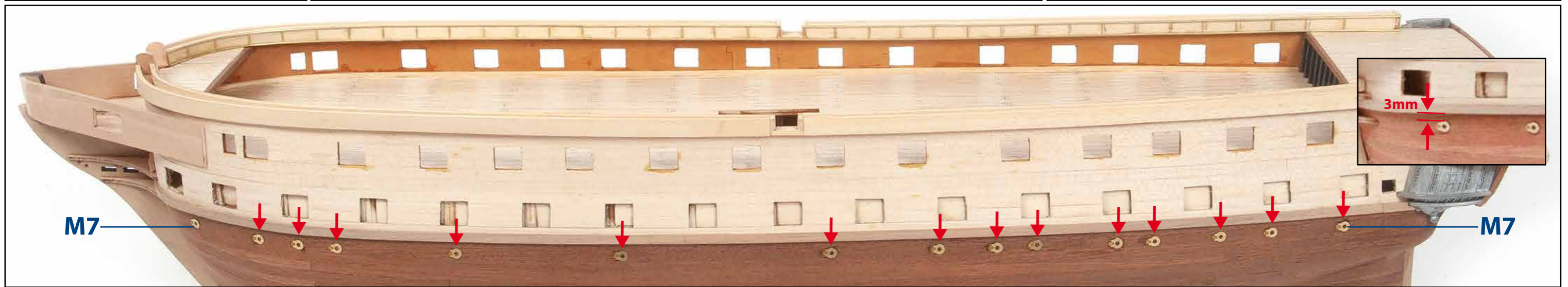
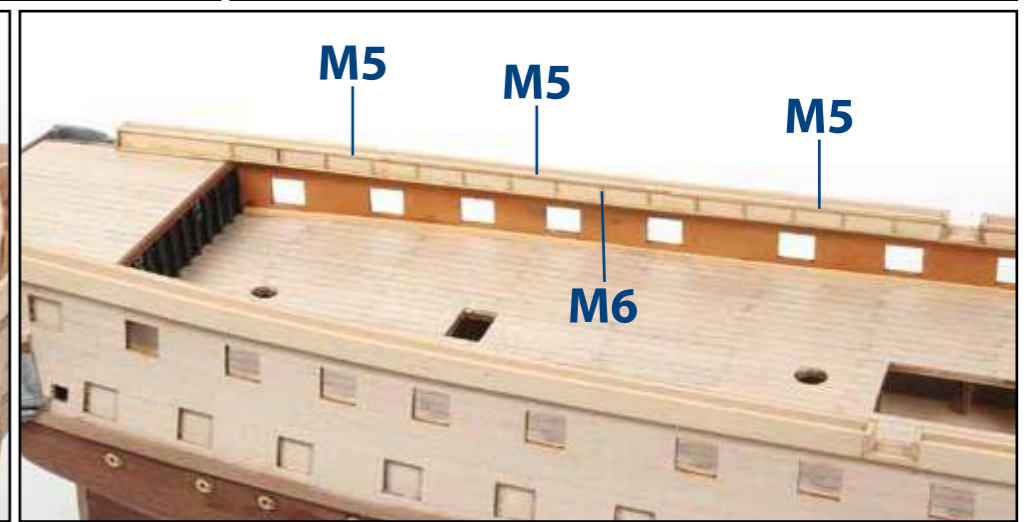
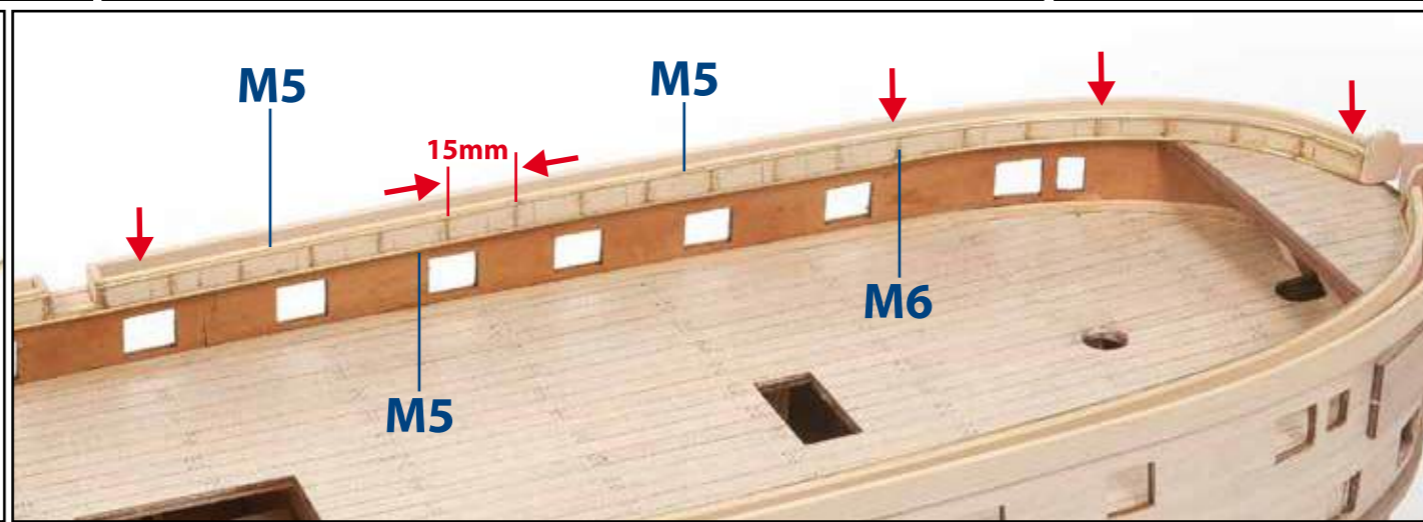
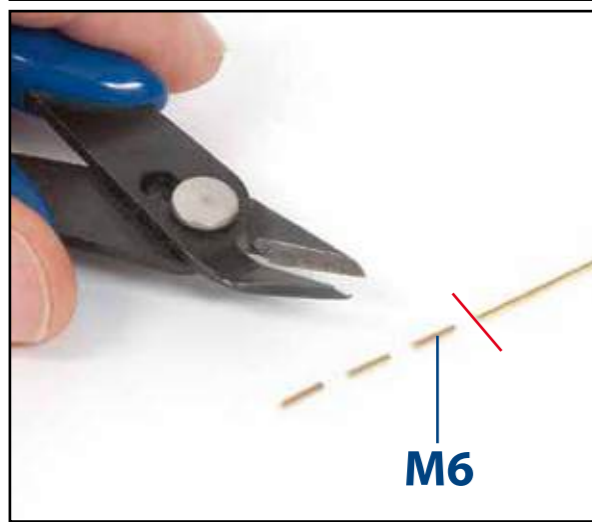
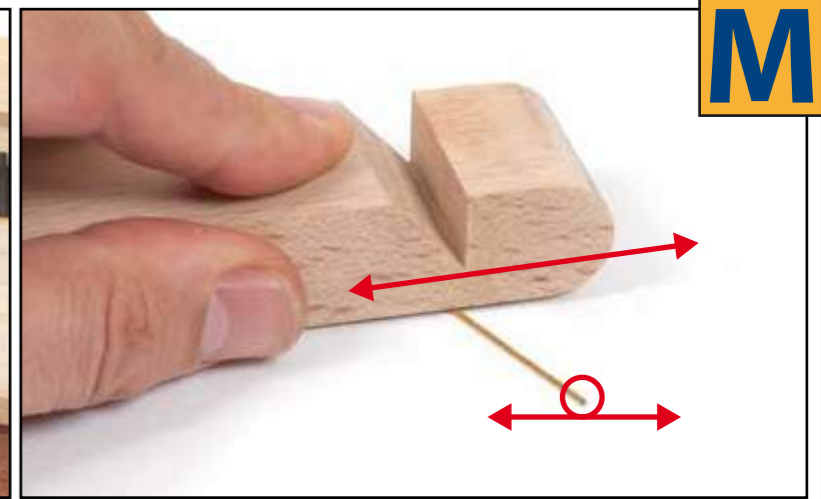
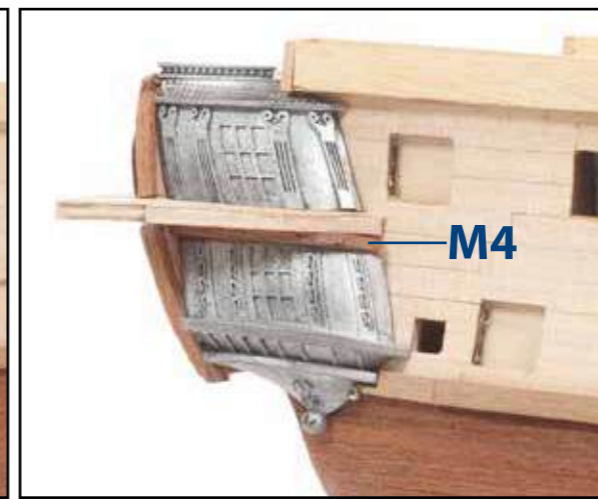
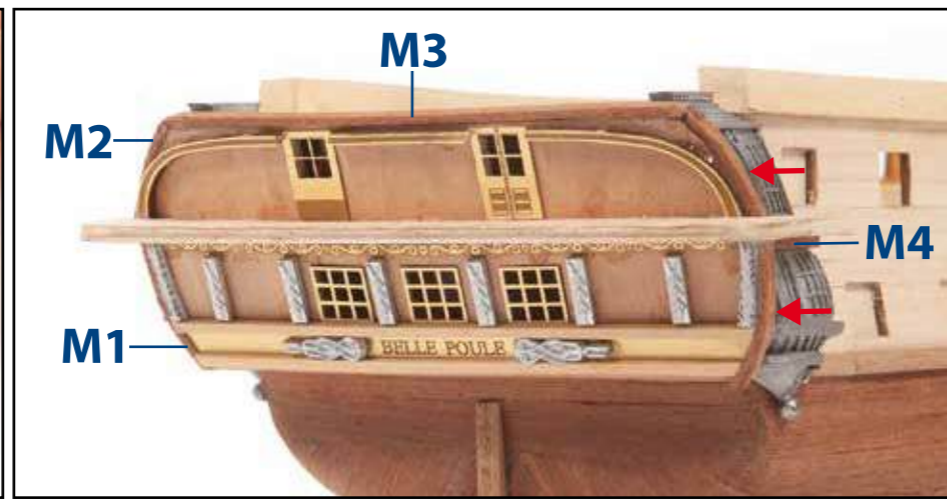
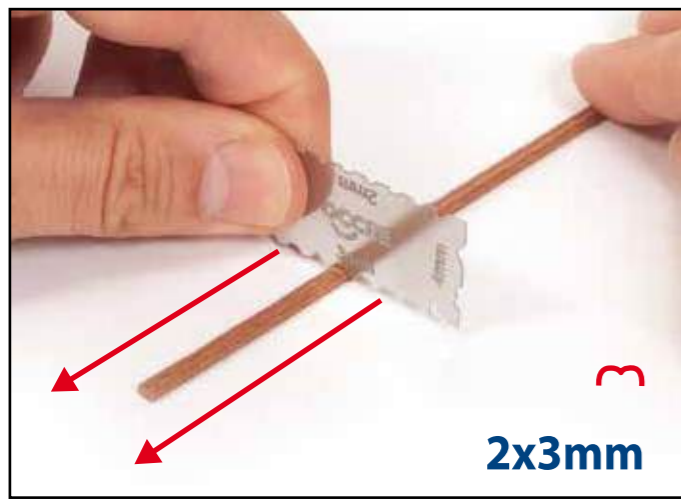

**N**

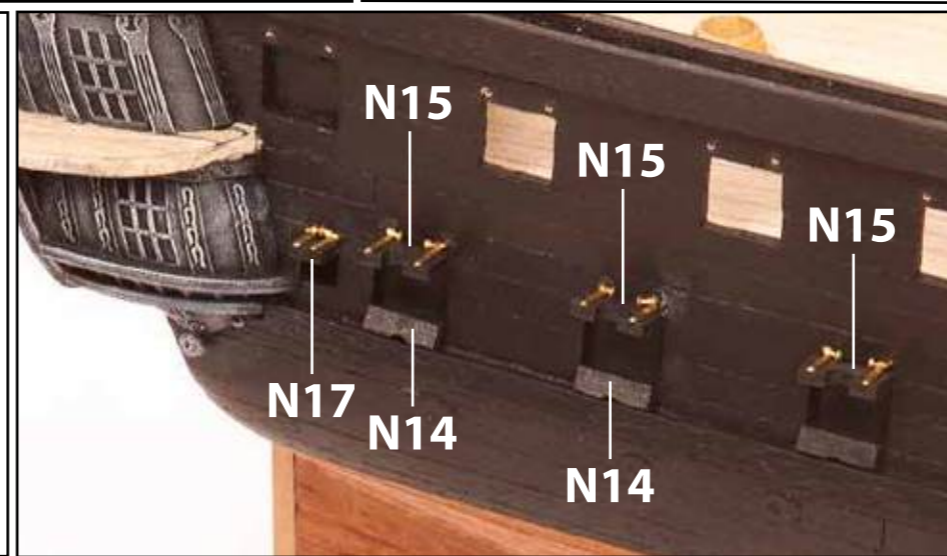
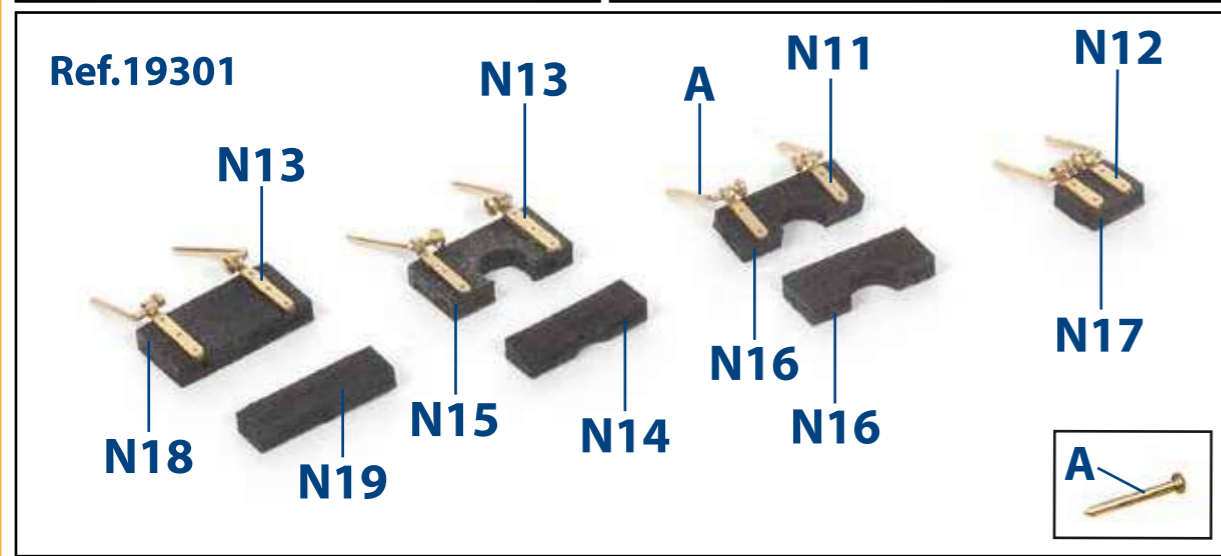
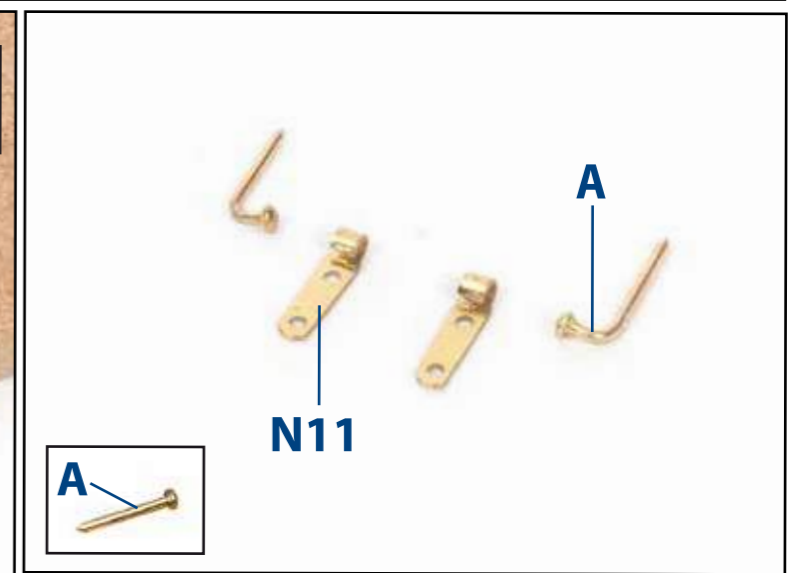
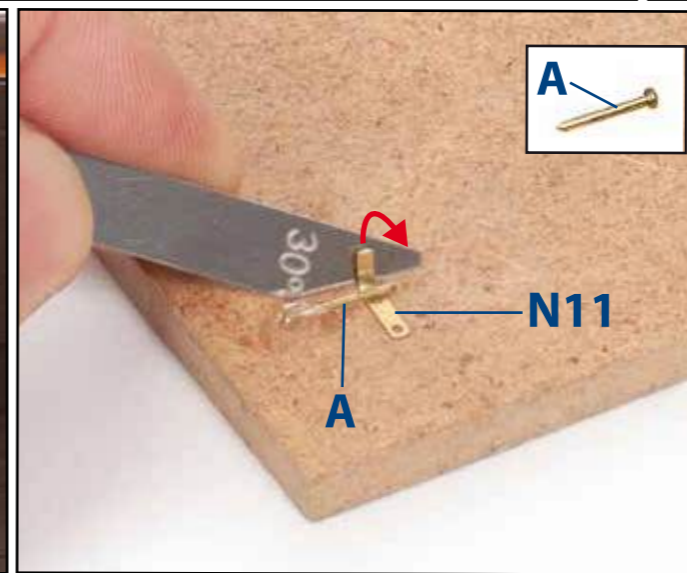
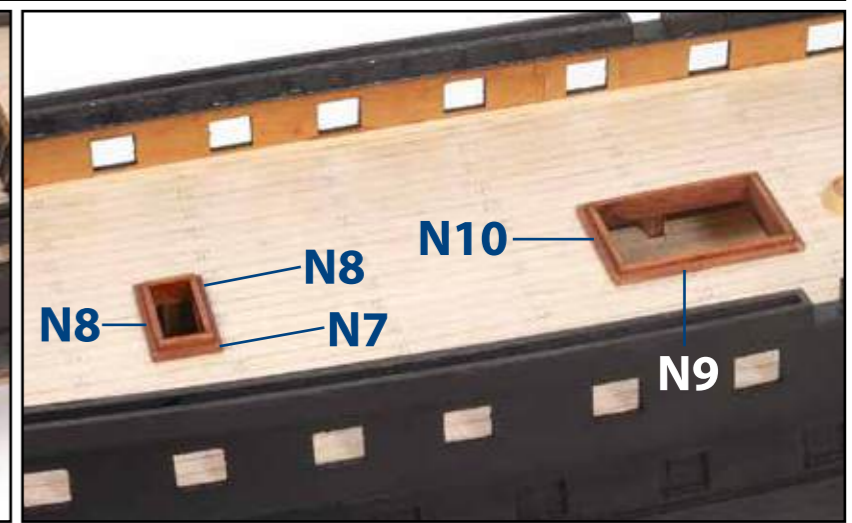
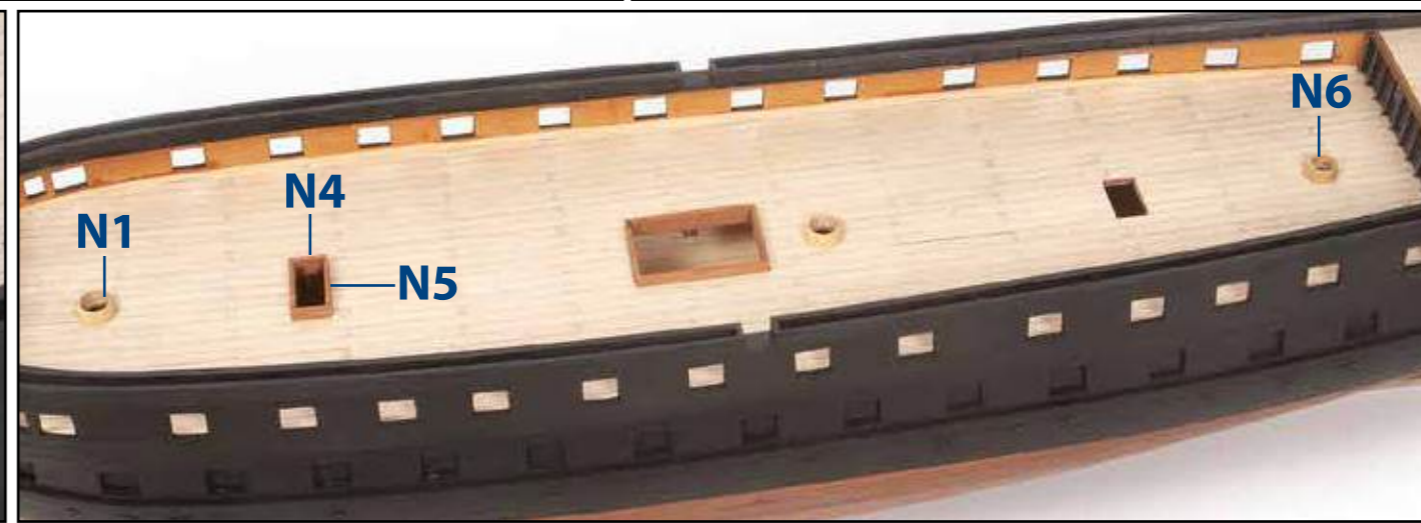
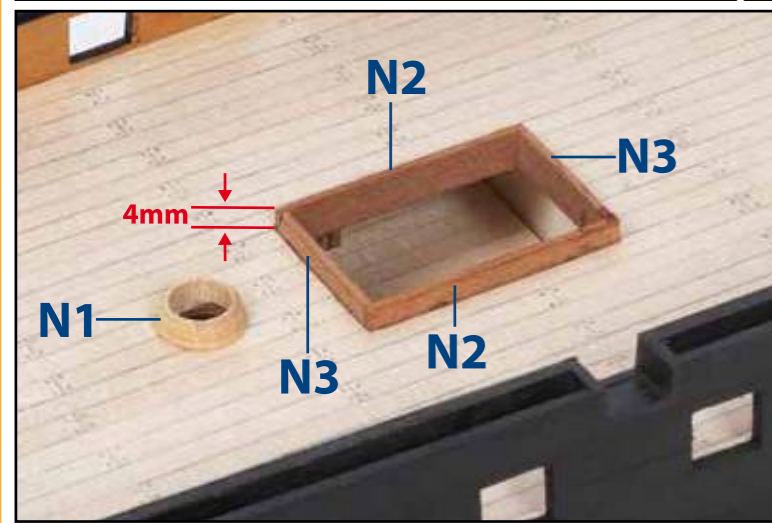
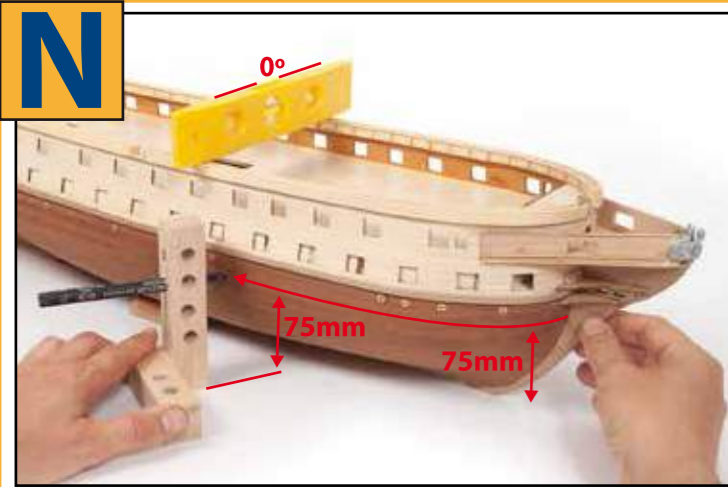

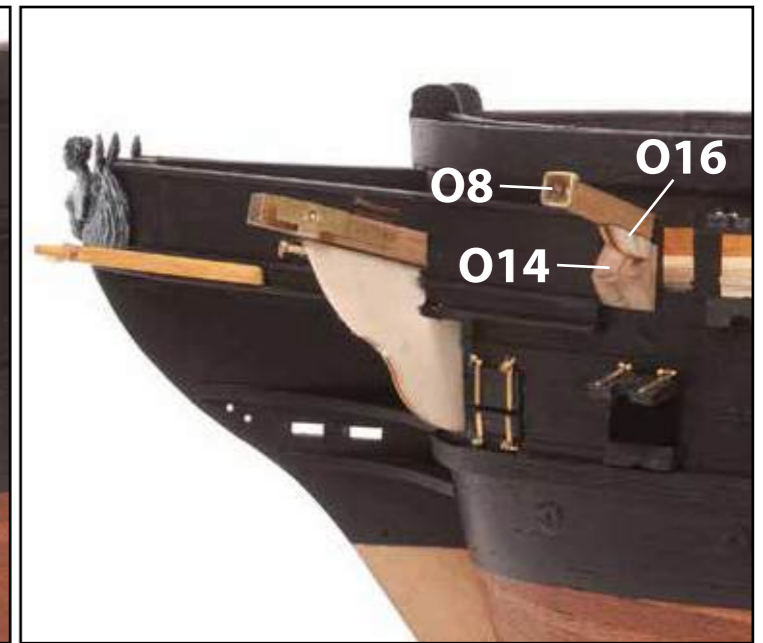
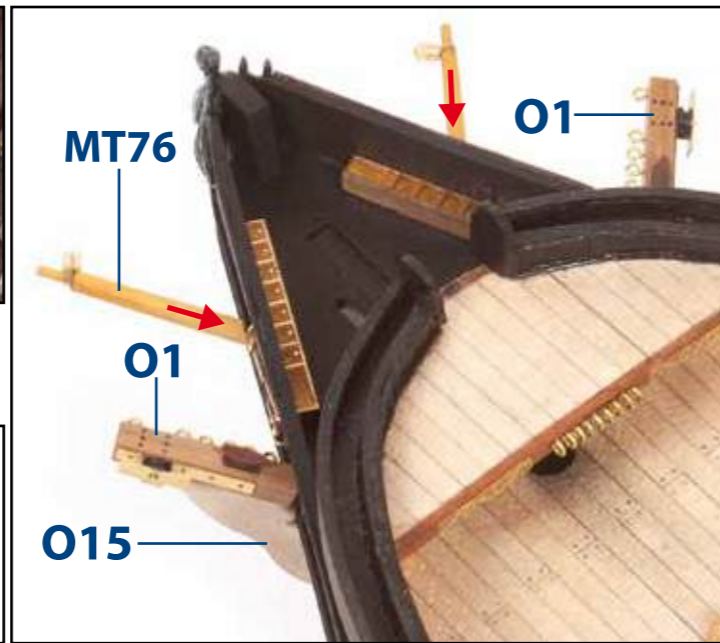
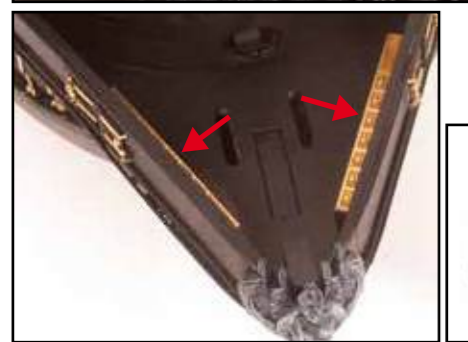
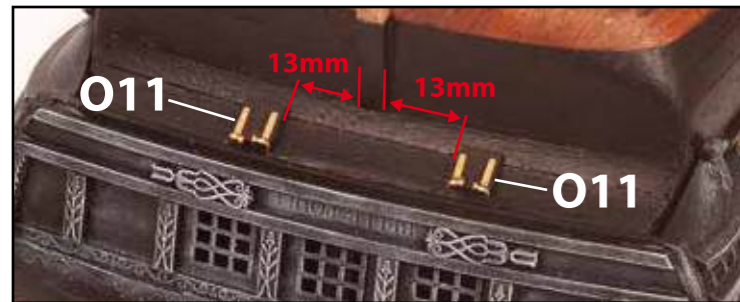
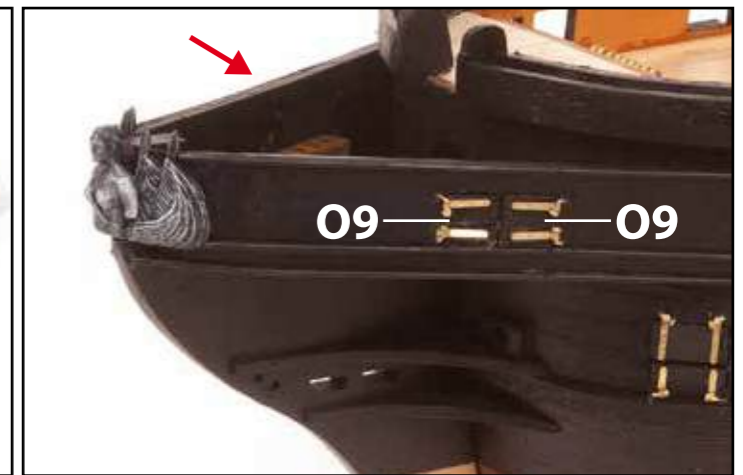
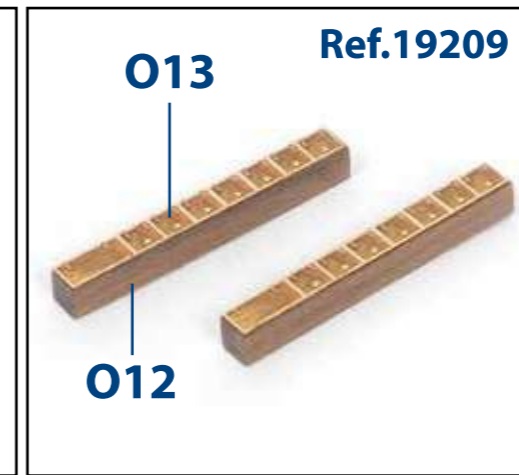
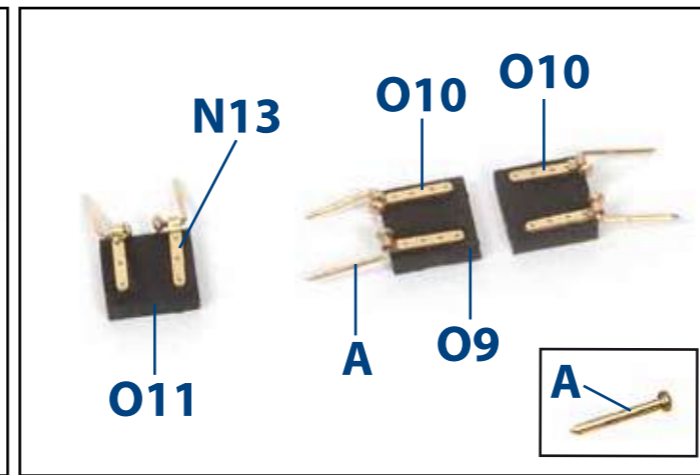
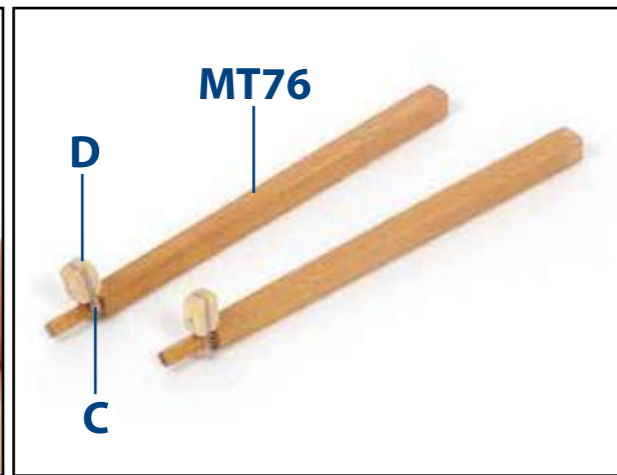
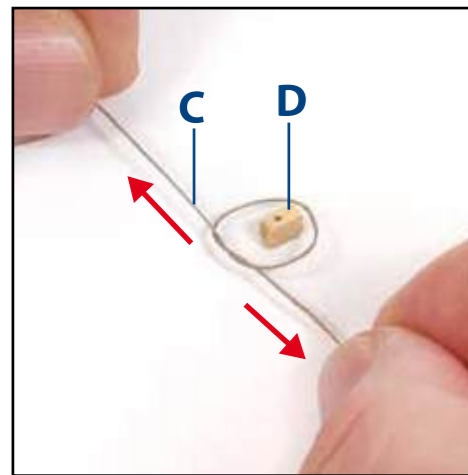
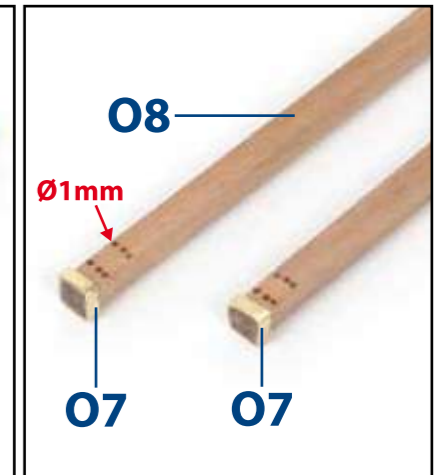
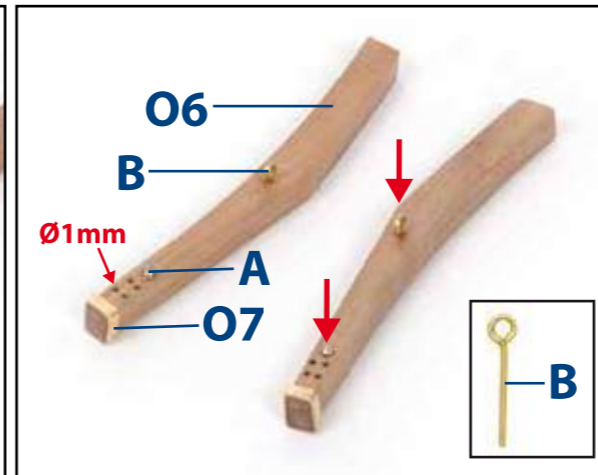
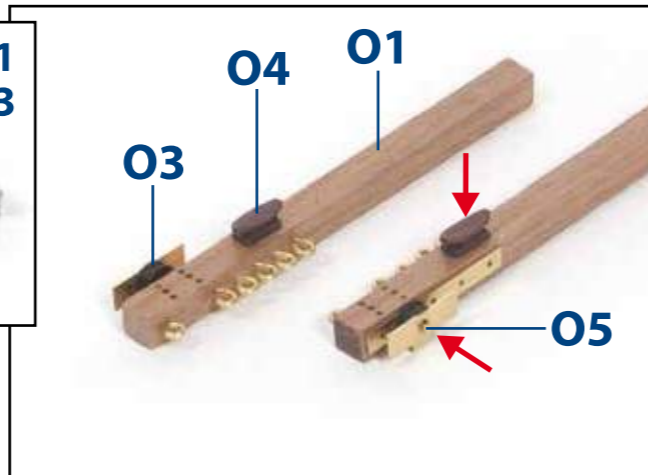
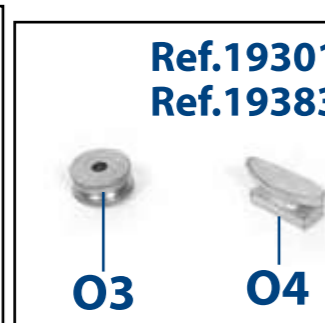
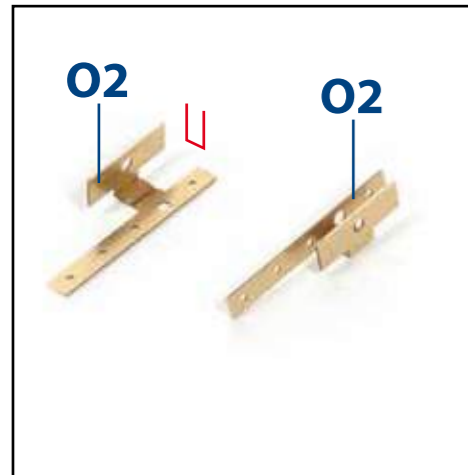
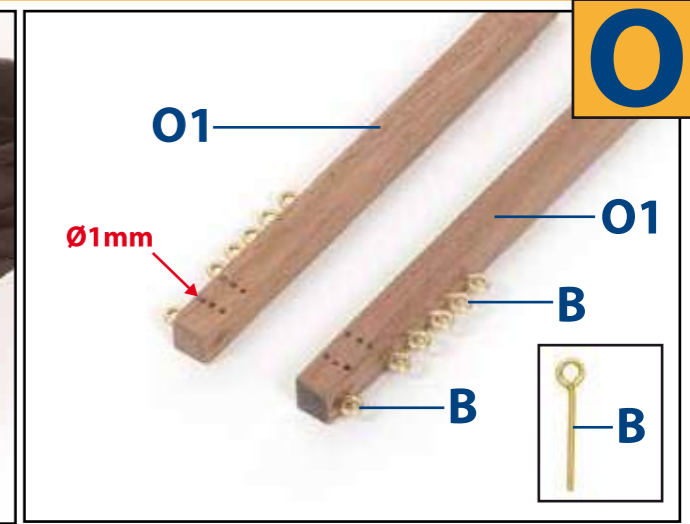



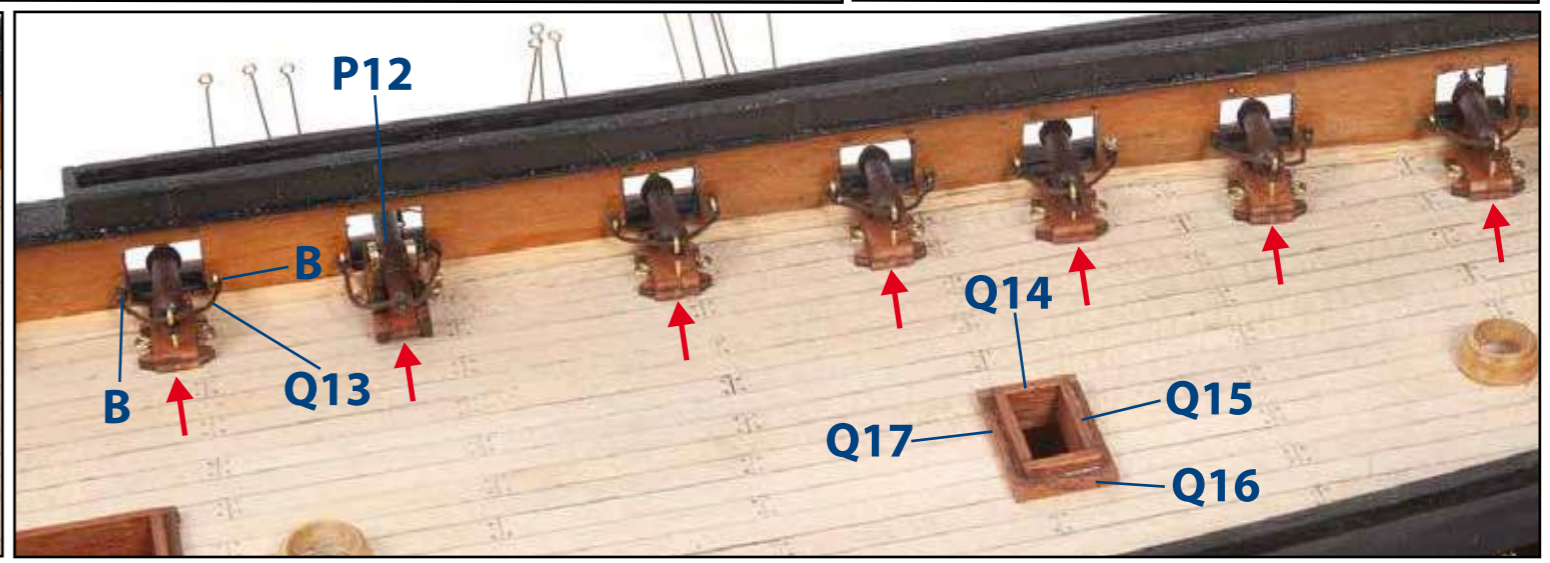
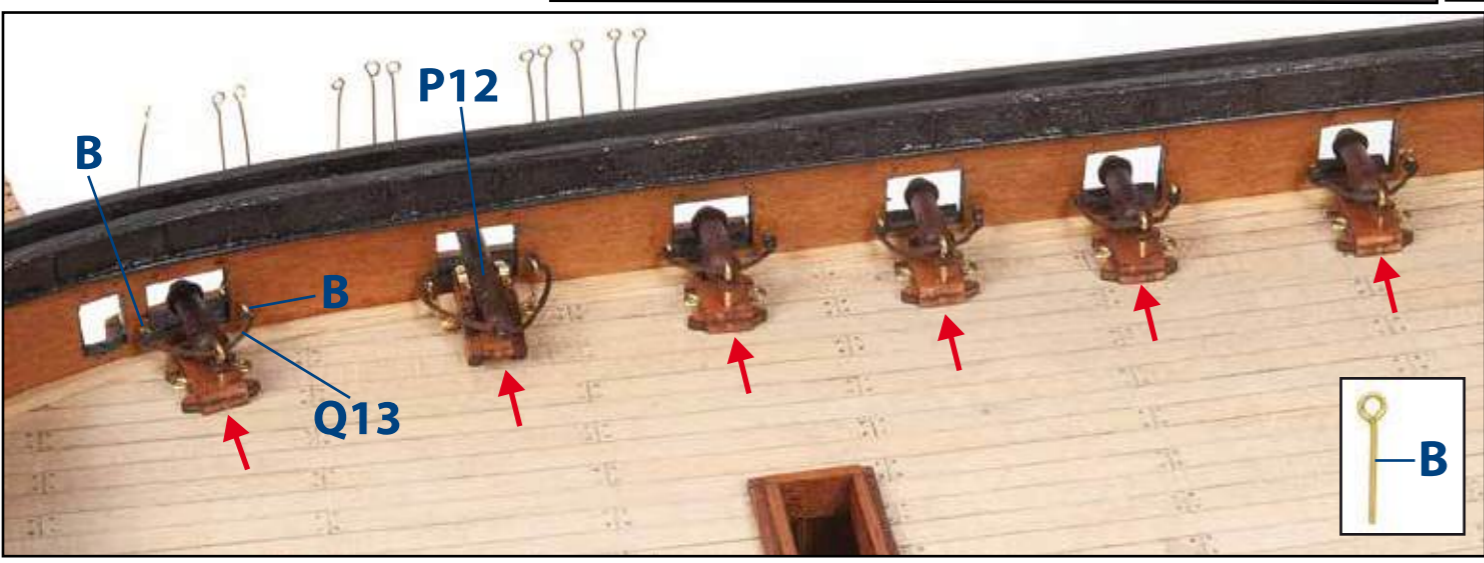
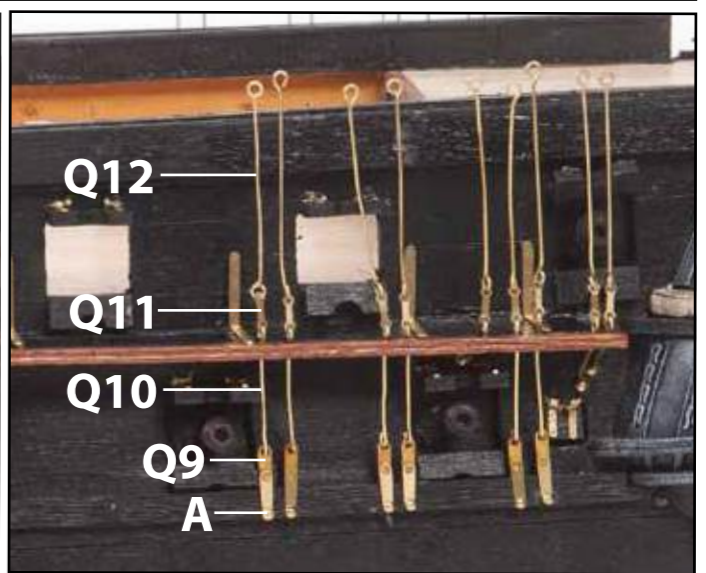
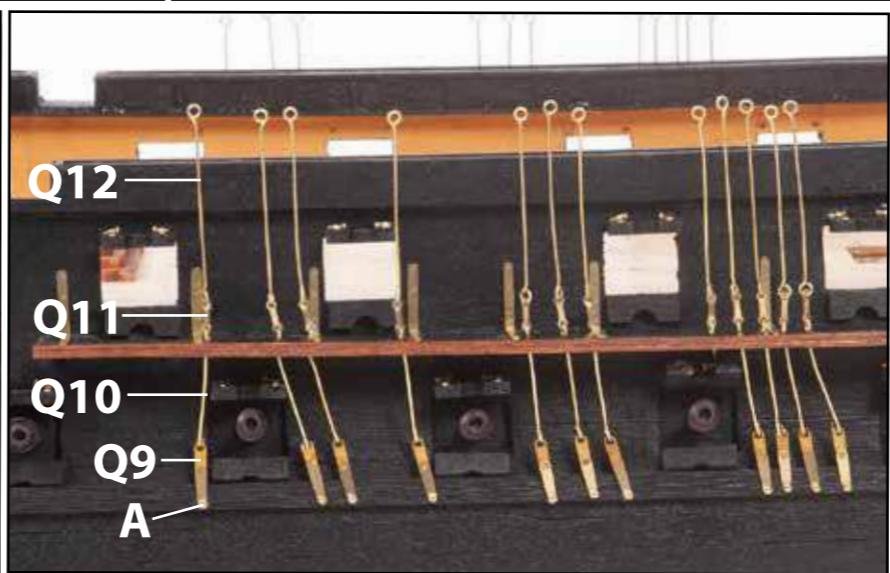
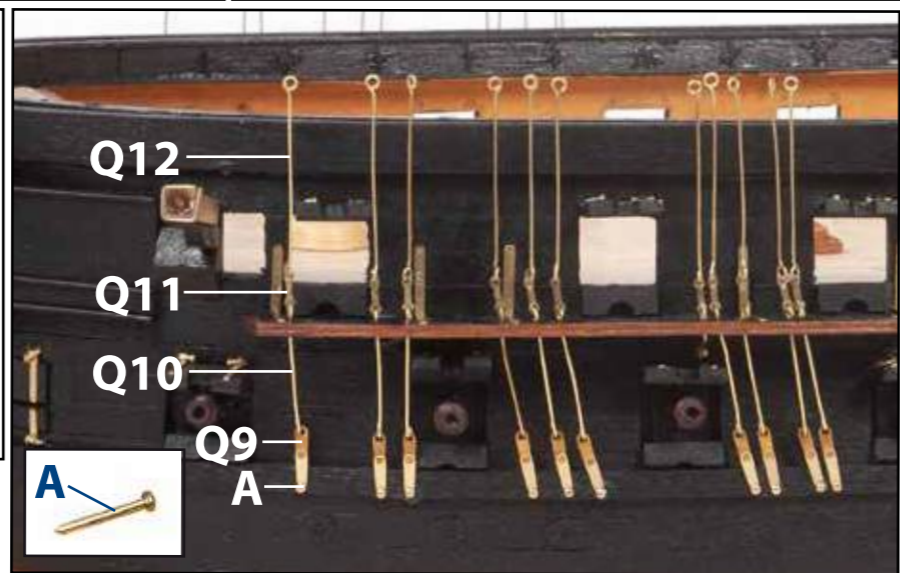
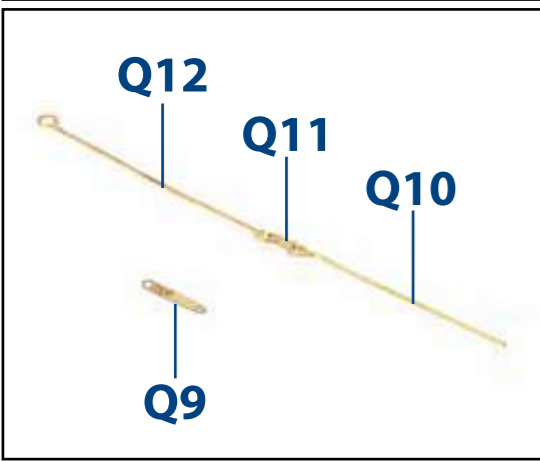
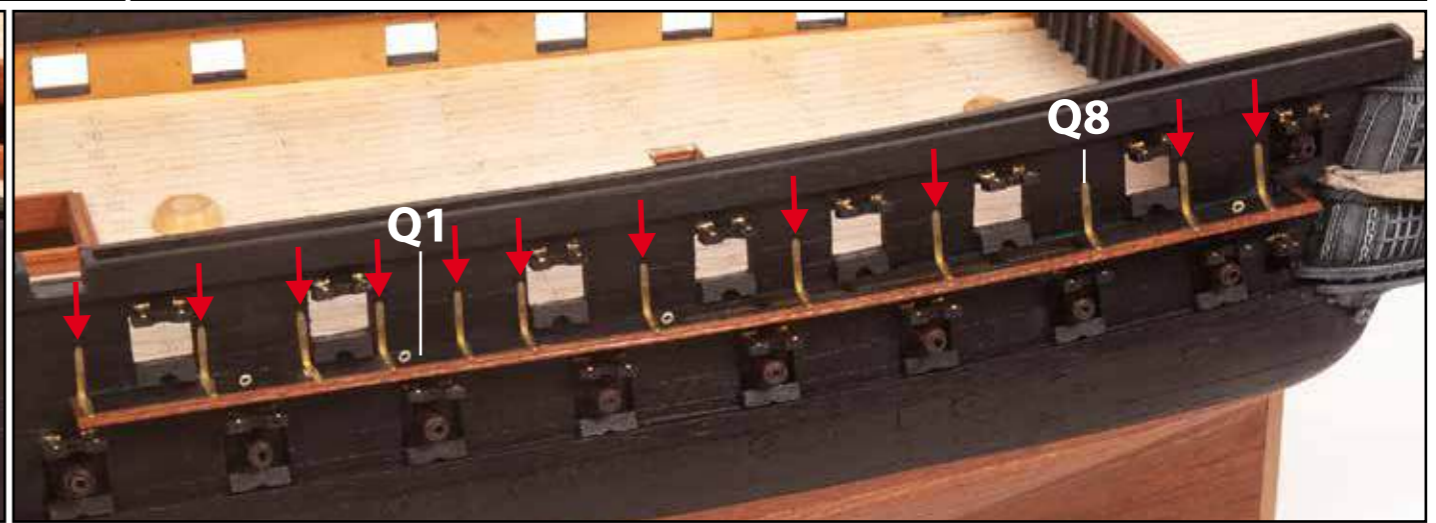
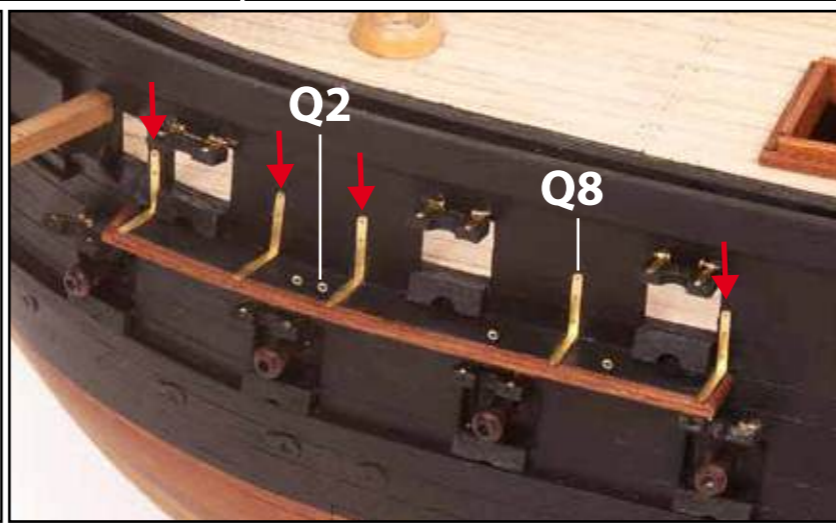
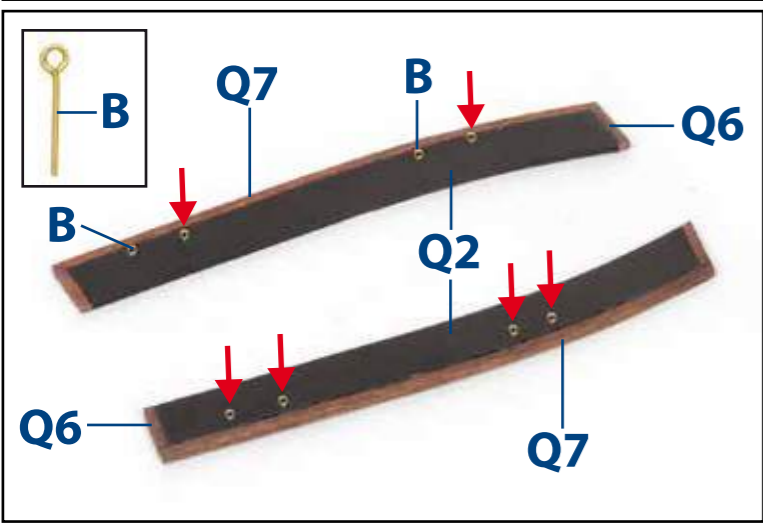
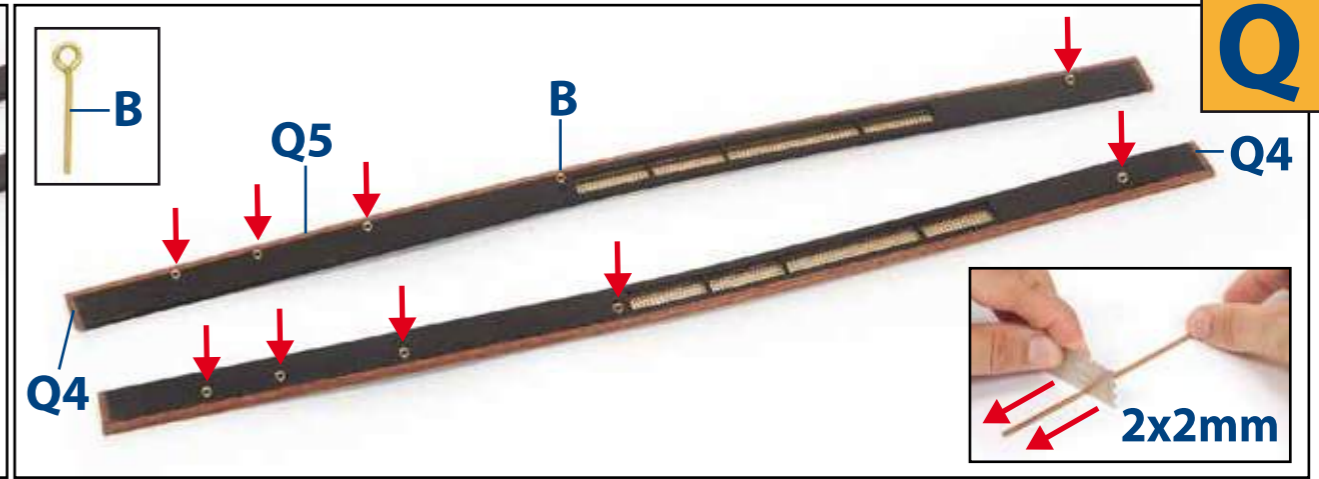
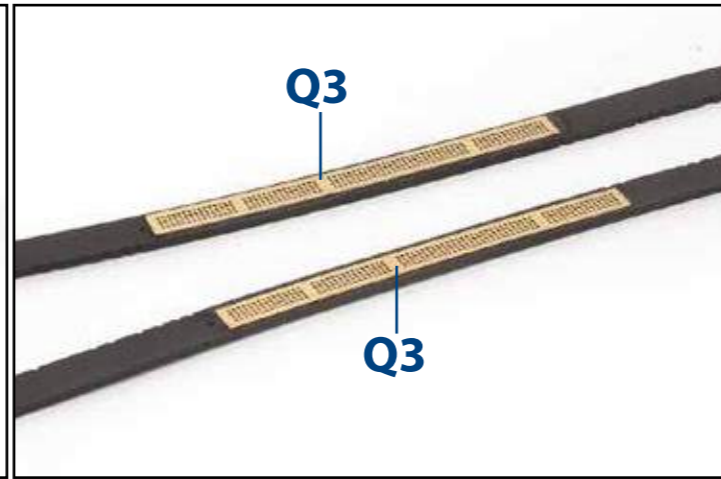
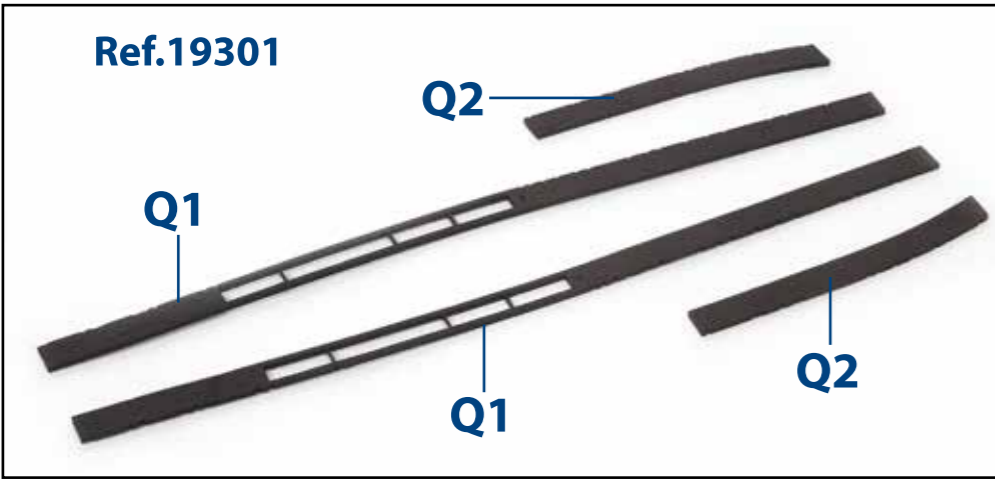

**R**

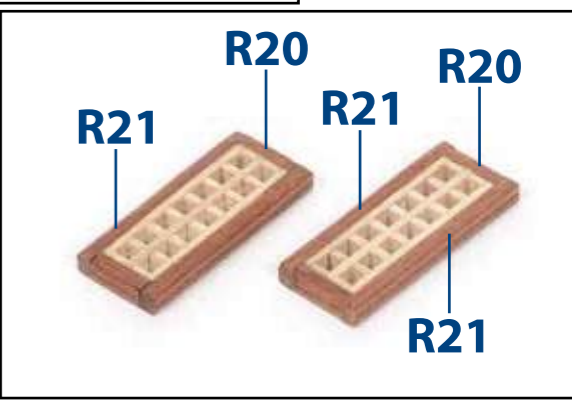
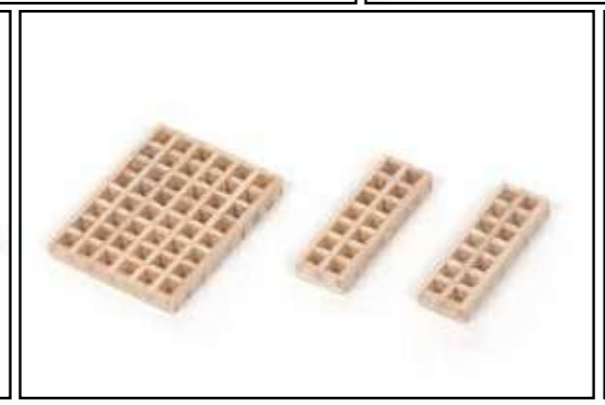
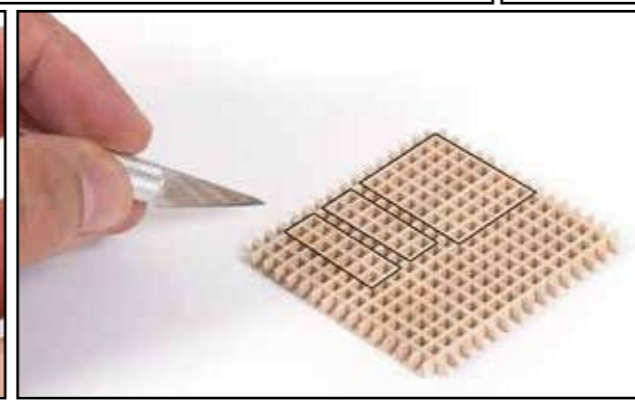
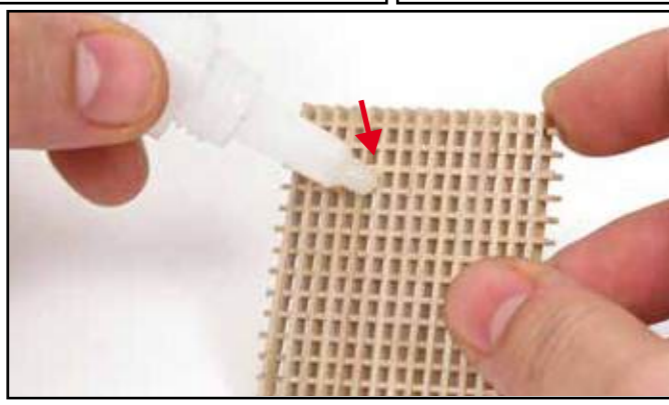
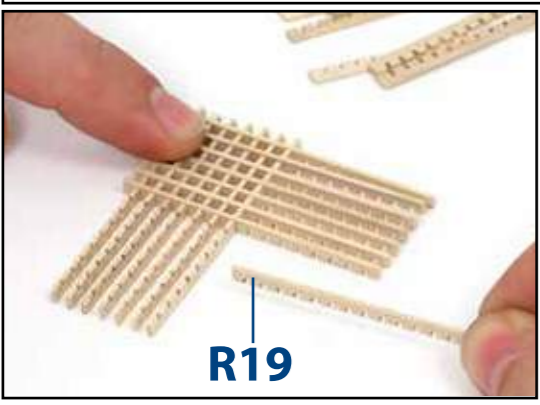
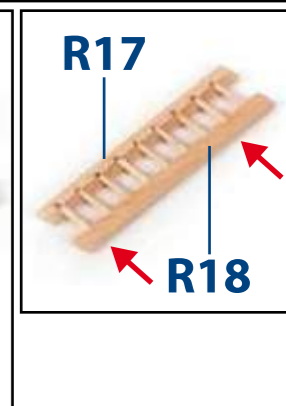
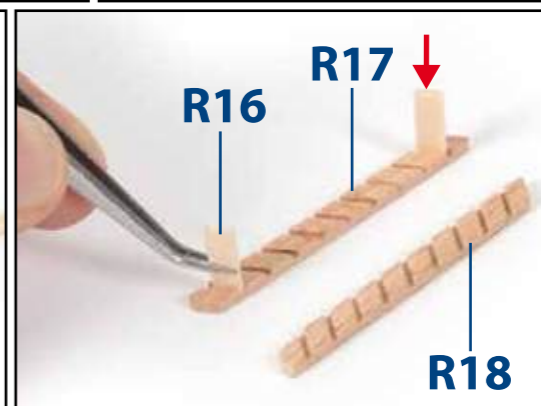
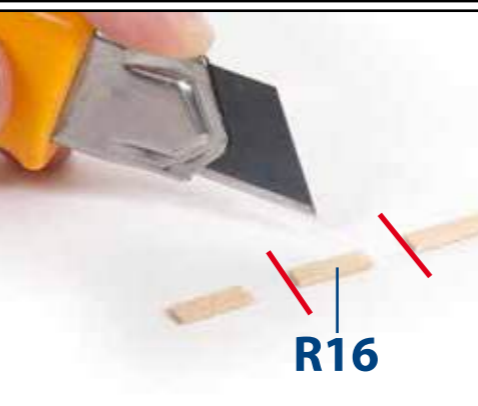
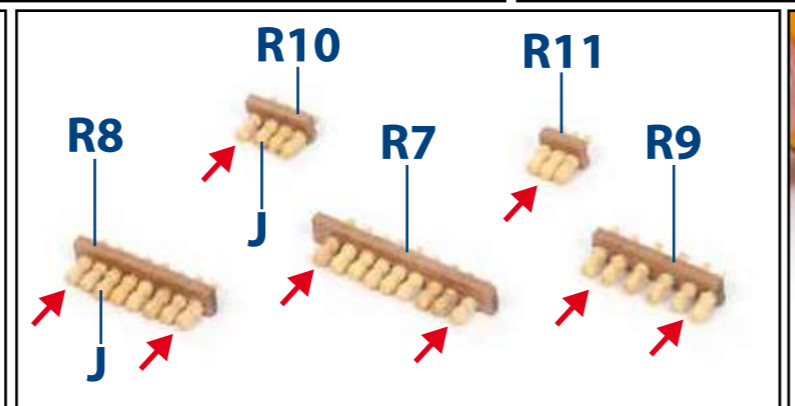
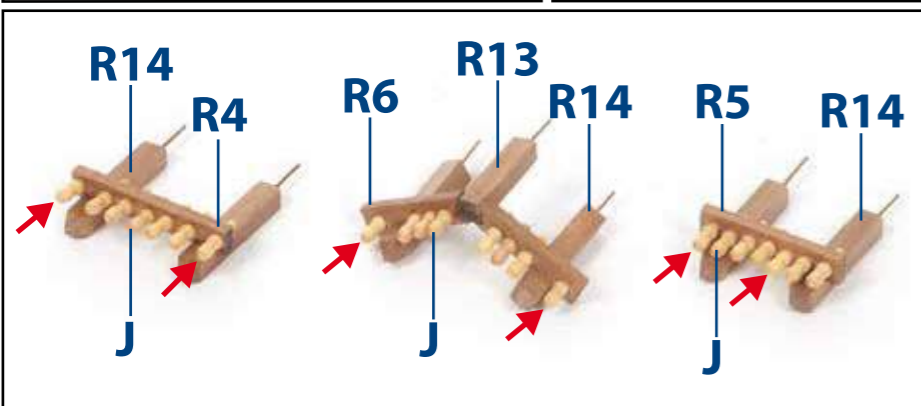
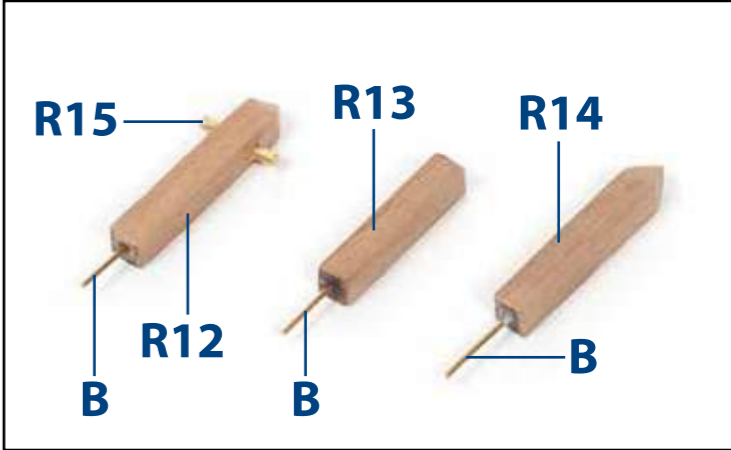
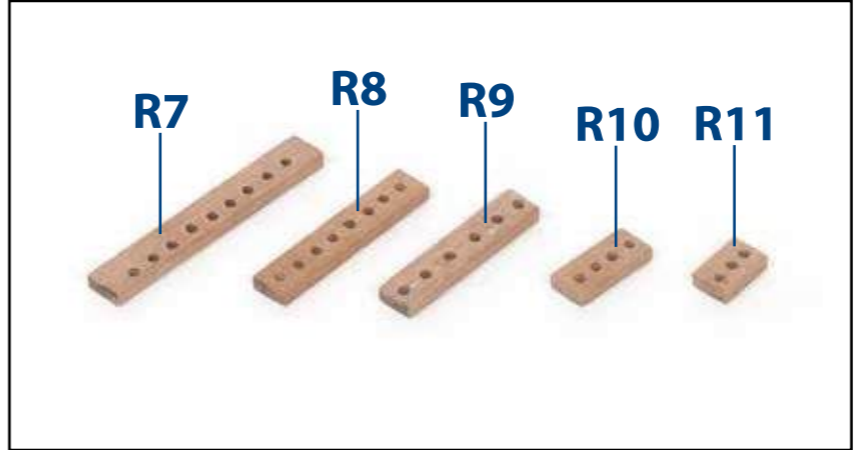
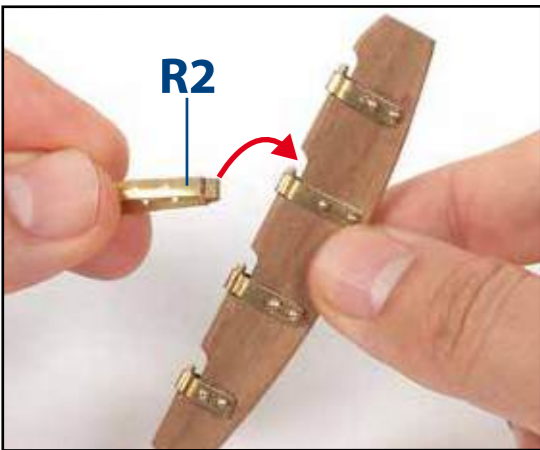
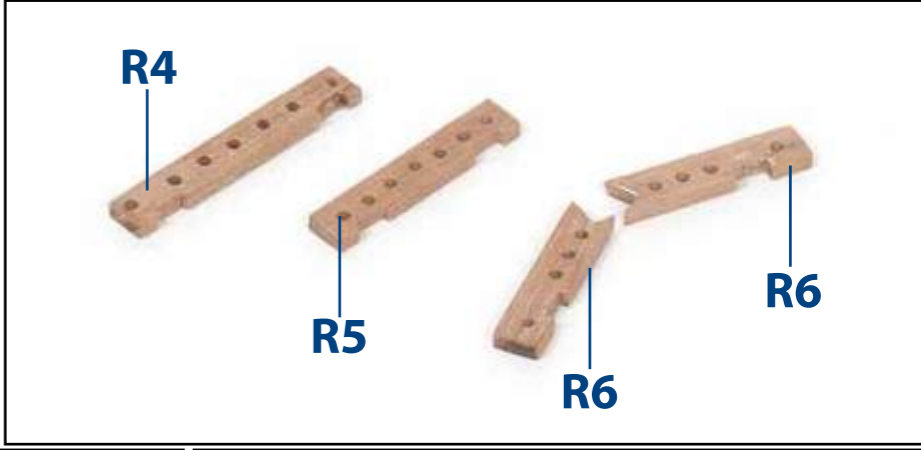
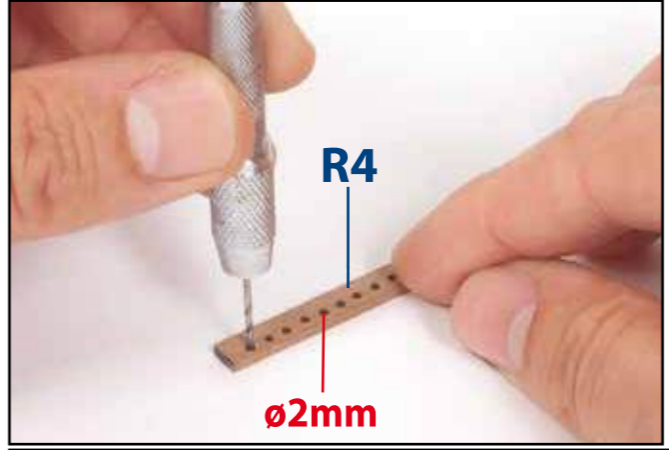
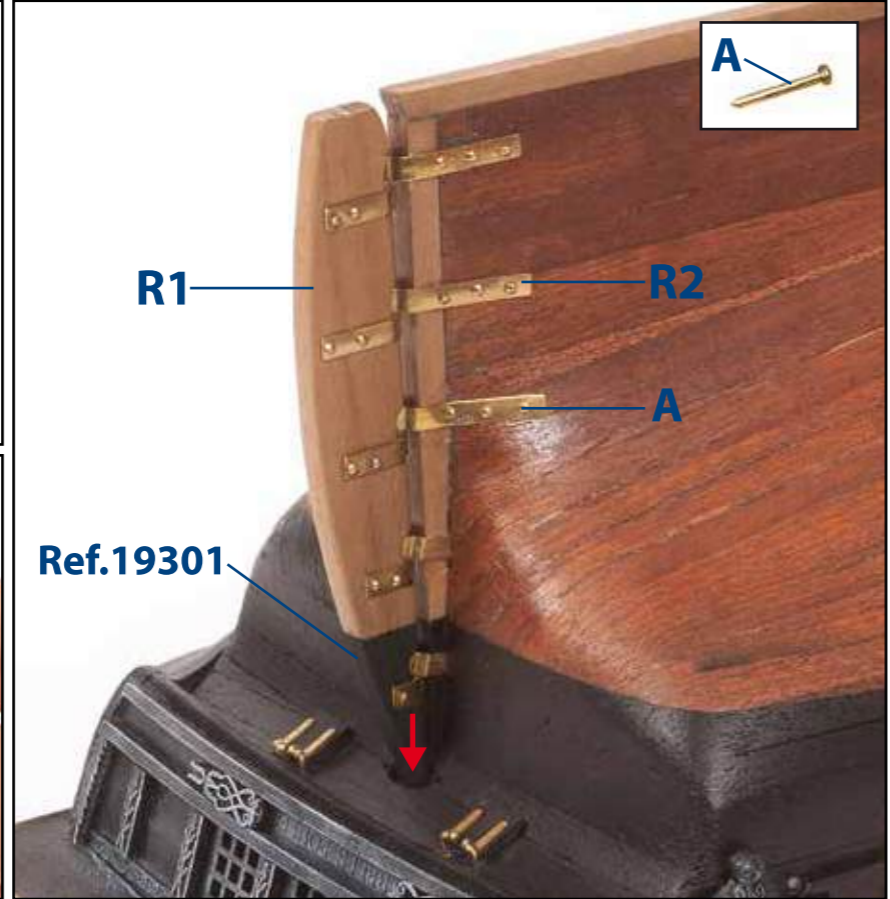
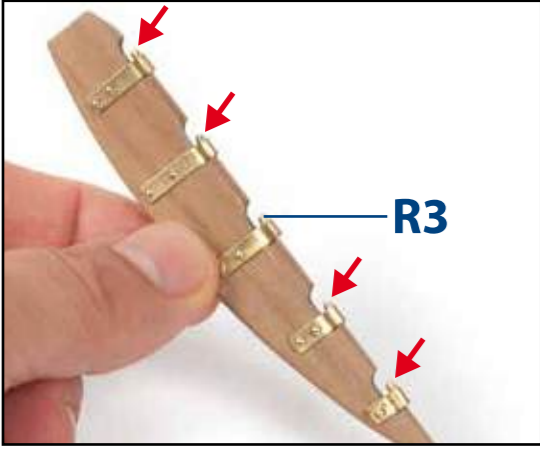
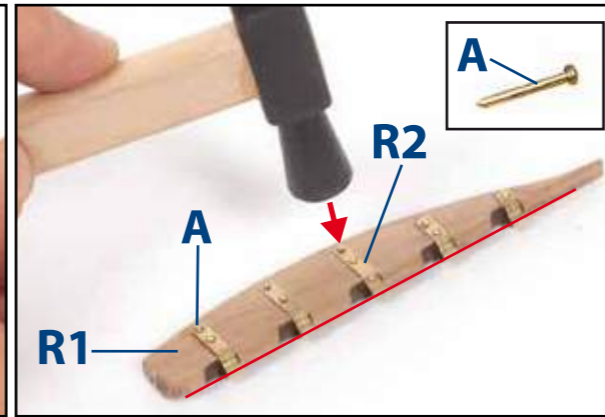
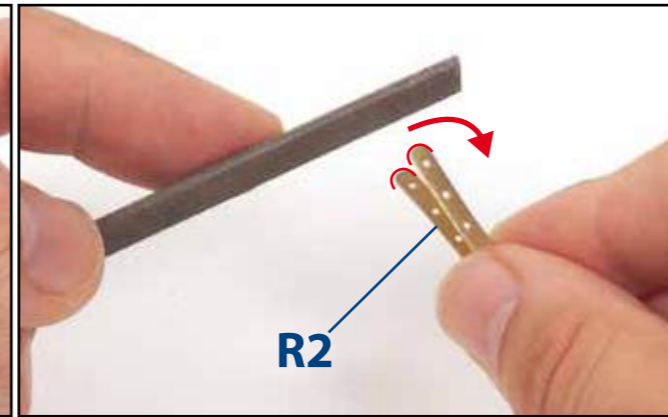
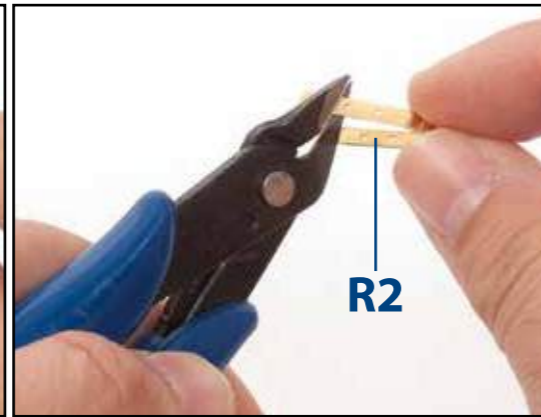
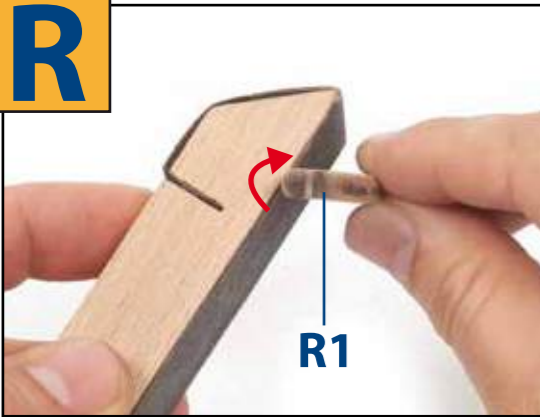

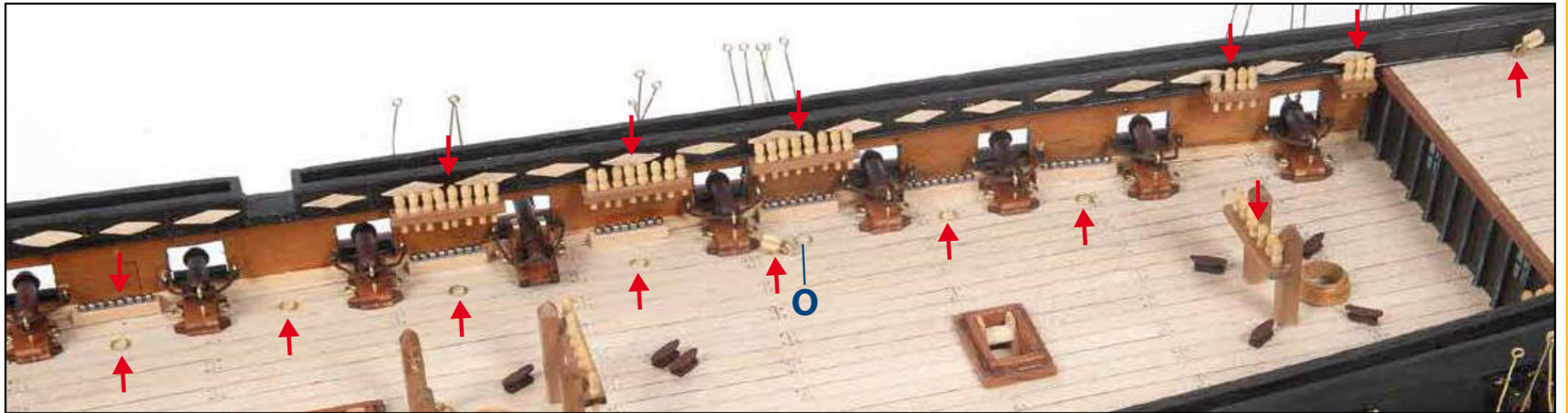
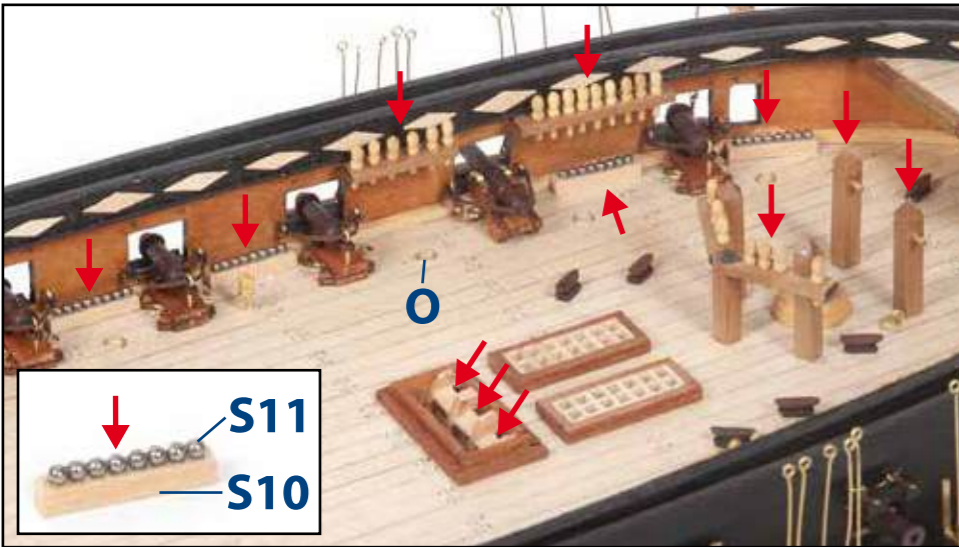
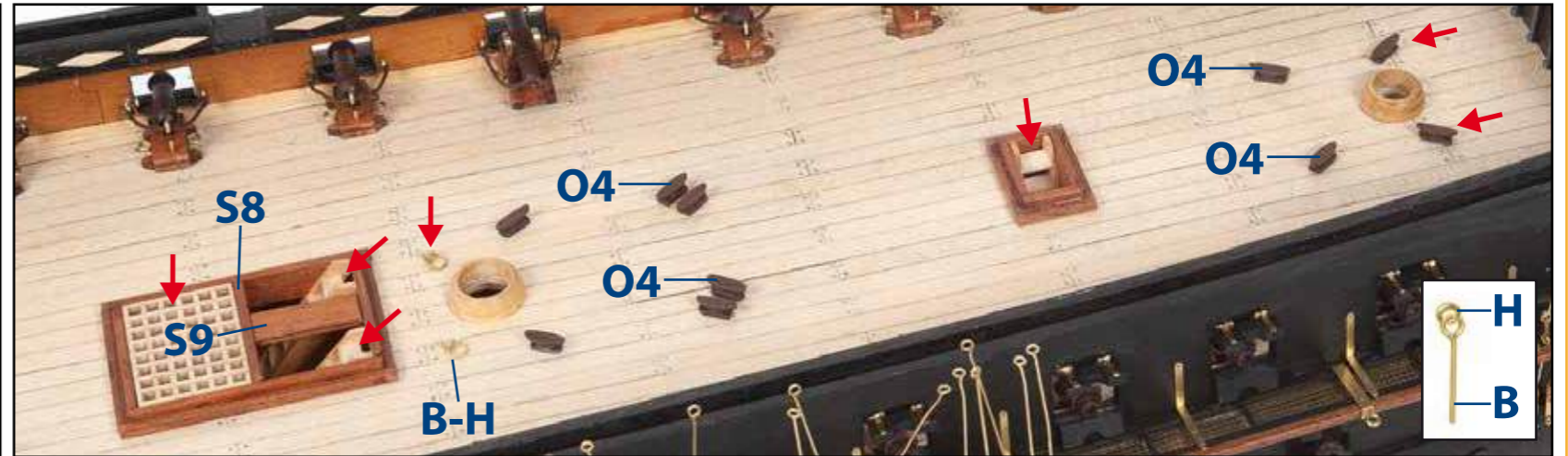
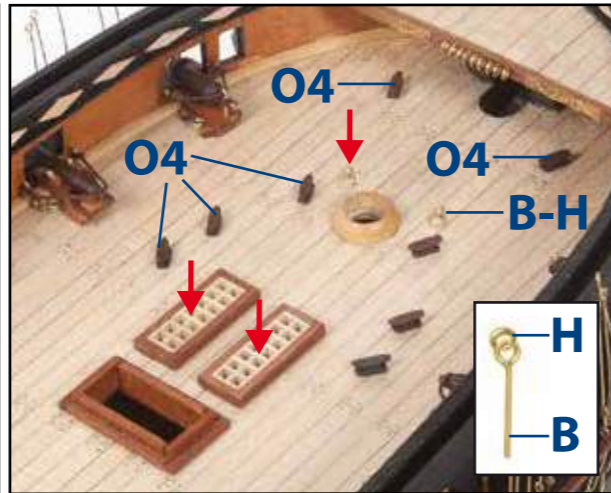
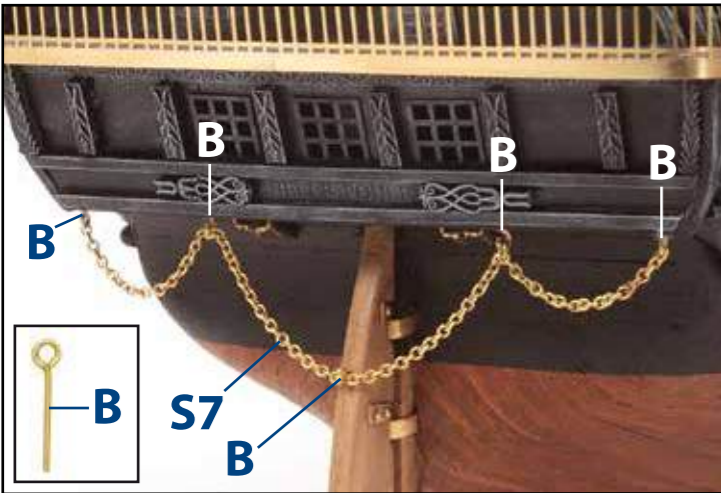
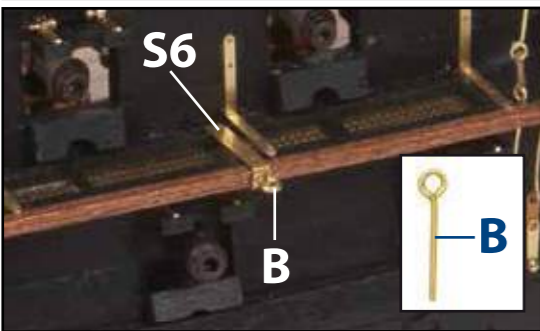
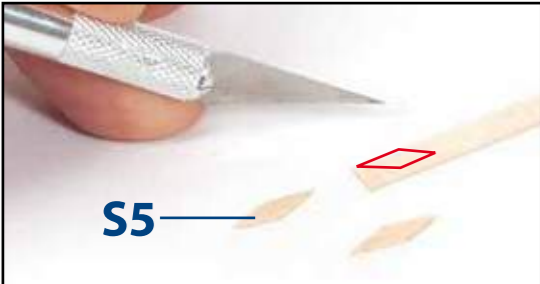
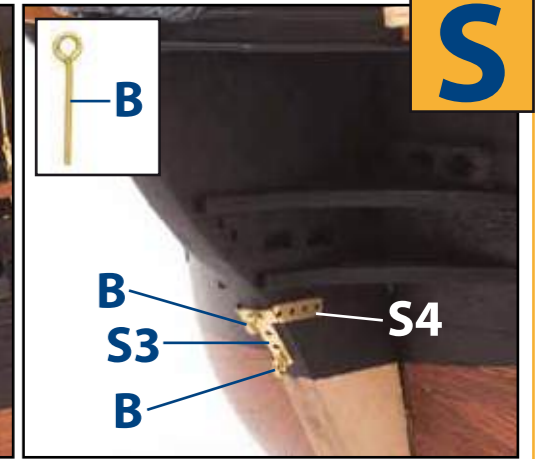
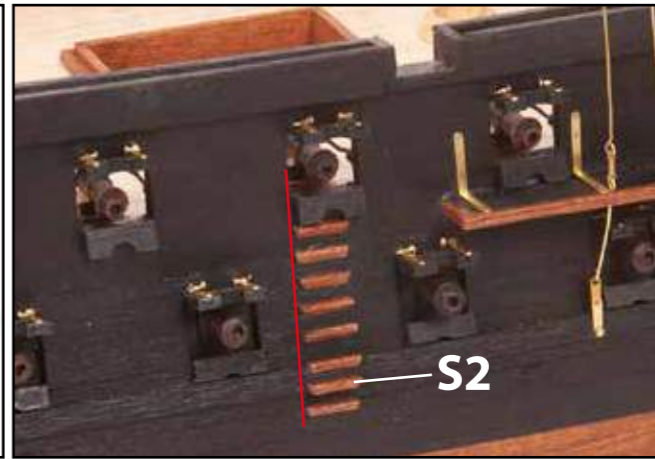
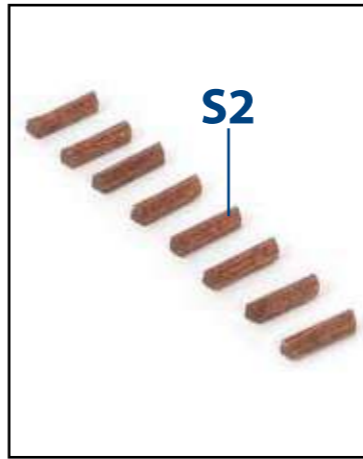
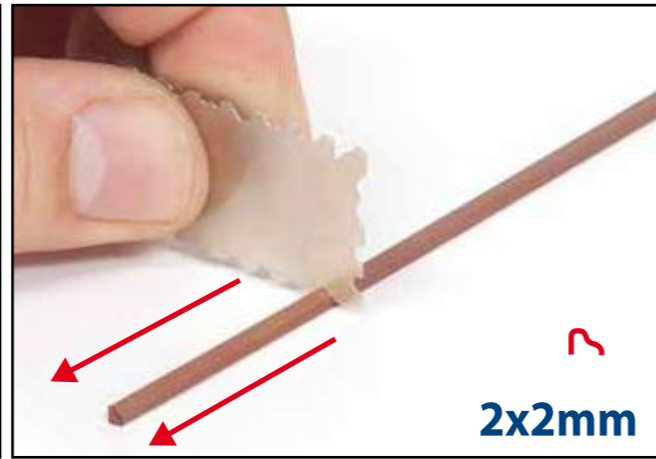
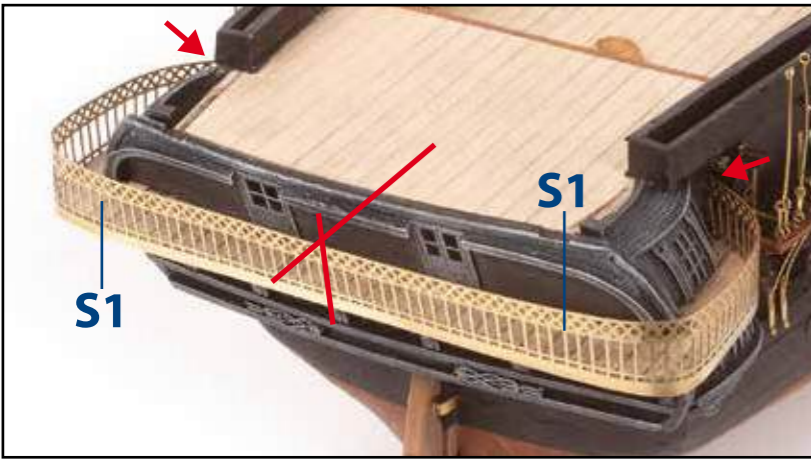

**T**

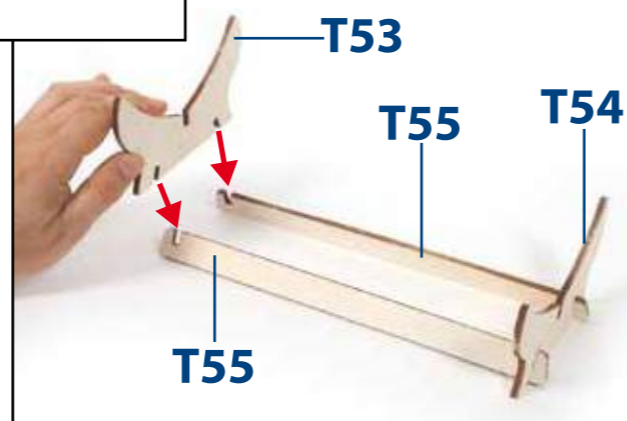
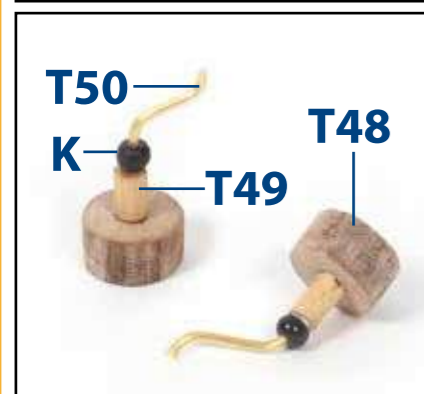
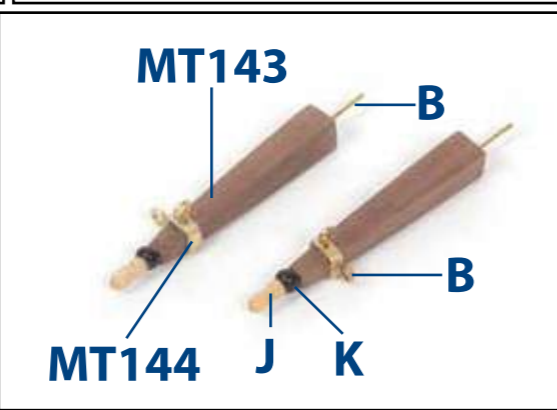
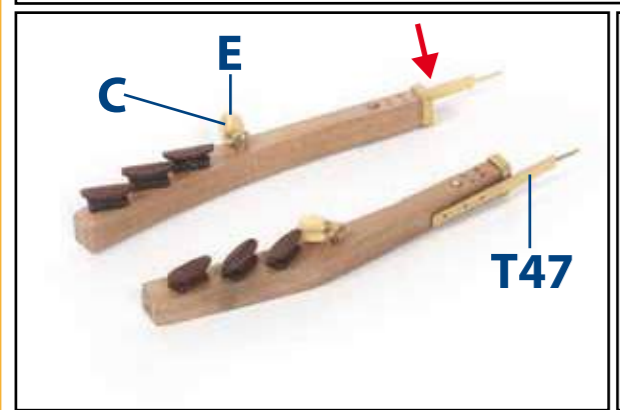
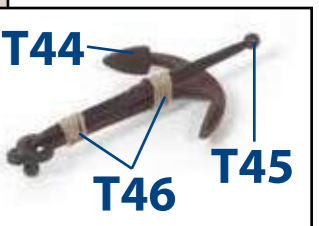
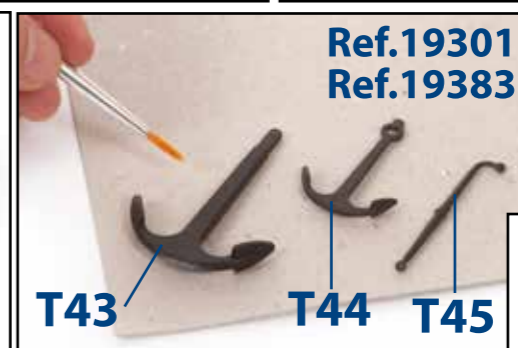
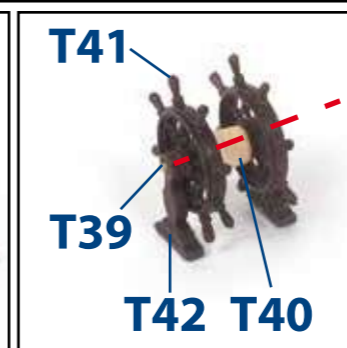
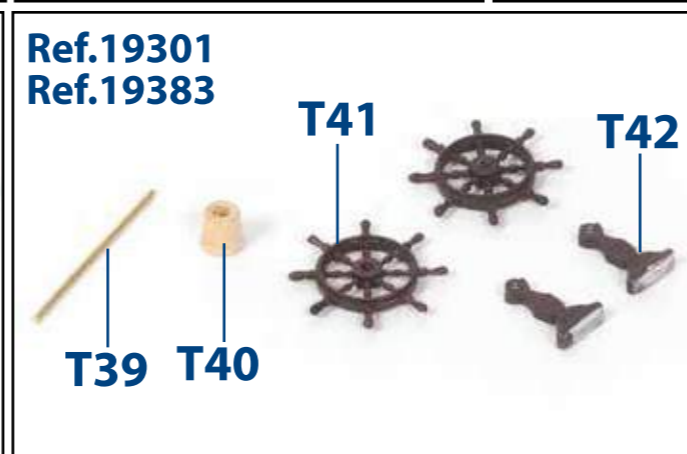
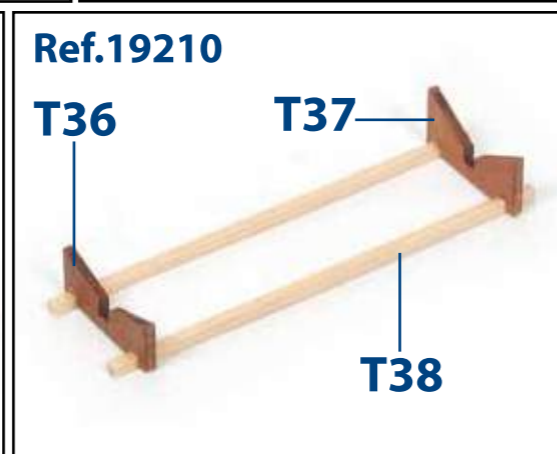
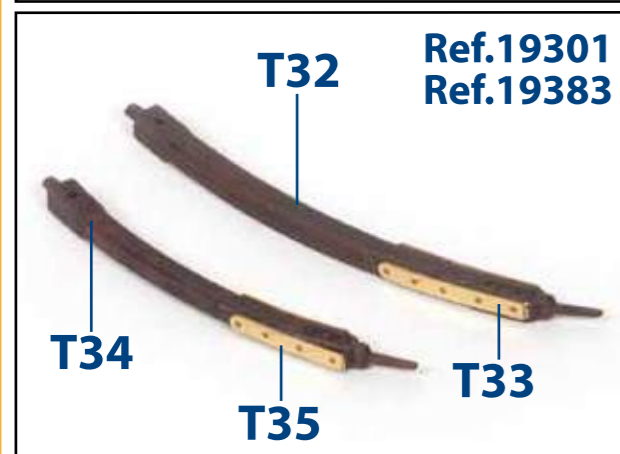
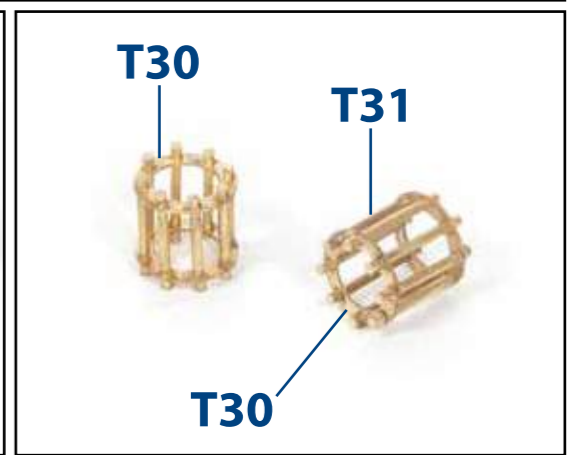
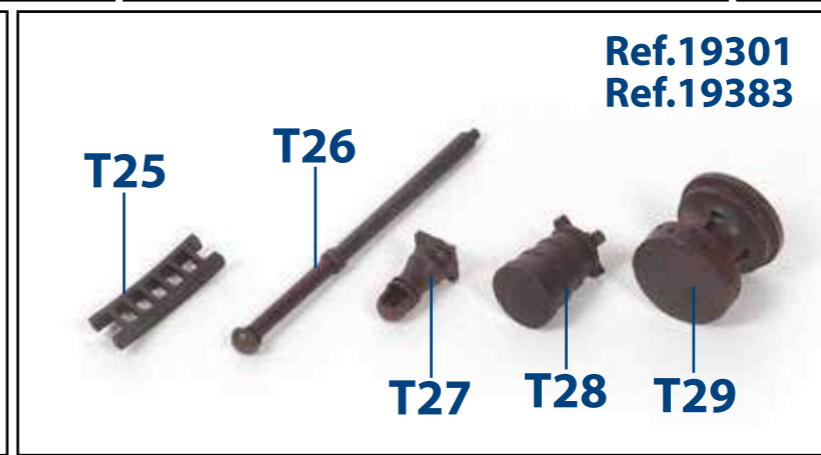
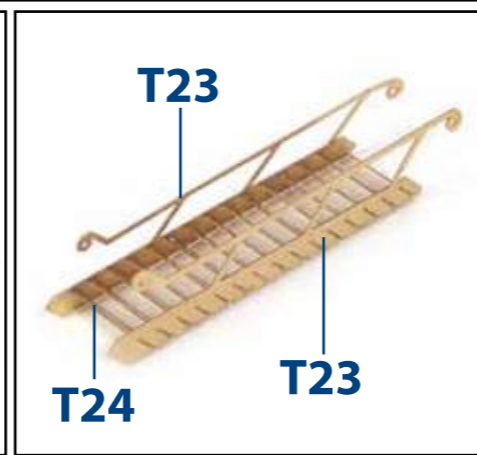
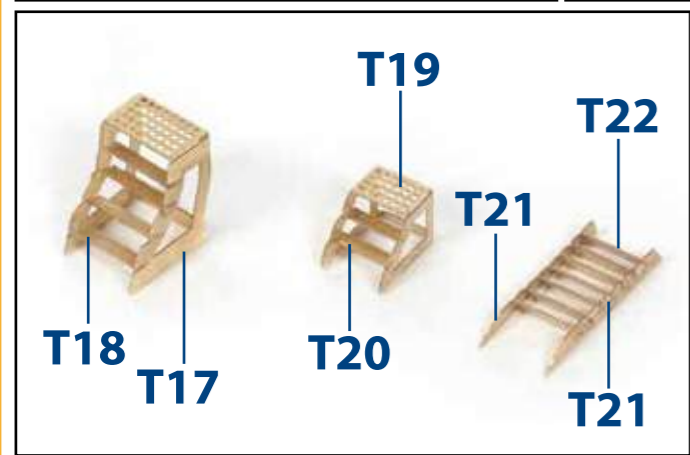
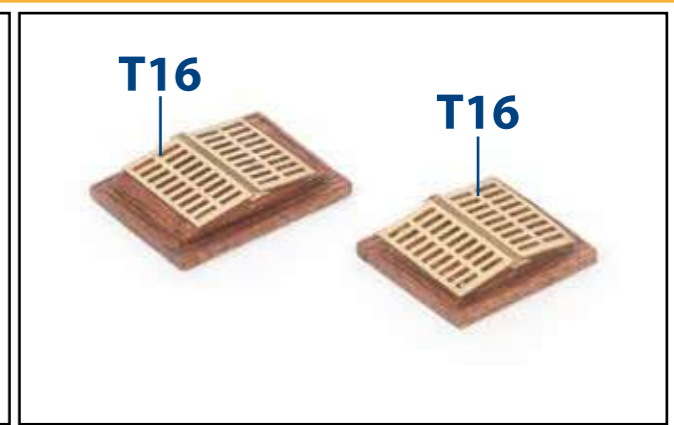
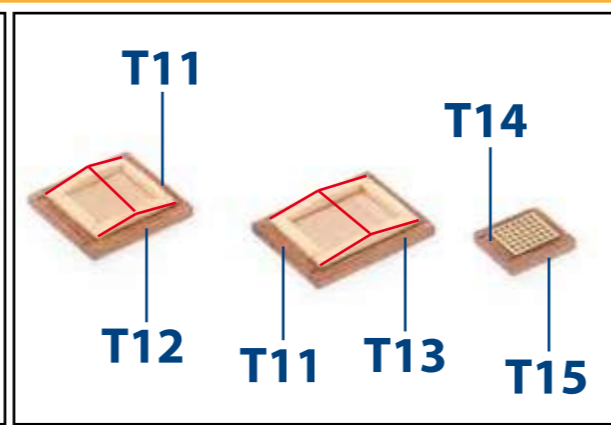
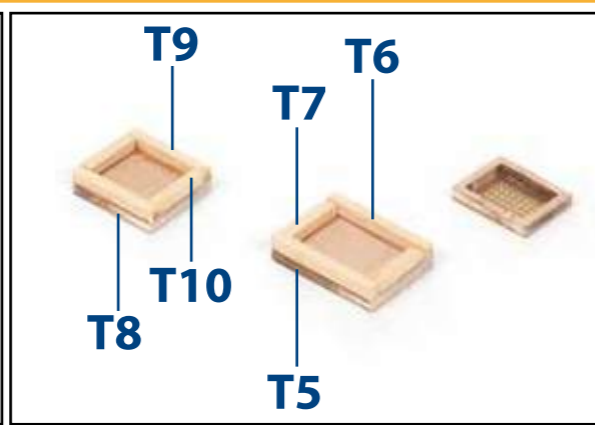
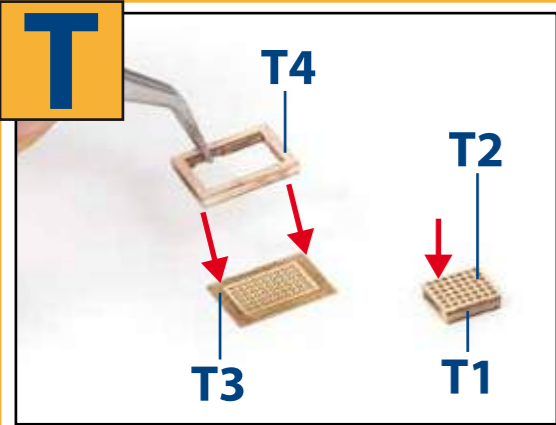

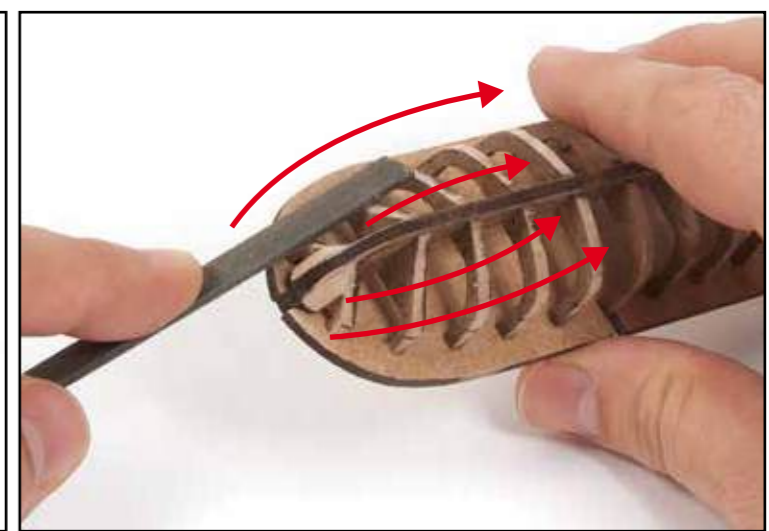
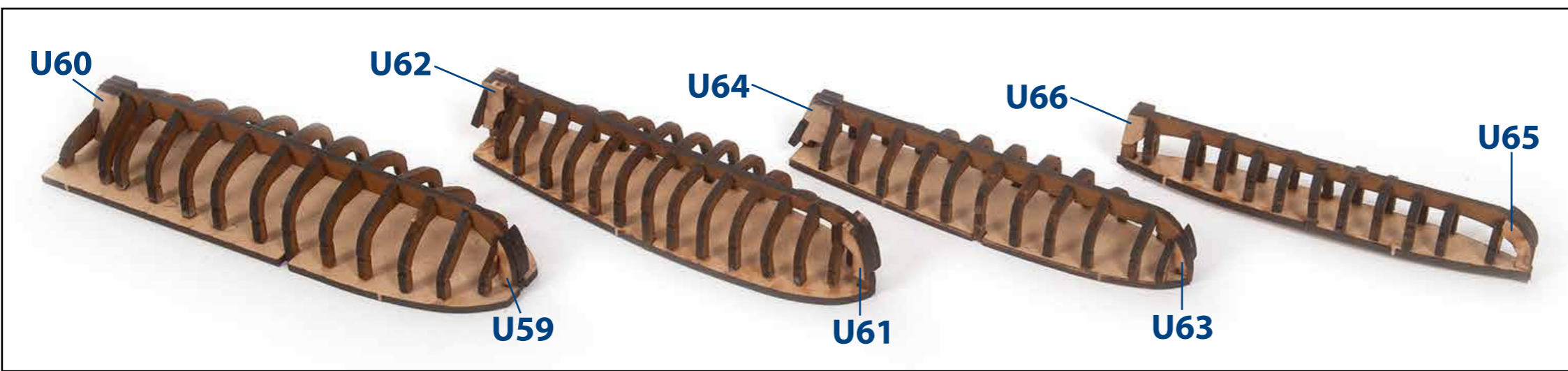
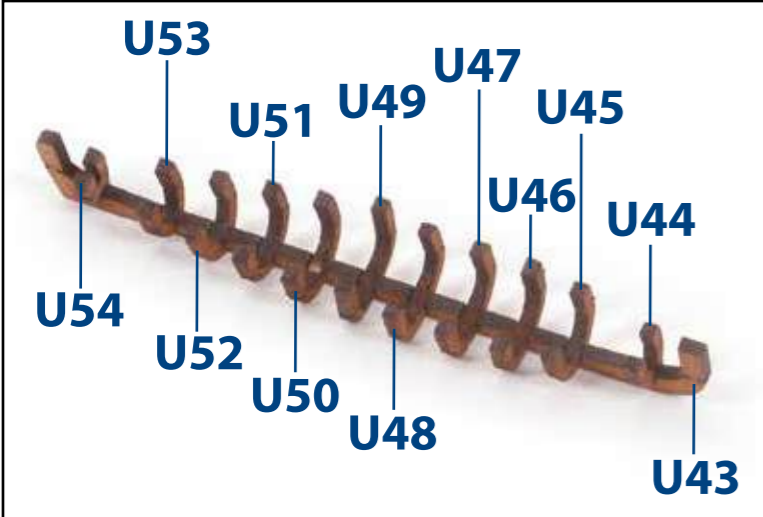
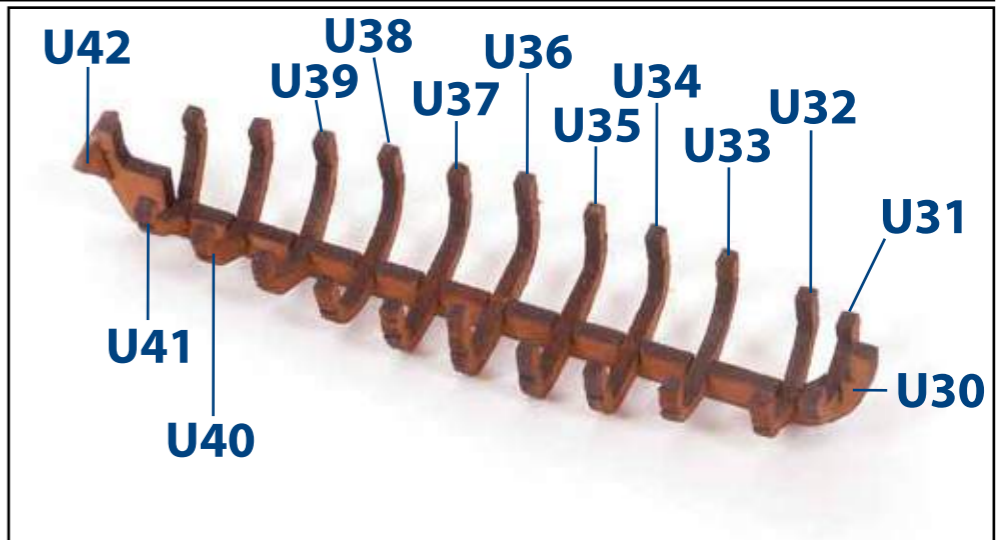
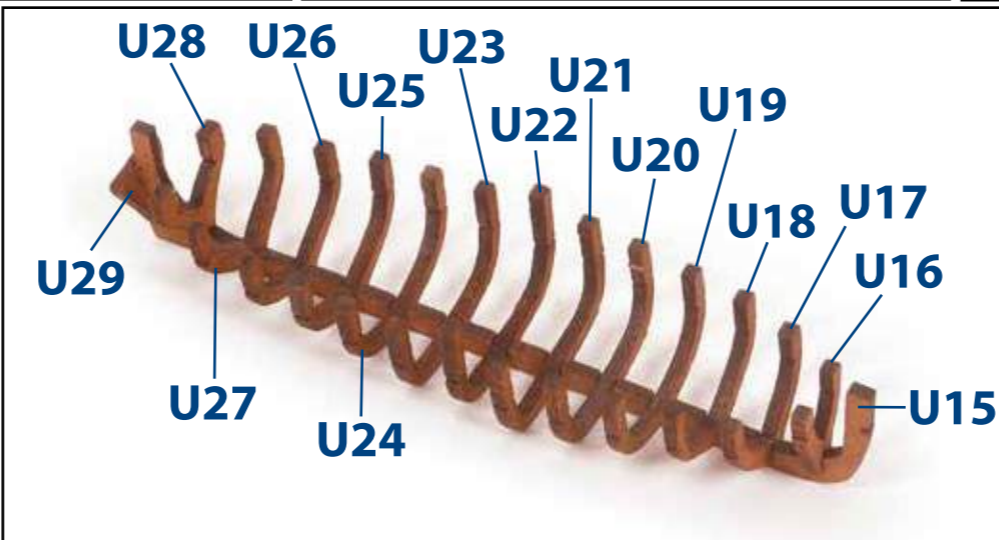
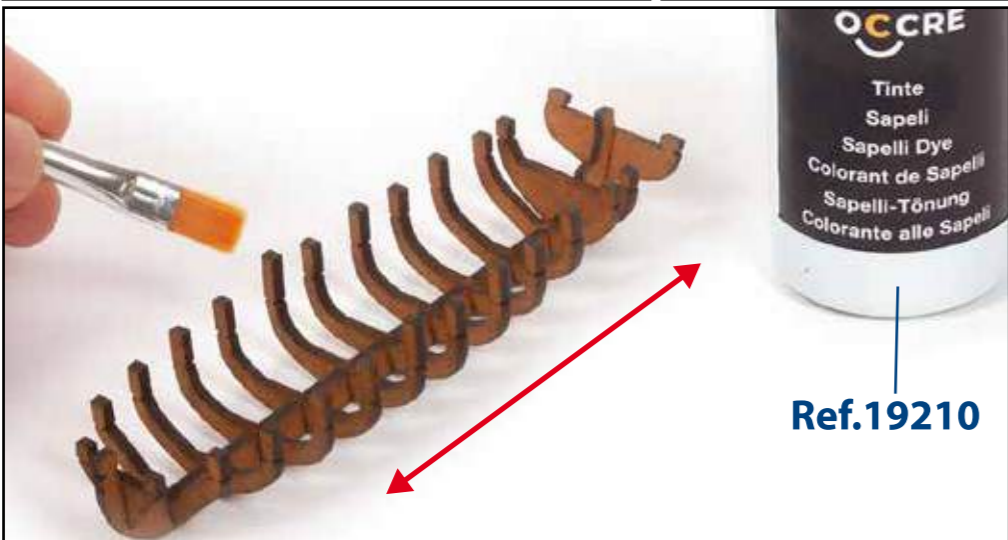
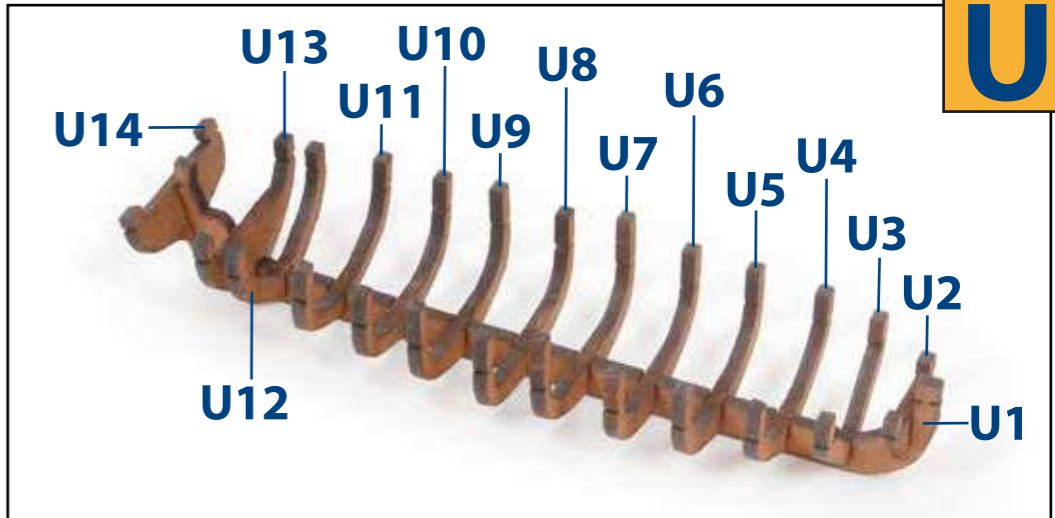
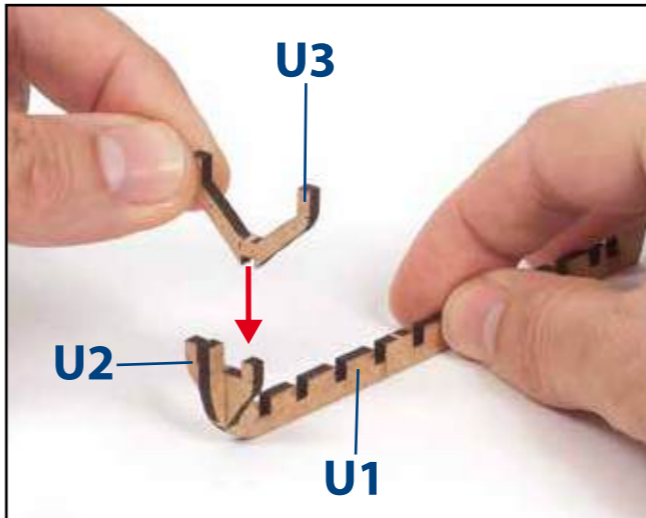
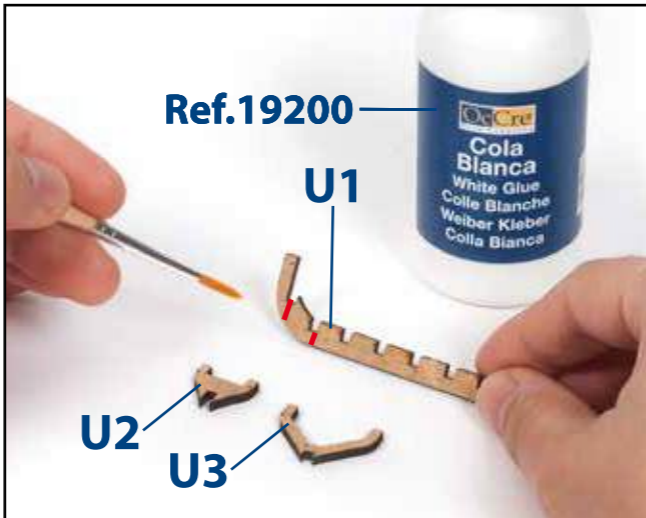
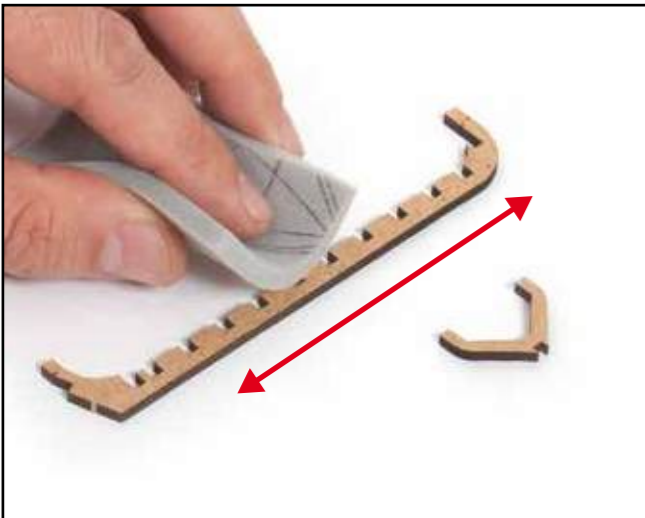

**V**

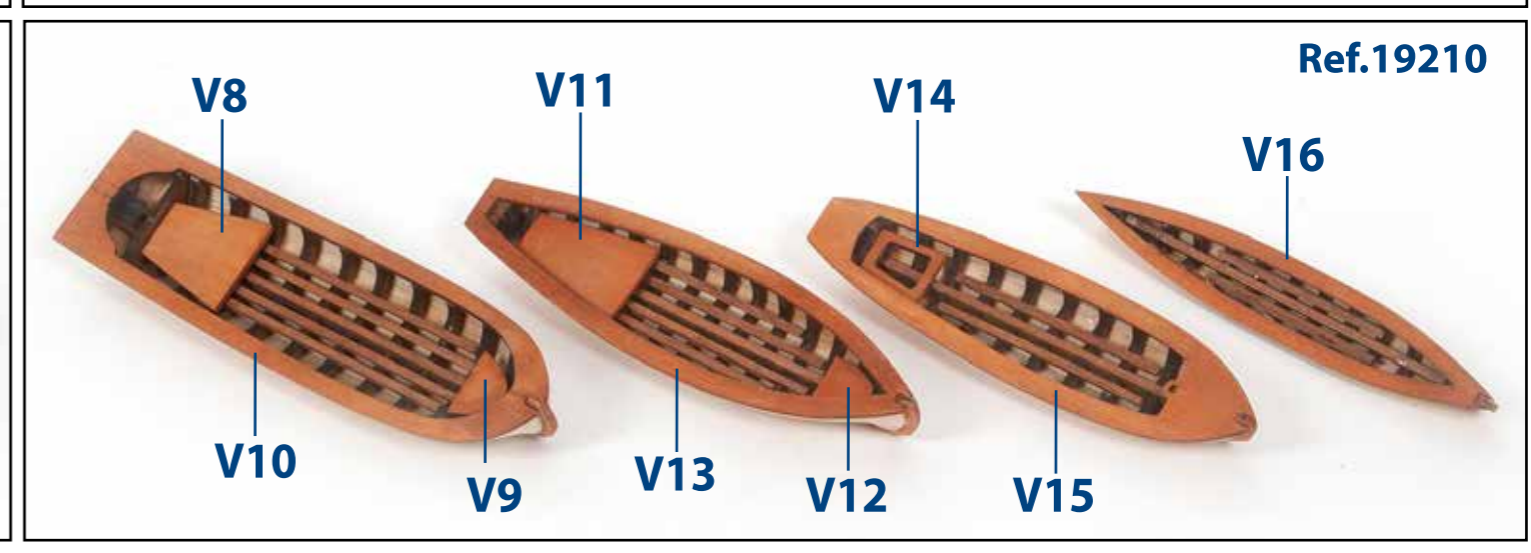
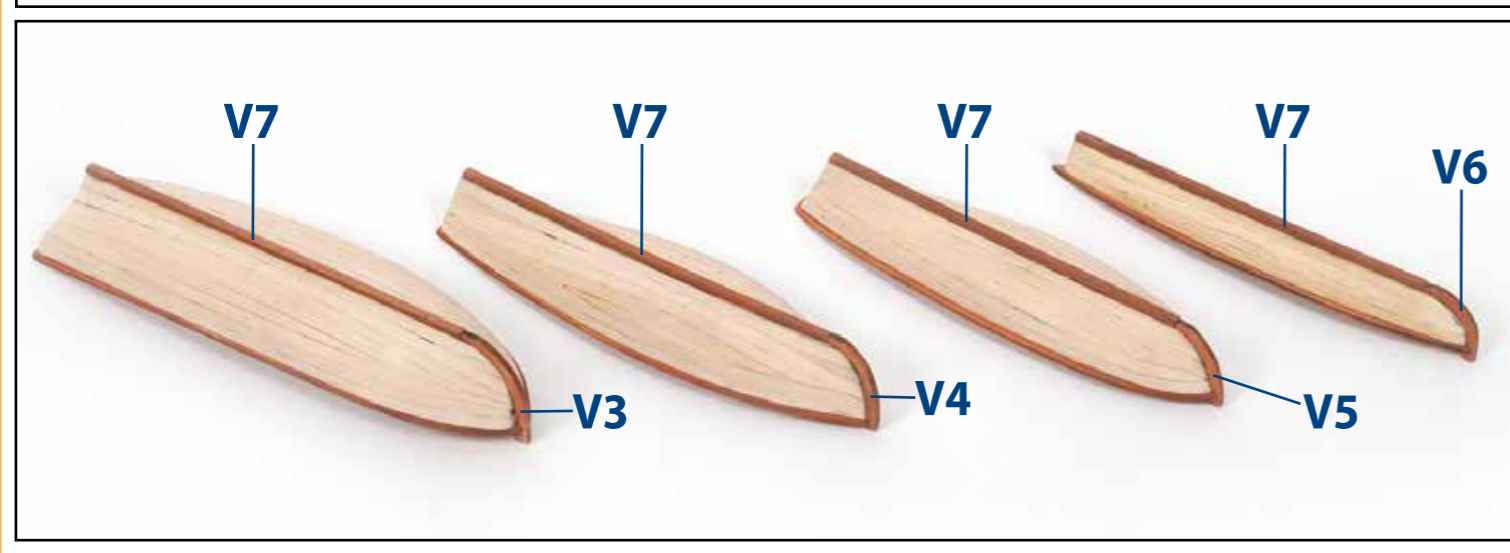
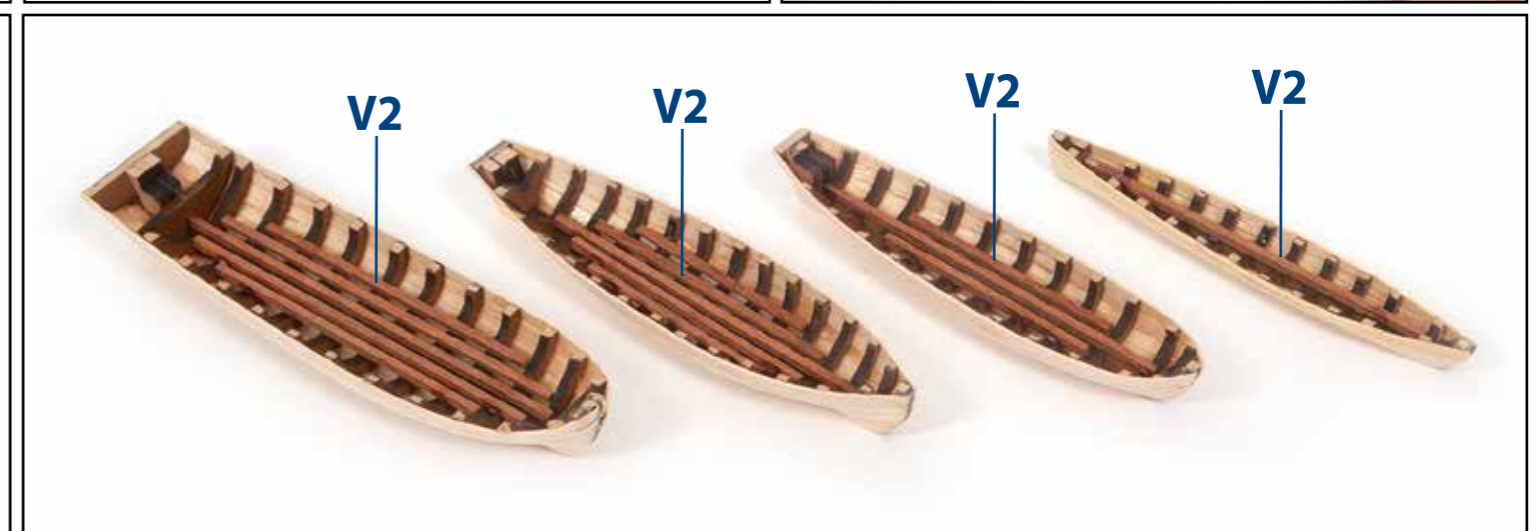
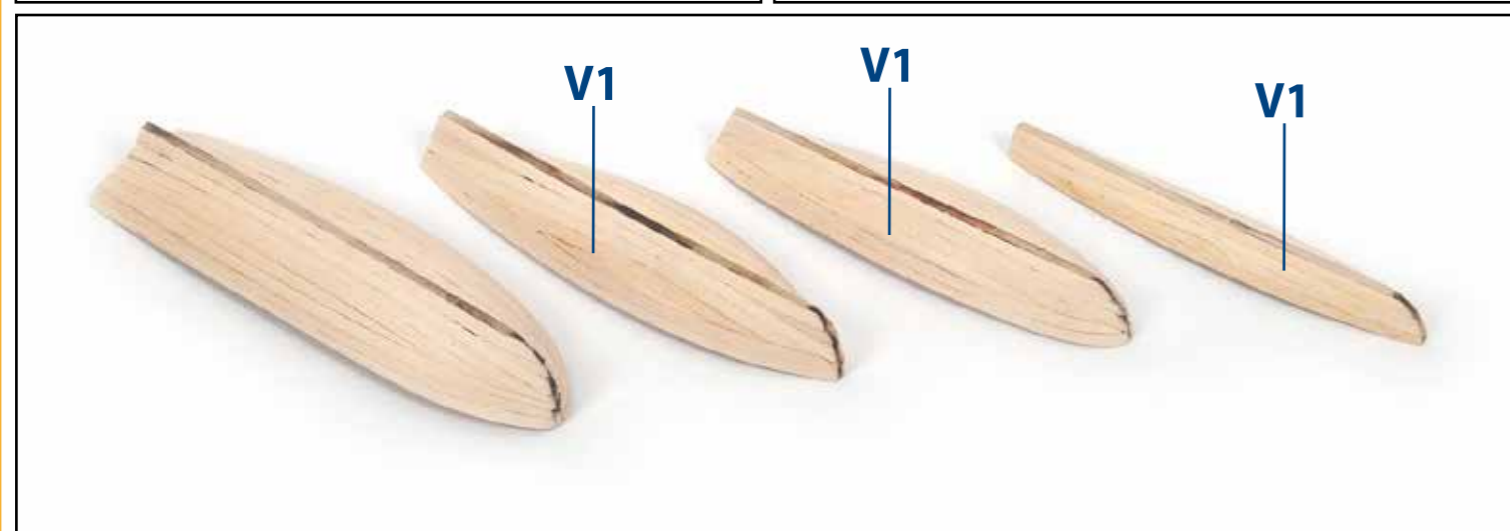
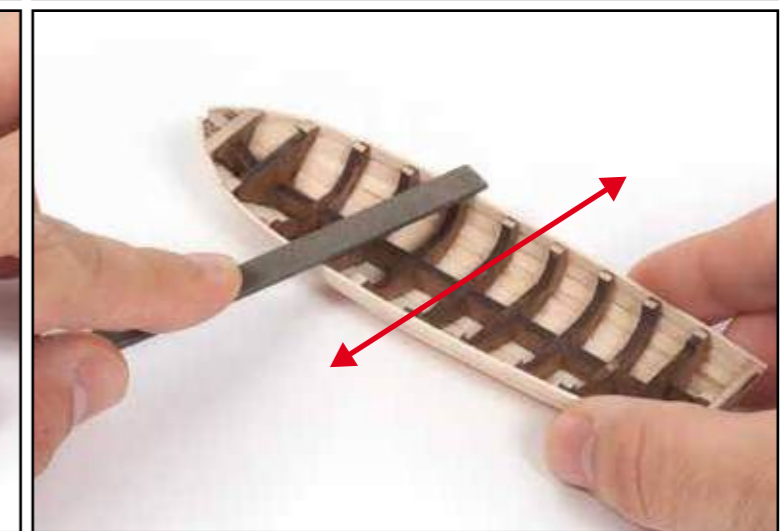
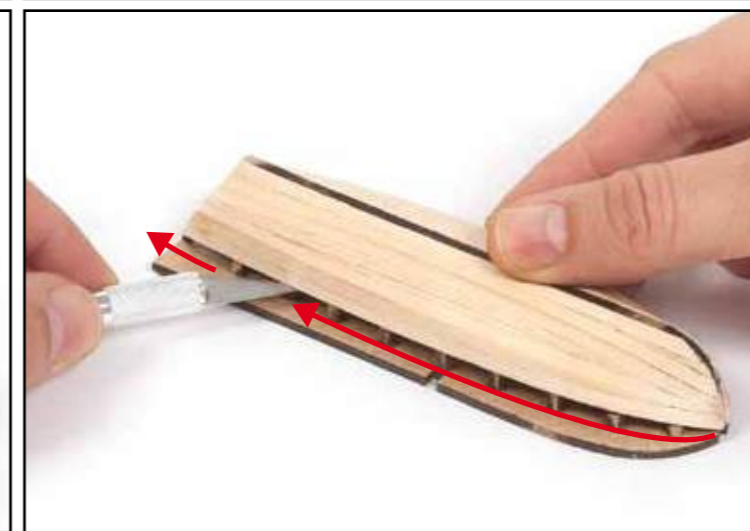
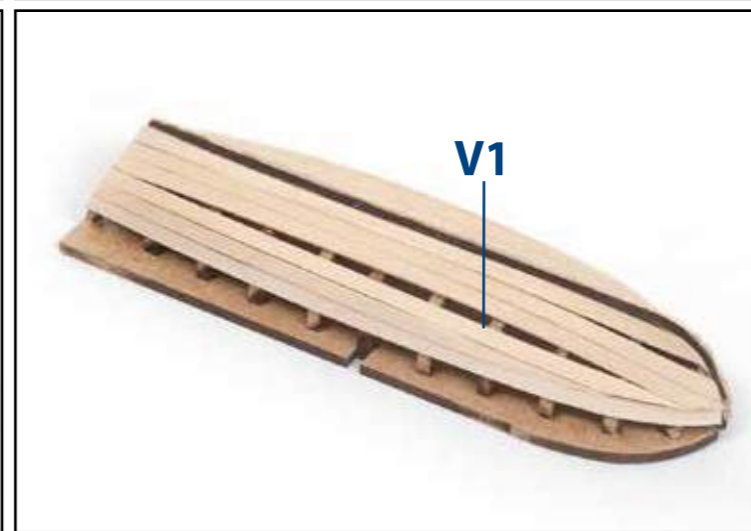
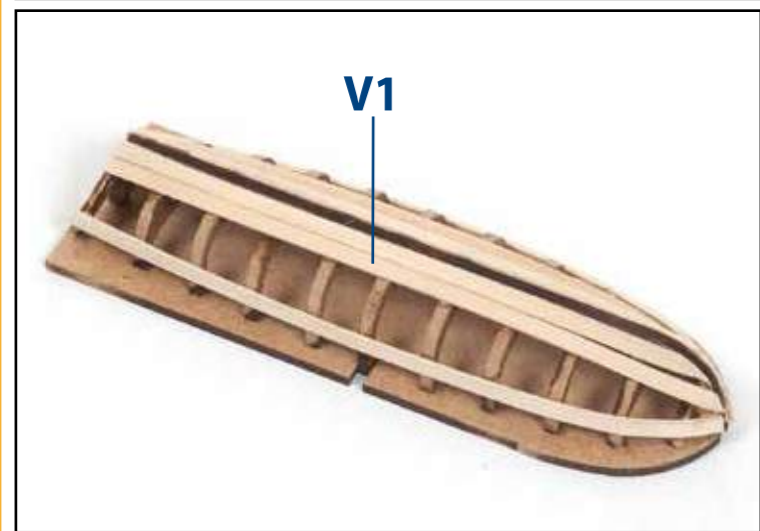
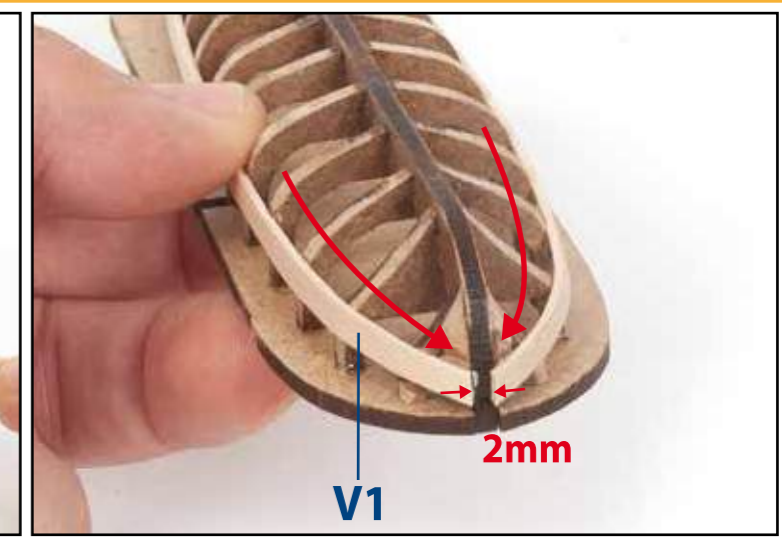
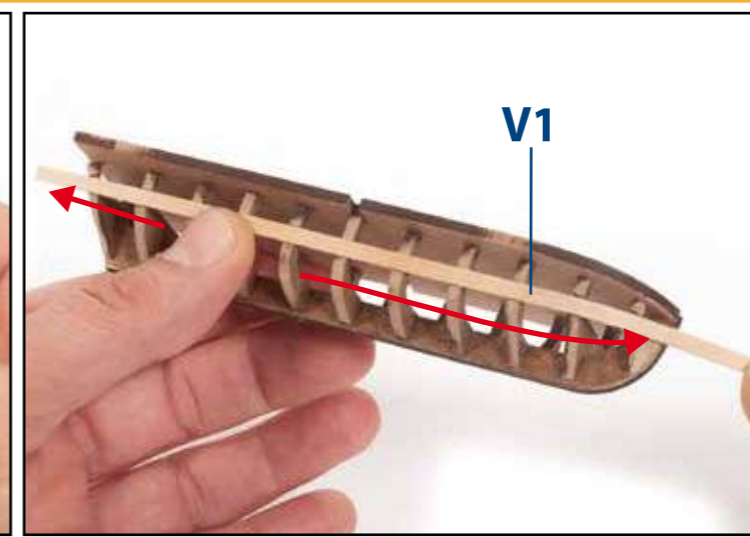
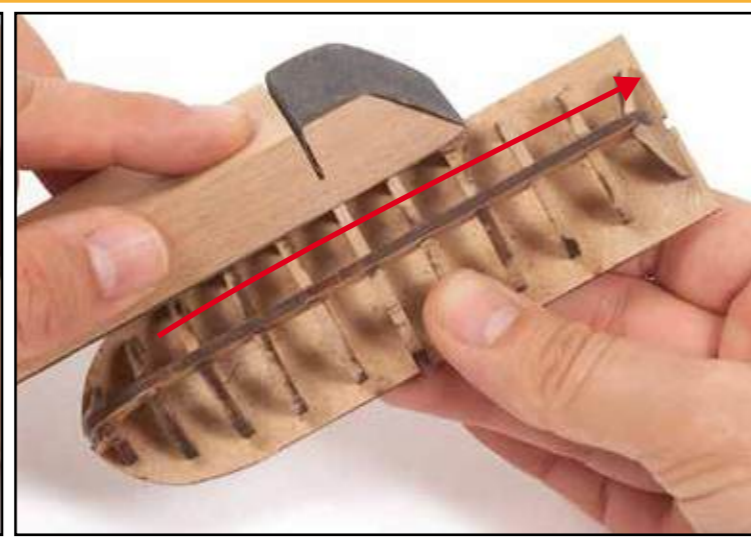
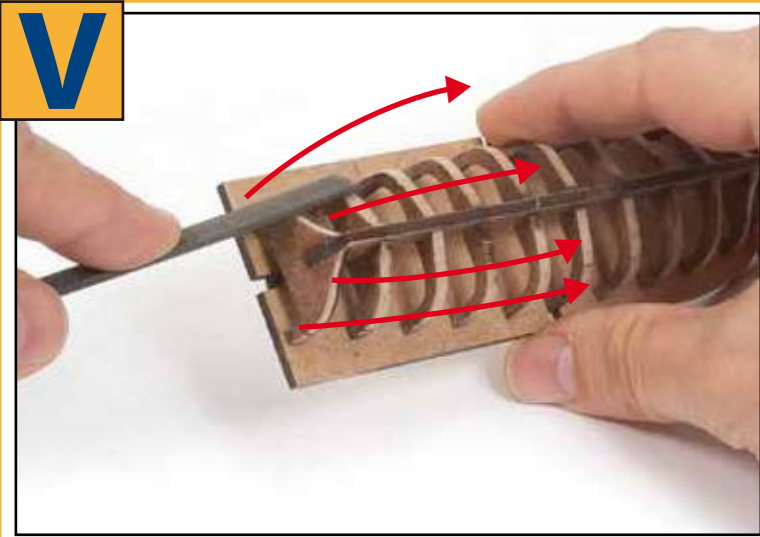

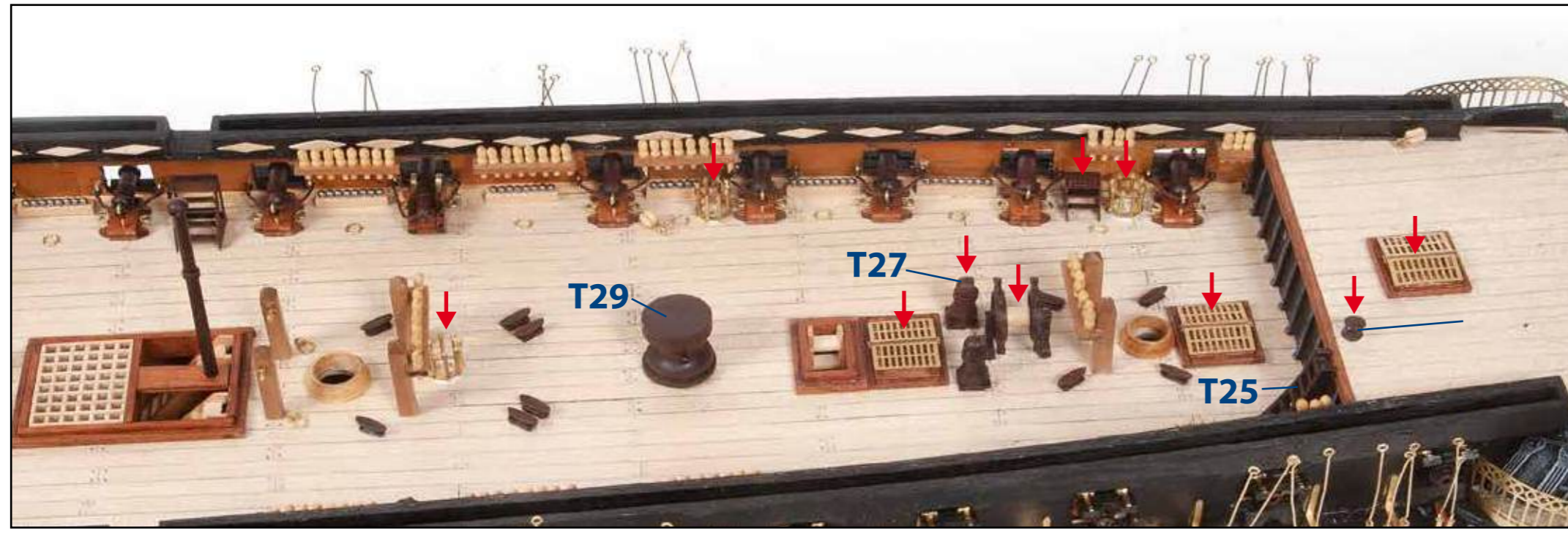
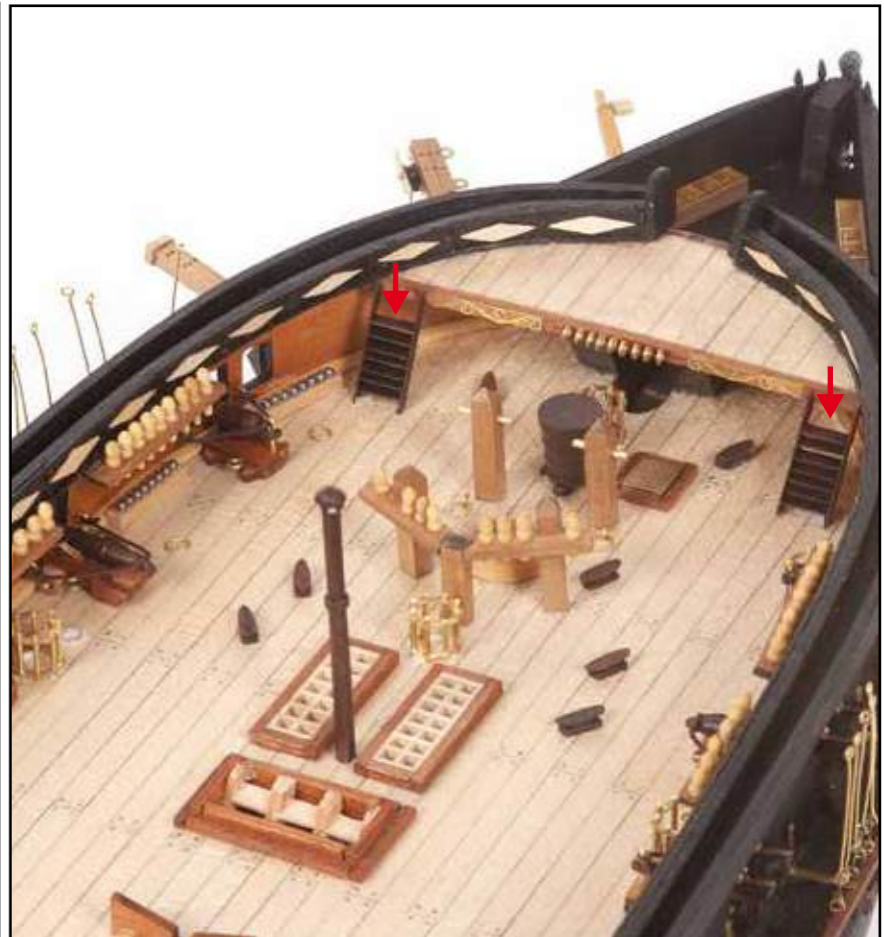
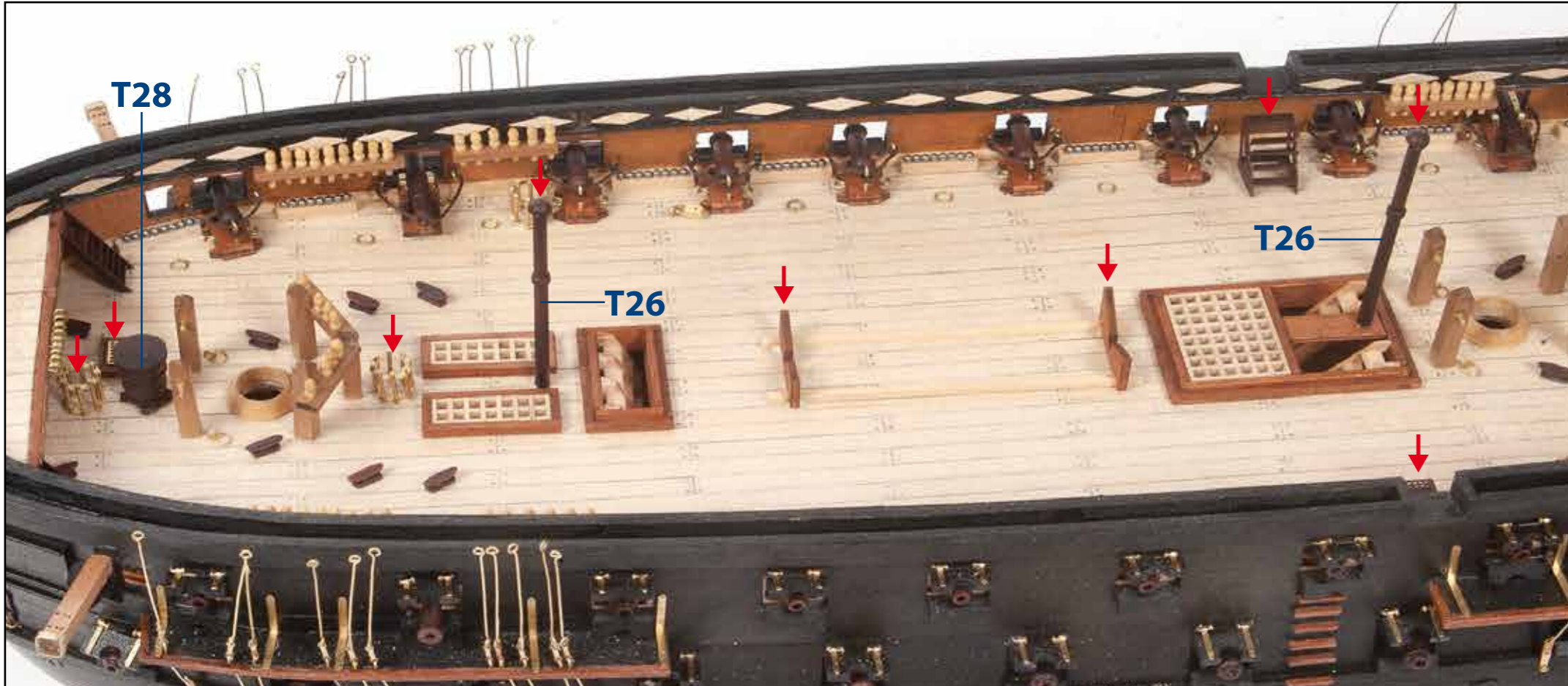
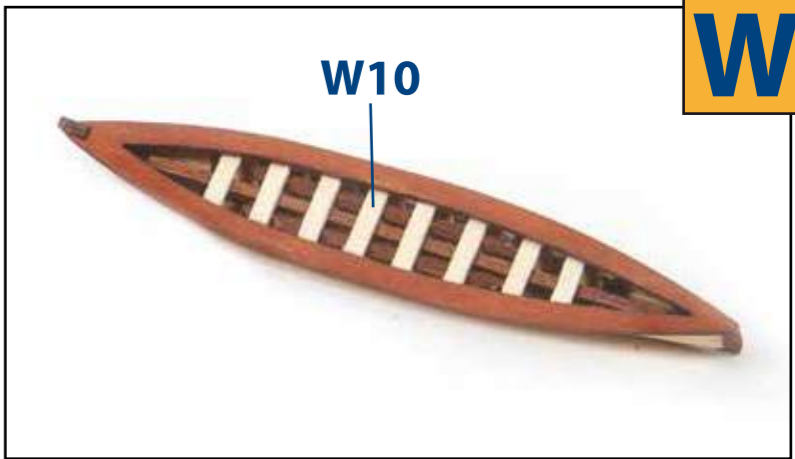
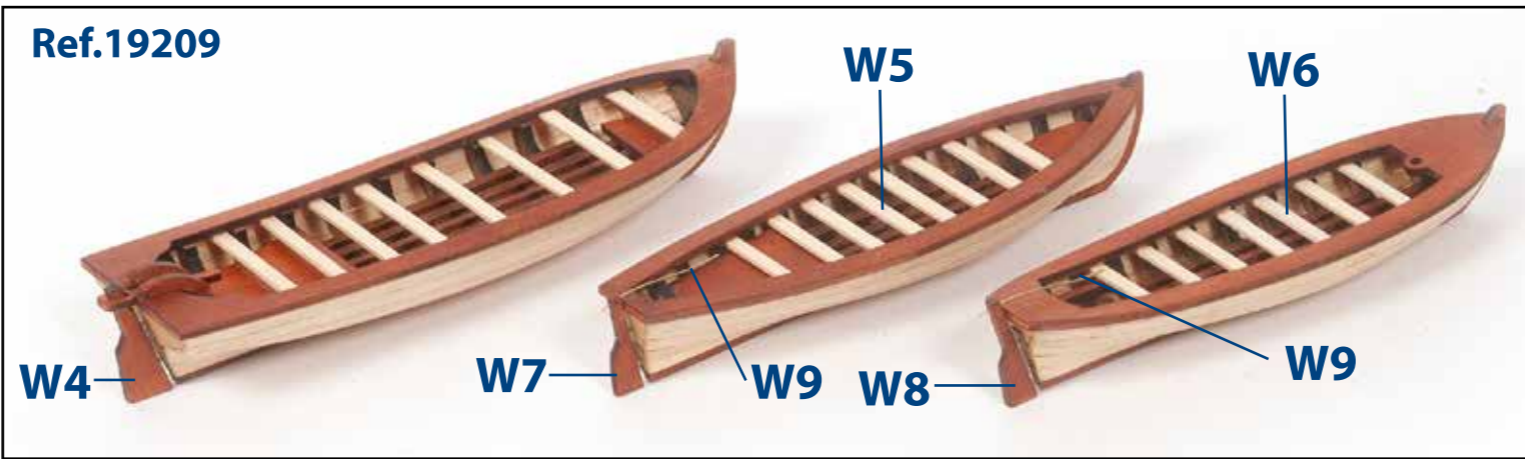
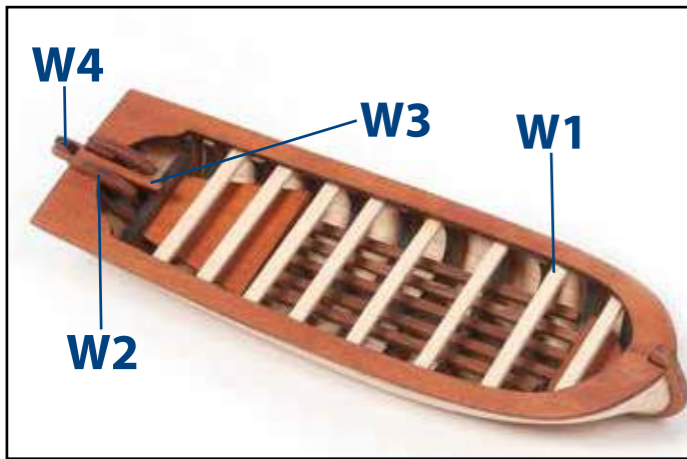

**X**

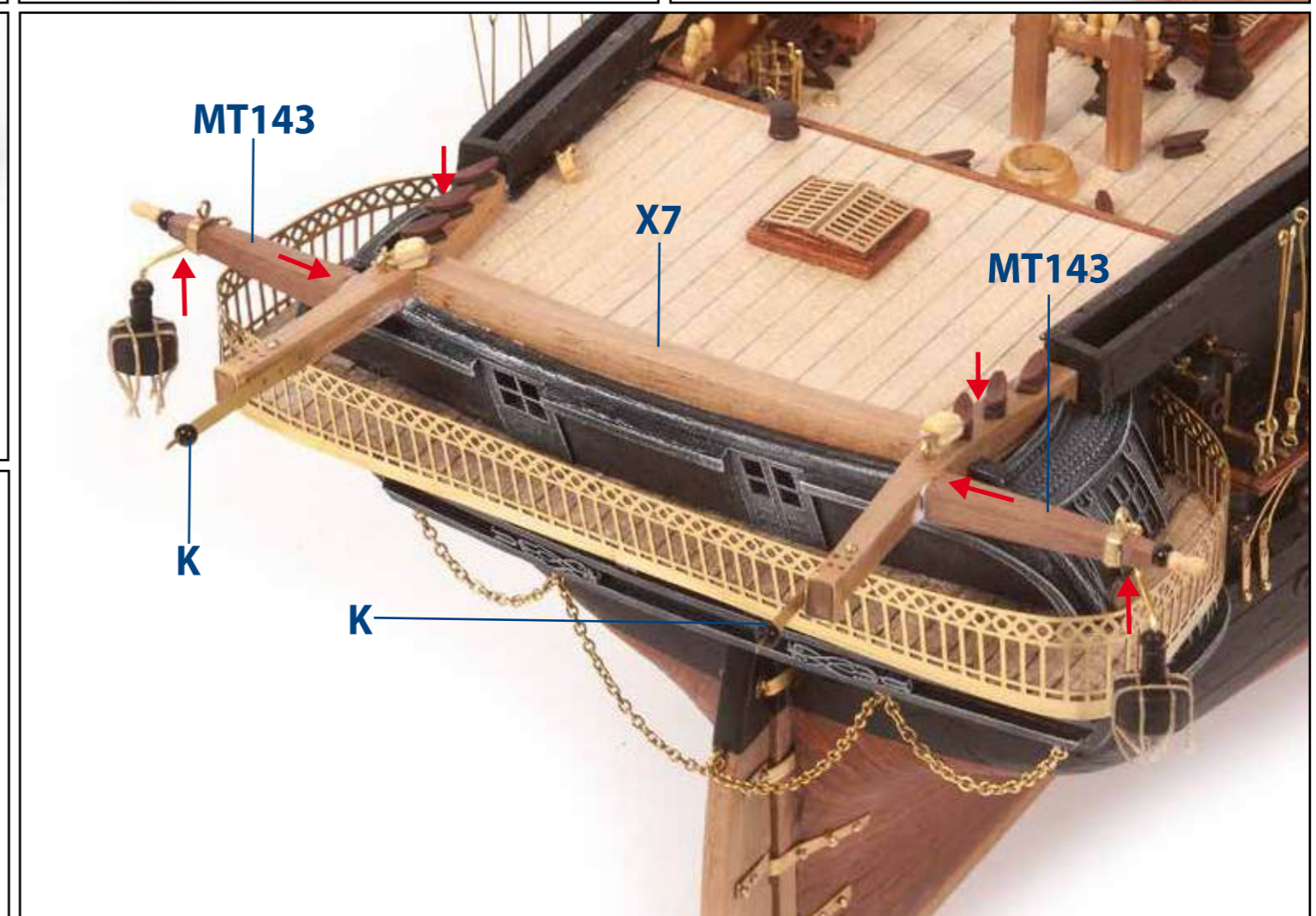
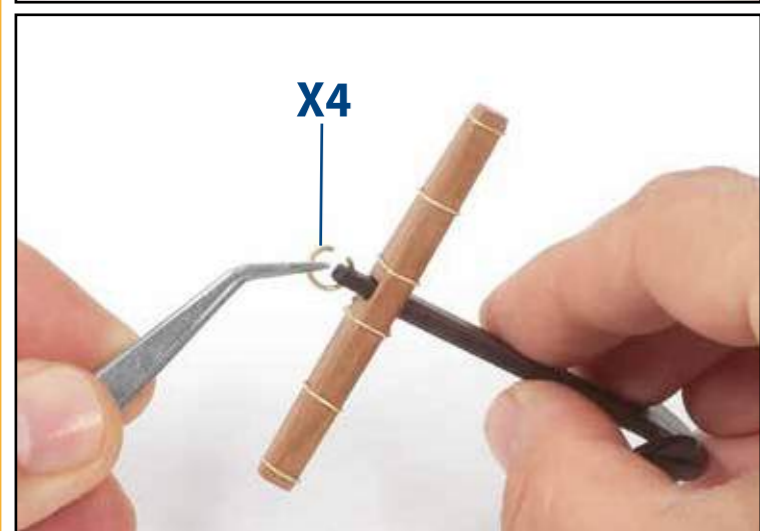
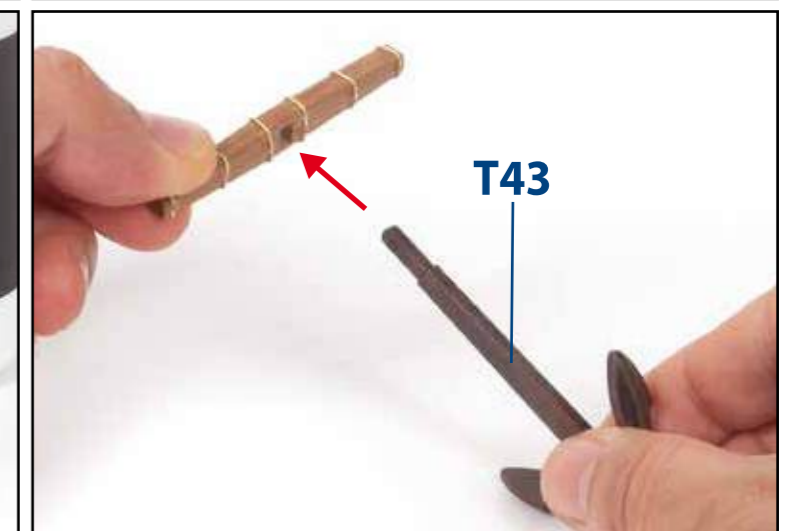
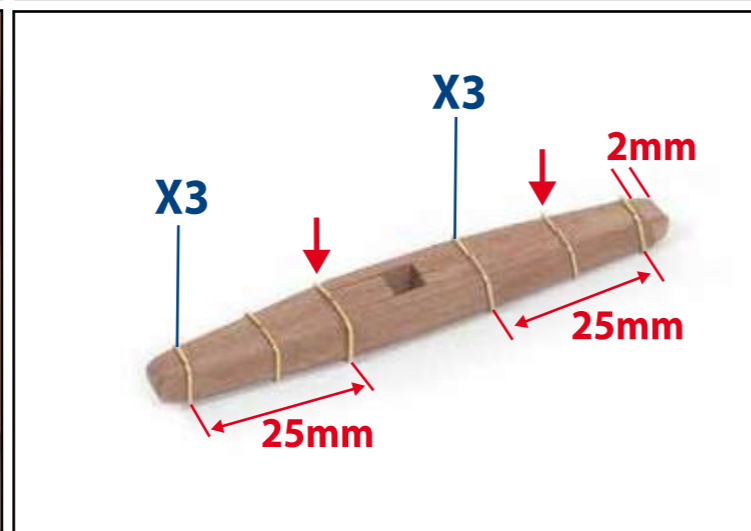
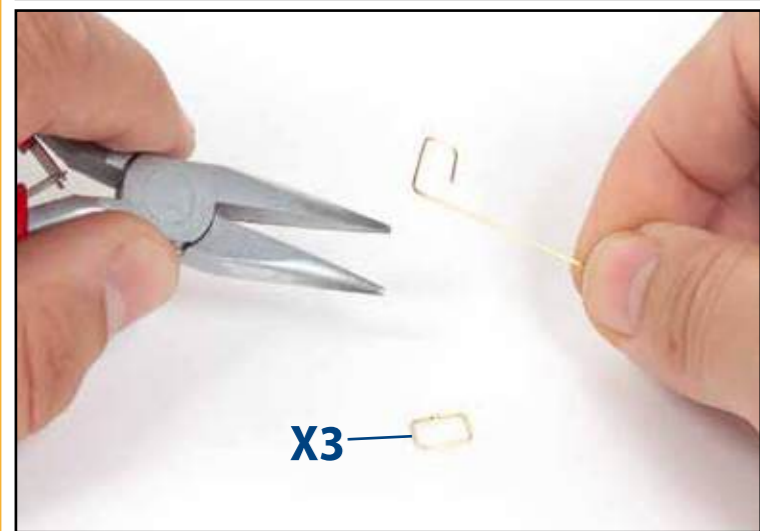
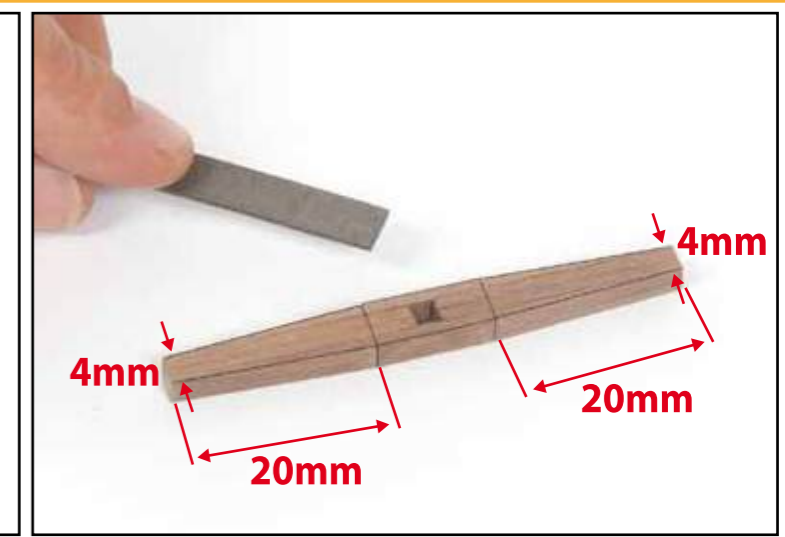
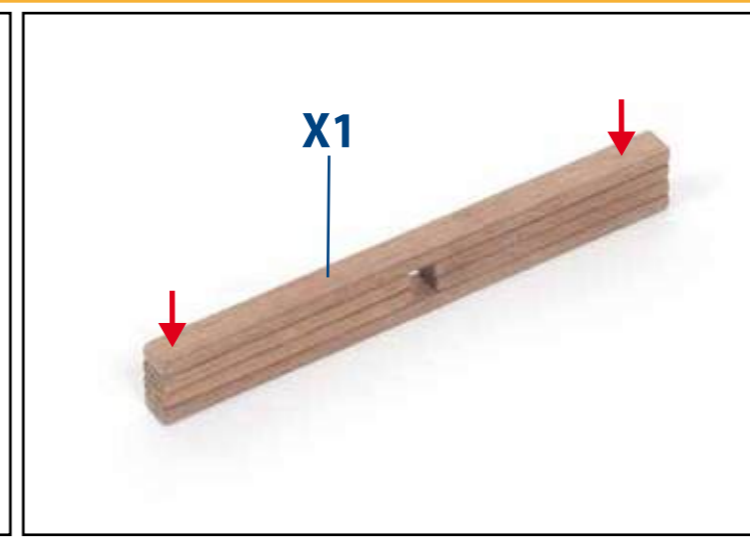
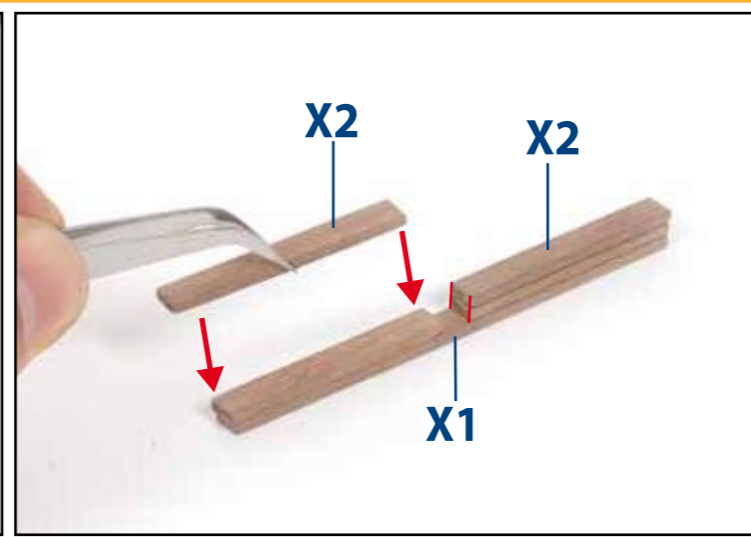
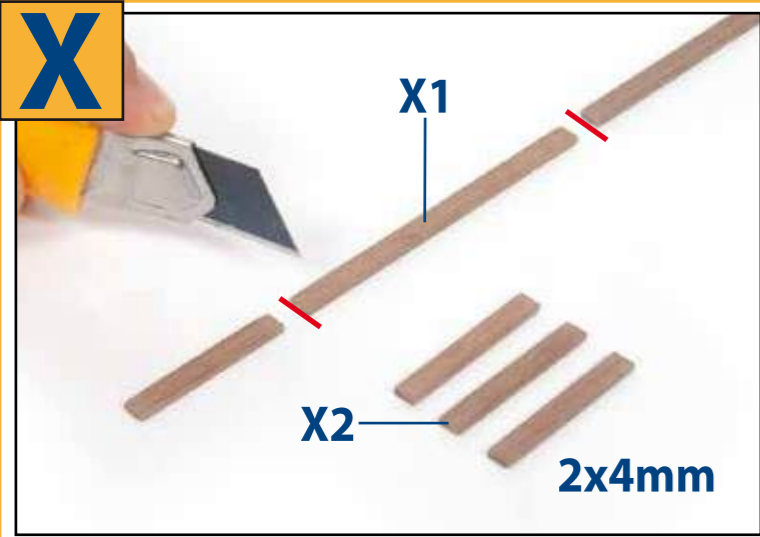

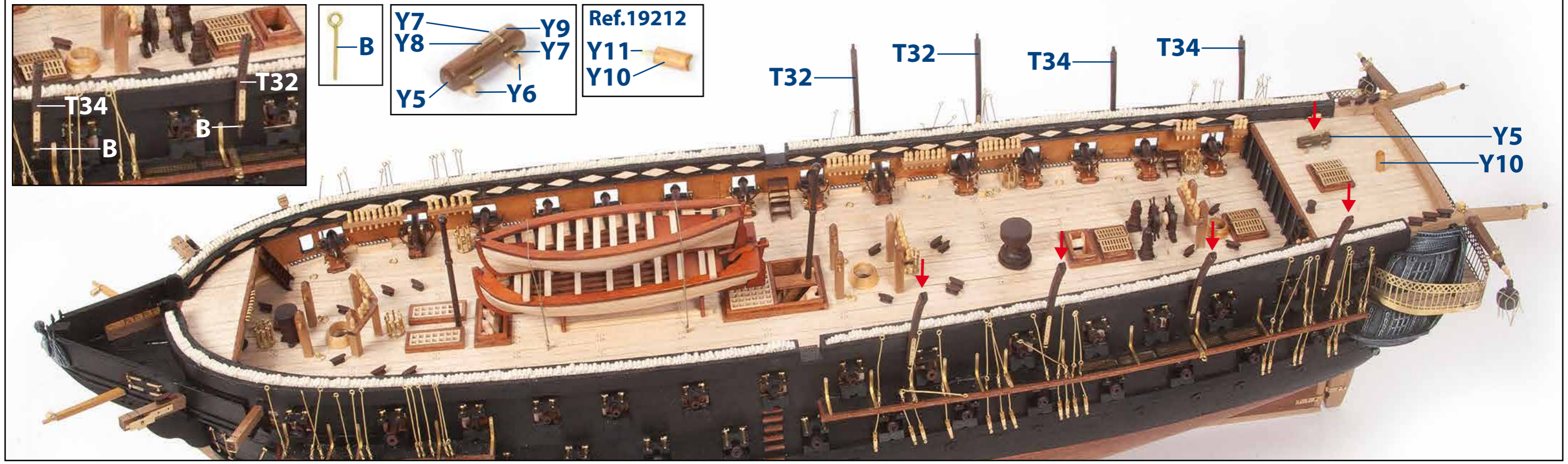
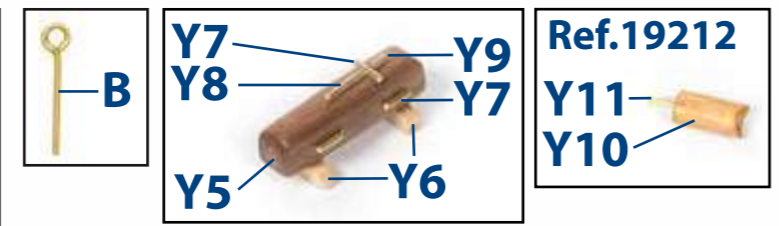
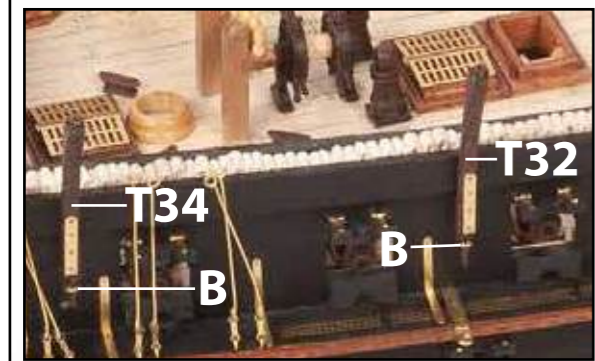
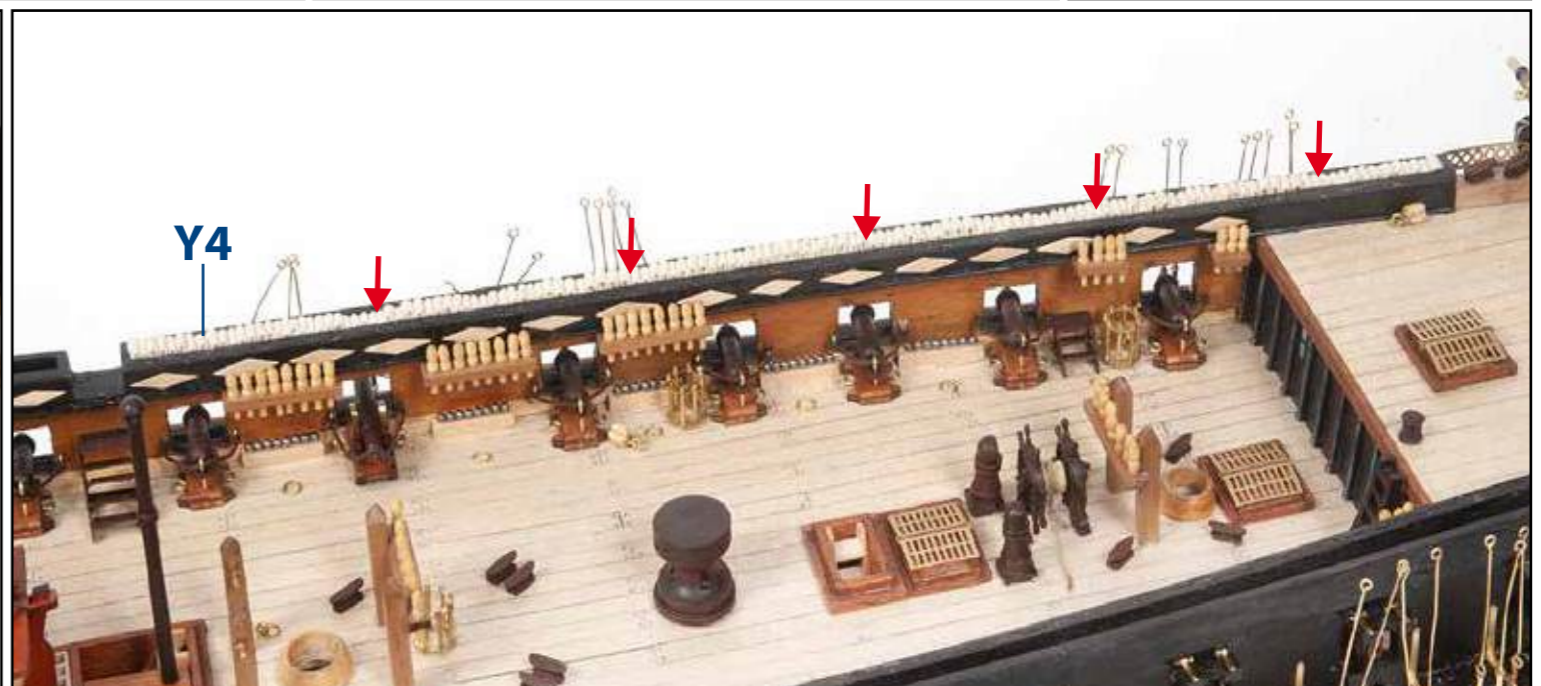
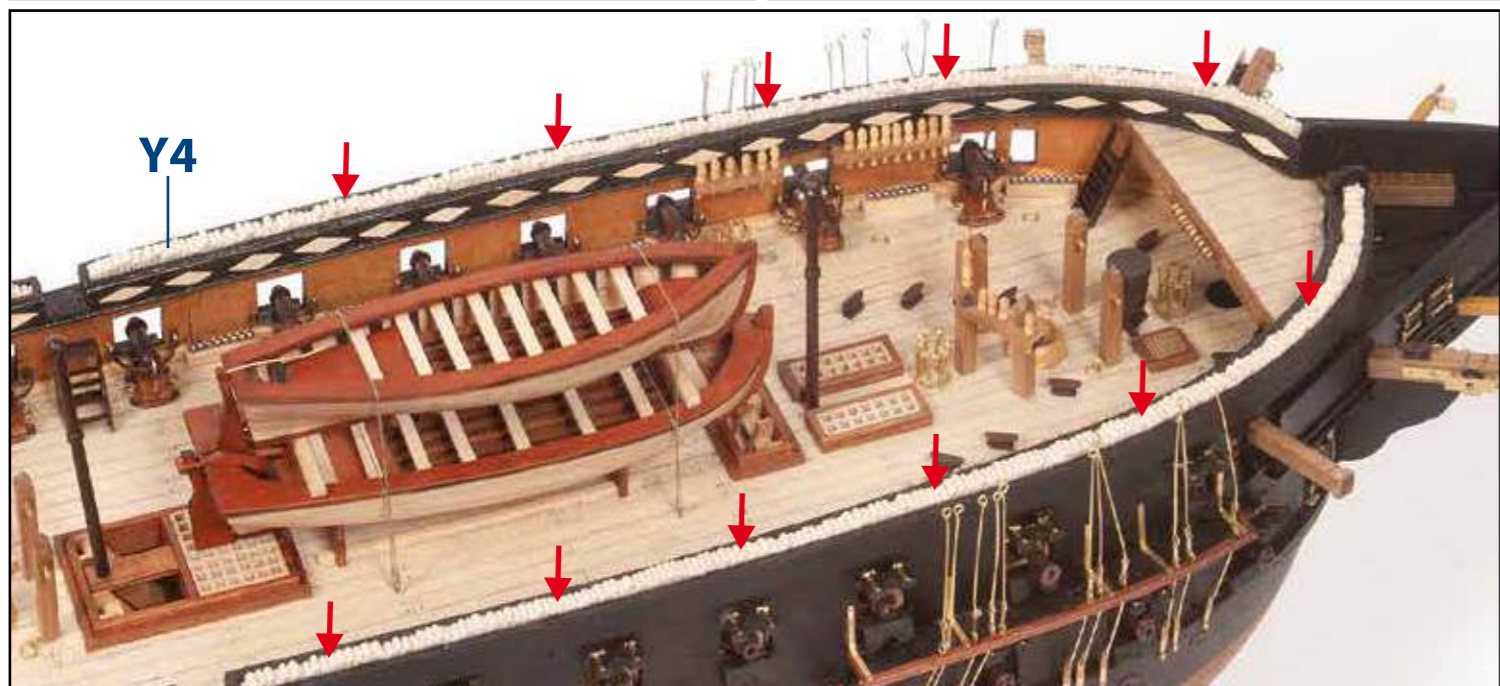
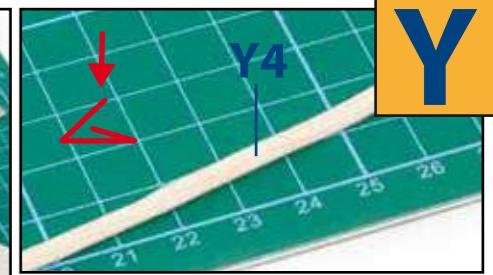
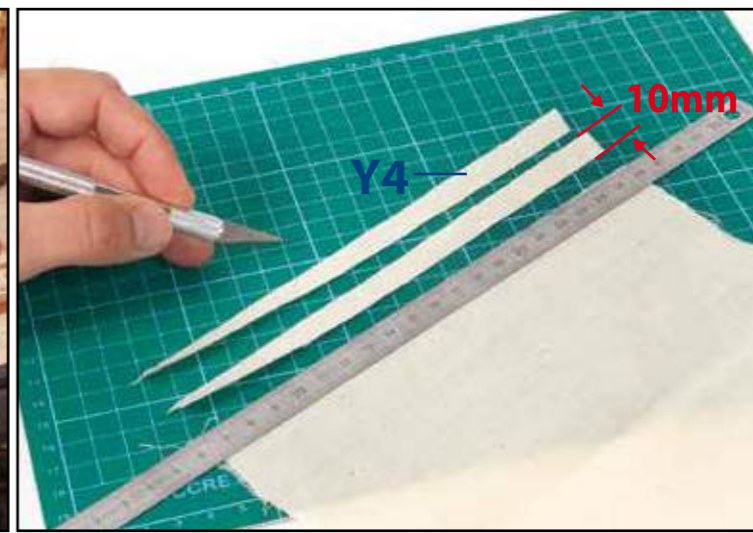
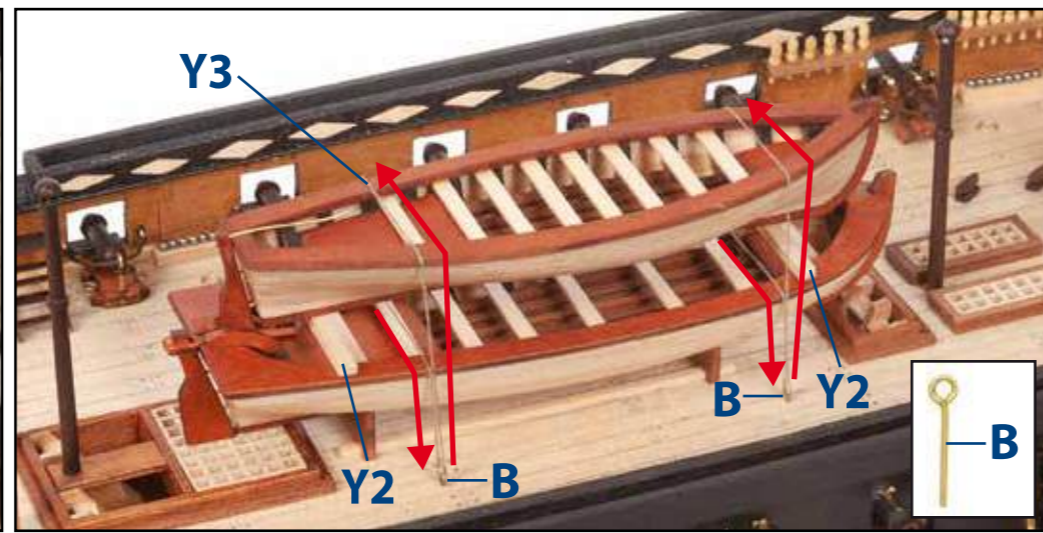
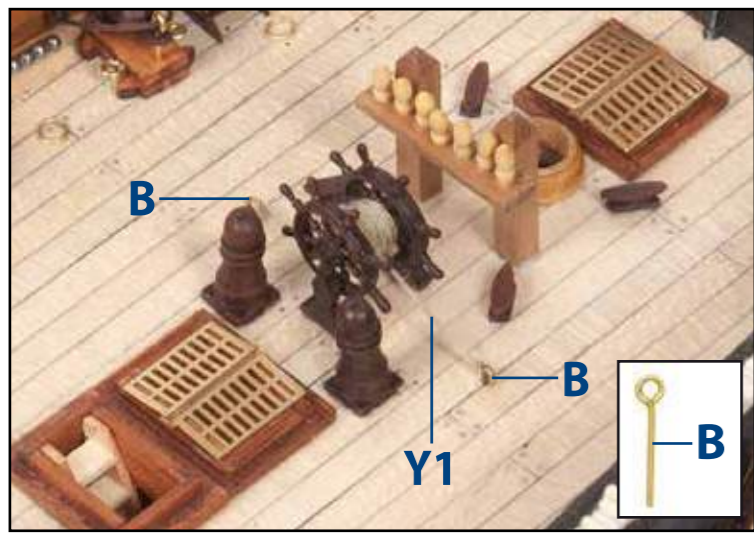

Z

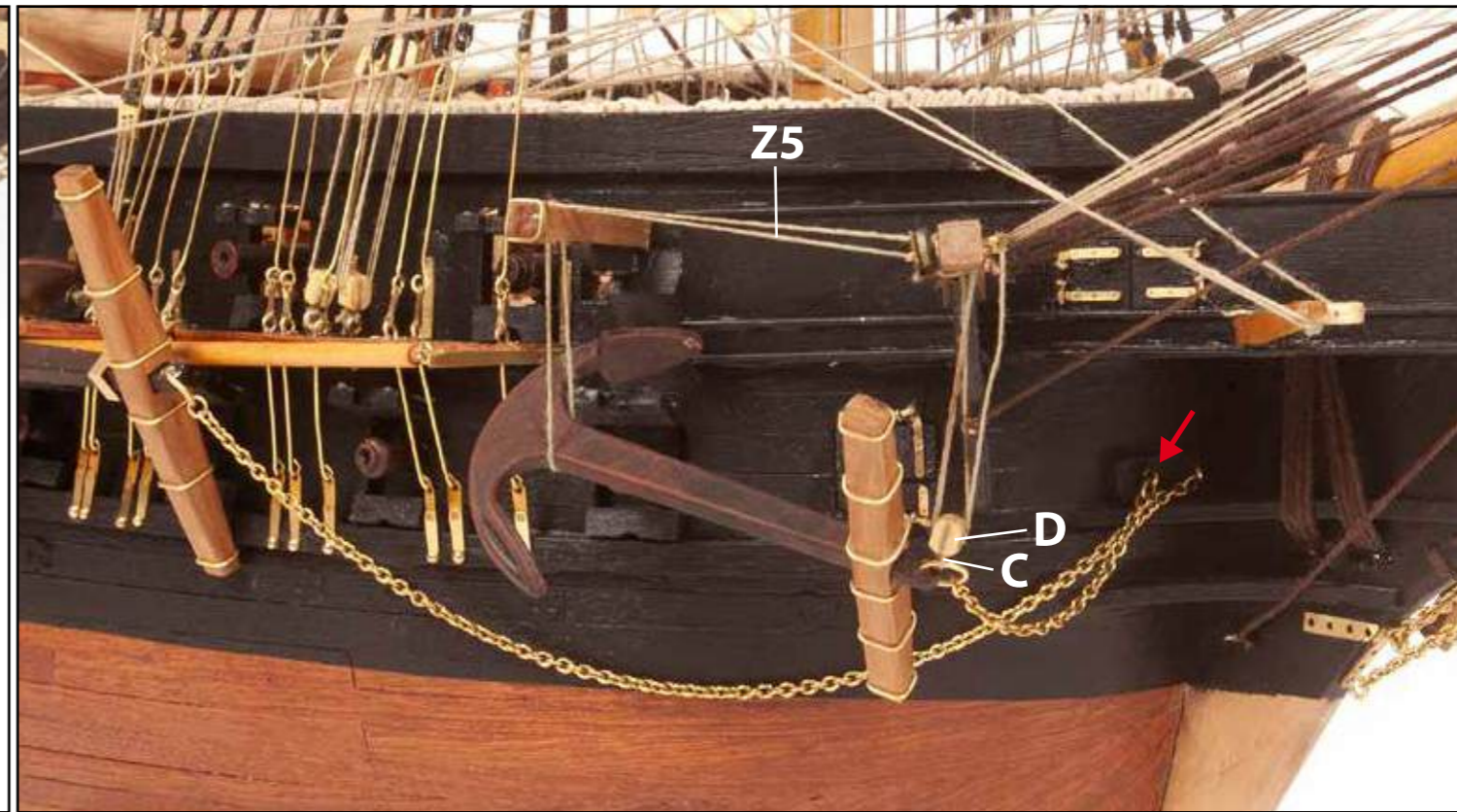
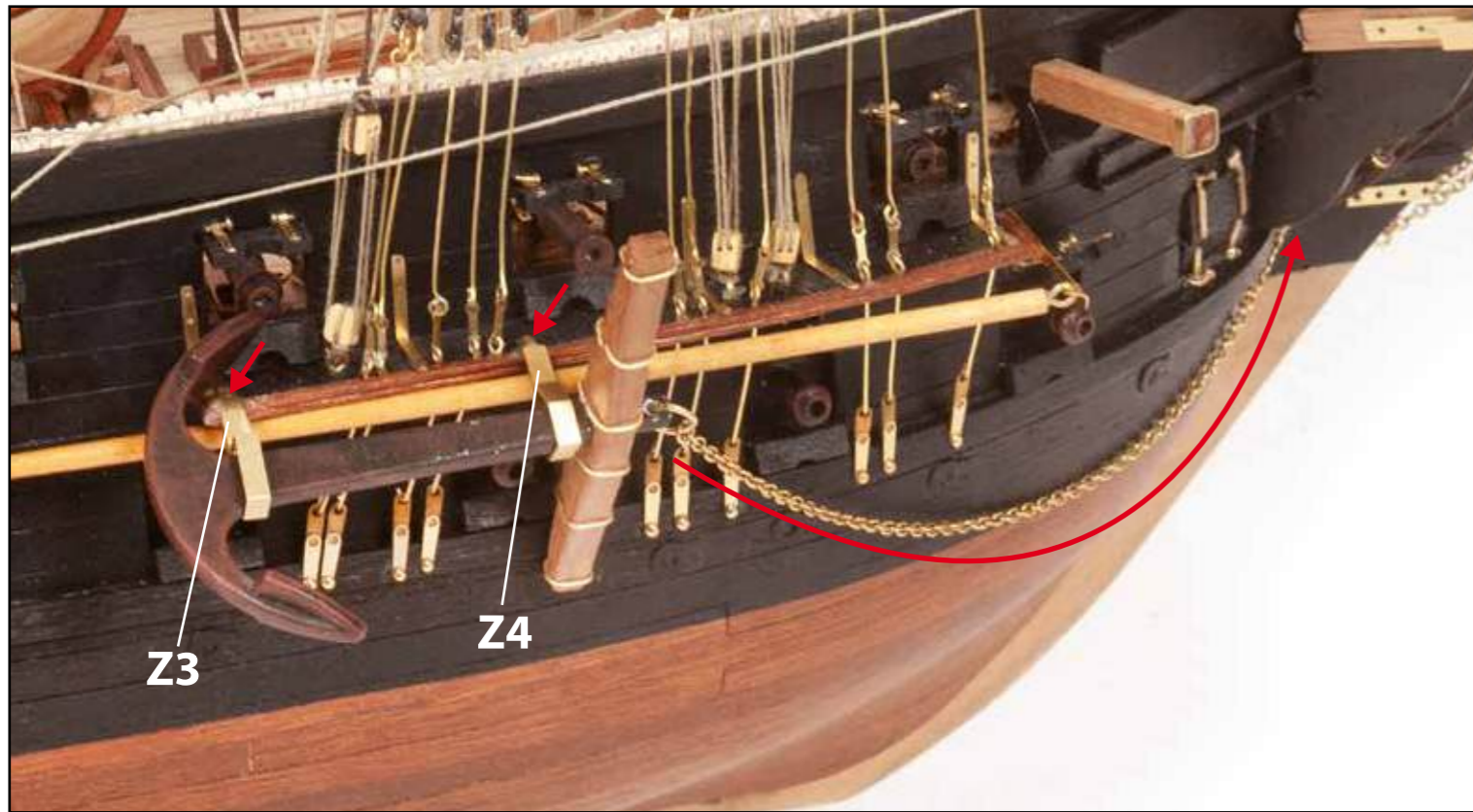
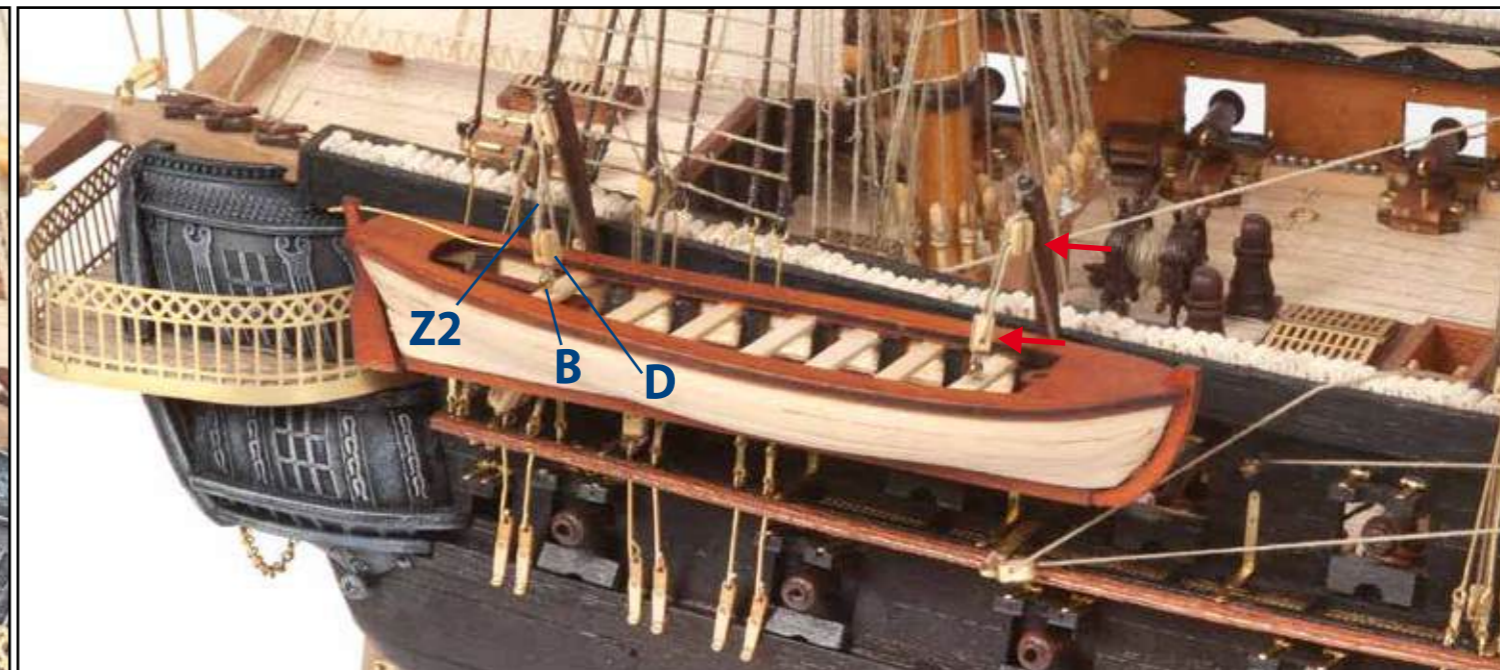
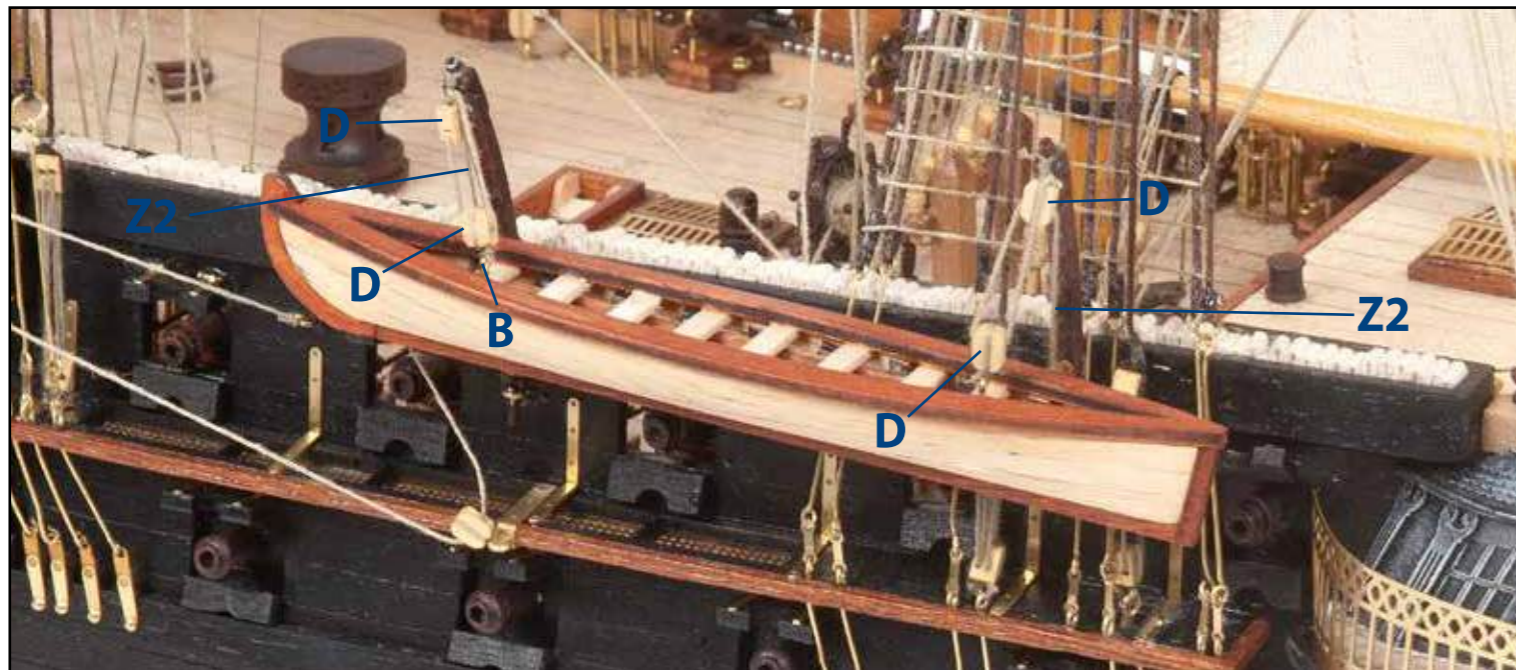
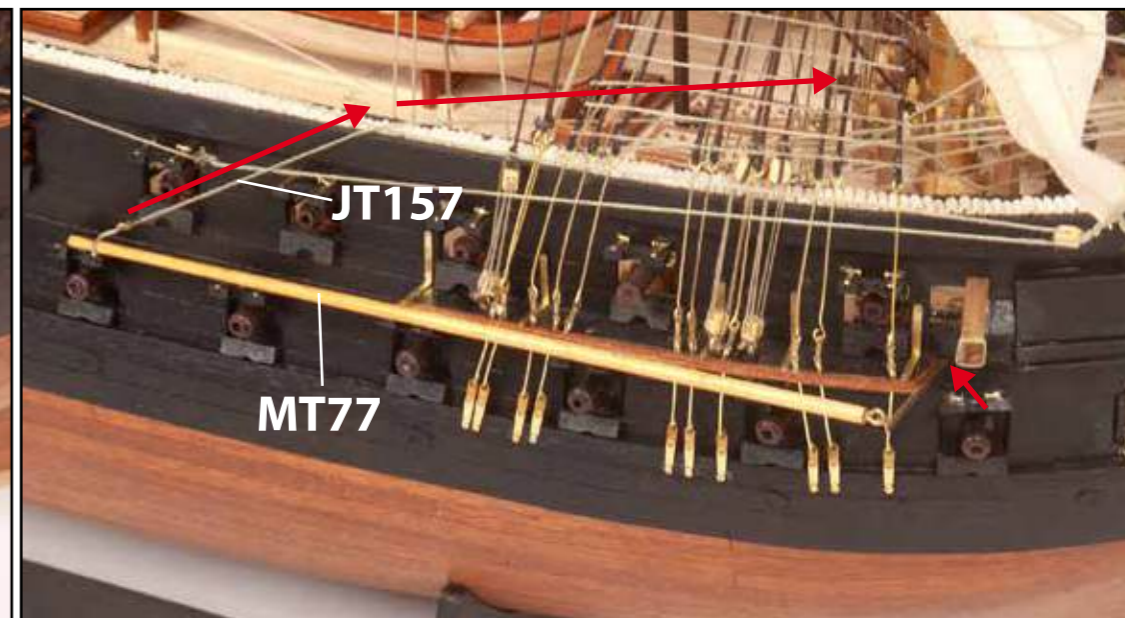
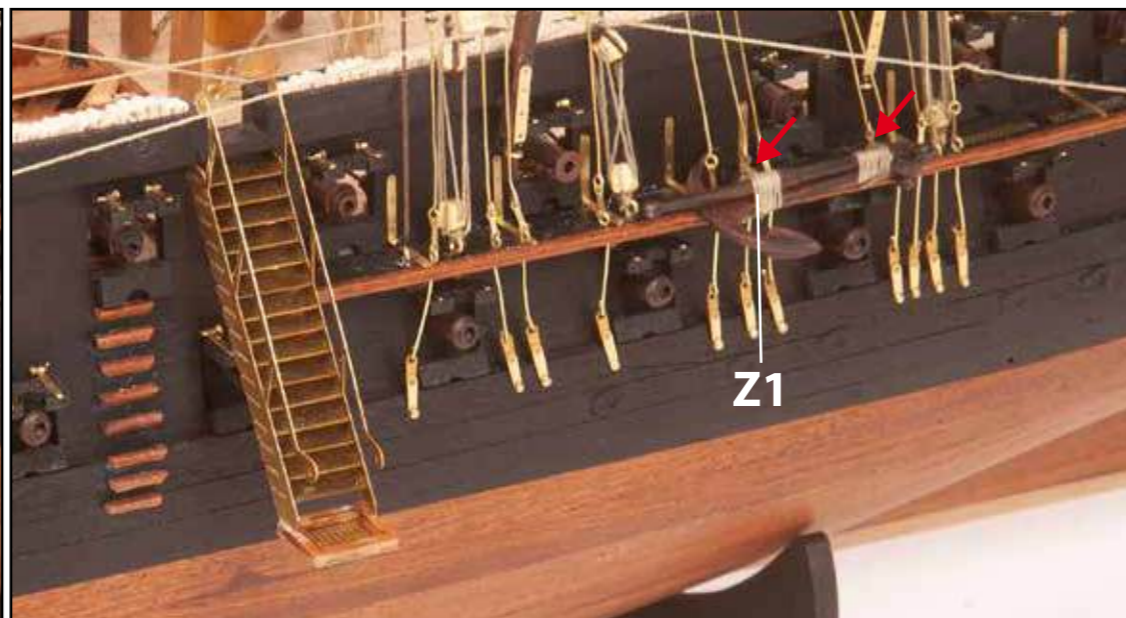
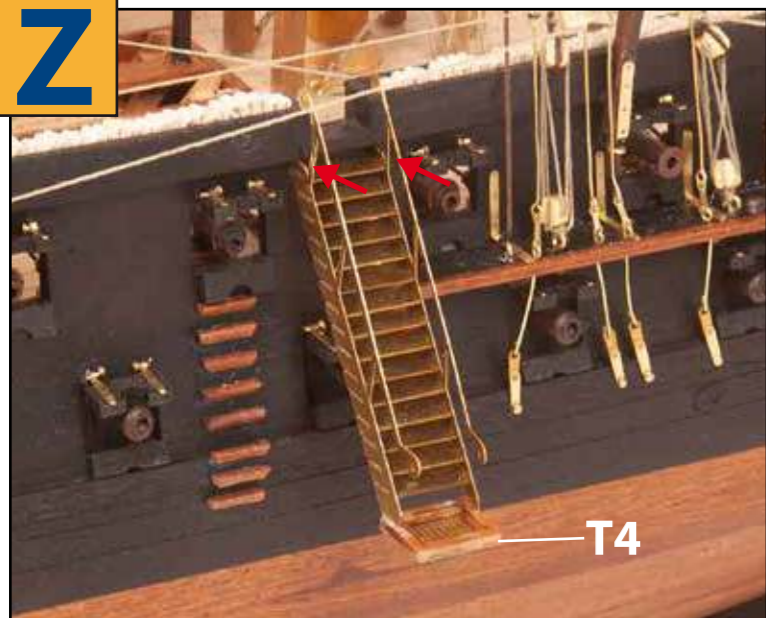

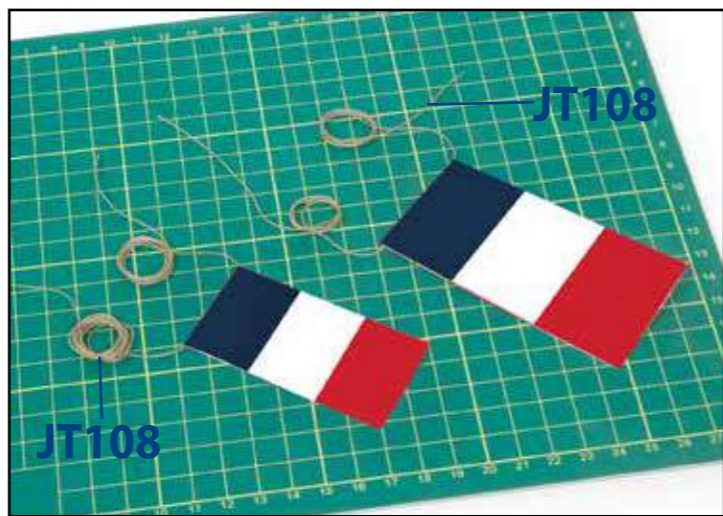
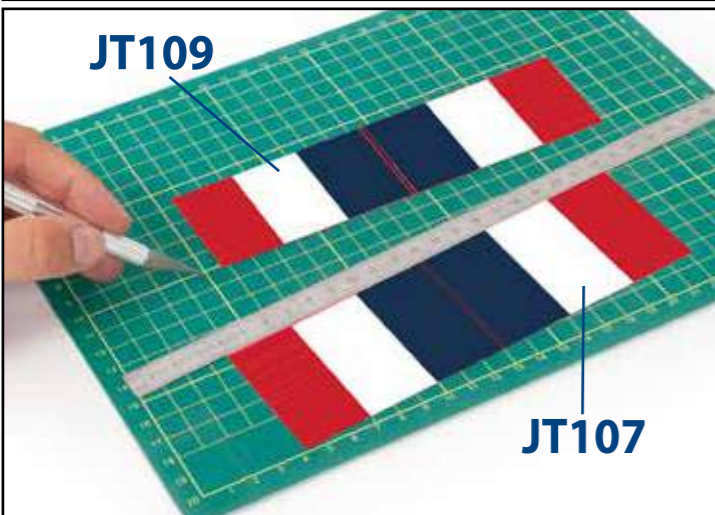



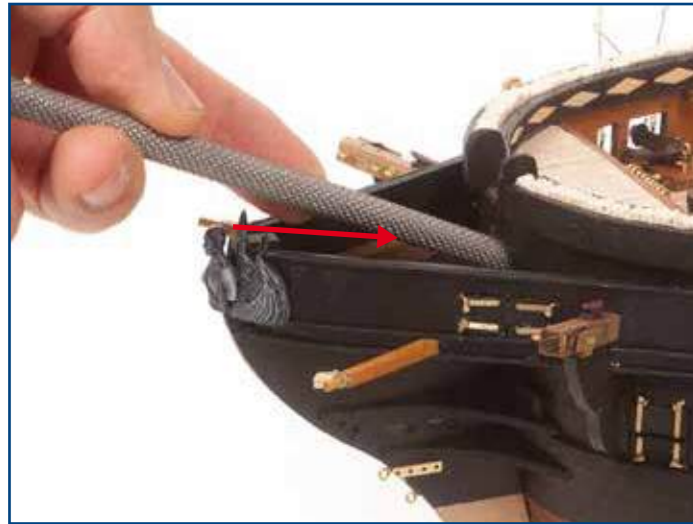
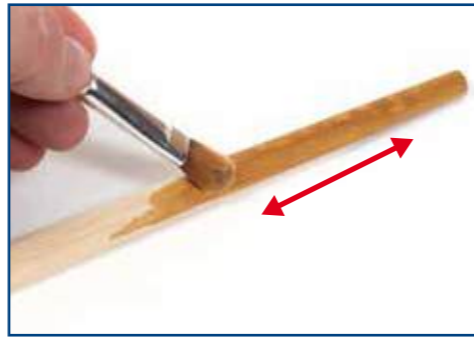
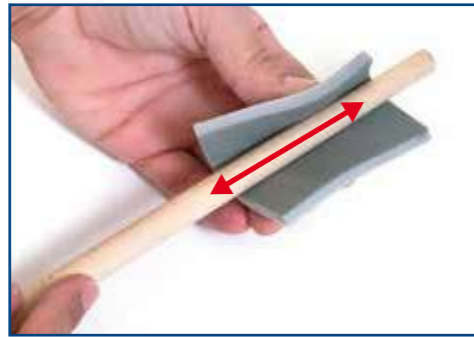
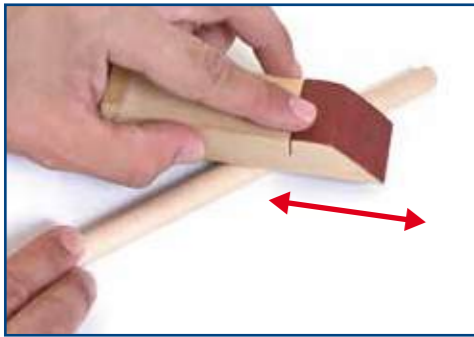

Consultar los planos de mástiles  
Consult the masts drawings  
Consulte os desenhos dos mastros  
Consulter les dessins des mâts  
Konsultieren Sie die Mastenzeichnungen  
Обратитесь к рисункам мачты  
Consultare i disegni degli alberi

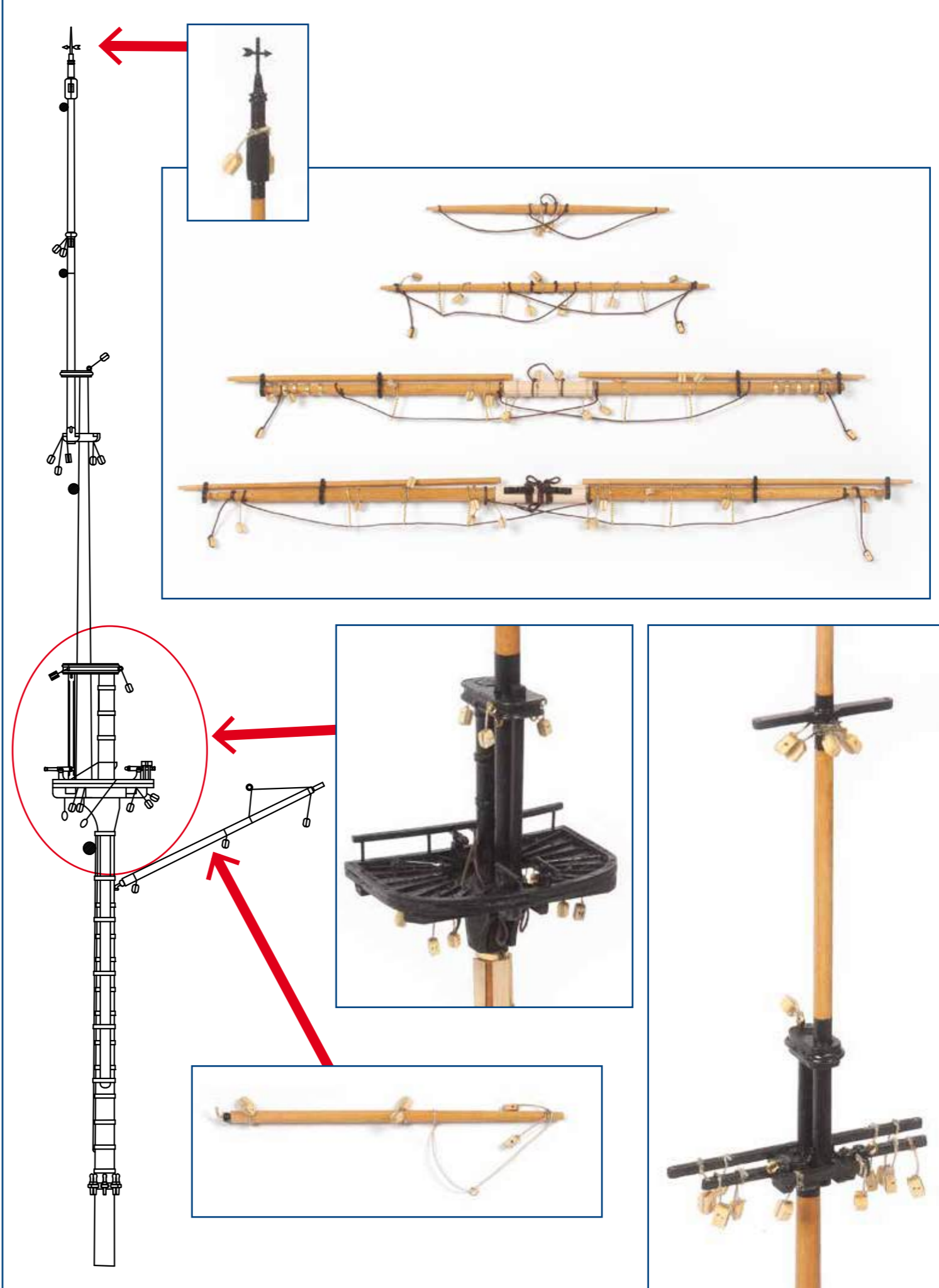
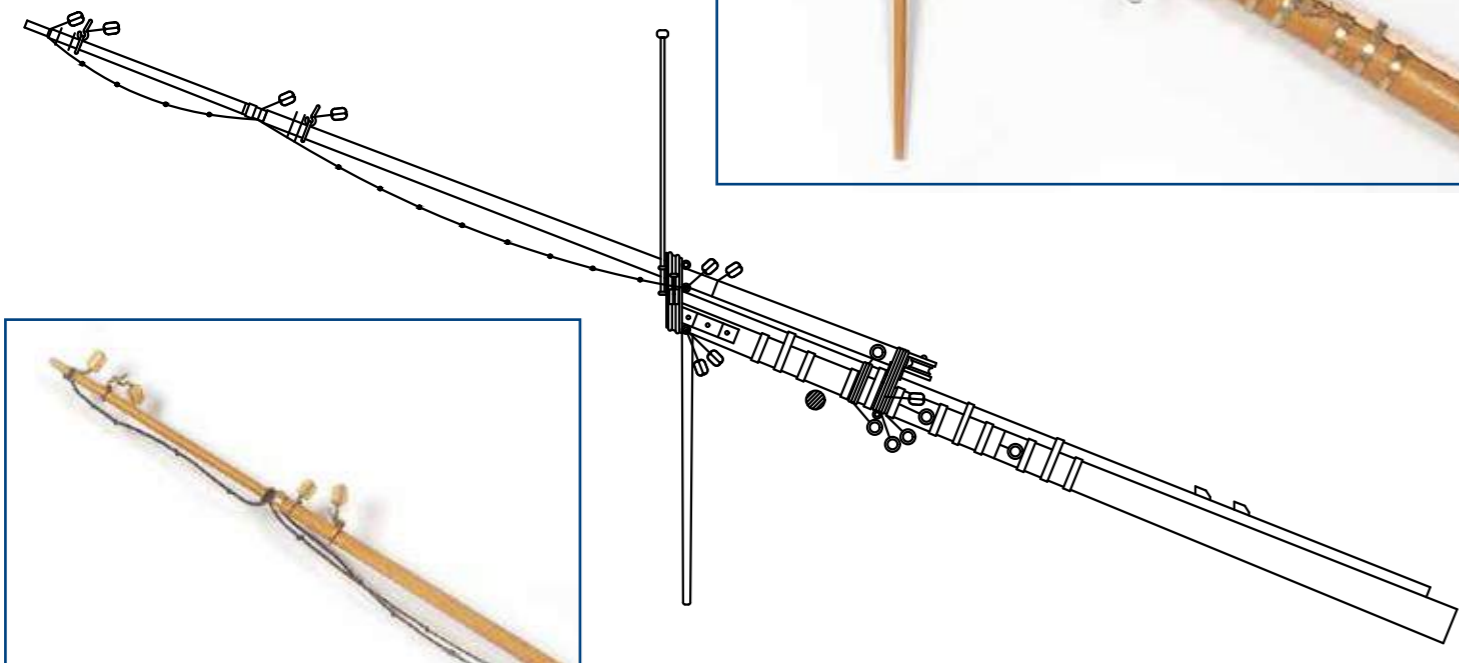

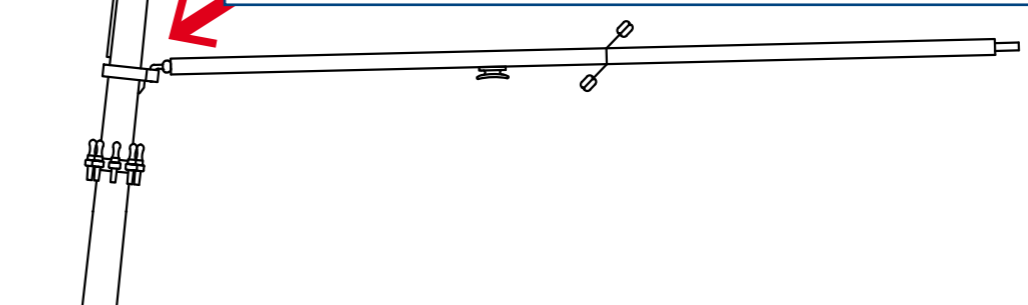
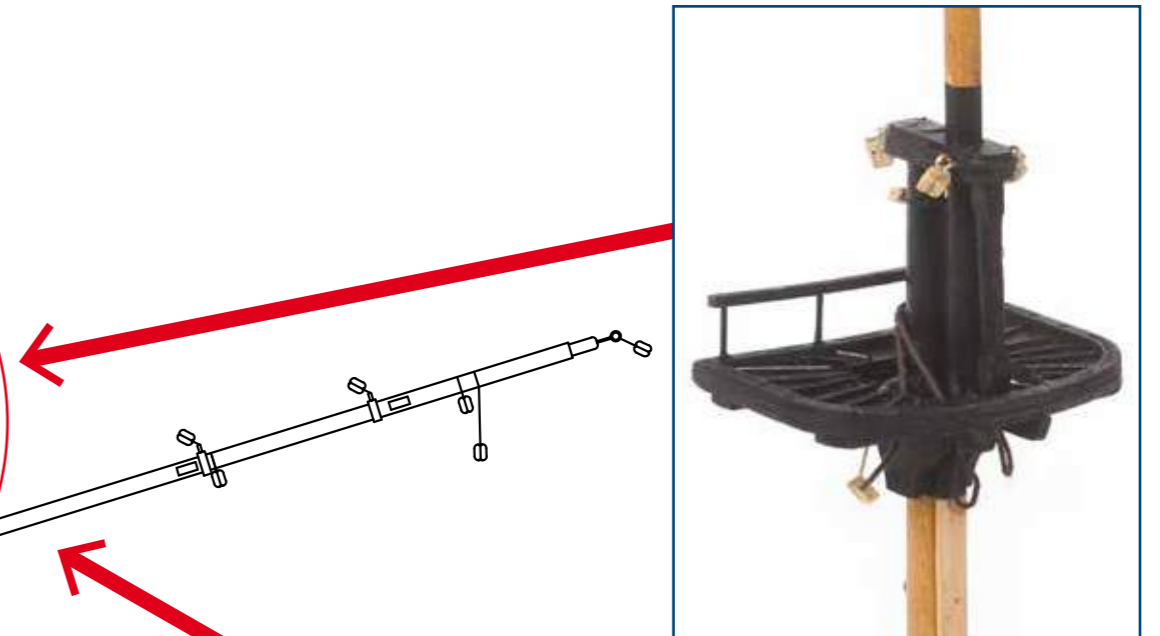
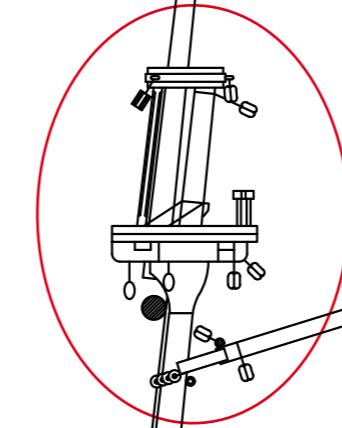
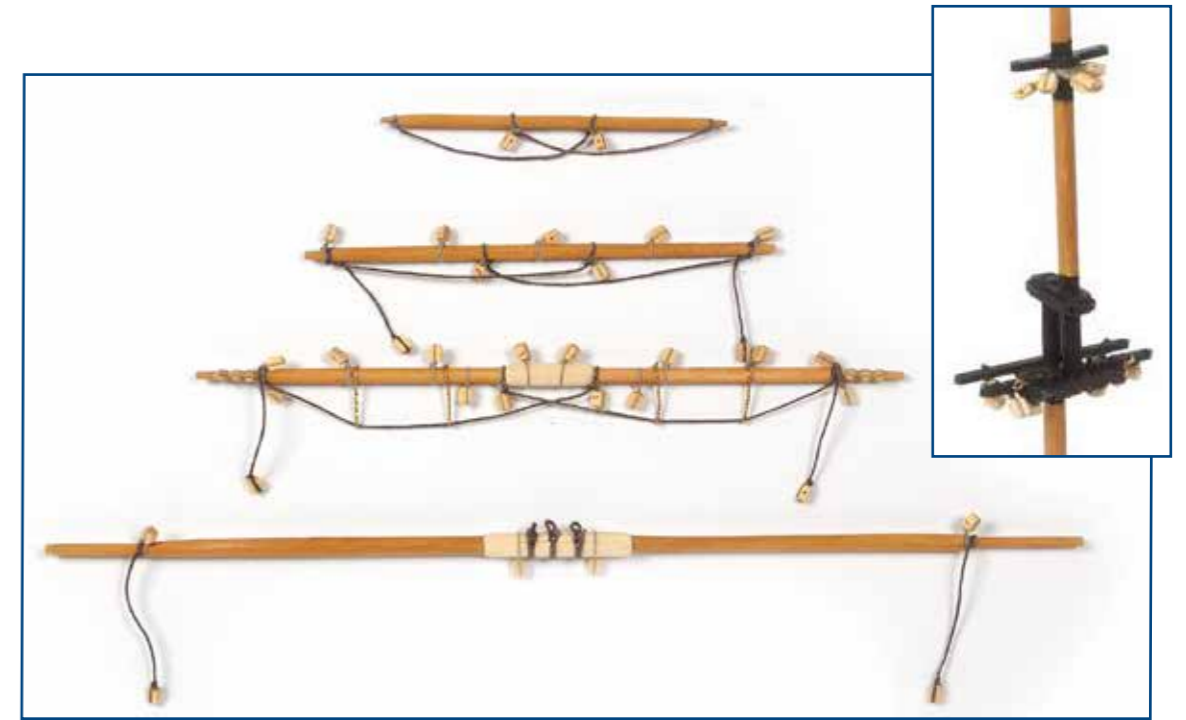
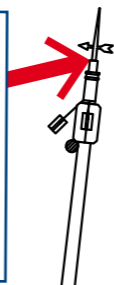
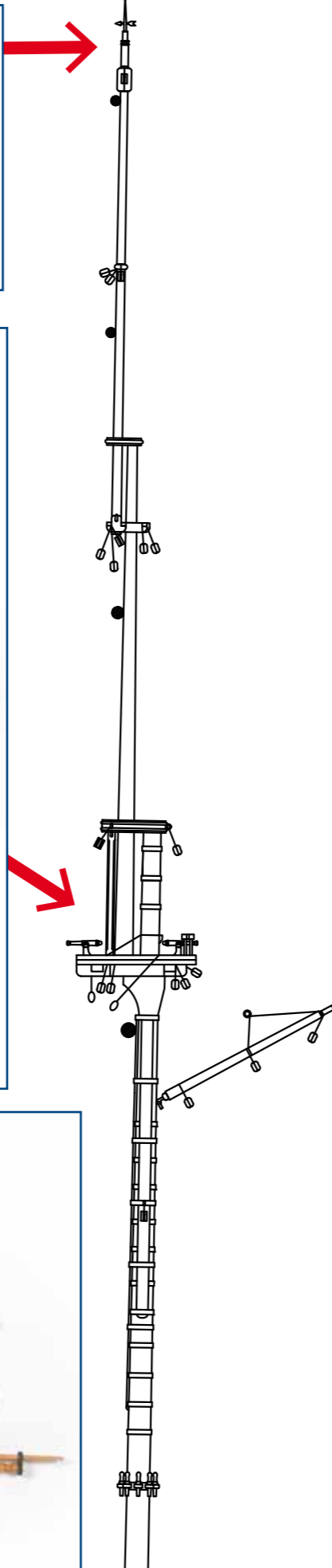
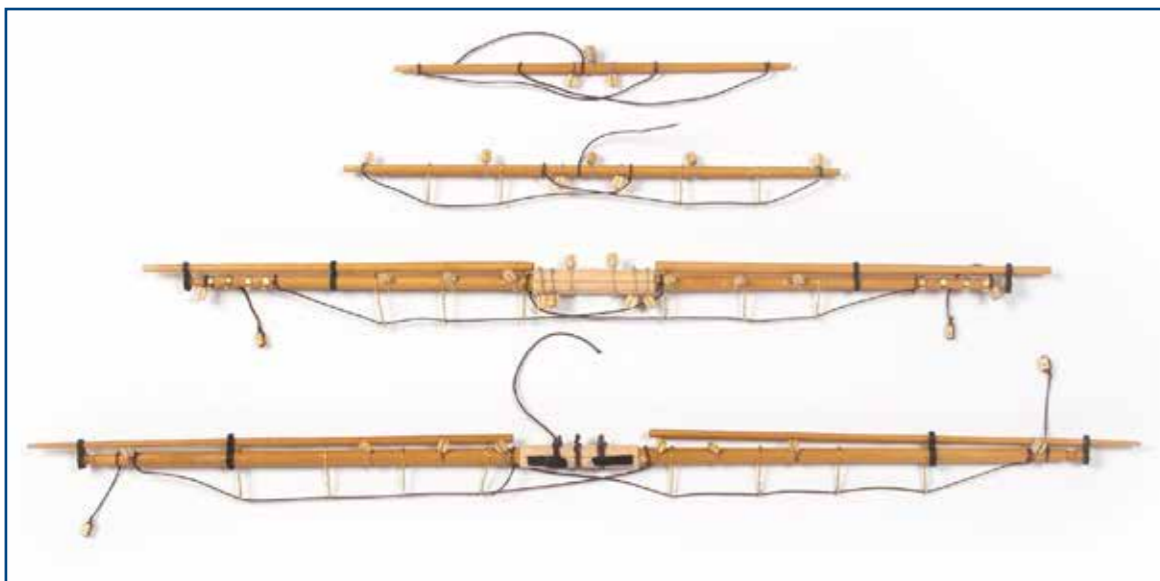

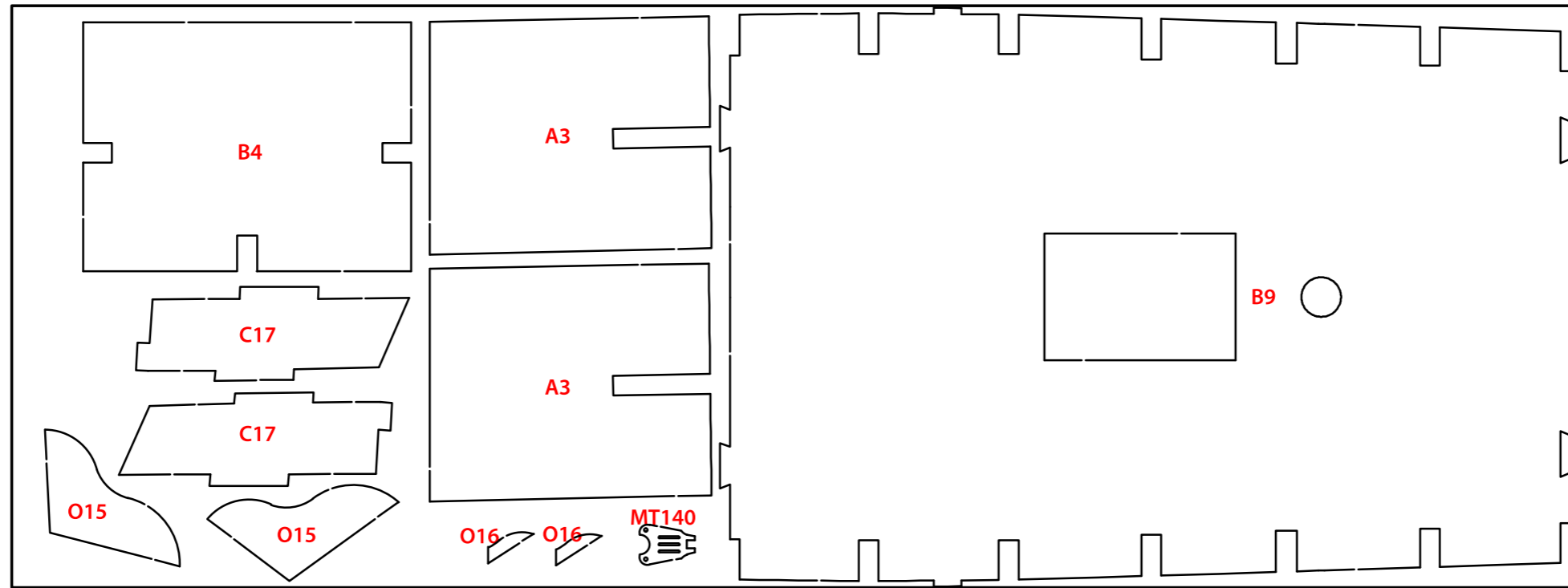

15007-6

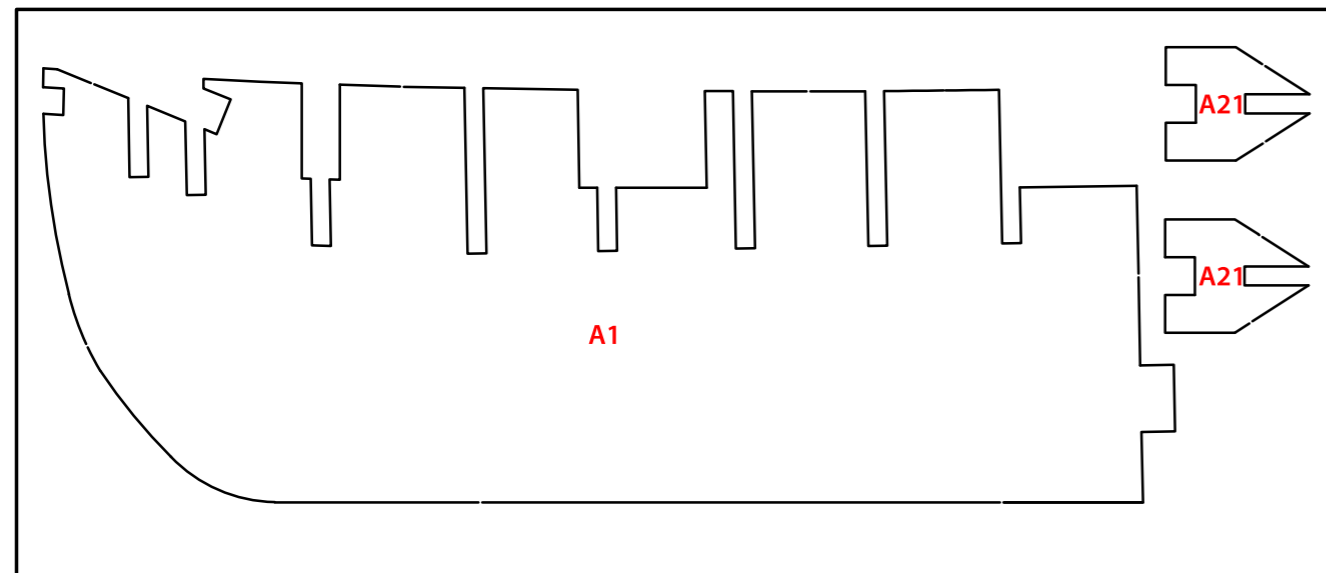

15007-1

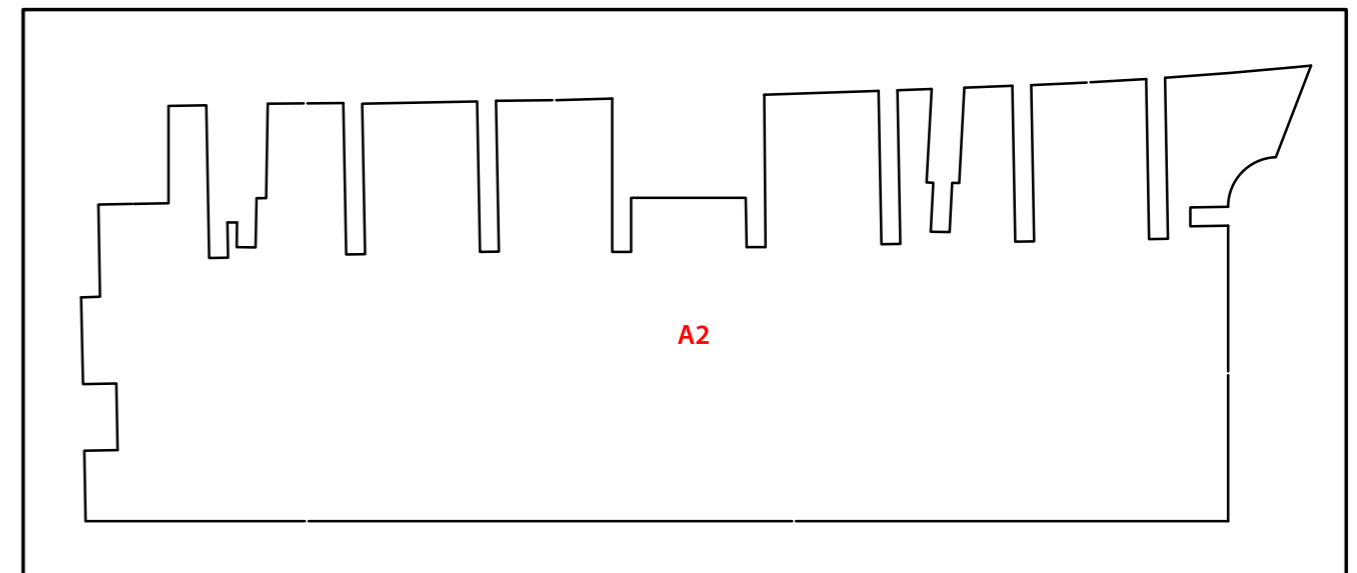

15007-2



# IP

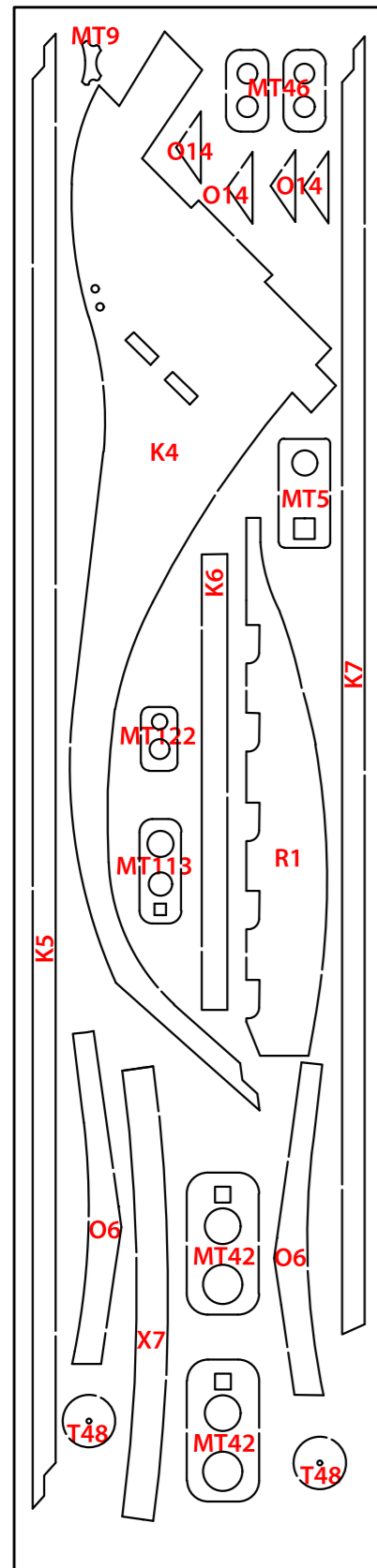

15007-10

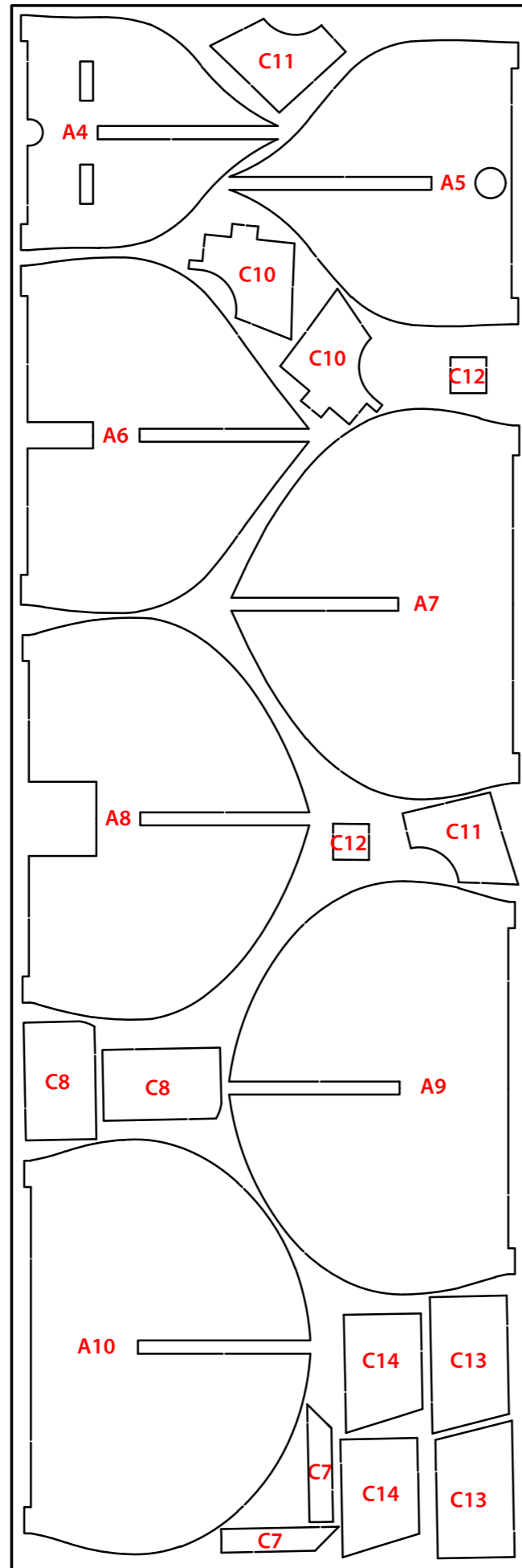

15007-3

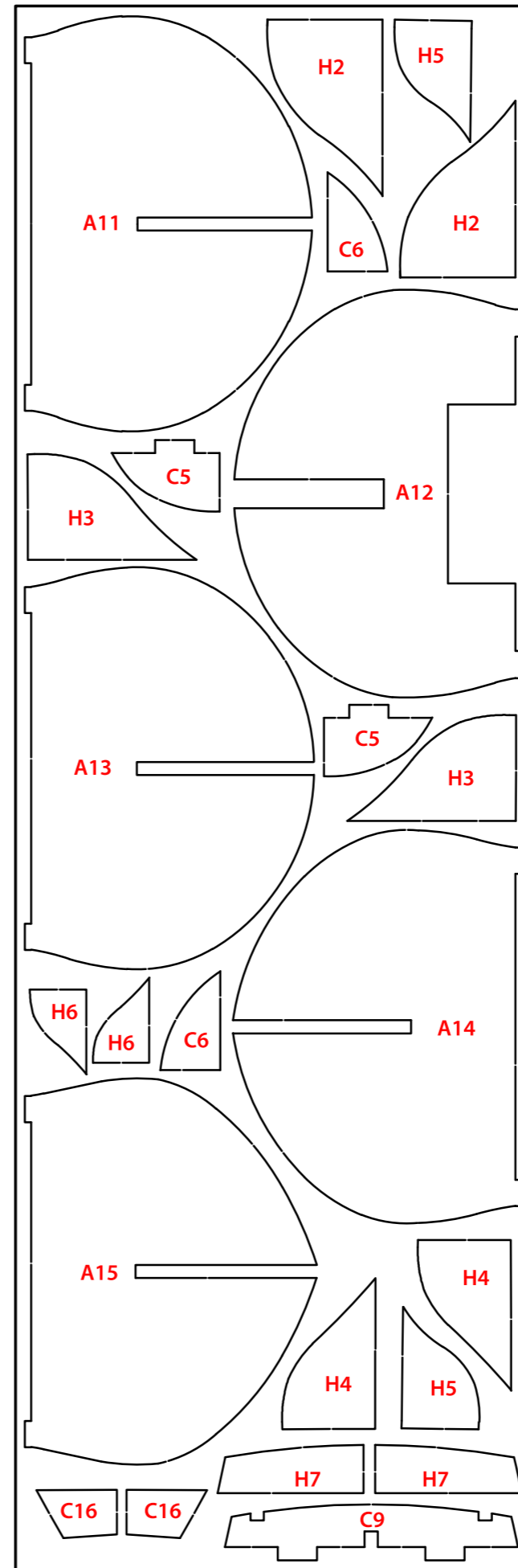

15007-4

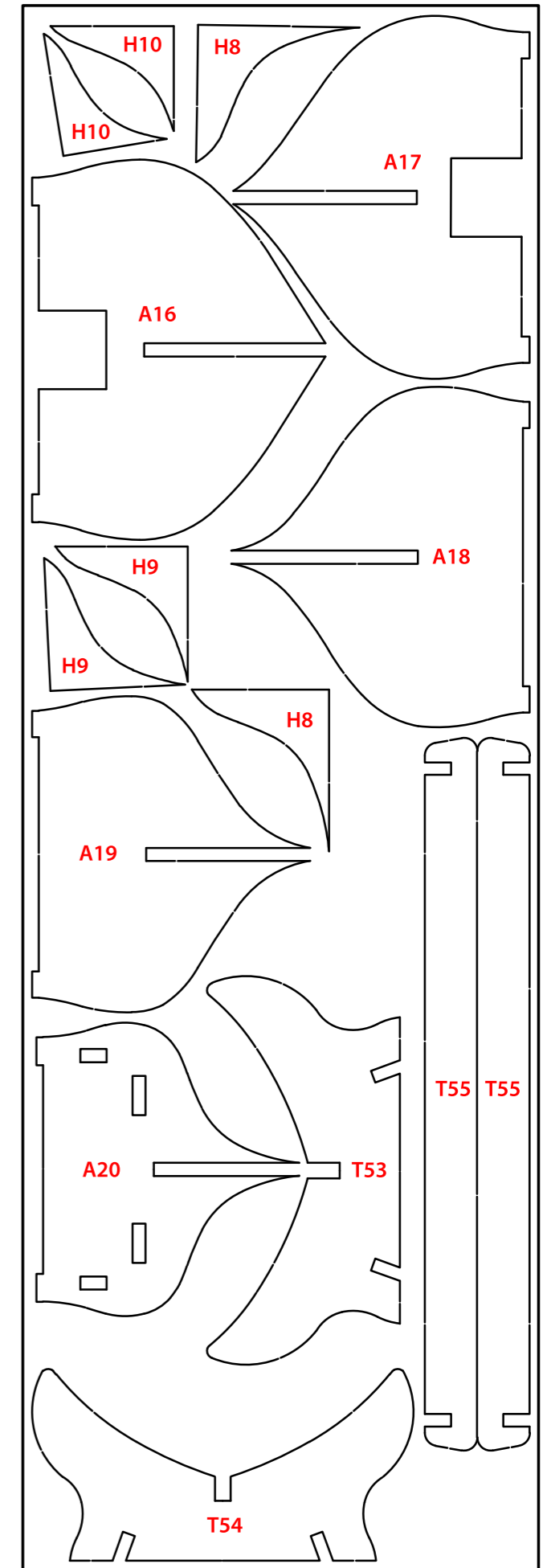

15007-5



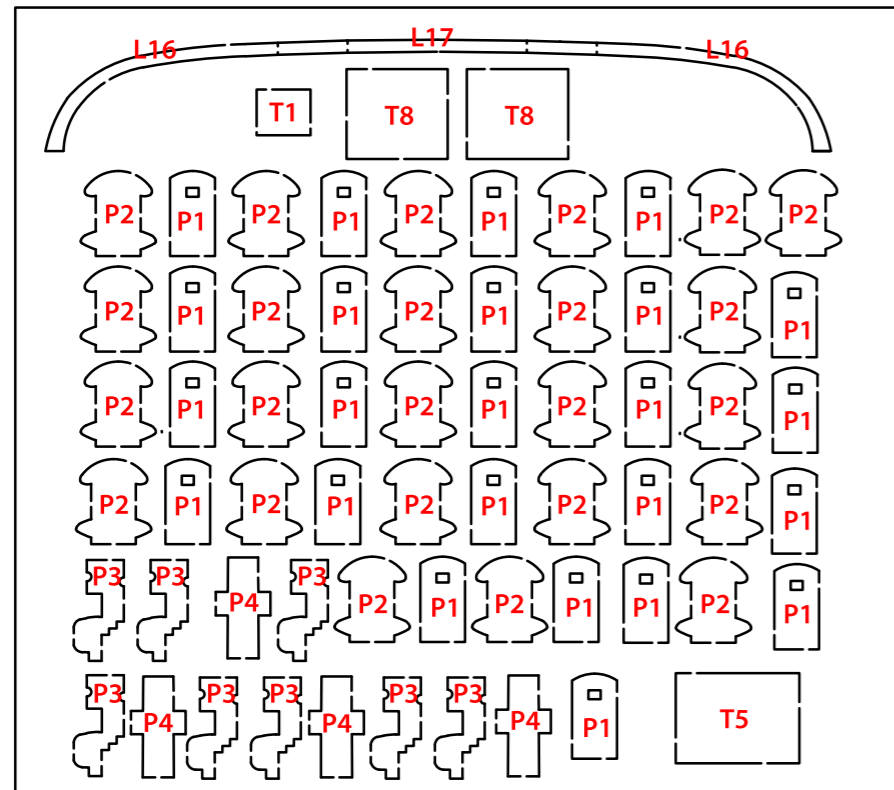

15007-12

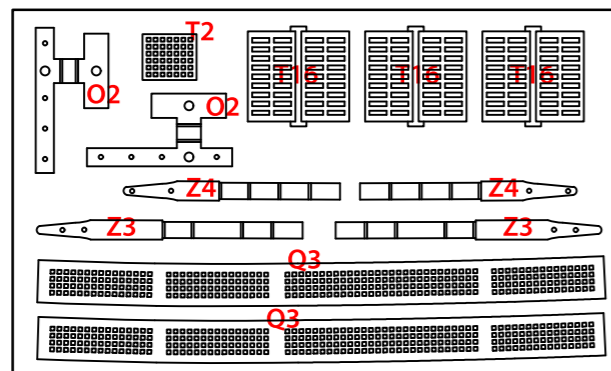

15007-15

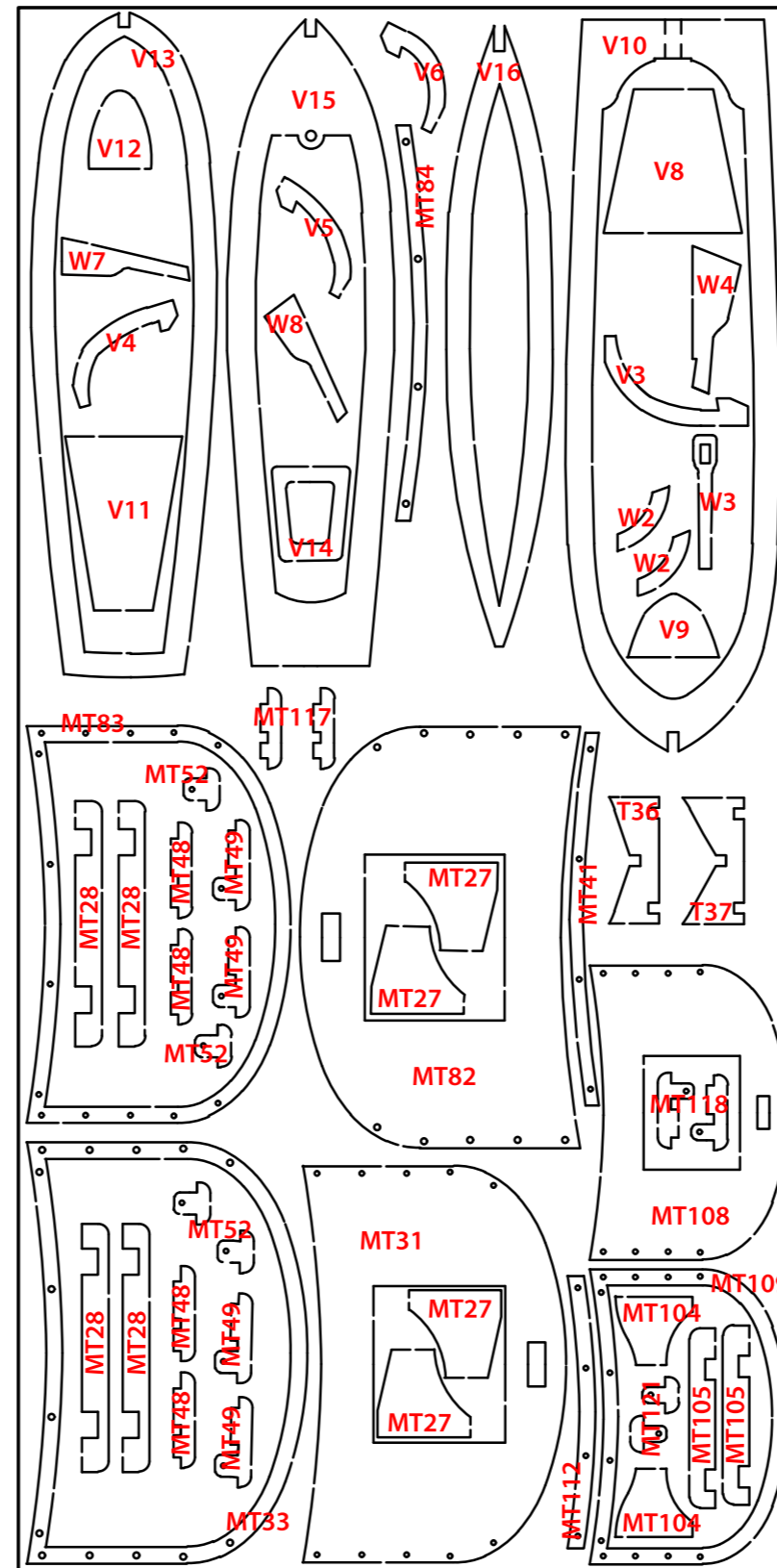

15007-13

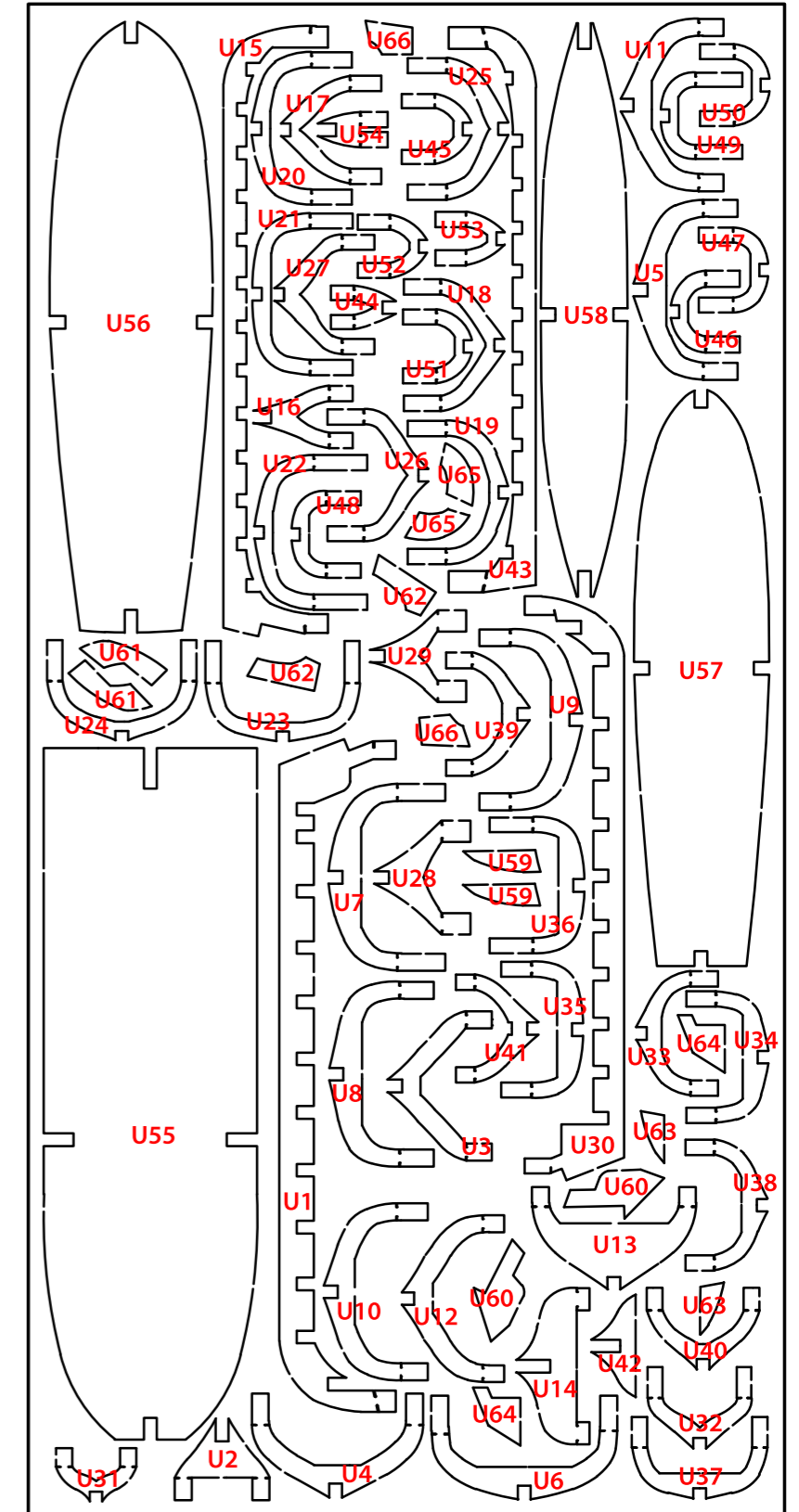

15007-14

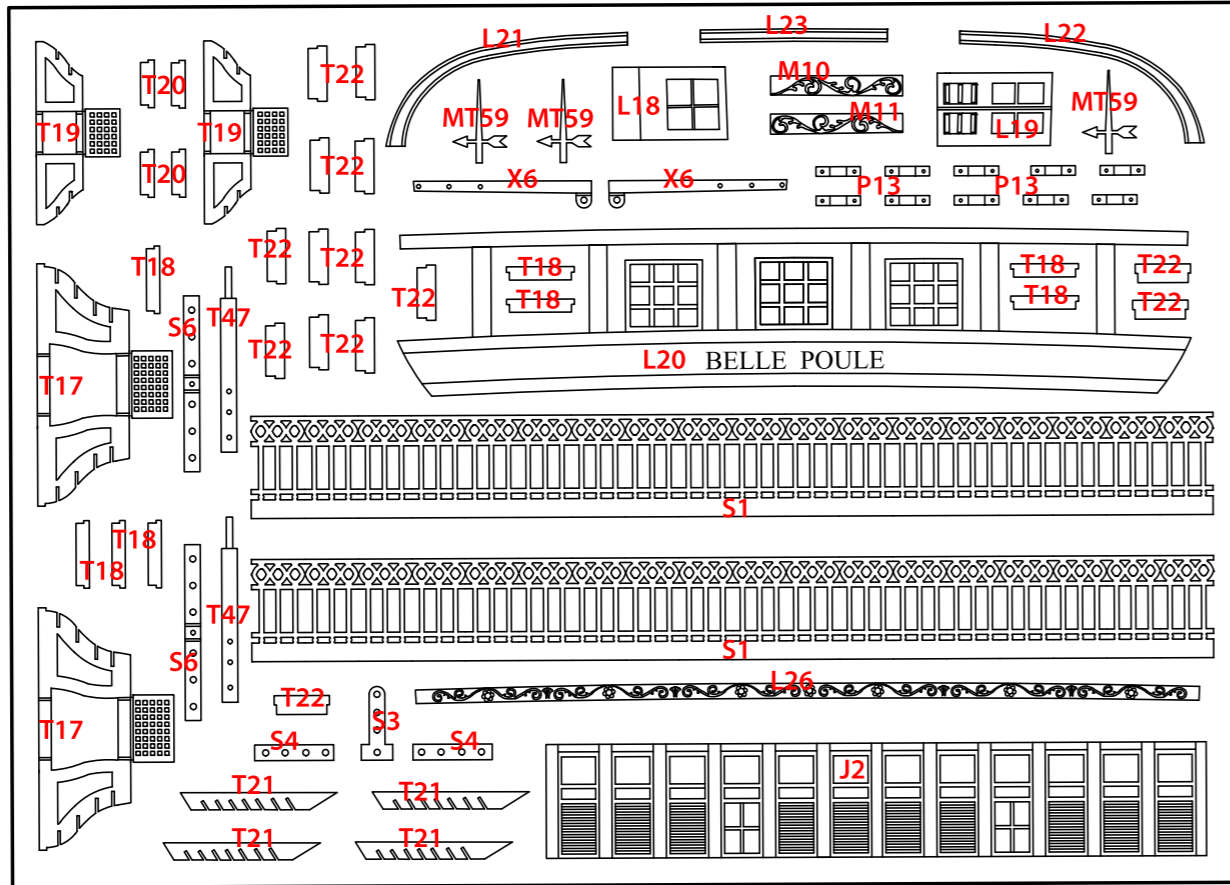

15005-16

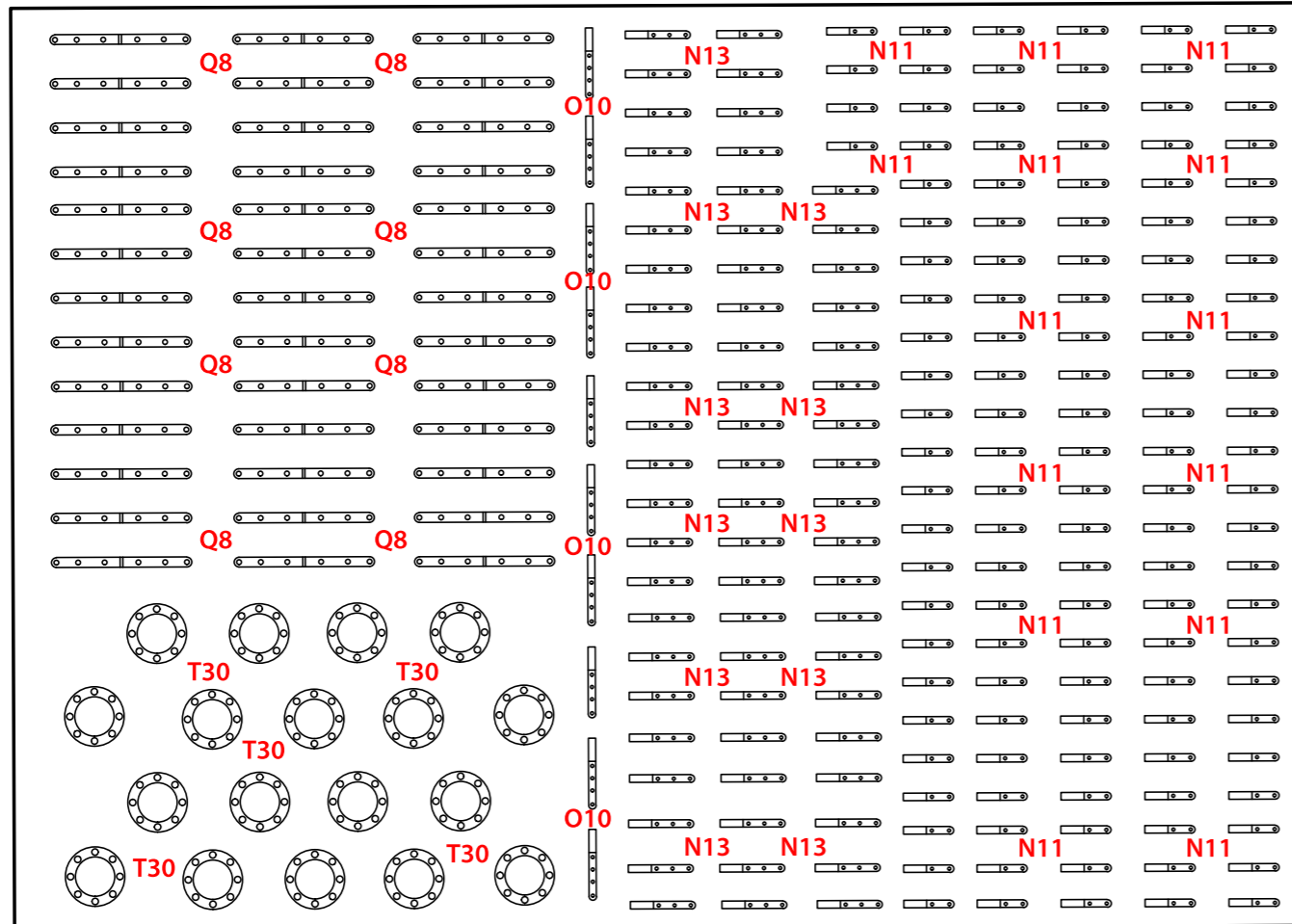

15007-17

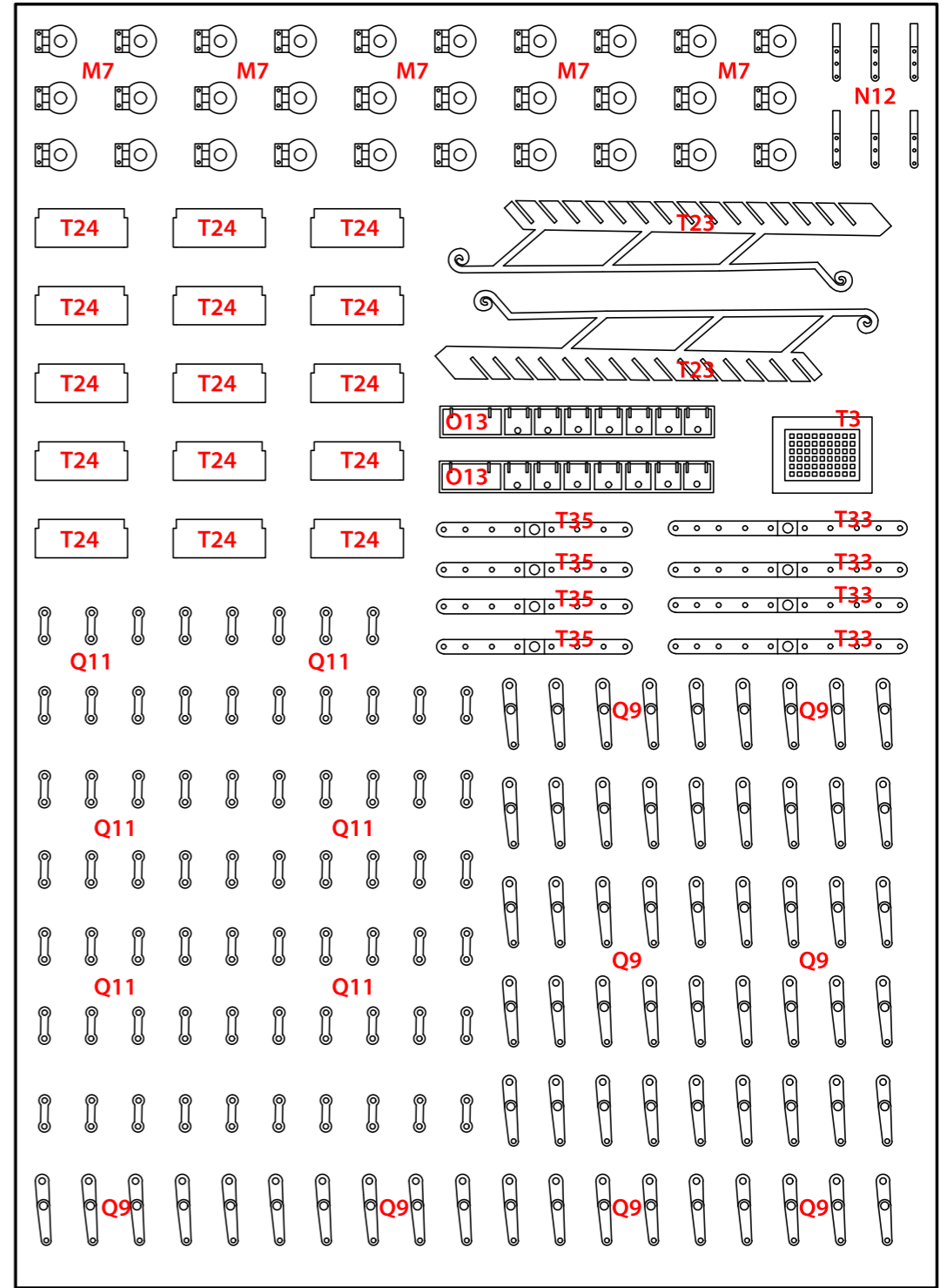

15007-18

# La Belle Poule

PL-01

OCCRE

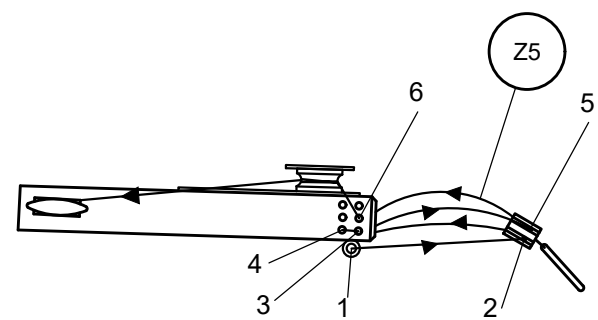
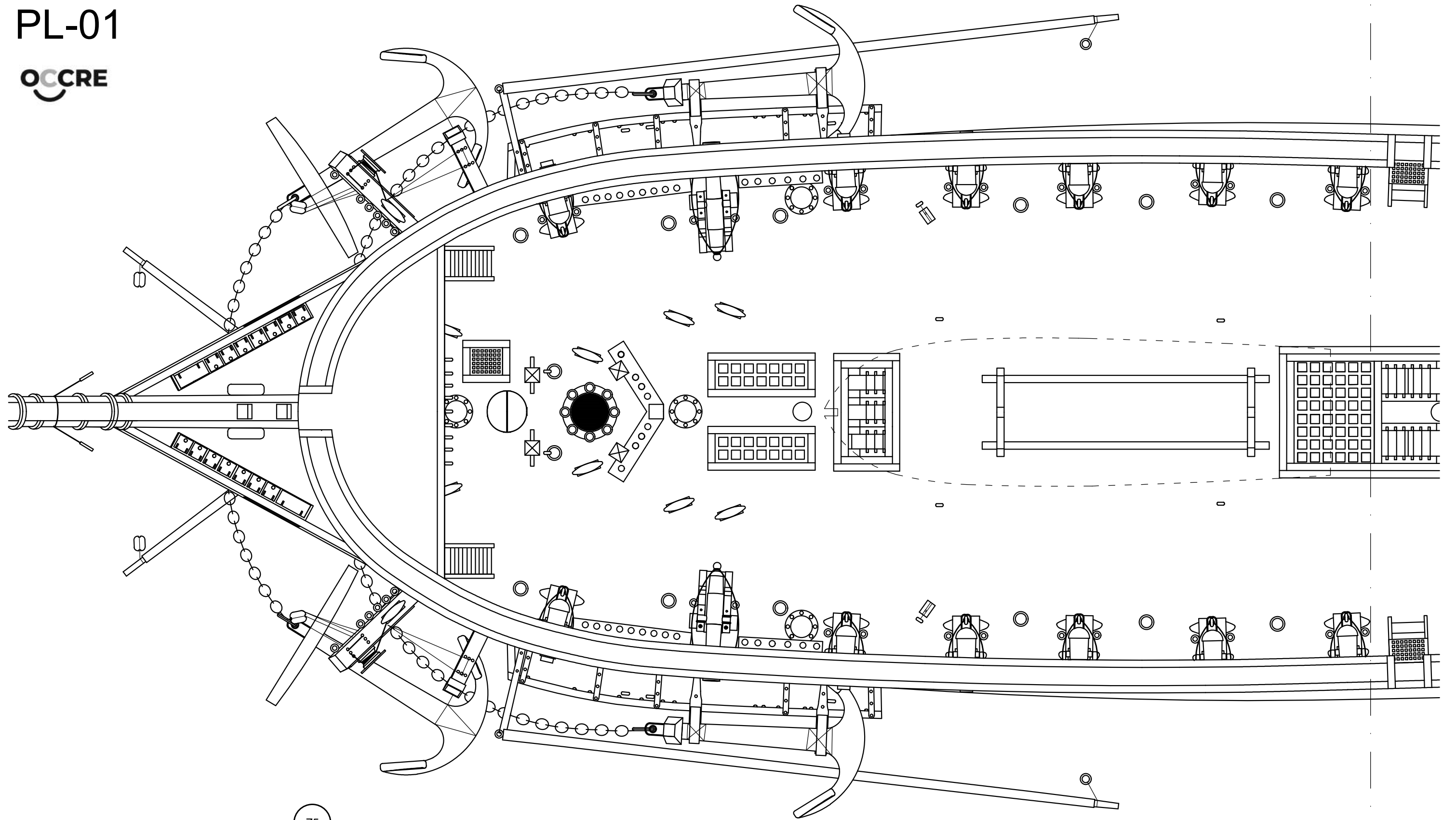

Scale 1/1



# La Belle Poule

PL-01

OCCRE

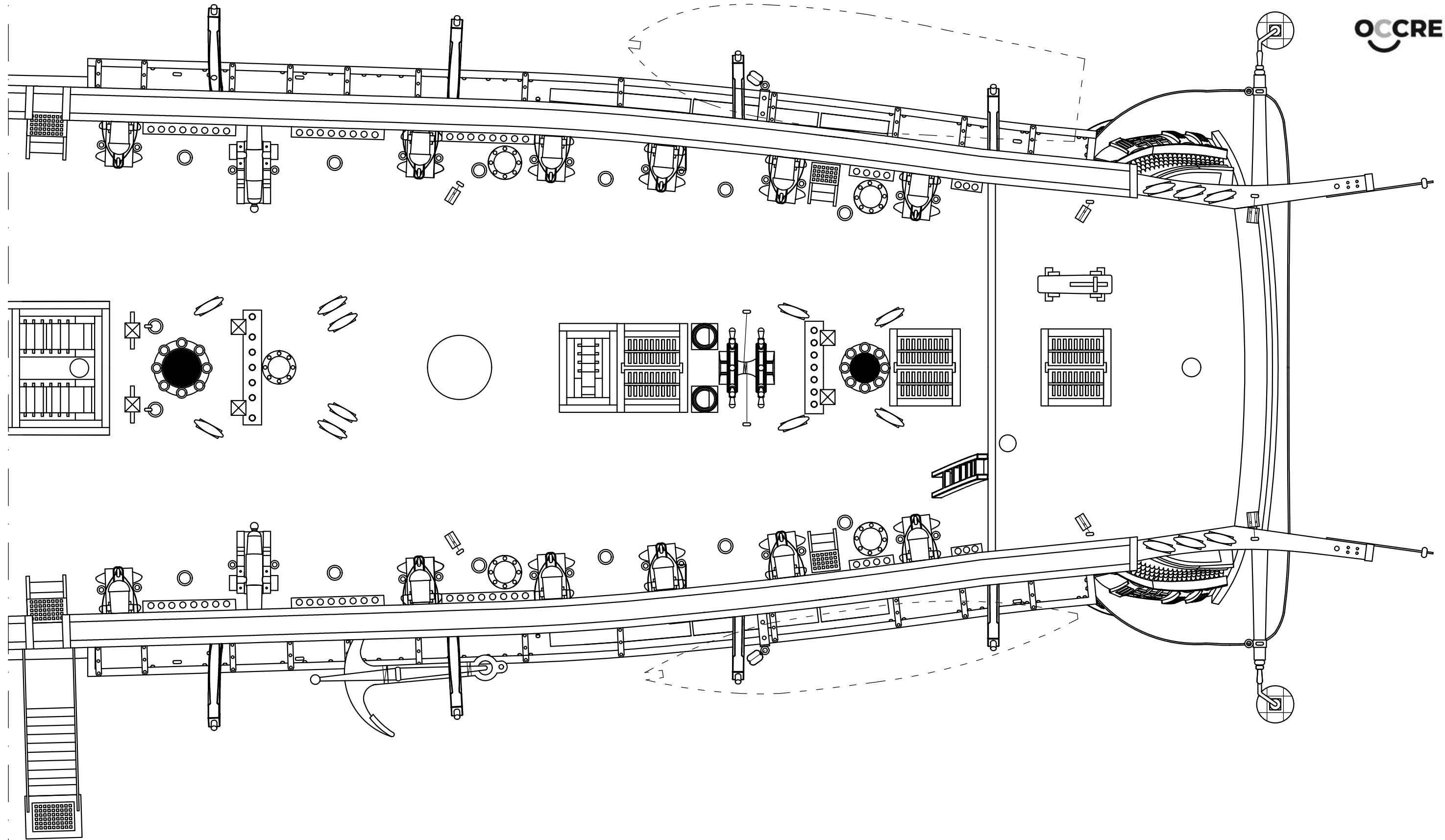

Scale 1/1

# La Belle Poule

Bauprés / Bowsprit / Beupré  
Bompresso / Bugspriet

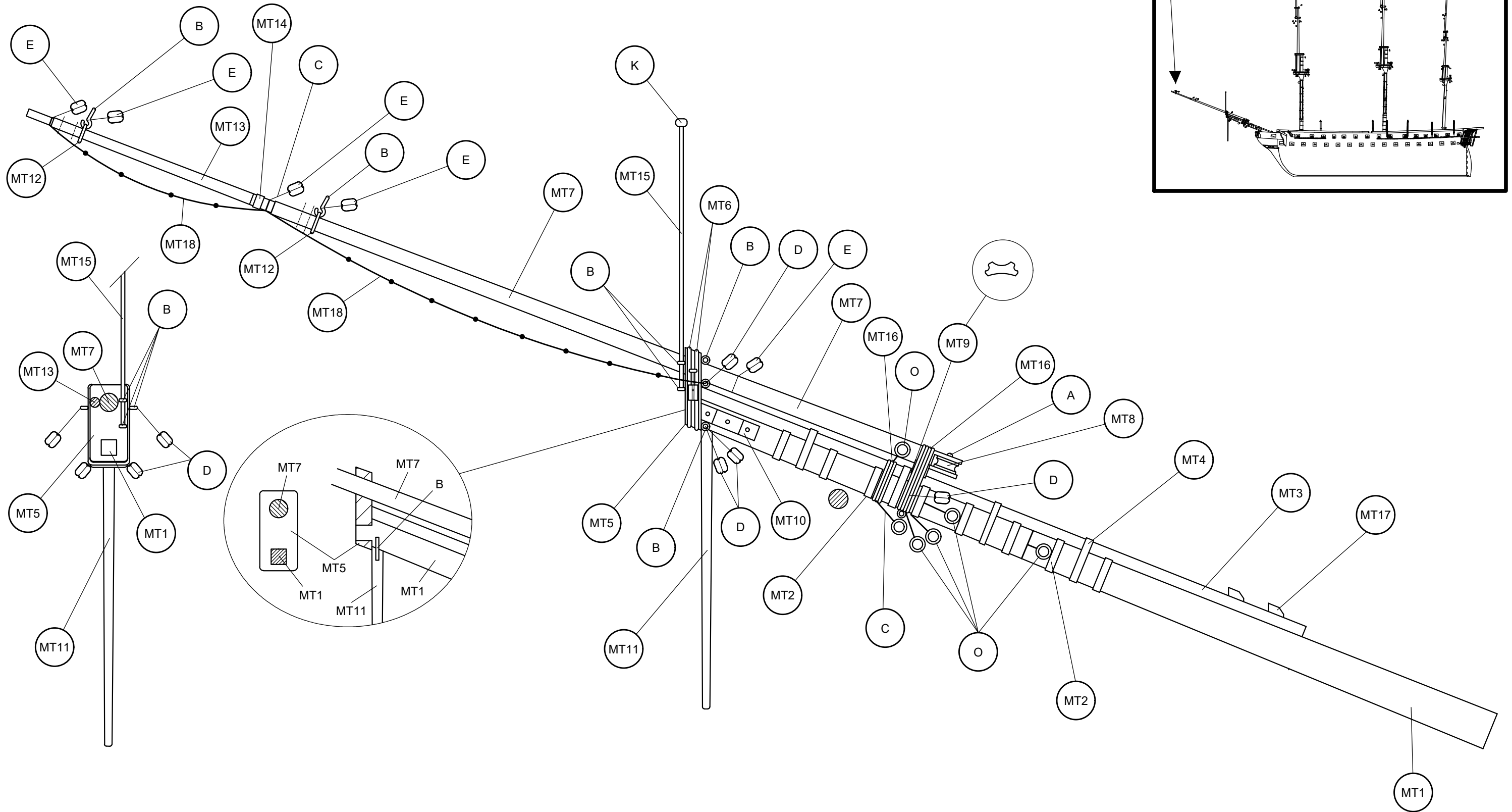
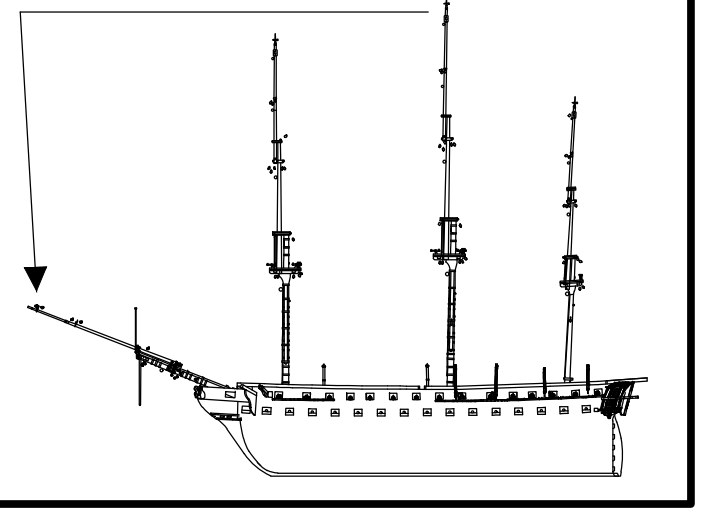

A	B	D	E	F	H	J	K	
Punta	Cáncamo	Moton	Cuadernal	Vigota	Anilla	Cabilla	Vertello	Anilla
Pins	Eyebolts	Blocks	Double blocks	Dead eyes	Rings	Belaying Pins	Trucks	Rings
Punte	Caviglia di ferro ad anello	Bozzello	Pastecca	Bigotta	Anello	Caviglia	Bertocci	Anello
Stifte	Tragöse	Blockrolle	Block	Jungferblock	Öse	Rundeisen	Racktaublöcke	Öse
Pointes	Piton à oeil	Poulie	Poulie double	Cap de mouton	Oeil	Cheville	Pomme de racage	Oeil

Scale 1/1

# La Belle Poule

Bauprés / Bowsprit / Beaupré  
Bompresso / Bugsprit

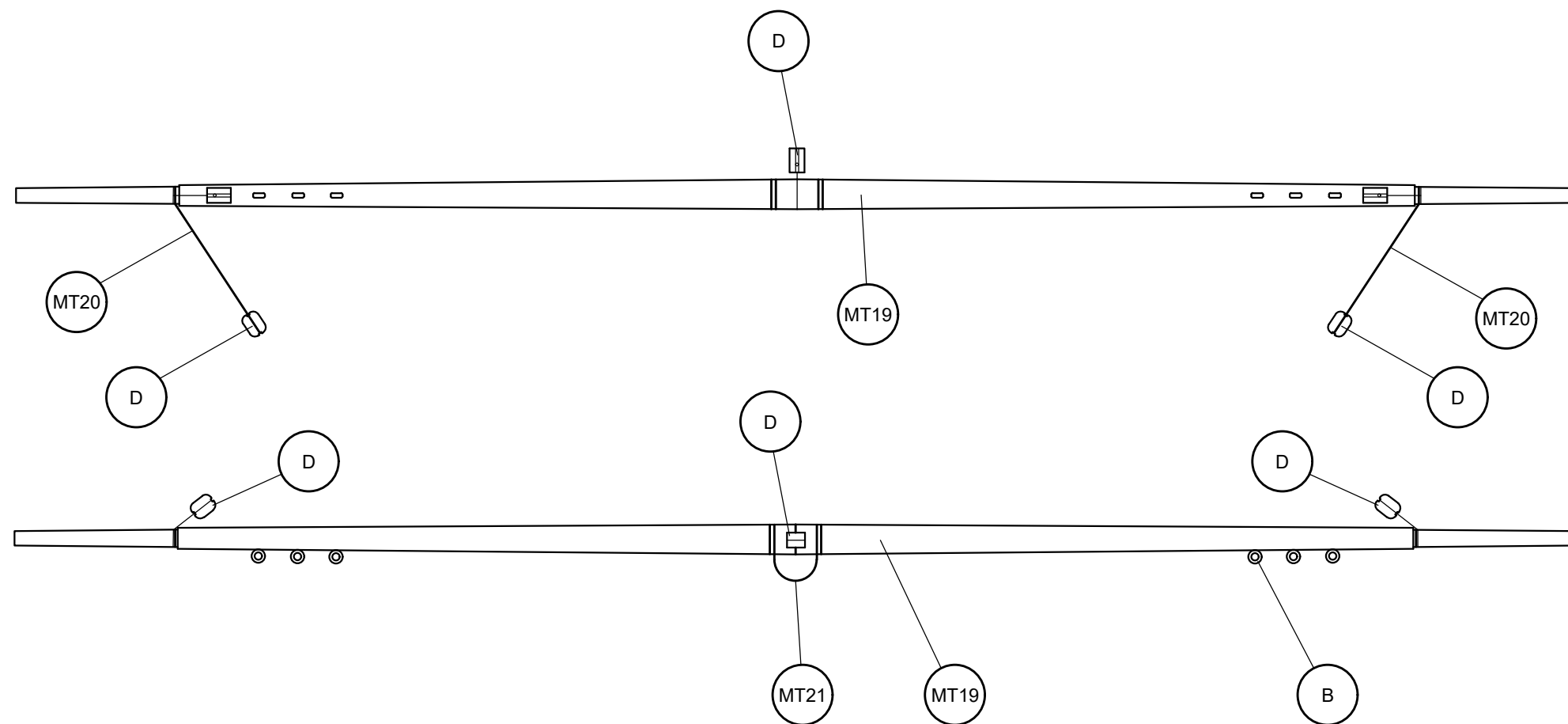
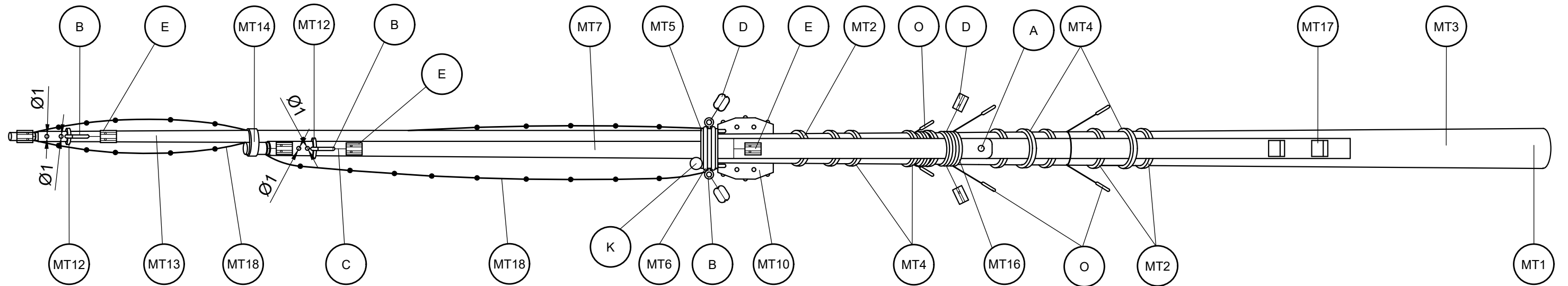

Scale 1/1

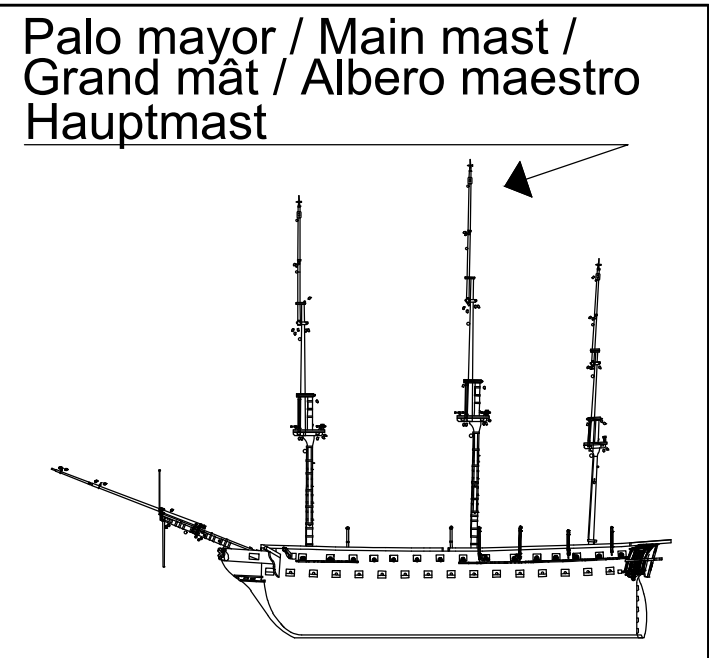
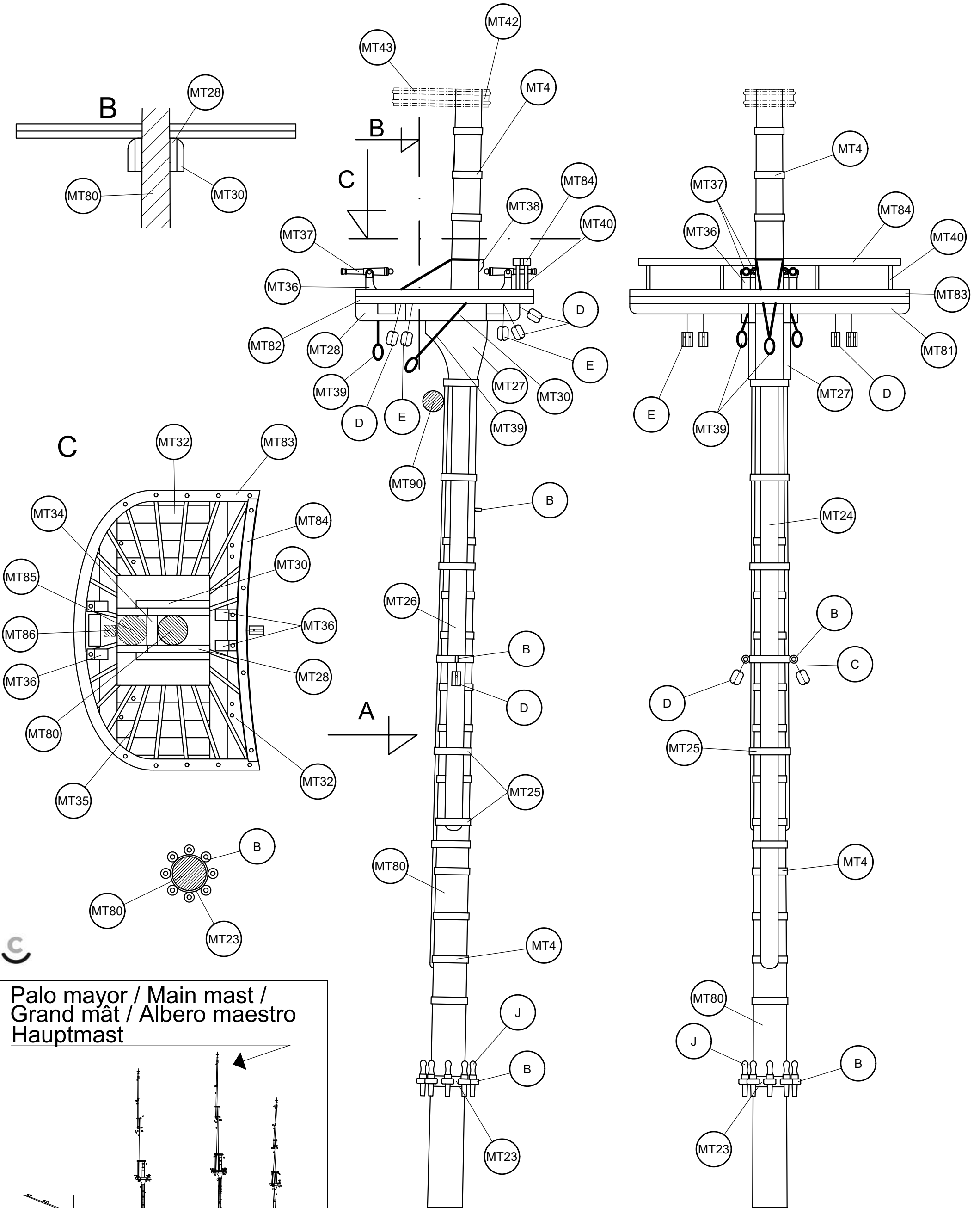

# La Belle Poule

Palo mayor / Main mast / Grand mât  
Albero maestro / Hauptmast

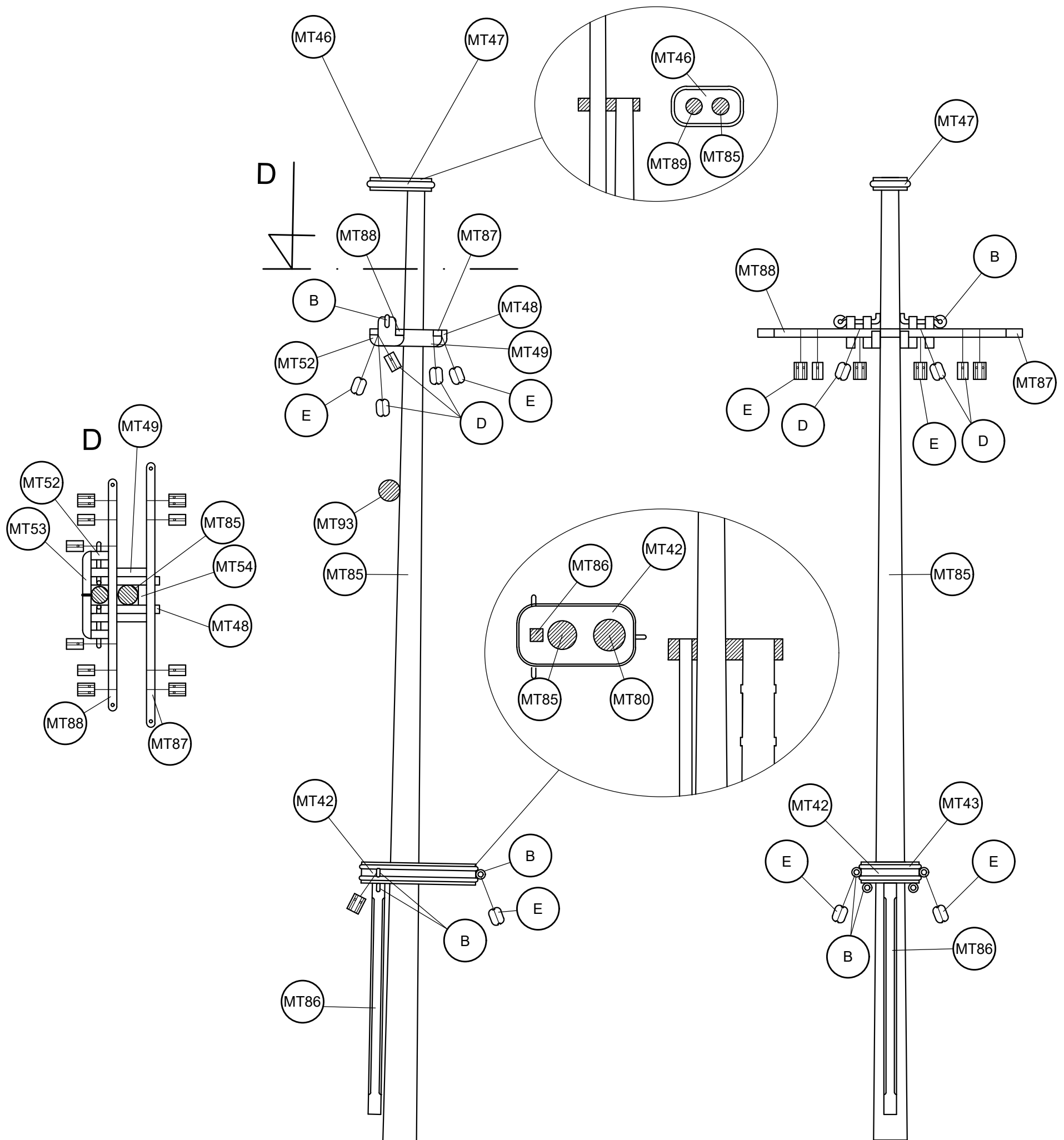

# La Belle Poule

Palo mayor / Main mast / Grand mât  
Albero maestro / Hauptmast

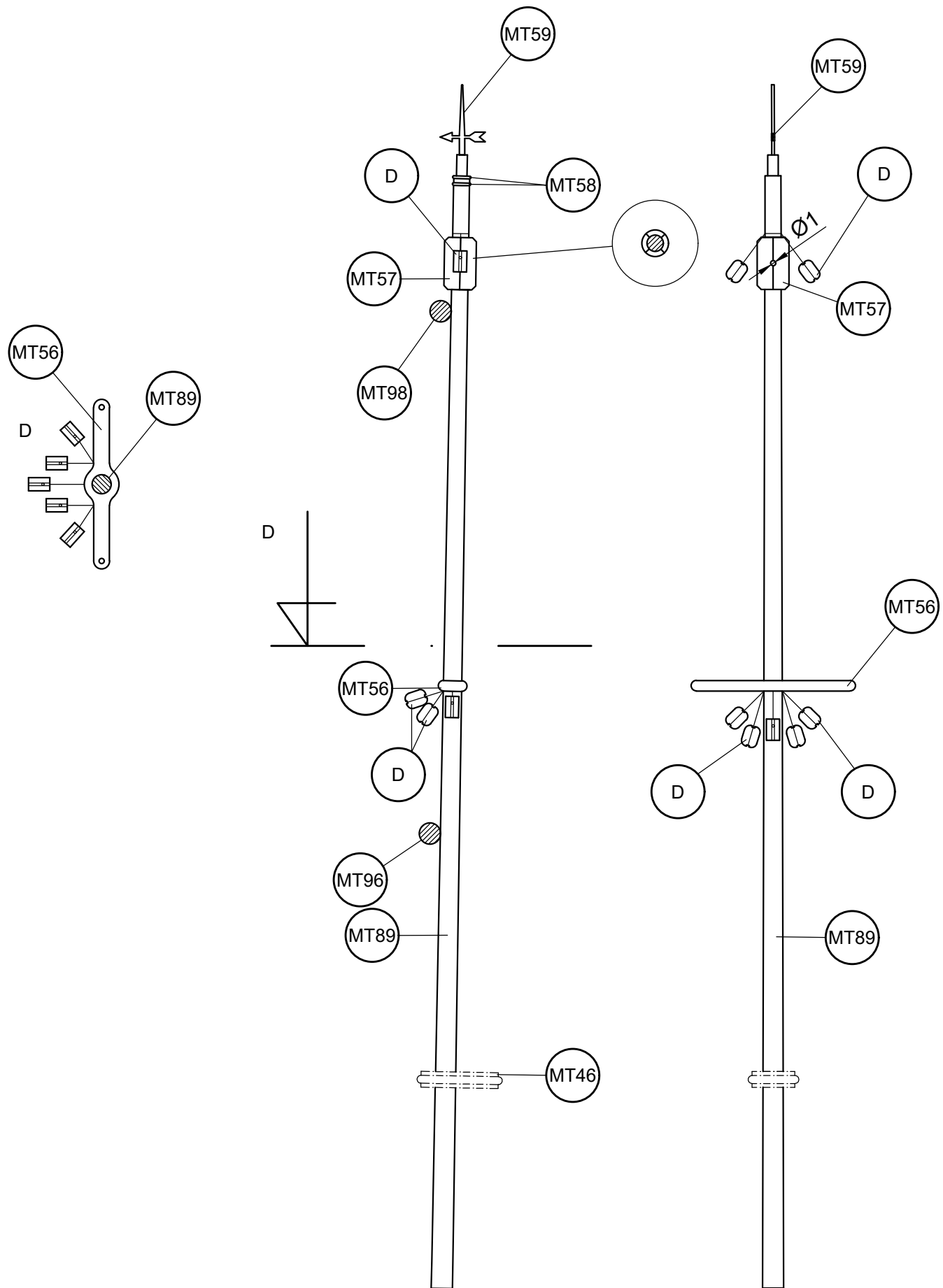

# La Belle Poule

Palo mayor / Main mast / Grand mât  
Albero maestro / Hauptmast

OCCRE

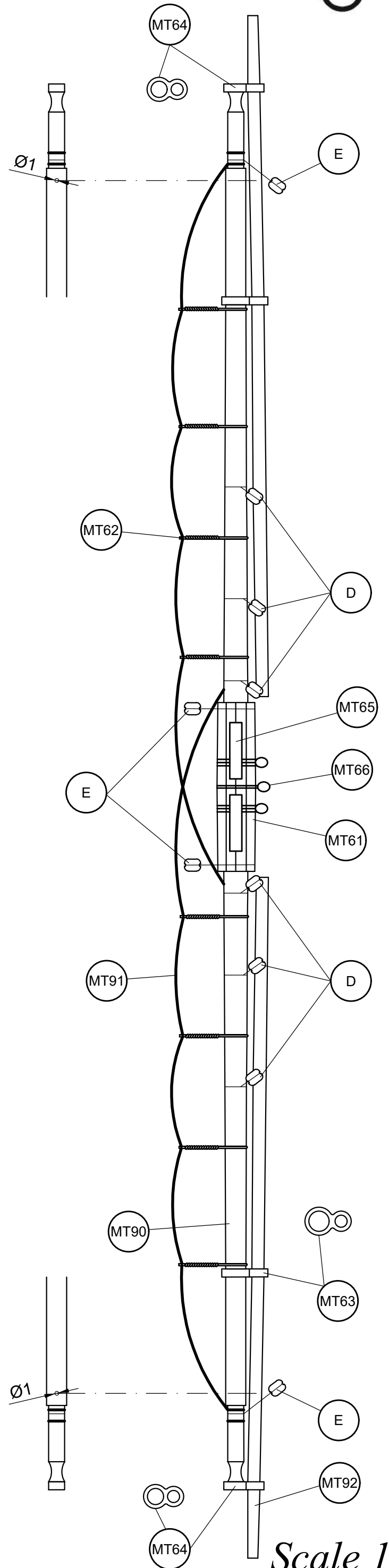
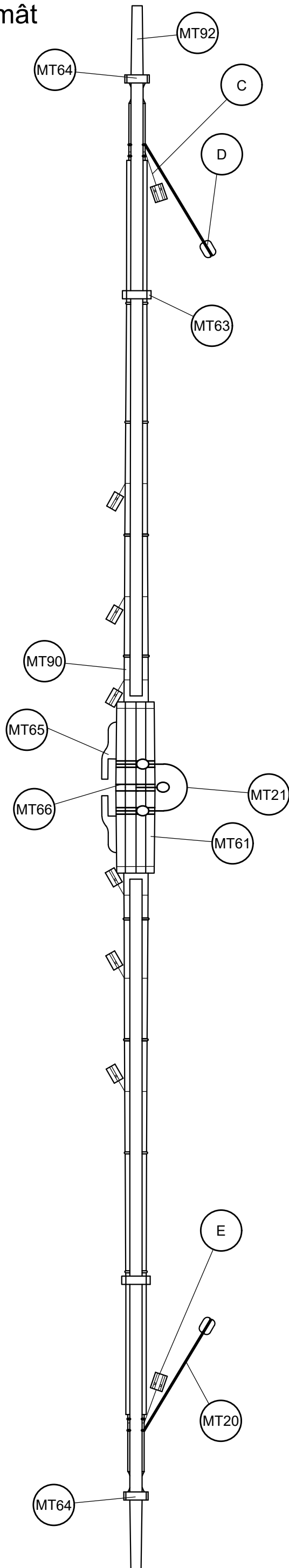
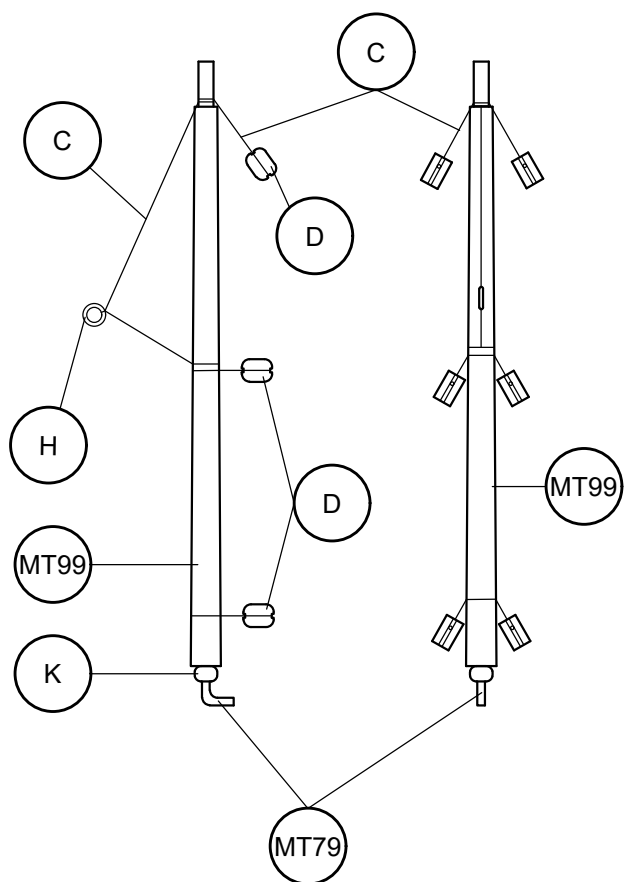
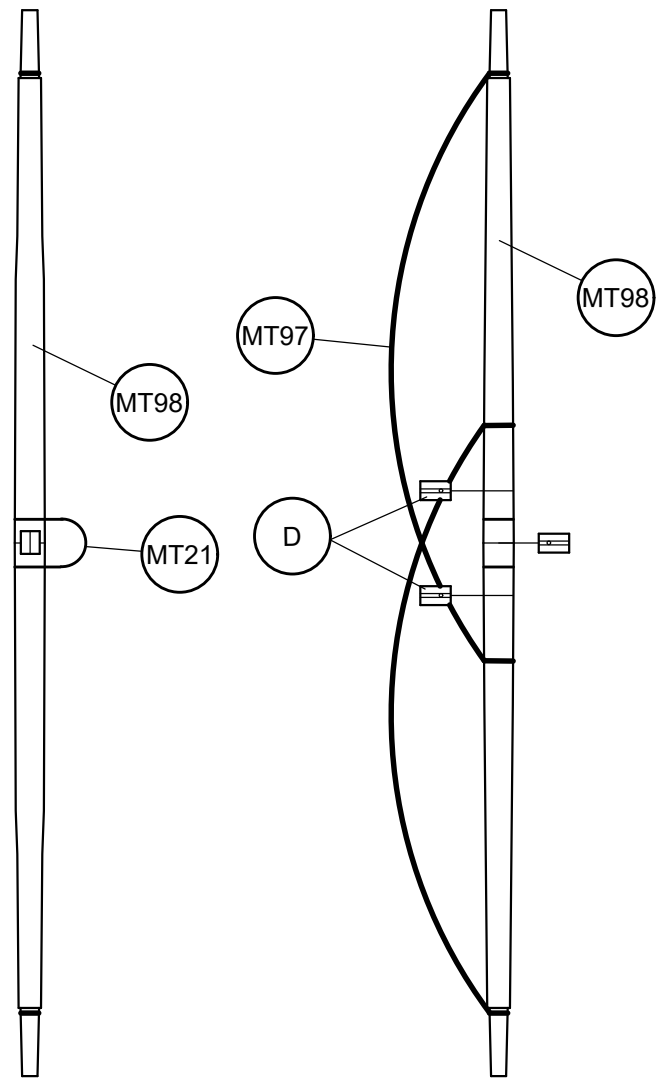

Scale 1/1

# La Belle Poule

Palo mayor / Main mast / Grand mât  
Albero maestro / Hauptmast

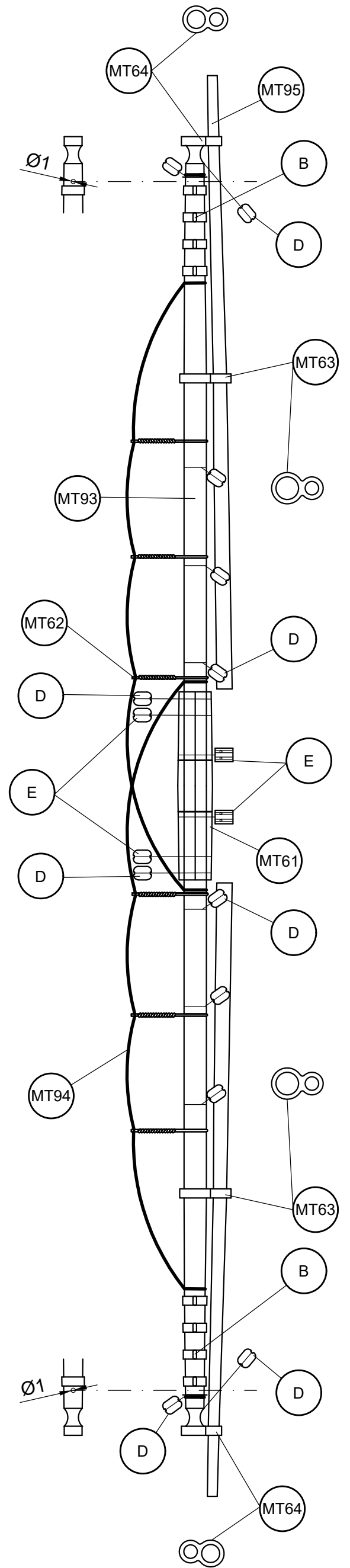
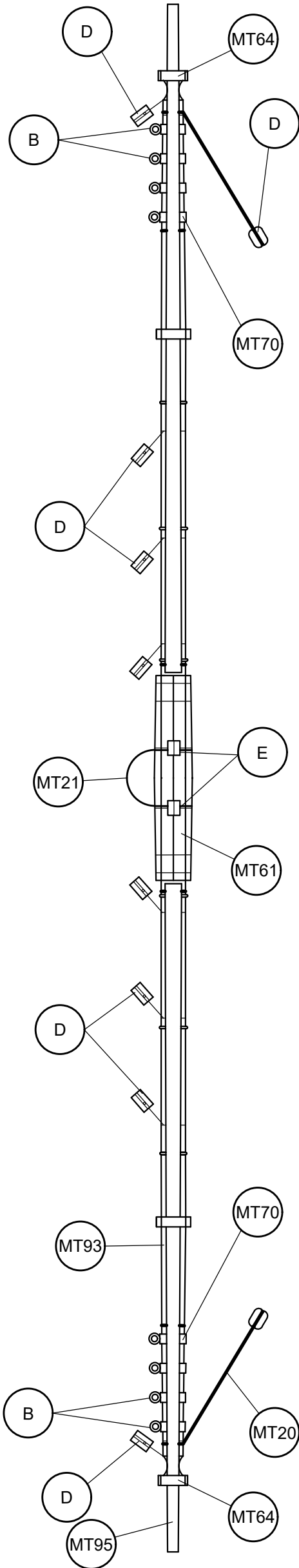
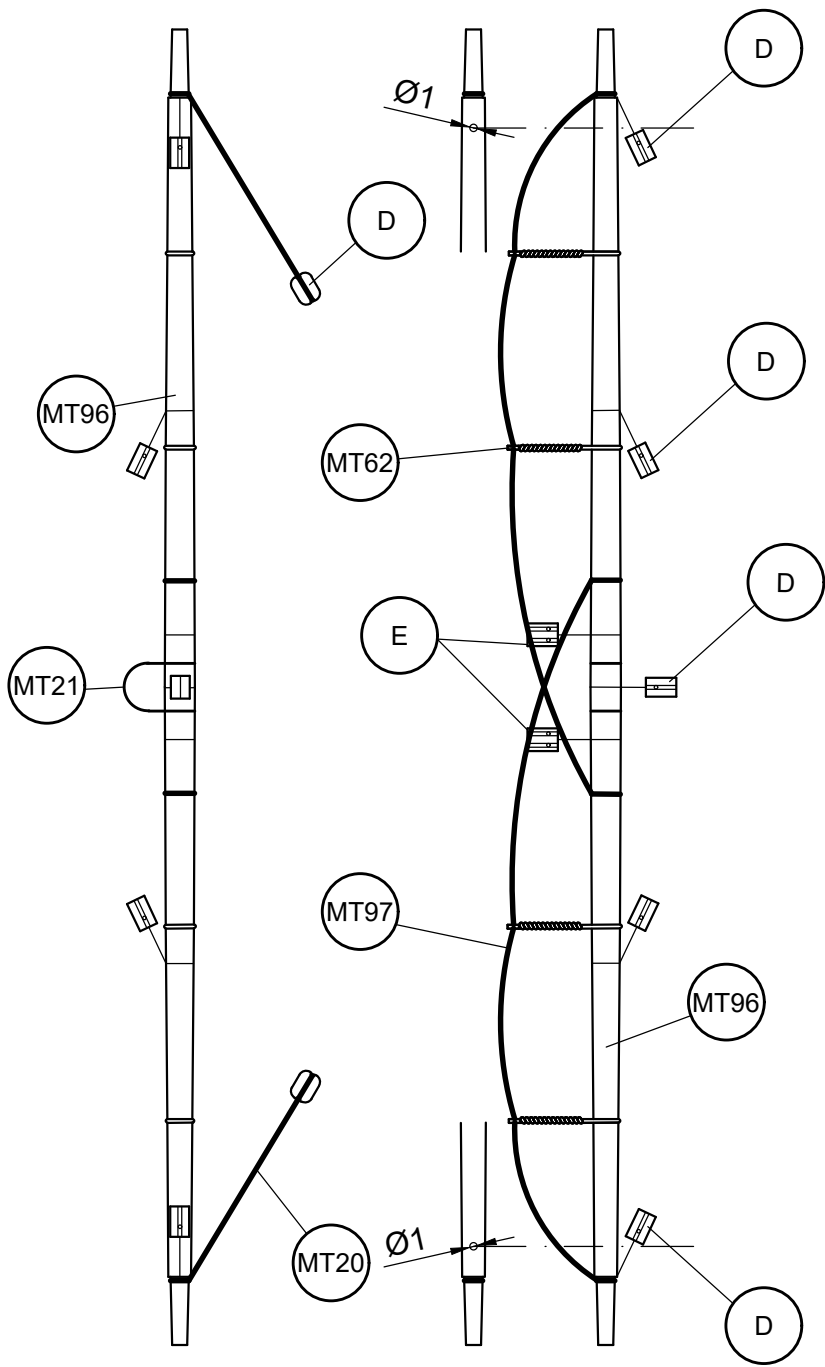

# La Belle Poule

OCCRE

Palo mesana/ Mizzen mast  
Mât d'artimon / Albero mezzana  
Besanmast

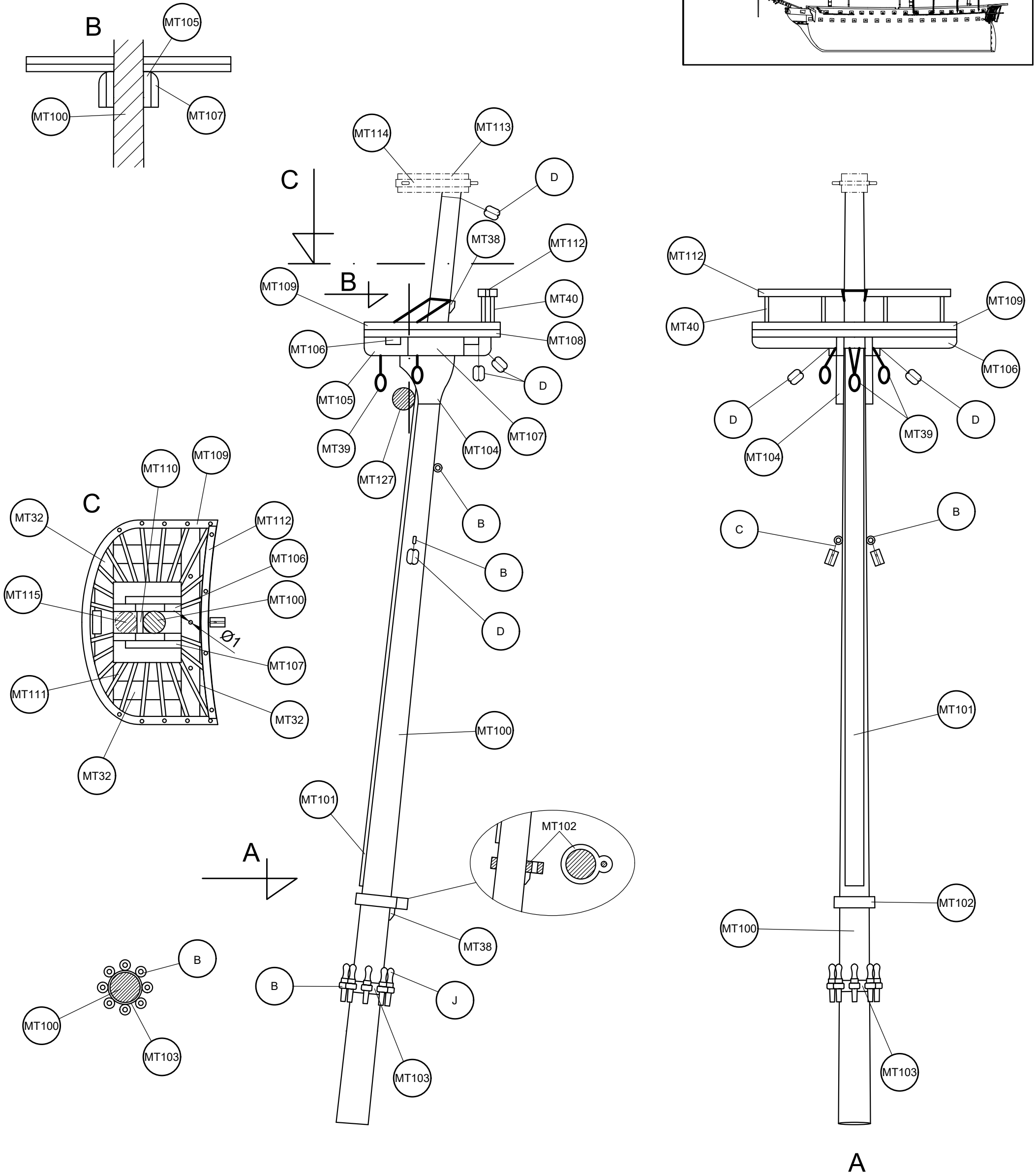
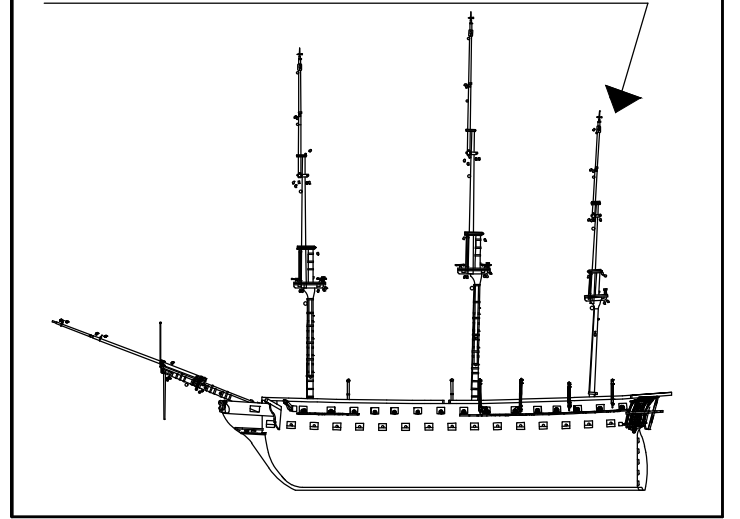

# La Belle Poule

Palo mesana/ Mizzen mast / Mât d'artimon  
Albero mezzana / Besanmast

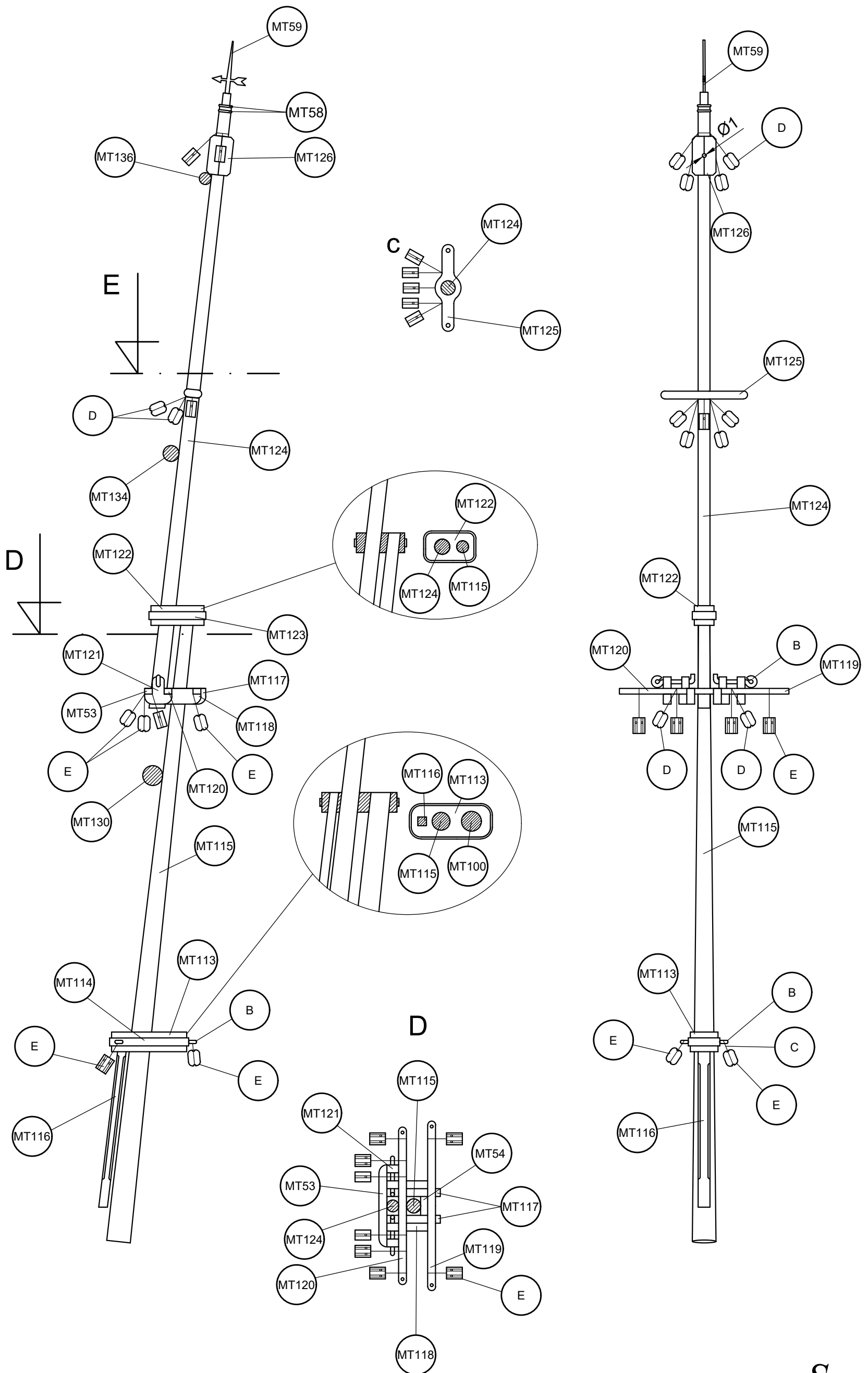

# La Belle Poule

Palo mesana/ Mizzen mast / Mât d'artimon  
Albero mezzana / Besanmast

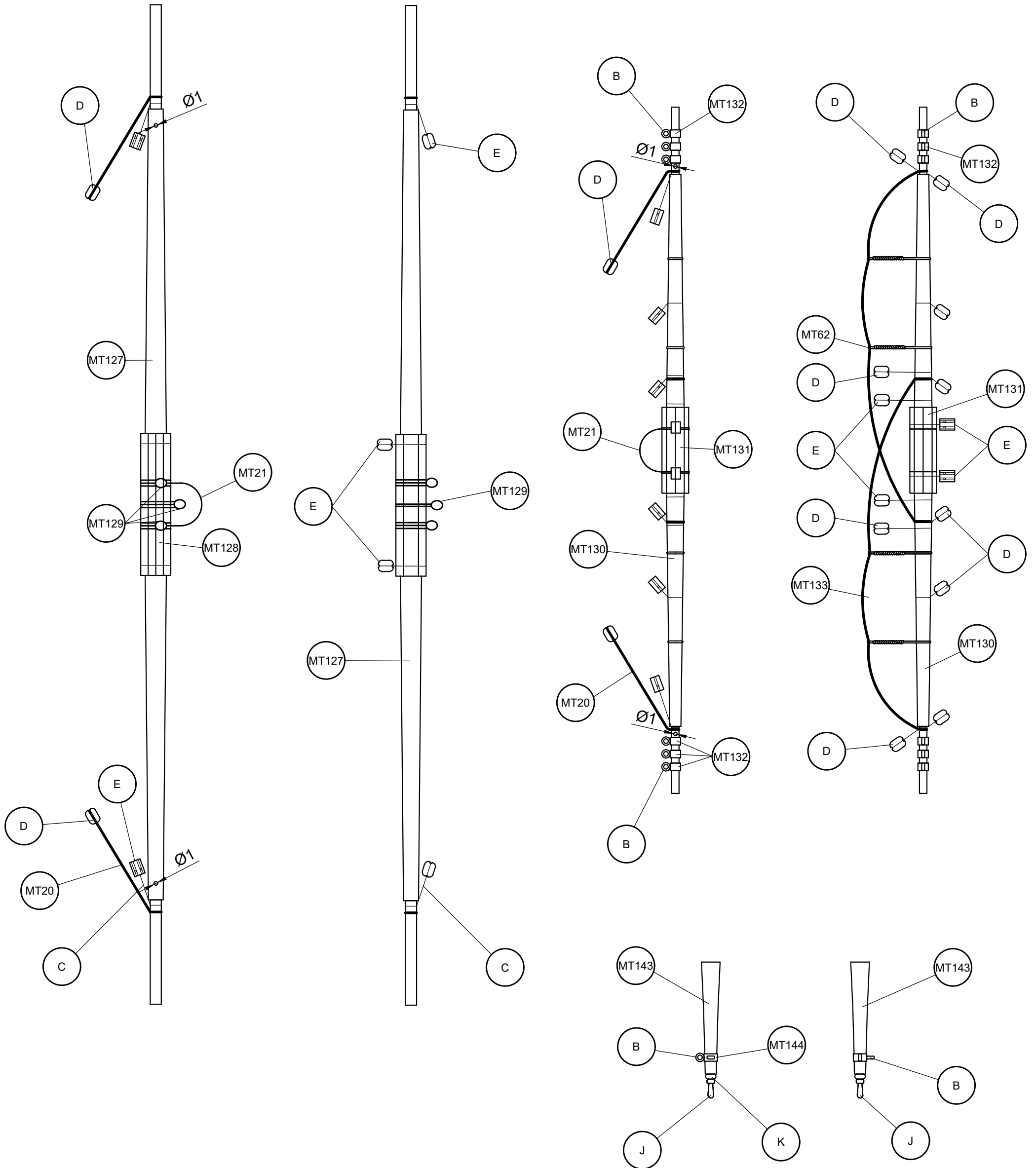

Scale 1/1

# La Belle Poule

Palo mesana/ Mizzen mast / Mât d'artimon  
Albero mezzana / Besanmast

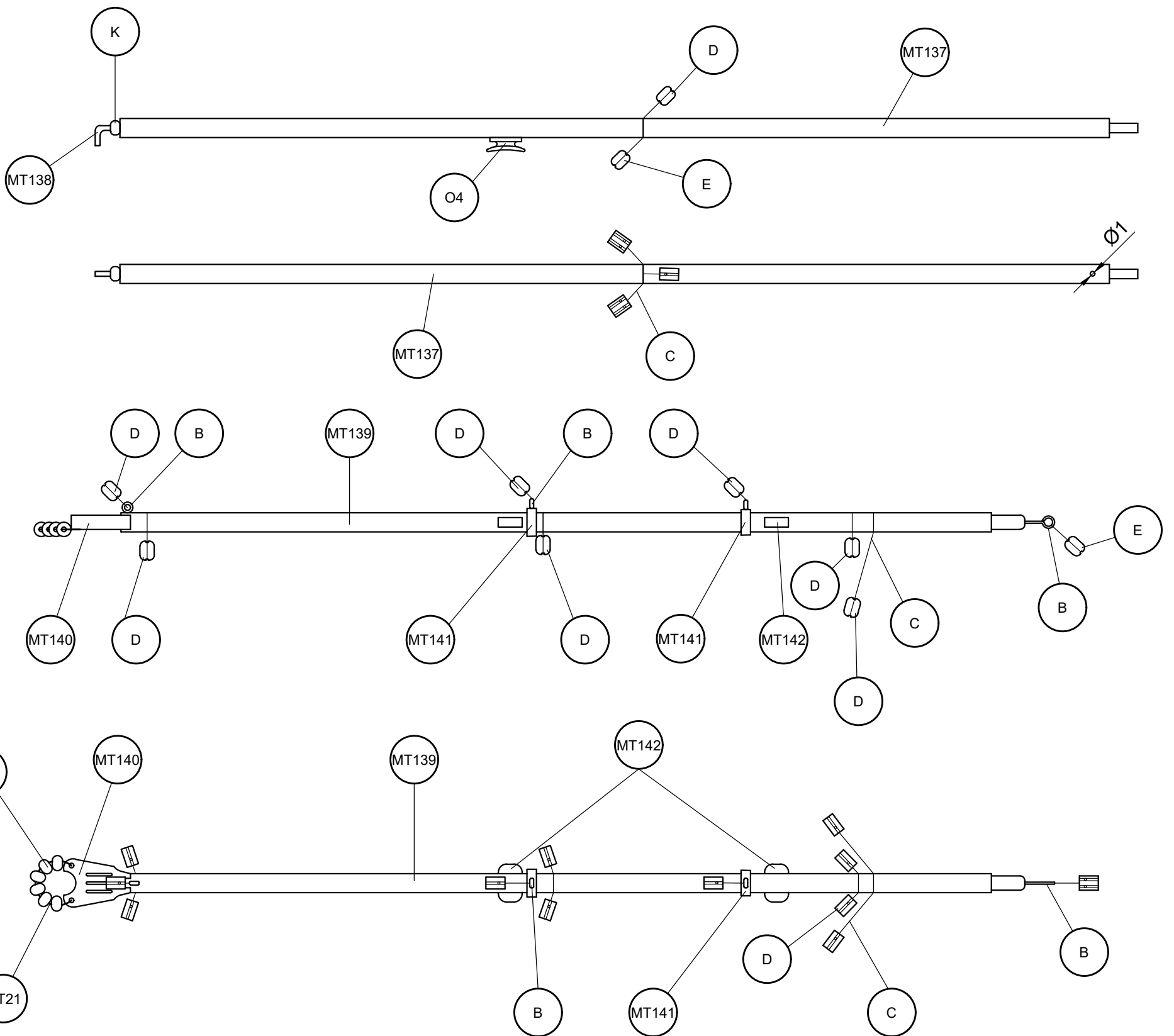
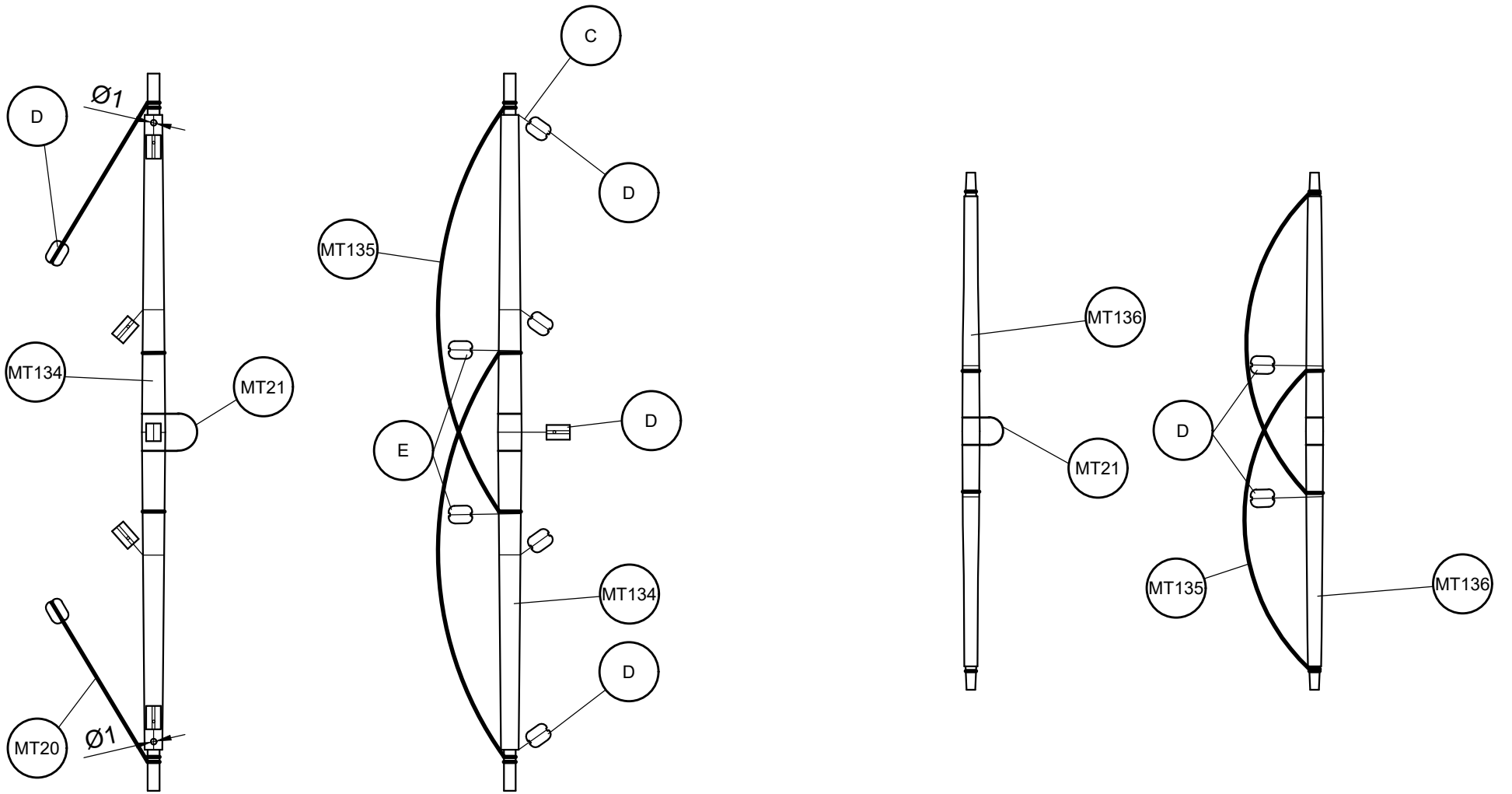

# La Belle Poule

OCCRE

Palo trinquete / Fore mast  
Mât de misaine / Albero trinchetto  
Fockmast

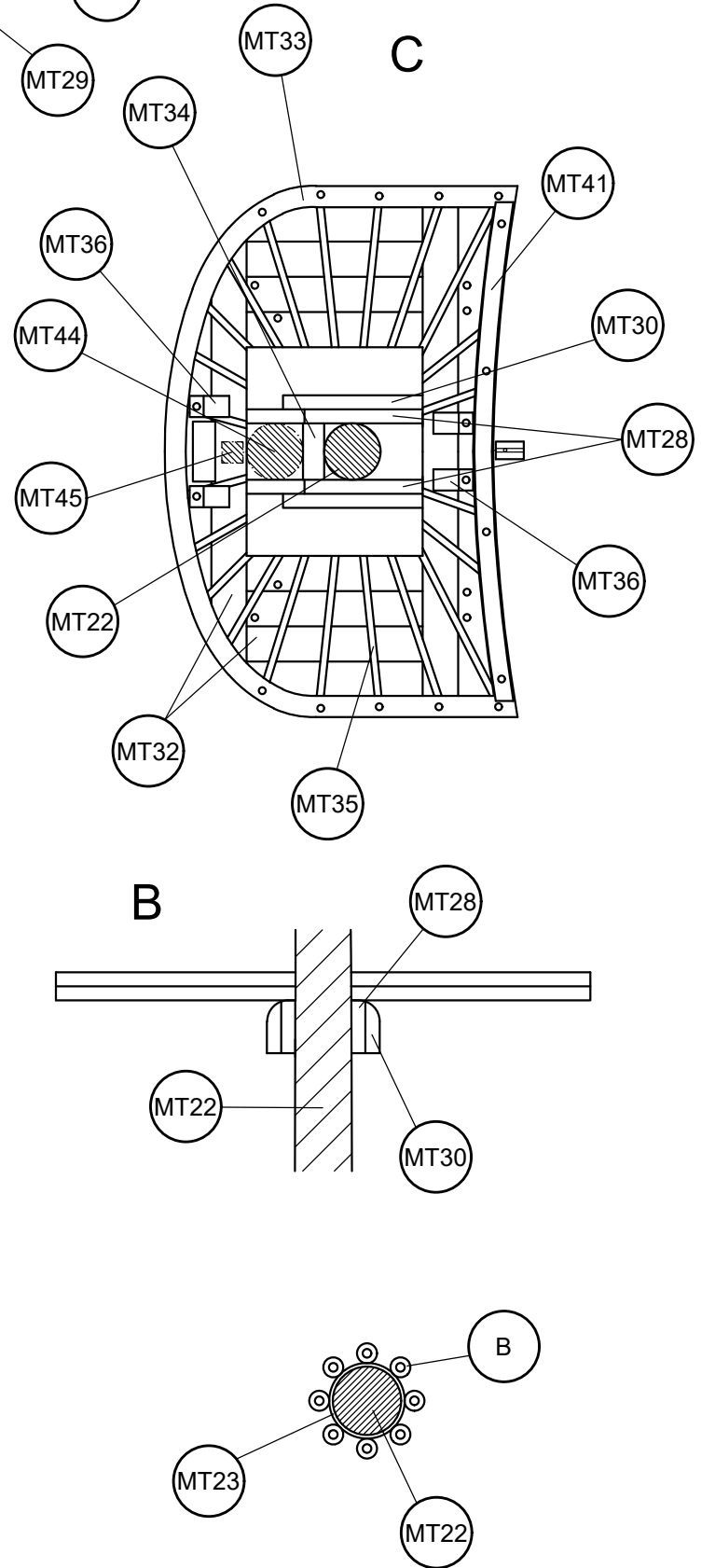
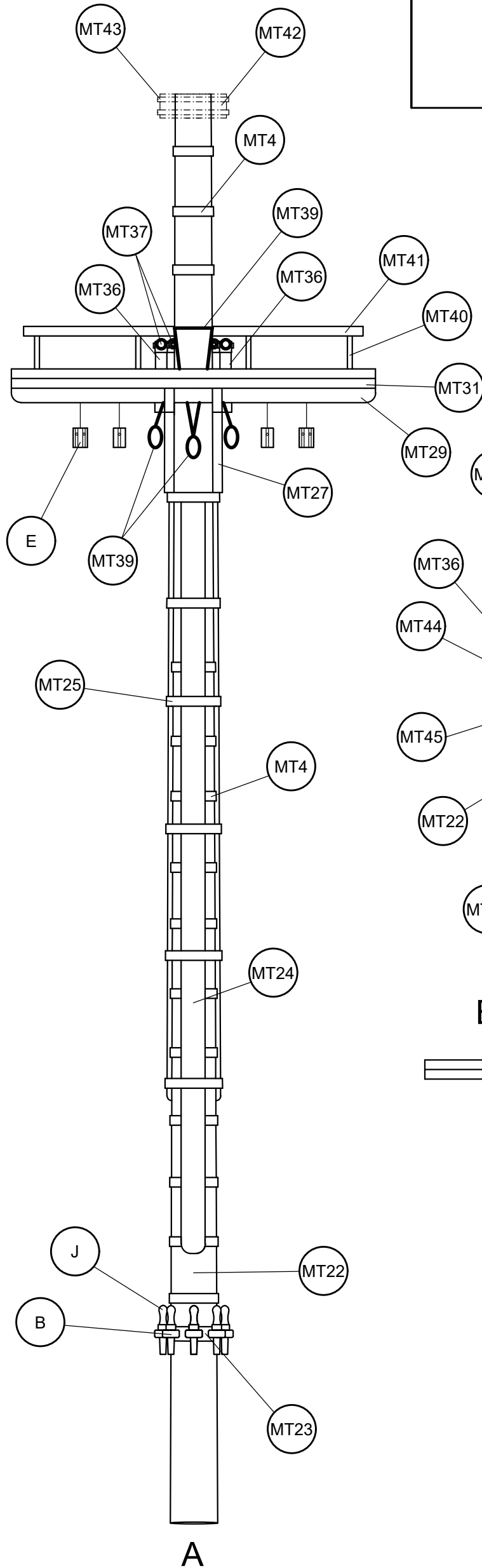
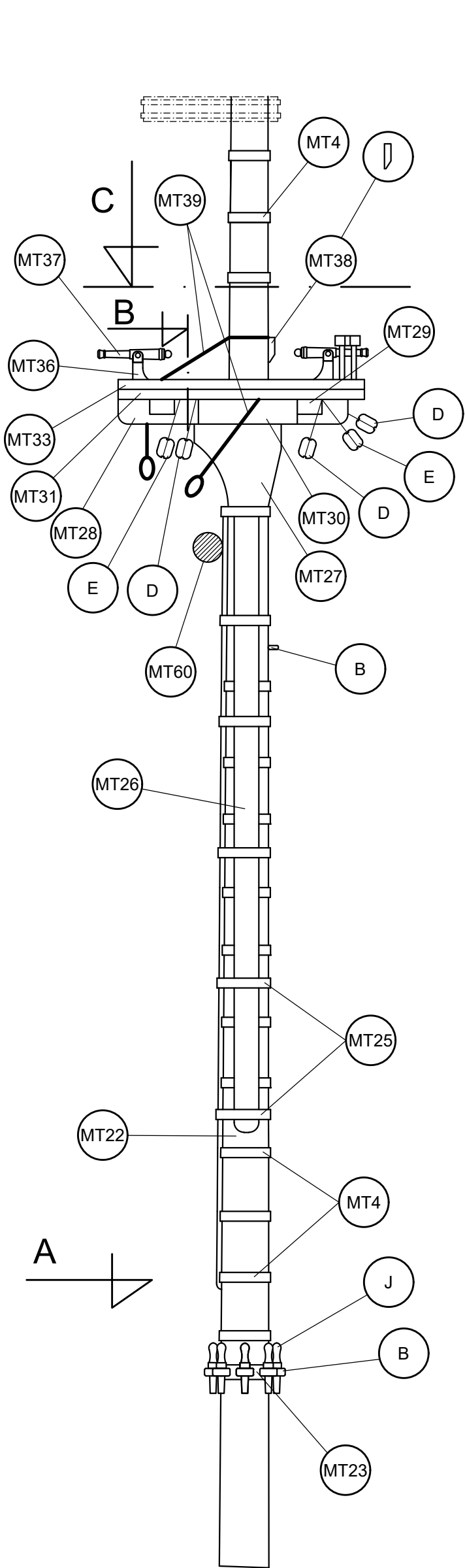
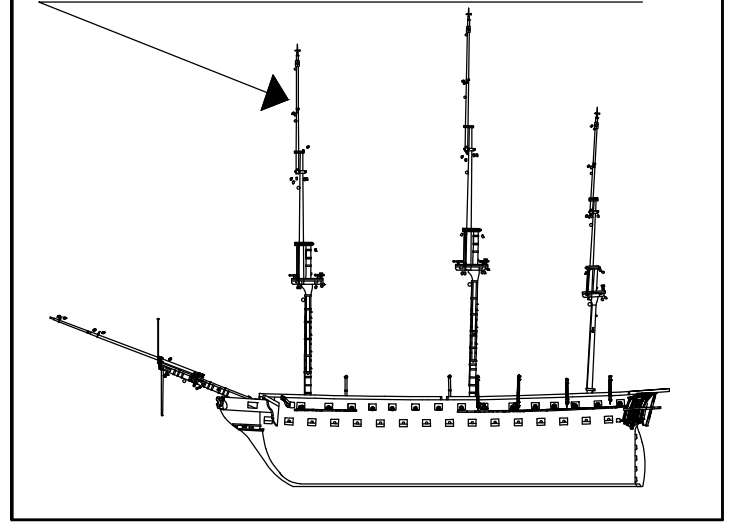

# La Belle Poule

Palo trinquete  
Fore mast  
Mât de misaine  
Albero trinchetto  
Fockmast

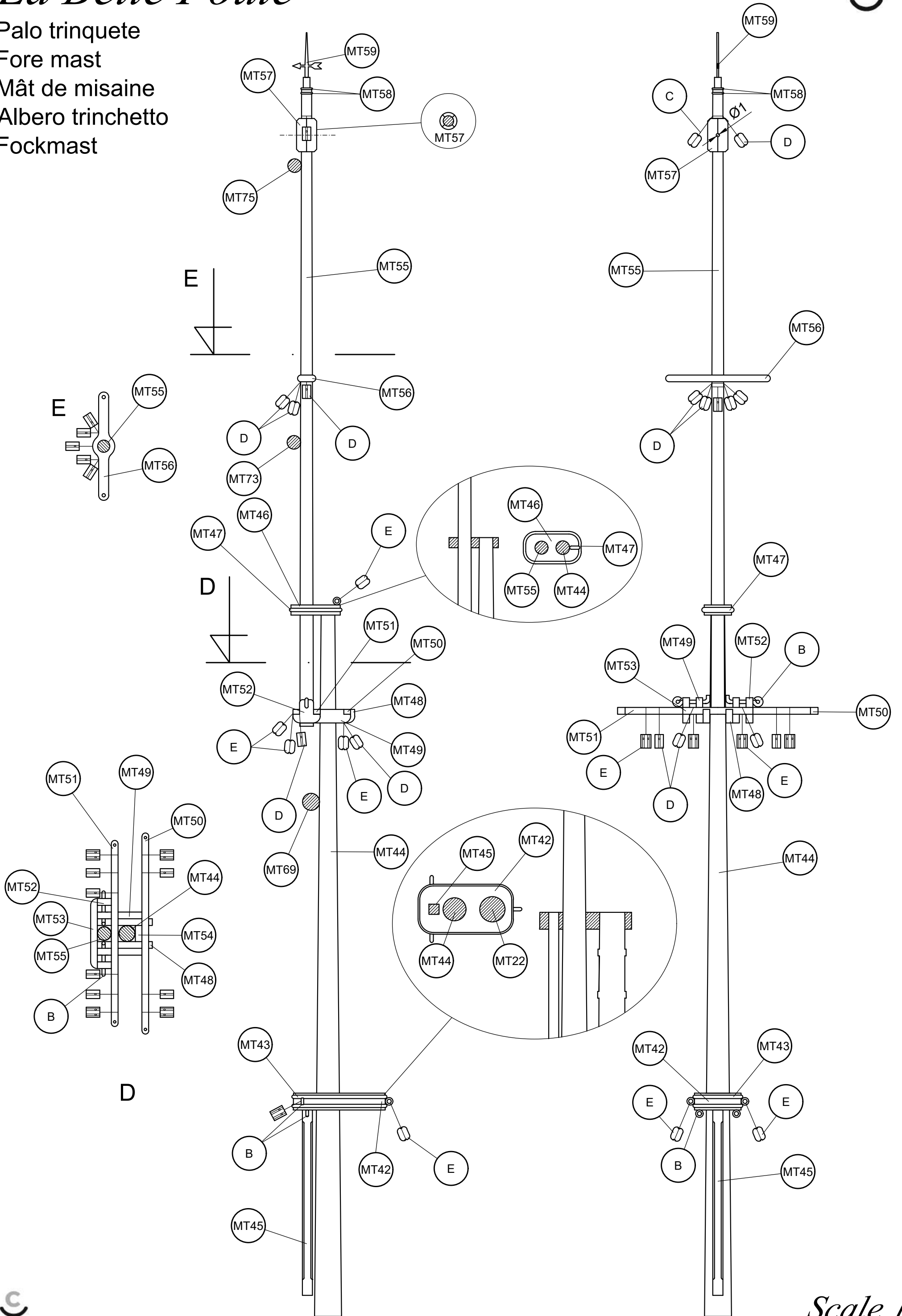

# La Belle Poule

Palo trinquete / Fore mast / Mât de misaine  
Albero trinchetto / Fockmast

OCCRE

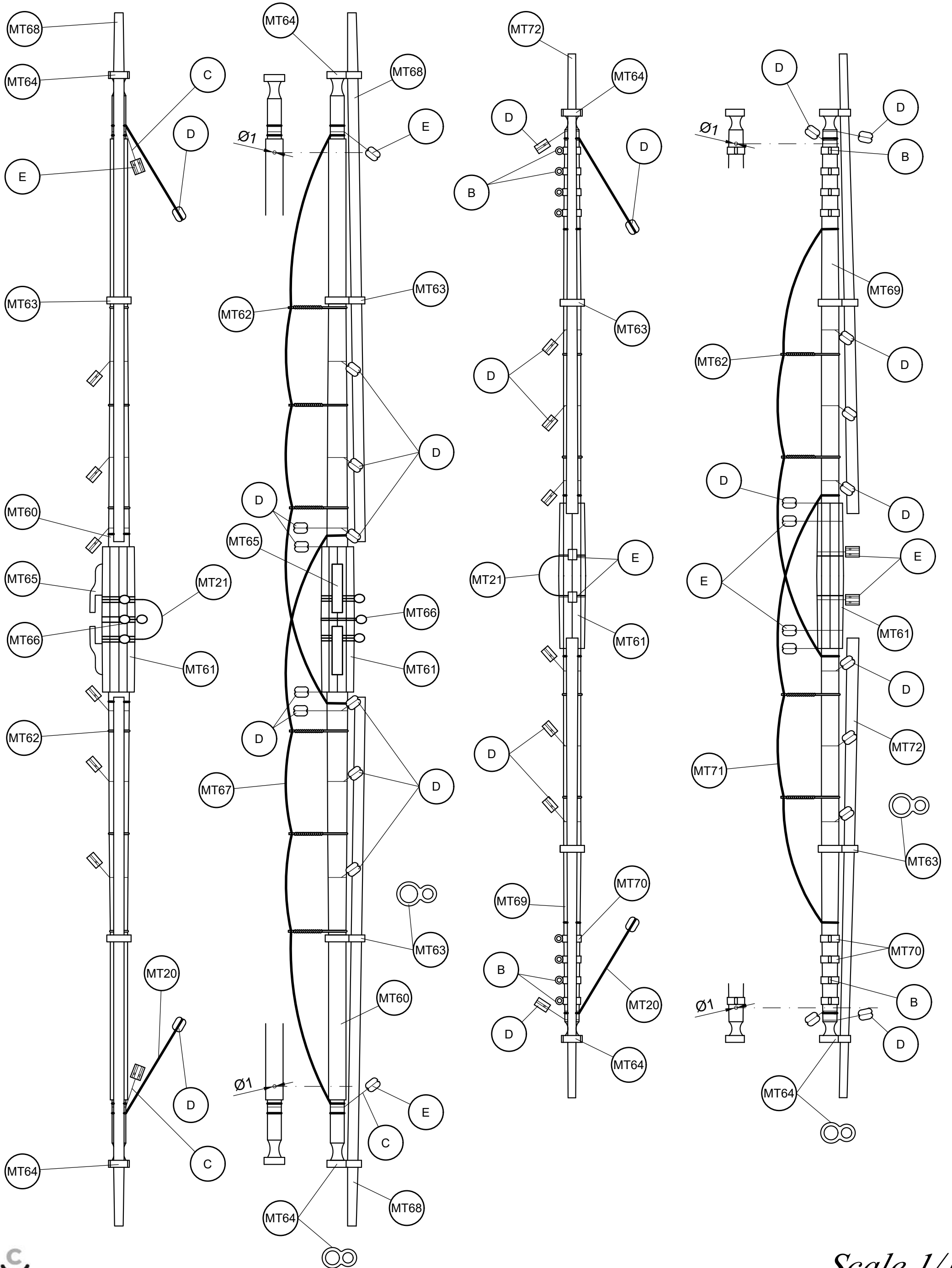

Scale 1/1

# La Belle Poule

Palo trinquete / Fore mast / Mât de misaine  
Albero trinchetto / Fockmast

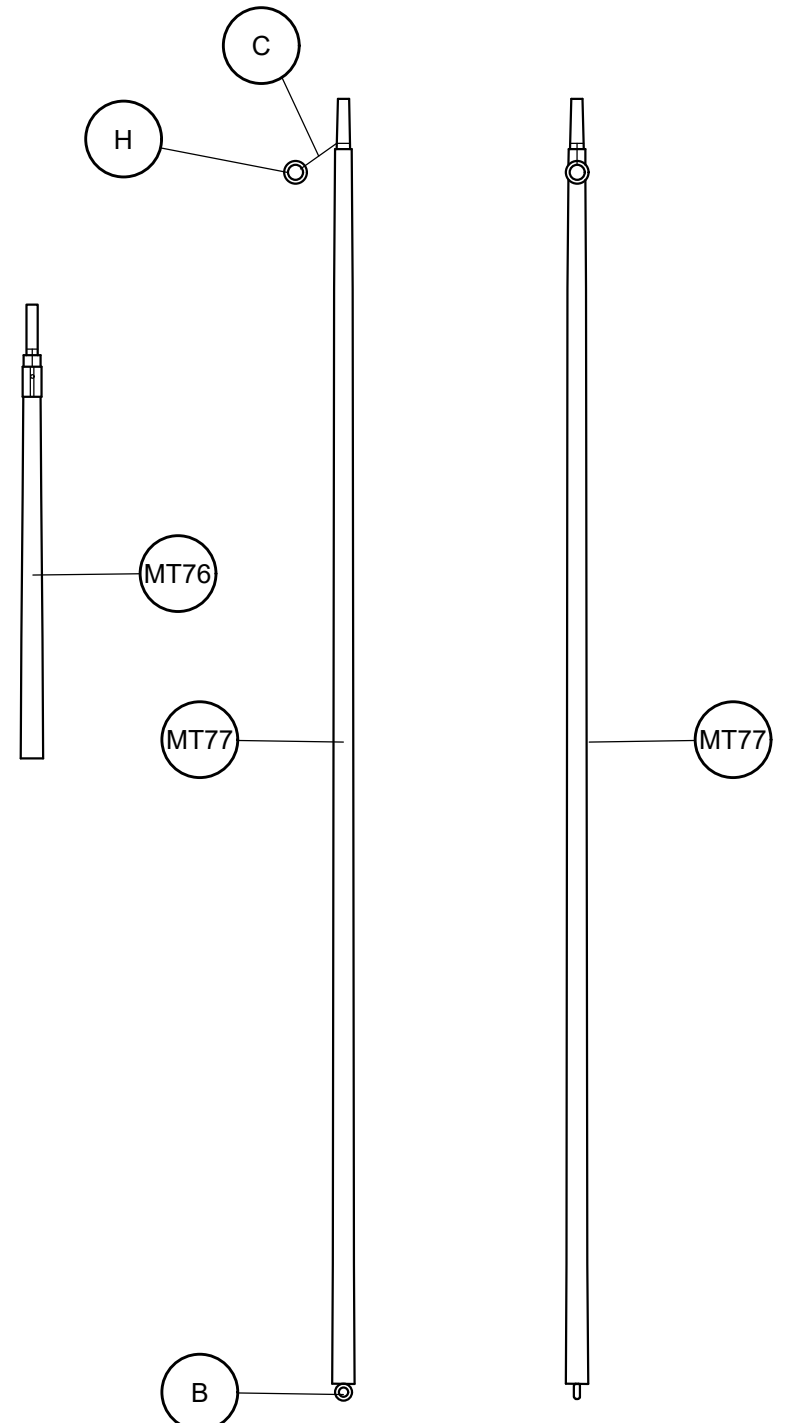
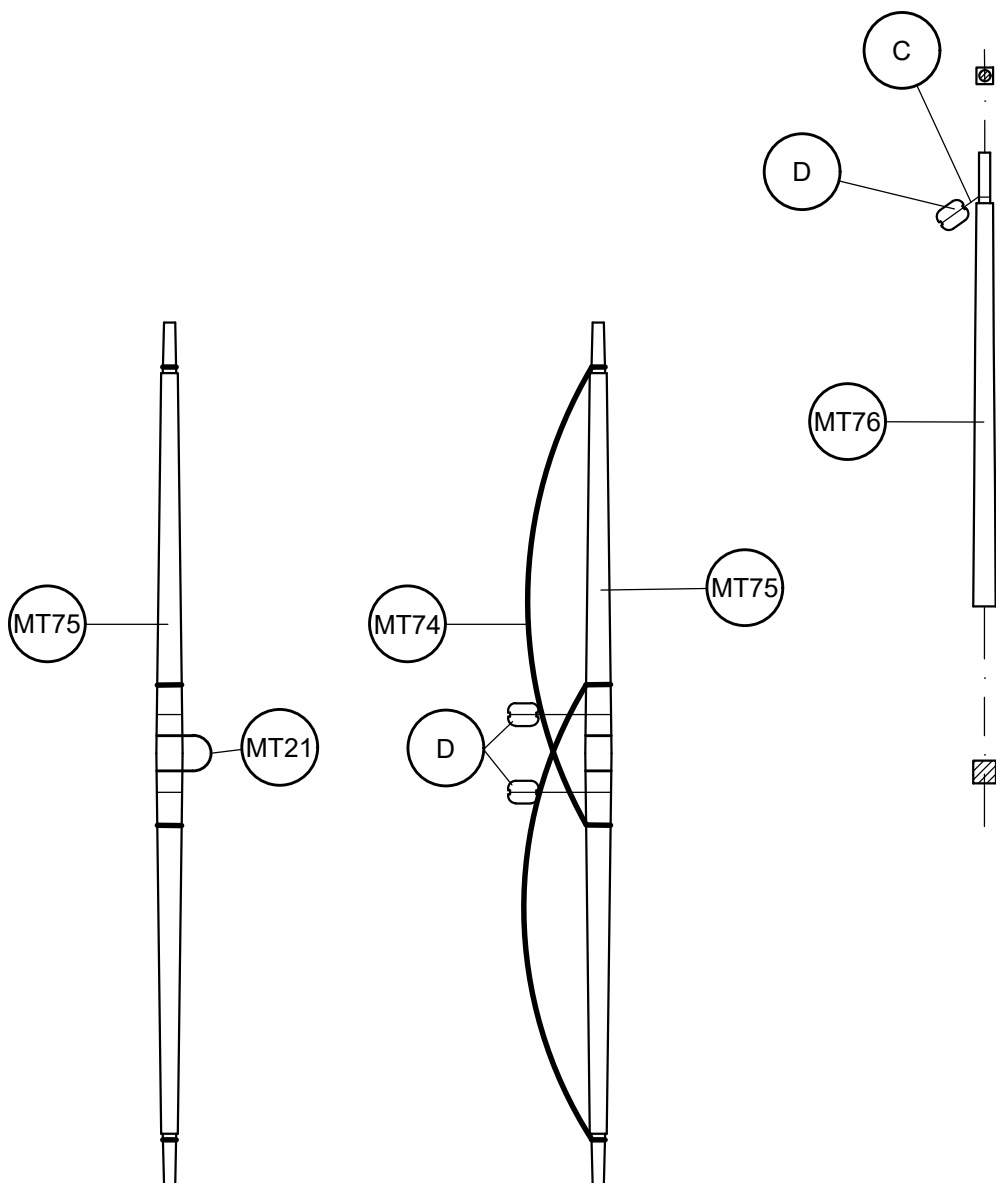
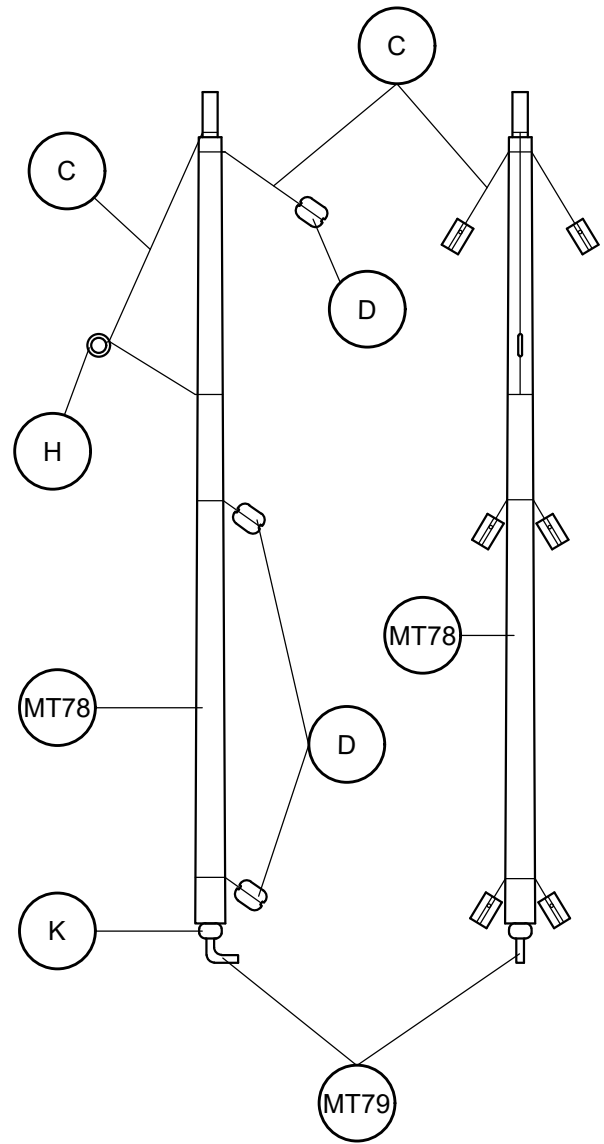
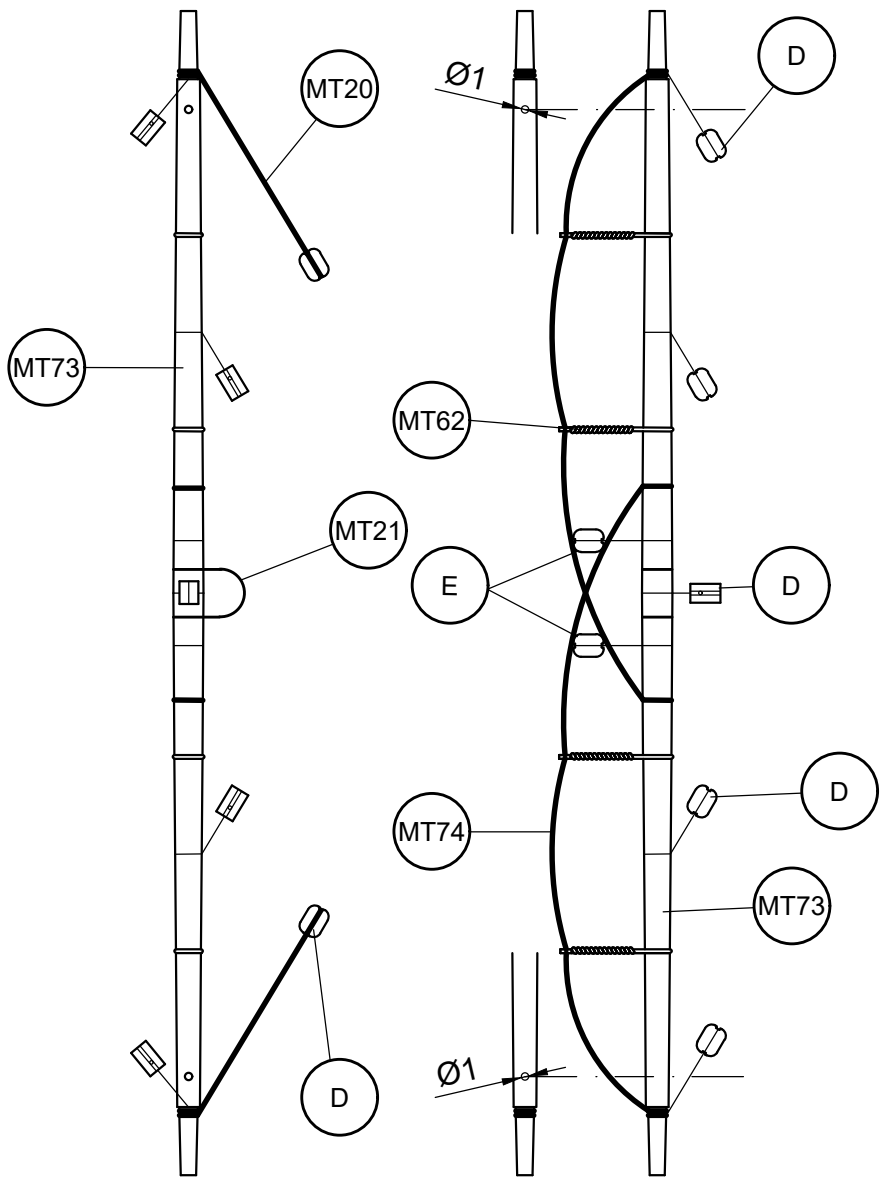

# La Belle Poule

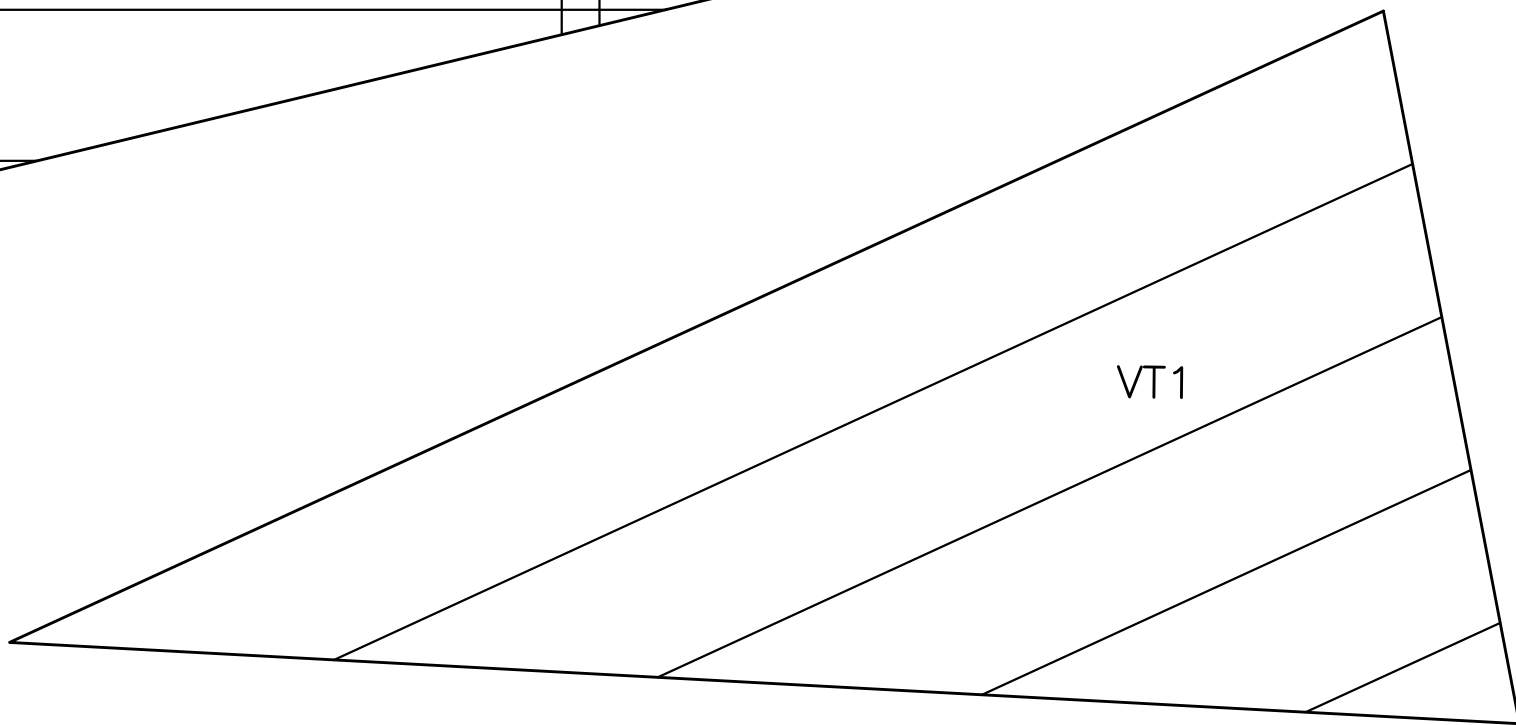
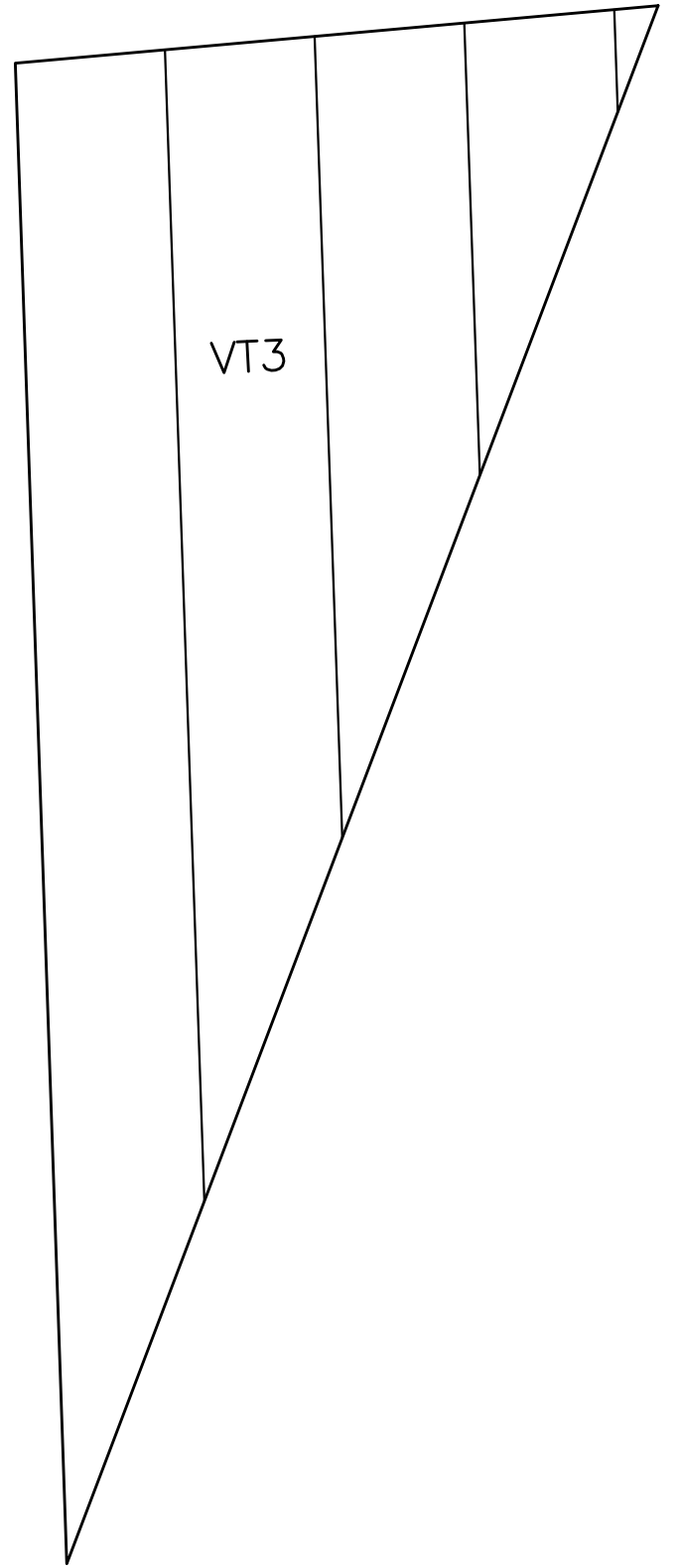
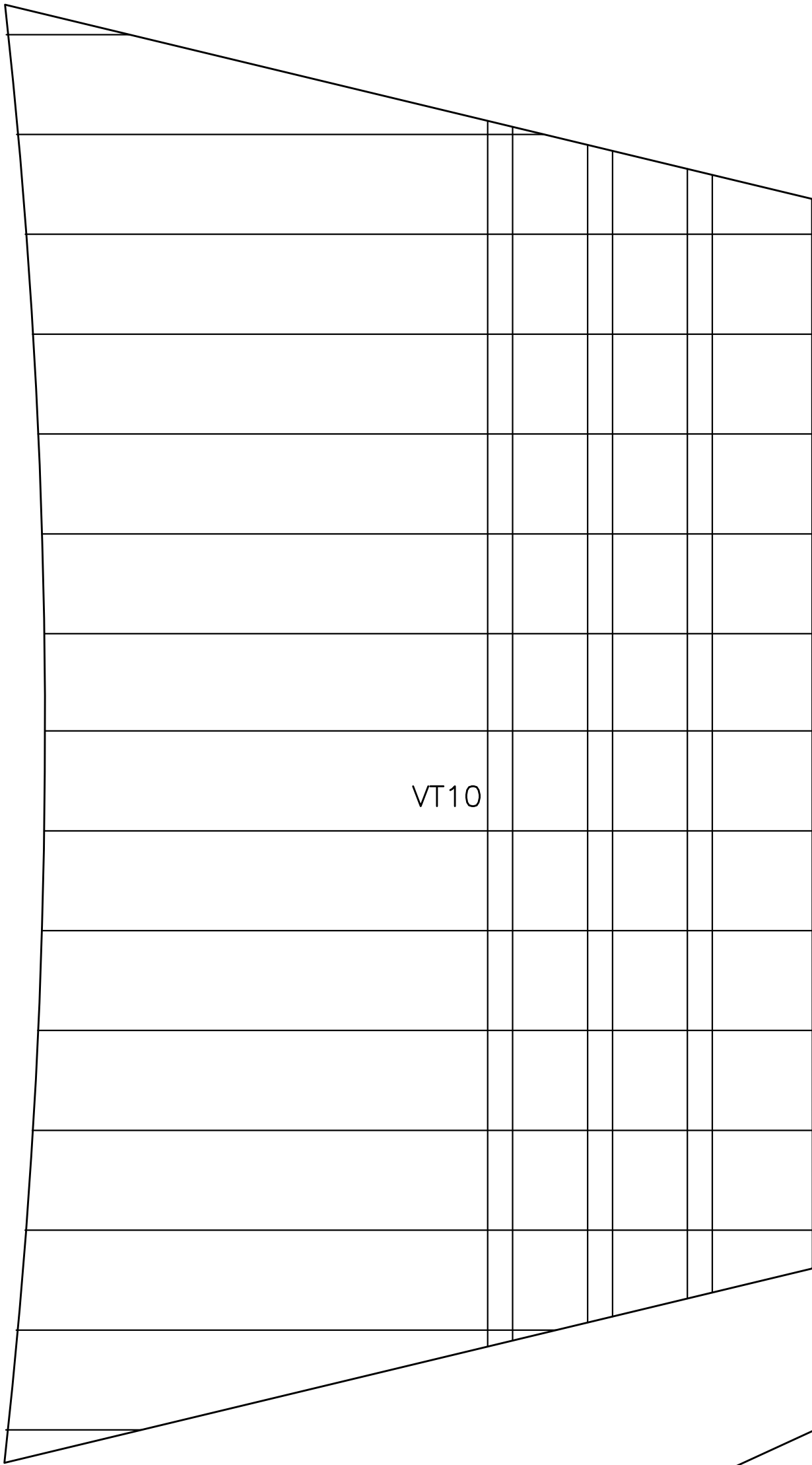

# La Belle Poule

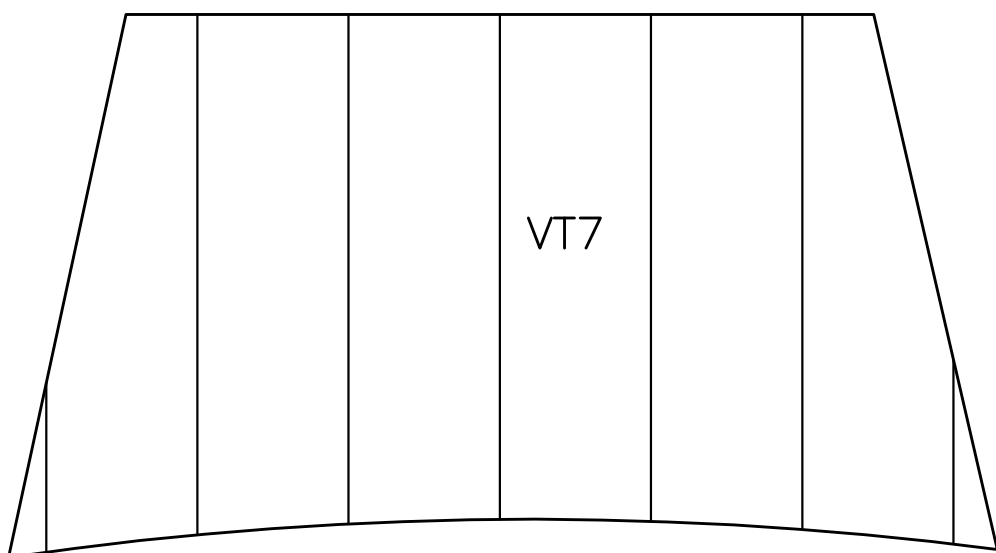
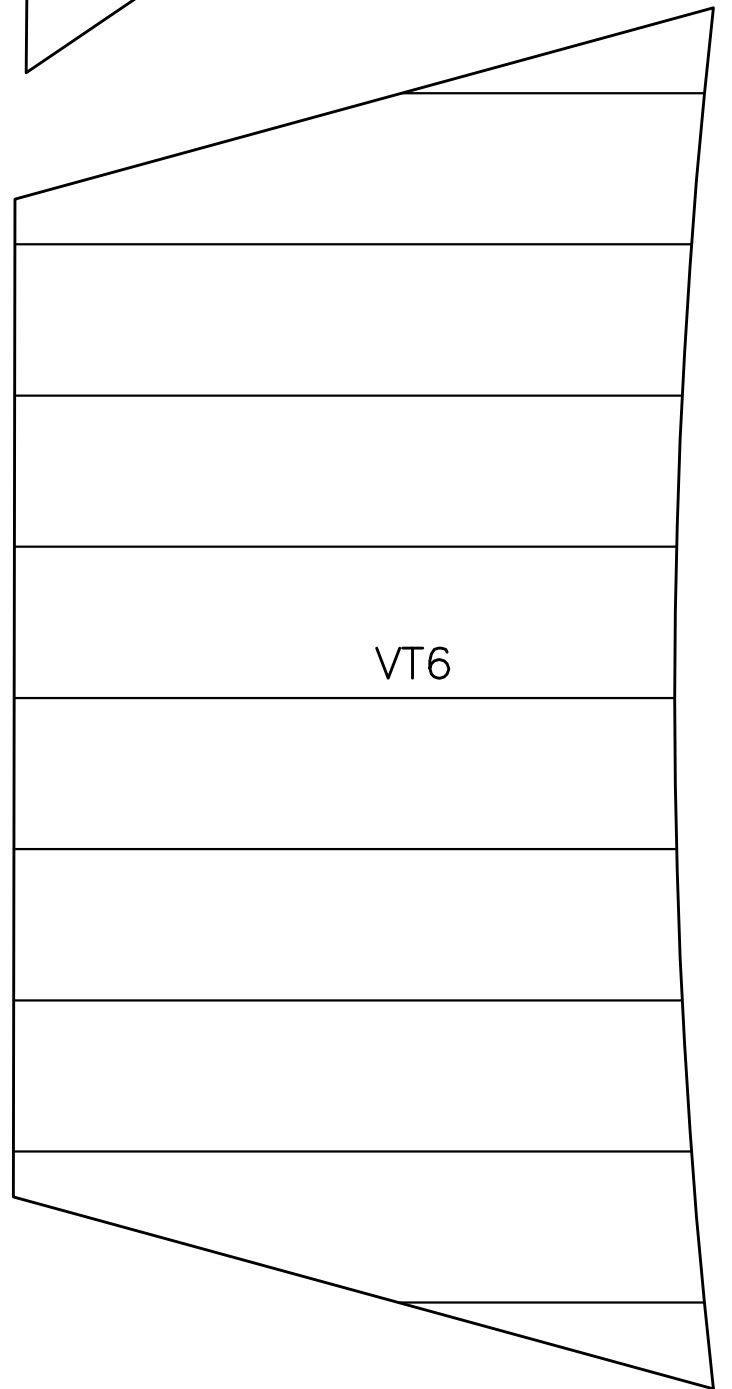
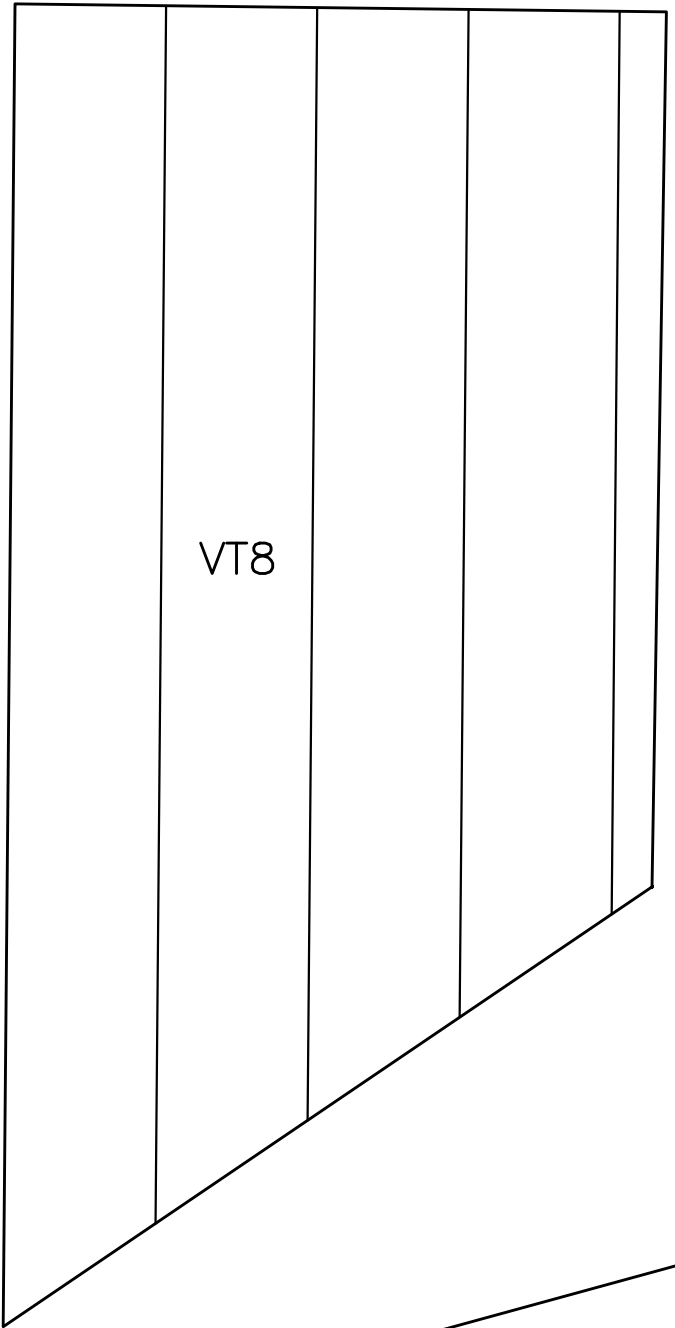
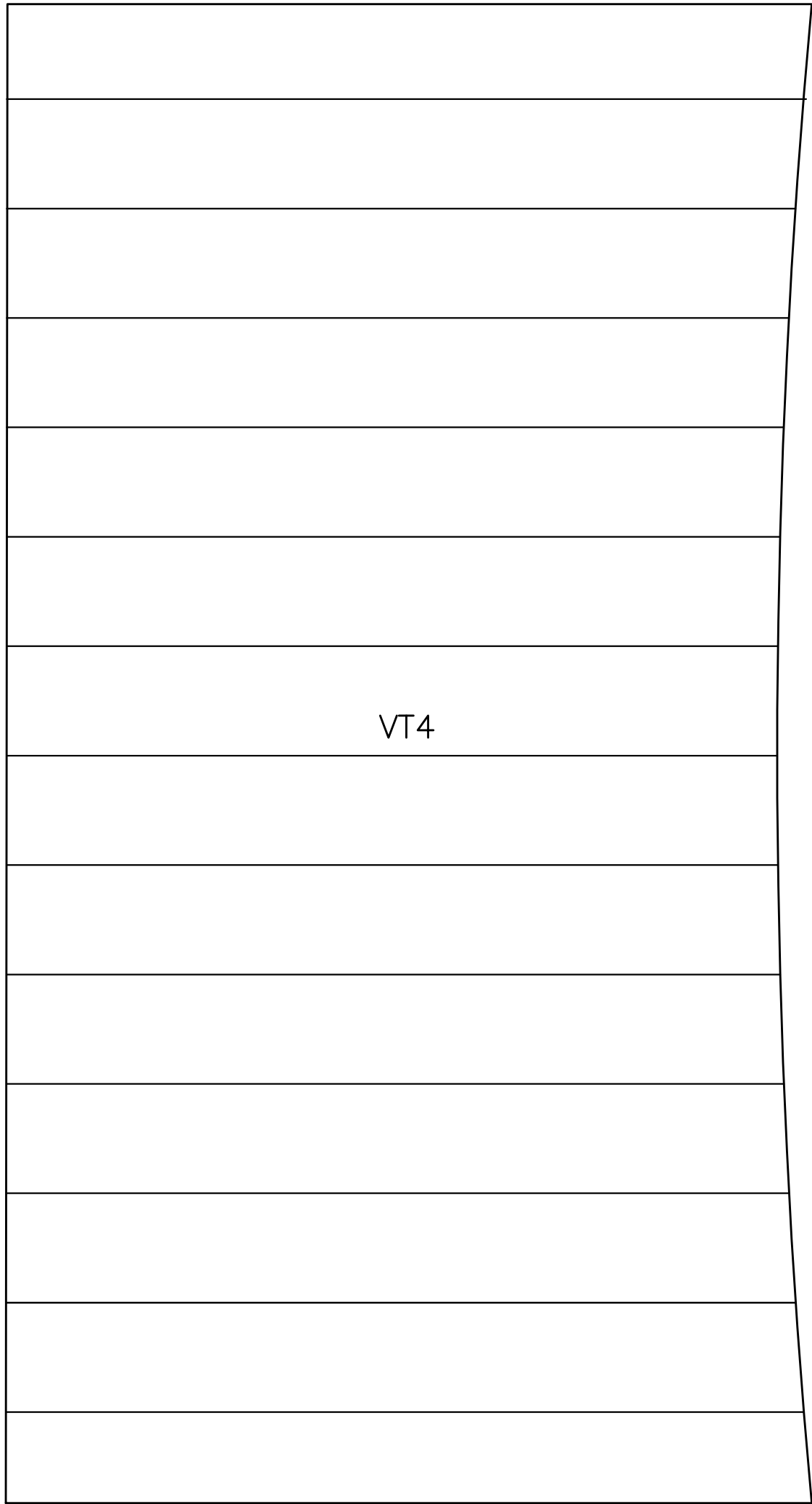

# La Belle Poule

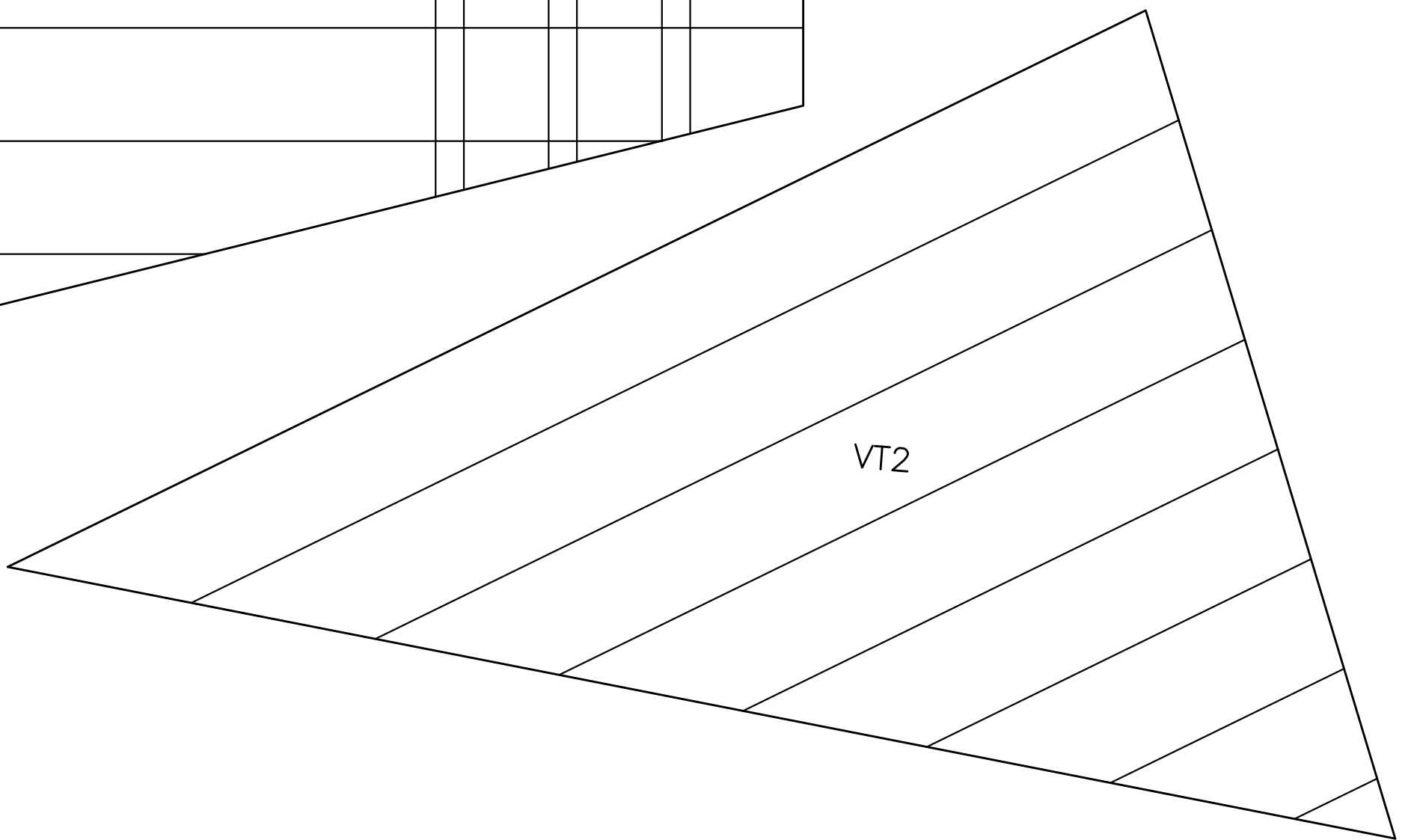
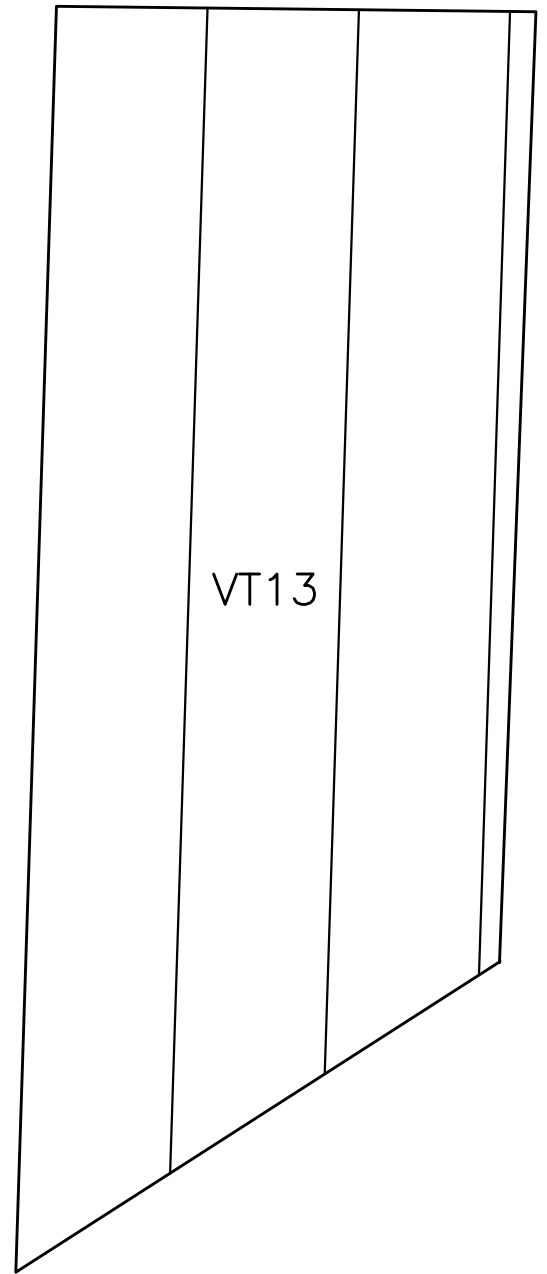
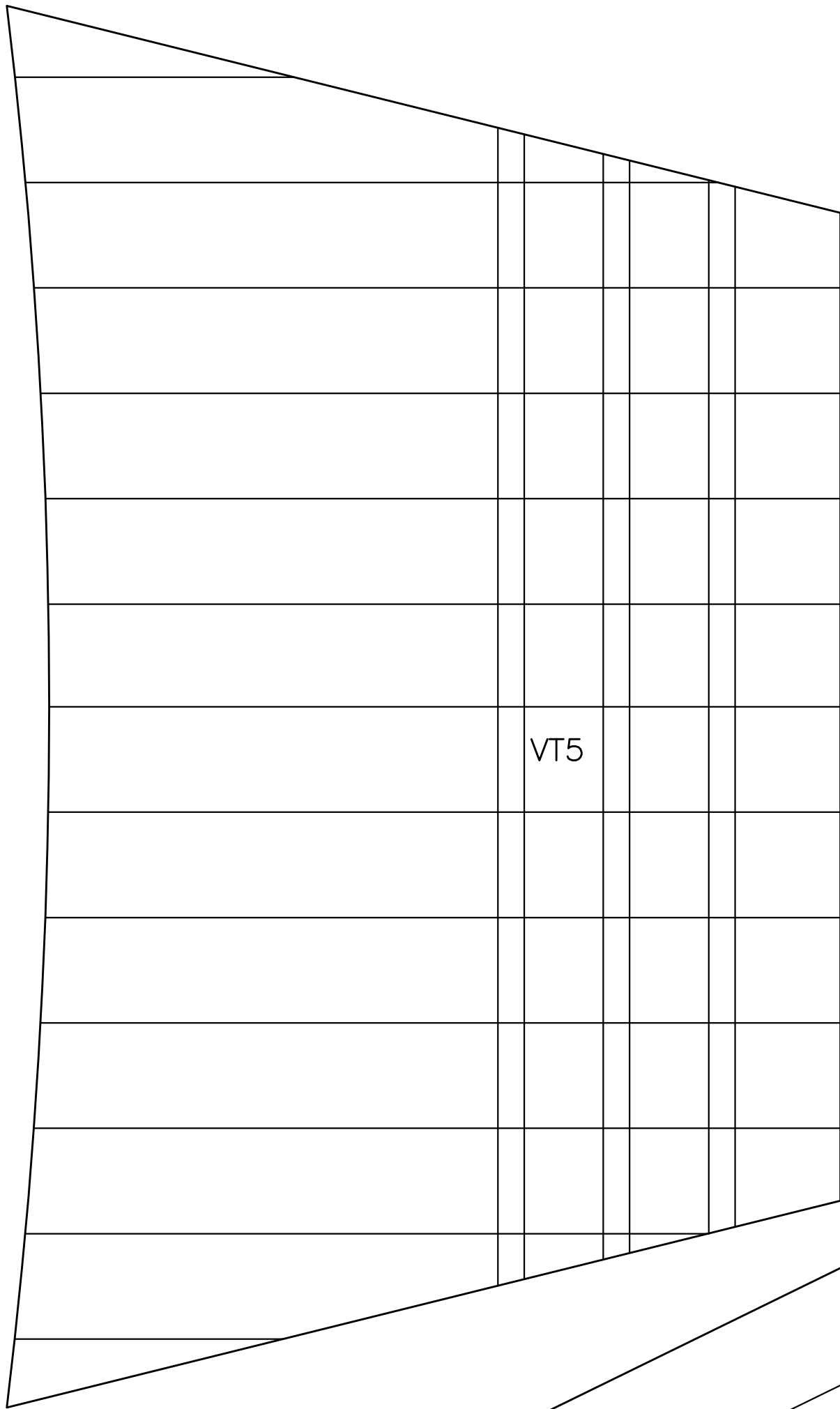

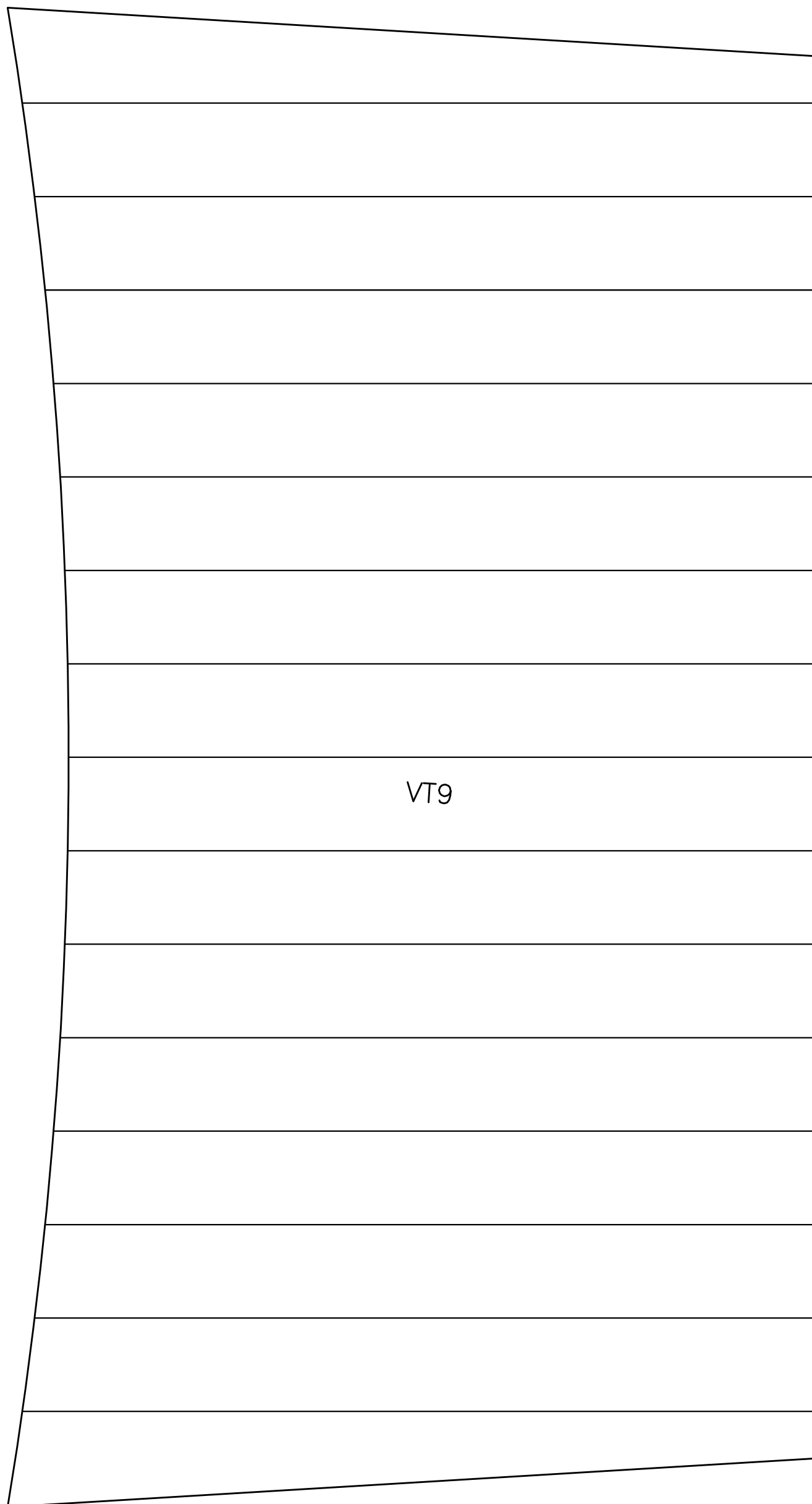

VT9

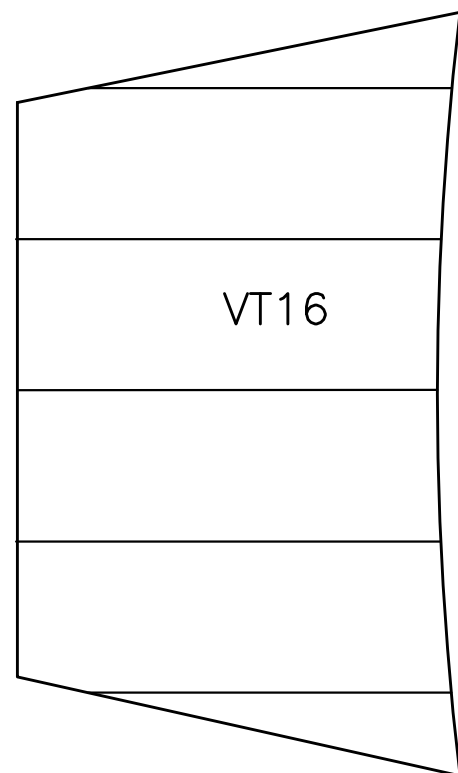
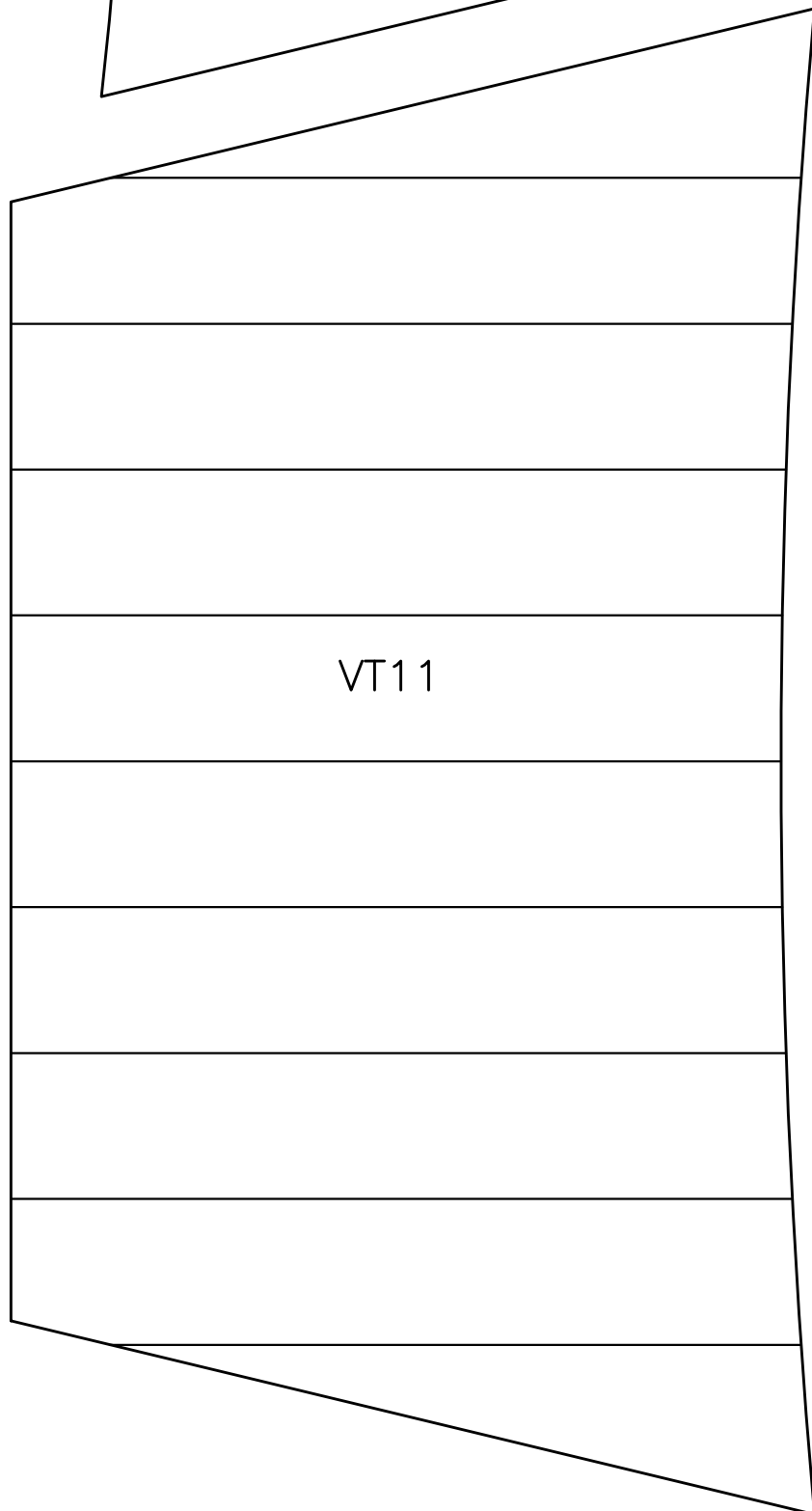
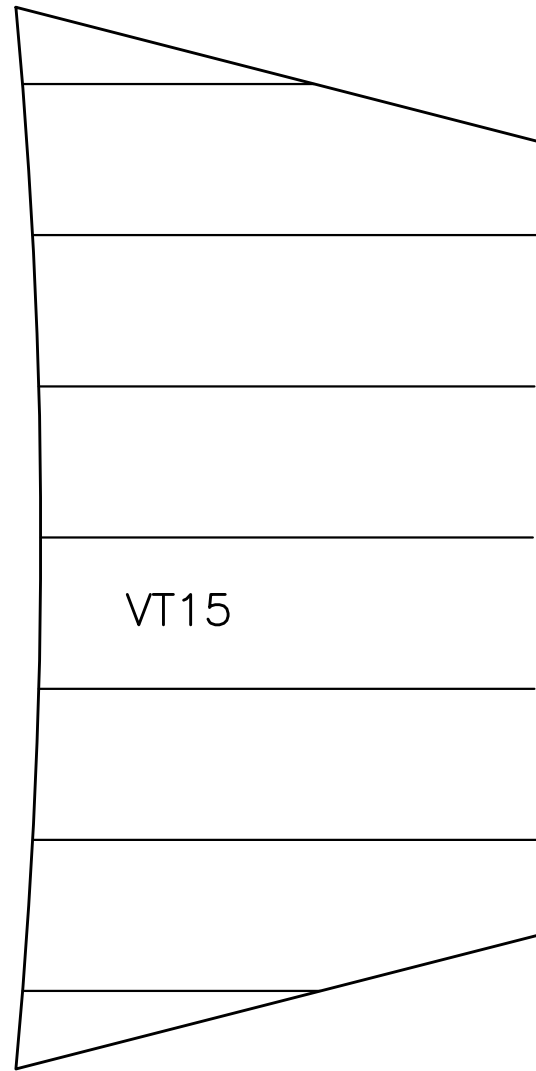
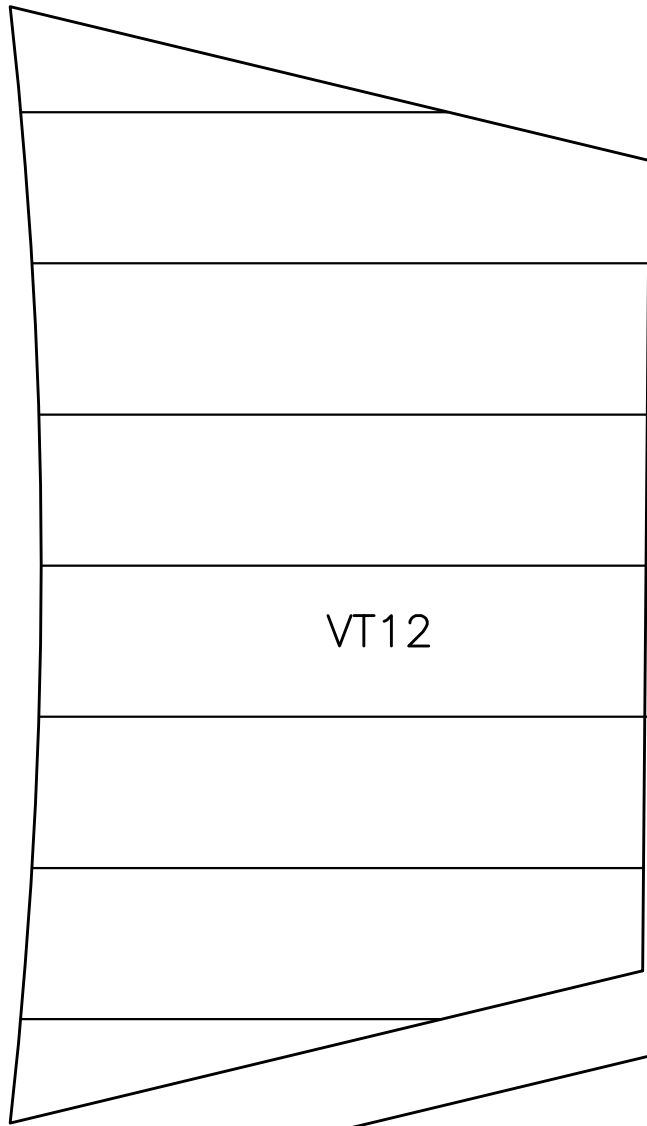

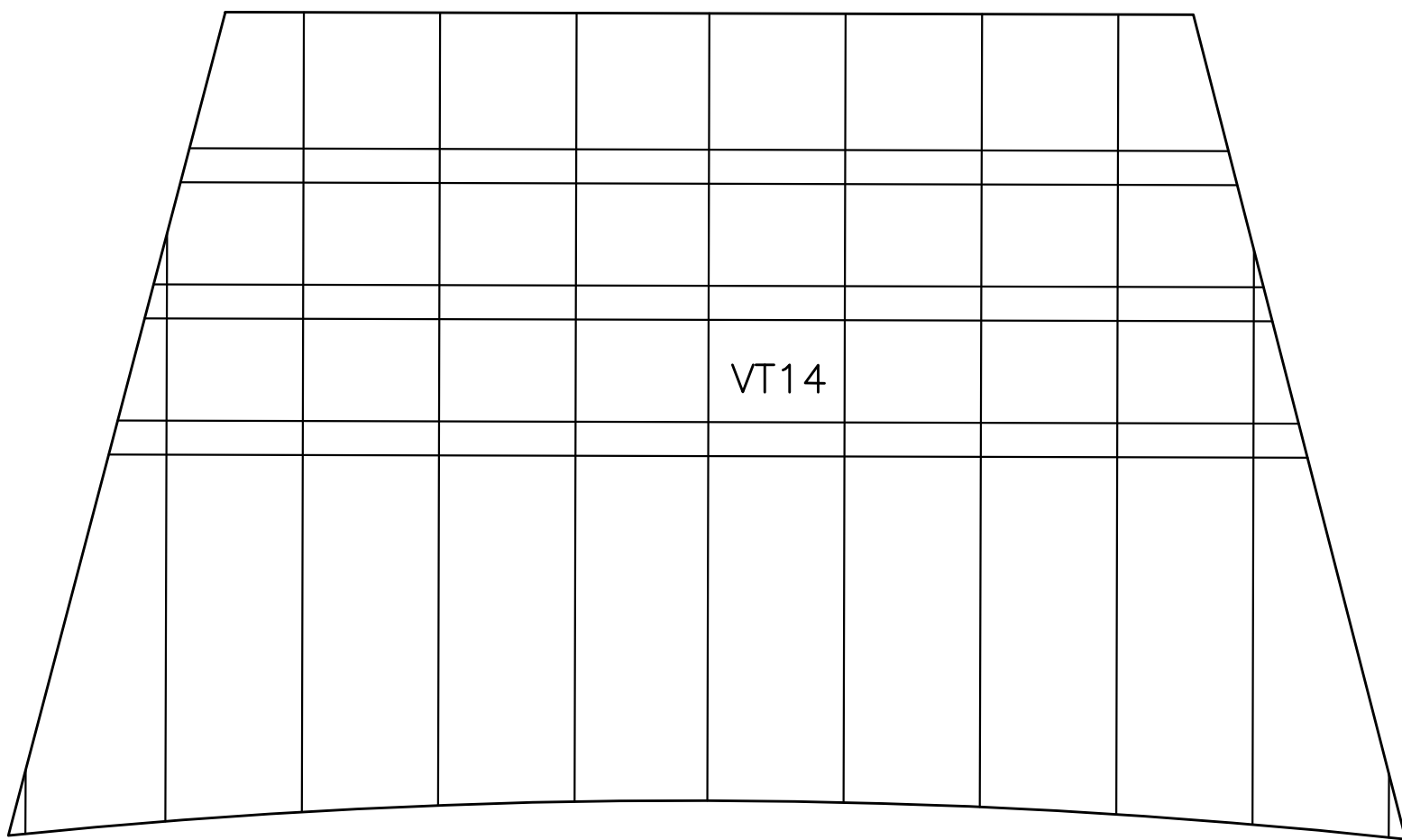
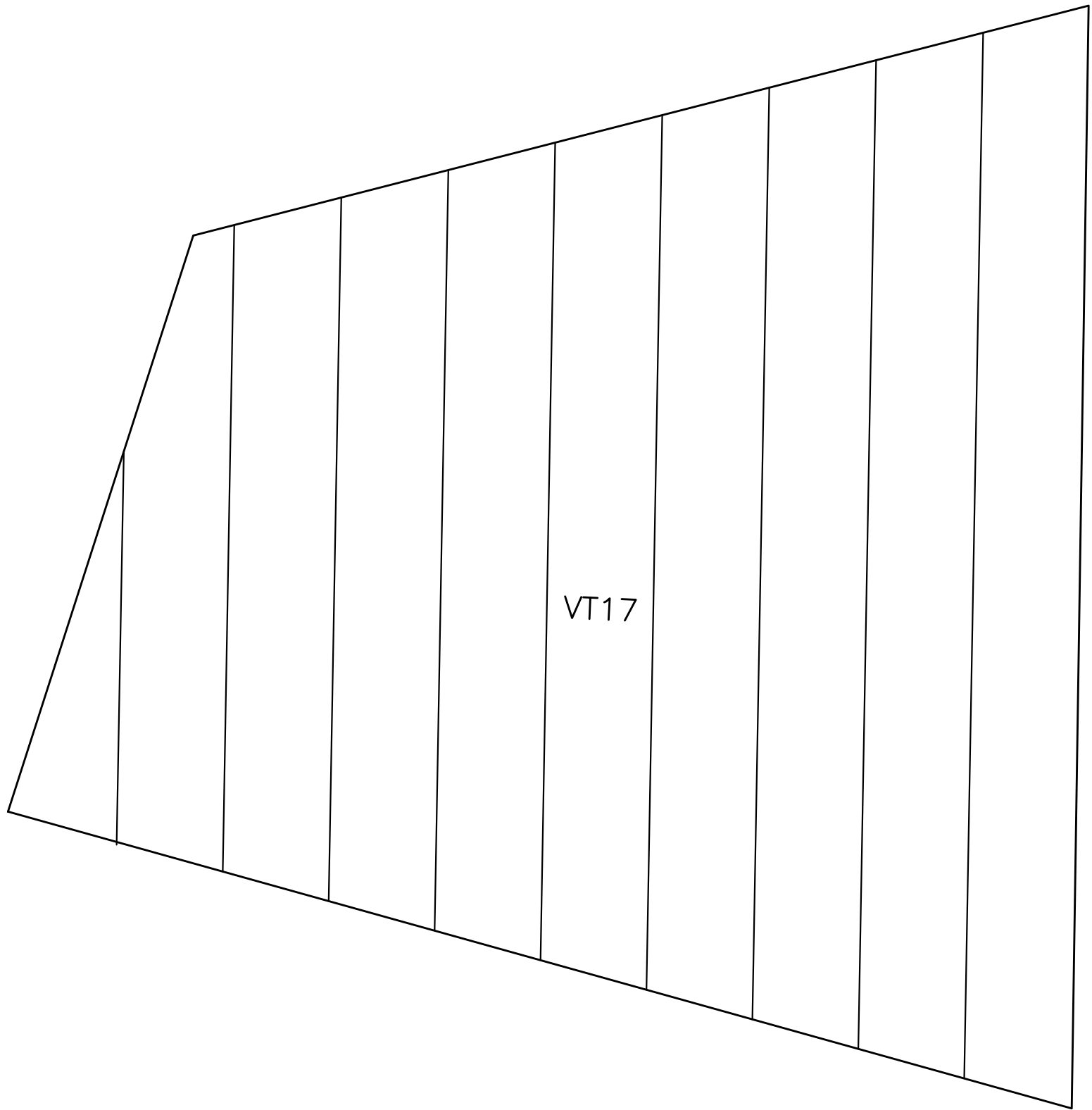

# La Belle Poule



A

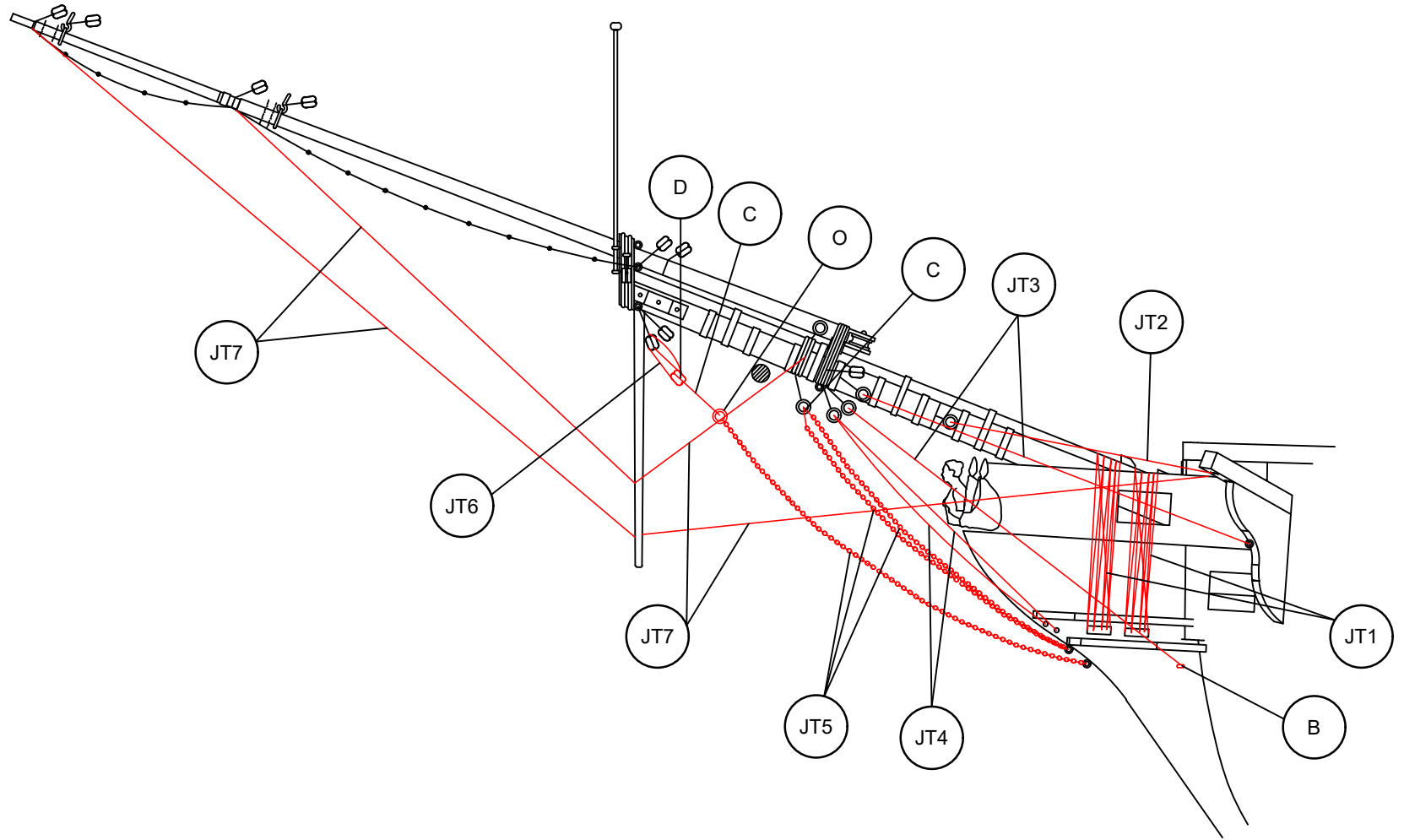

JT1	ø0,80x200	Hilo marrón / Brown thread / Fil brun / braunes Baumwollfaden / Filo marrone	JT7	ø0,50x300	Hilo marrón / Brown thread / Fil brun / braunes Baumwollfaden / Filo marrone
JT2	ø0,50x200	Hilo marrón / Brown thread / Fil brun / braunes Baumwollfaden / Filo marrone	B	15	Latón / Brass / Latón / Messing / Ottone
JT3	ø0,50x225	Hilo marrón / Brown thread / Fil brun / braunes Baumwollfaden / Filo marrone	C	ø0,15x150	Hilo crudo / Raw thread / Fil brut / Rohes Baumwollfaden / Filo crudo
JT4	ø0,15x150	Hilo marrón / Brown thread / Fil brun / braunes Baumwollfaden / Filo marrone	D	4	Madera / Wood / Bois / Holz / Legno
JT5	1x200	Latón / Brass / Latón / Messing / Ottone	O	ø4	Latón / Brass / Latón / Messing / Ottone
JT6	ø0,15x150	Hilo crudo / Raw thread / Fil brut / Rohes Baumwollfaden / Filo crudo			

B

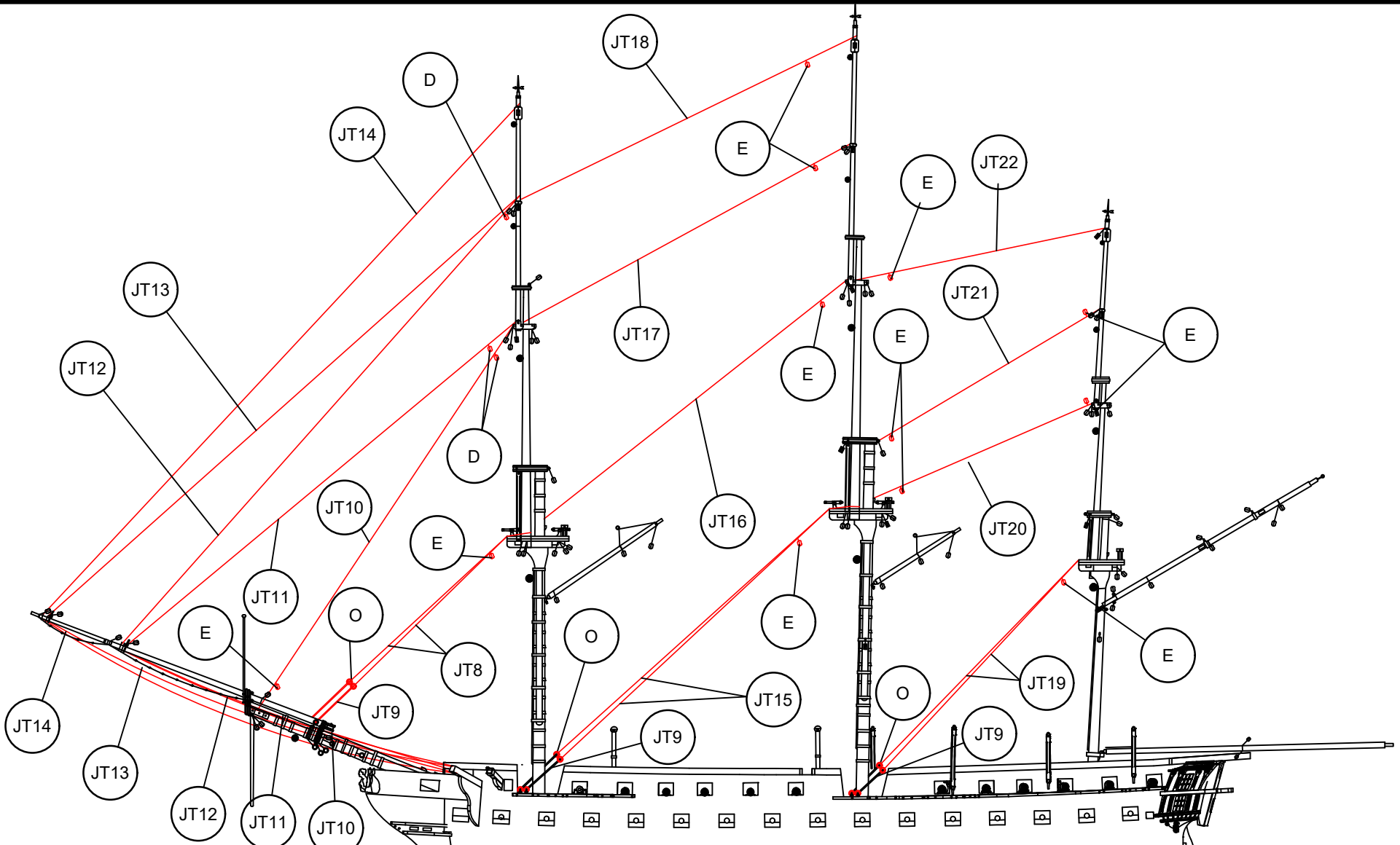

JT8	ø0,80x350	Hilo marrón / Brown thread / Fil brun / braunes Baumwollfaden / Filo marrone	JT17	ø0,80x400	Hilo marrón / Brown thread / Fil brun / braunes Baumwollfaden / Filo marrone
JT9	ø0,50x50	Latón / Brass / Latón / Messing / Ottone	JT18	ø0,80x425	Hilo marrón / Brown thread / Fil brun / braunes Baumwollfaden / Filo marrone
JT10	ø0,80x600	Hilo marrón / Brown thread / Fil brun / braunes Baumwollfaden / Filo marrone	JT19	ø0,80x300	Hilo marrón / Brown thread / Fil brun / braunes Baumwollfaden / Filo marrone
JT11	ø0,80x700	Hilo marrón / Brown thread / Fil brun / braunes Baumwollfaden / Filo marrone	JT20	ø0,80x300	Hilo marrón / Brown thread / Fil brun / braunes Baumwollfaden / Filo marrone
JT12	ø0,80x300	Hilo marrón / Brown thread / Fil brun / braunes Baumwollfaden / Filo marrone	JT21	ø0,80x650	Hilo marrón / Brown thread / Fil brun / braunes Baumwollfaden / Filo marrone
JT13	ø0,80x800	Hilo marrón / Brown thread / Fil brun / braunes Baumwollfaden / Filo marrone	JT22	ø0,80x300	Hilo marrón / Brown thread / Fil brun / braunes Baumwollfaden / Filo marrone
JT14	ø0,80x1000	Hilo marrón / Brown thread / Fil brun / braunes Baumwollfaden / Filo marrone	D	4	Madera / Wood / Bois / Holz / Legno
JT15	ø0,80x350	Hilo marrón / Brown thread / Fil brun / braunes Baumwollfaden / Filo marrone	E	4	Madera / Wood / Bois / Holz / Legno
JT16	ø0,80x350	Hilo marrón / Brown thread / Fil brun / braunes Baumwollfaden / Filo marrone	O	ø4	Latón / Brass / Latón / Messing / Ottone

# La Belle Poule



C

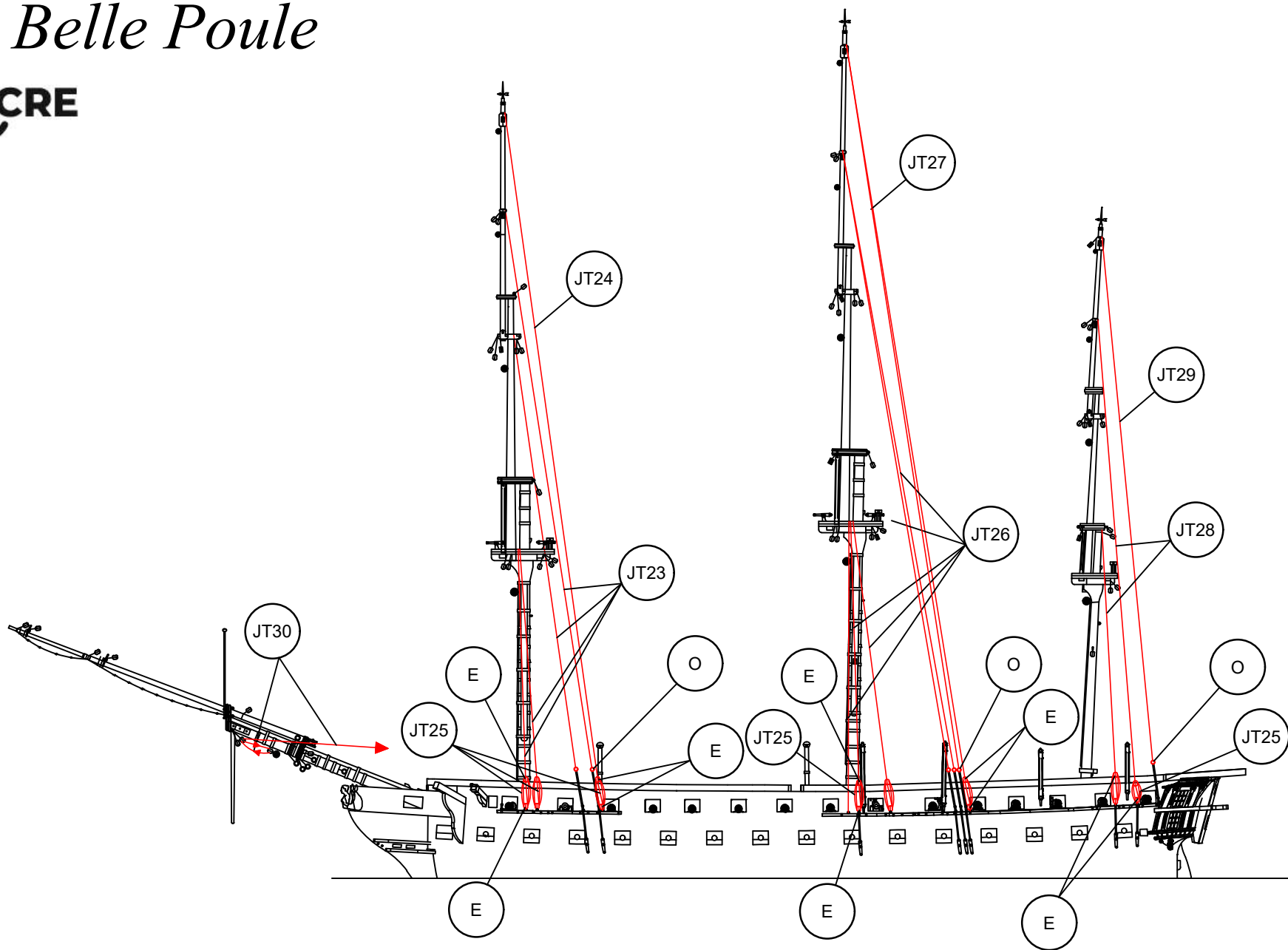

JT23	ø0,50x1000	Hilo marrón / Brown thread / Fil brun / braunes Baumwollfaden / Filo marrone	JT28	ø0,50x1000	Hilo marrón / Brown thread / Fil brun / braunes Baumwollfaden / Filo marrone
JT24	ø0,50x1200	Hilo marrón / Brown thread / Fil brun / braunes Baumwollfaden / Filo marrone	JT29	ø0,50x1200	Hilo marrón / Brown thread / Fil brun / braunes Baumwollfaden / Filo marrone
JT25	ø0,15x250	Hilo crudo / Raw thread / Fil brut / Rohes Baumwollfaden / Filo crudo	JT30	ø0,15x500	Hilo crudo / Raw thread / Fil brut / Rohes Baumwollfaden / Filo crudo
JT26	ø0,50x1100	Hilo marrón / Brown thread / Fil brun / braunes Baumwollfaden / Filo marrone	E	4	Madera / Wood / Bois / Holz / Legno
JT27	ø0,50x300	Hilo marrón / Brown thread / Fil brun / braunes Baumwollfaden / Filo marrone	O	ø4	Latón / Brass / Latón / Messing / Ottone

D

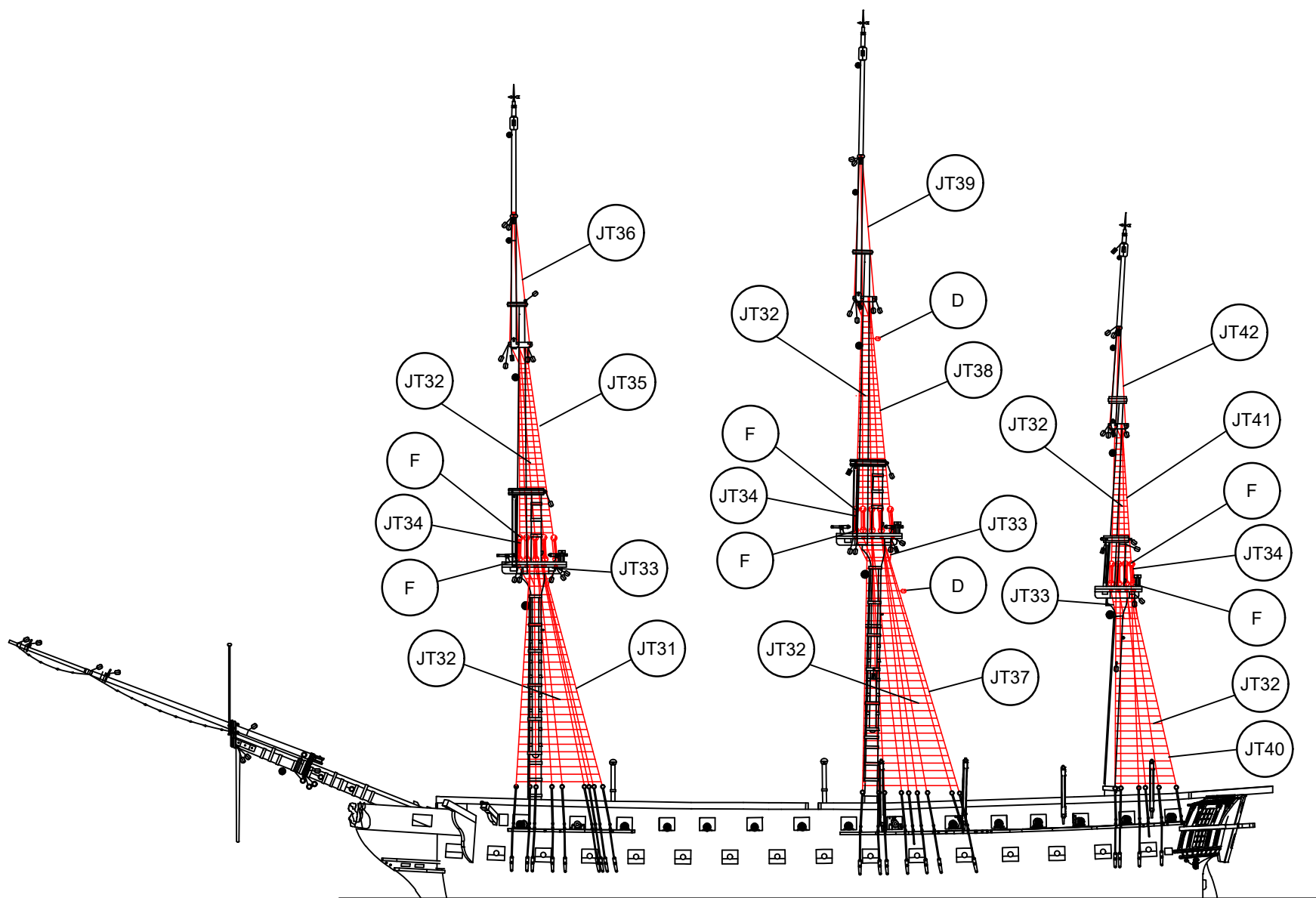

JT31	ø0,80x500	Hilo marrón / Brown thread / Fil brun / braunes Baumwollfaden / Filo marrone	JT38	ø0,80x600	Hilo marrón / Brown thread / Fil brun / braunes Baumwollfaden / Filo marrone
JT32	ø0,15x150	Hilo crudo / Raw thread / Fil brut / Rohes Baumwollfaden / Filo crudo	JT39	ø0,50x500	Hilo marrón / Brown thread / Fil brun / braunes Baumwollfaden / Filo marrone
JT33	ø0,50x120	Hilo marrón / Brown thread / Fil brun / braunes Baumwollfaden / Filo marrone	JT40	ø0,80x650	Hilo marrón / Brown thread / Fil brun / braunes Baumwollfaden / Filo marrone
JT34	ø0,15x250	Hilo crudo / Raw thread / Fil brut / Rohes Baumwollfaden / Filo crudo	JT41	ø0,80x500	Hilo marrón / Brown thread / Fil brun / braunes Baumwollfaden / Filo marrone
JT35	ø0,80x475	Hilo marrón / Brown thread / Fil brun / braunes Baumwollfaden / Filo marrone	JT42	ø0,50x450	Hilo marrón / Brown thread / Fil brun / braunes Baumwollfaden / Filo marrone
JT36	ø0,50x475	Hilo marrón / Brown thread / Fil brun / braunes Baumwollfaden / Filo marrone	D	4	Madera / Wood / Bois / Holz / Legno
JT37	ø0,80x700	Hilo marrón / Brown thread / Fil brun / braunes Baumwollfaden / Filo marrone	F	ø4	Madera / Wood / Bois / Holz / Legno

# La Belle Poule

OCCRE

E

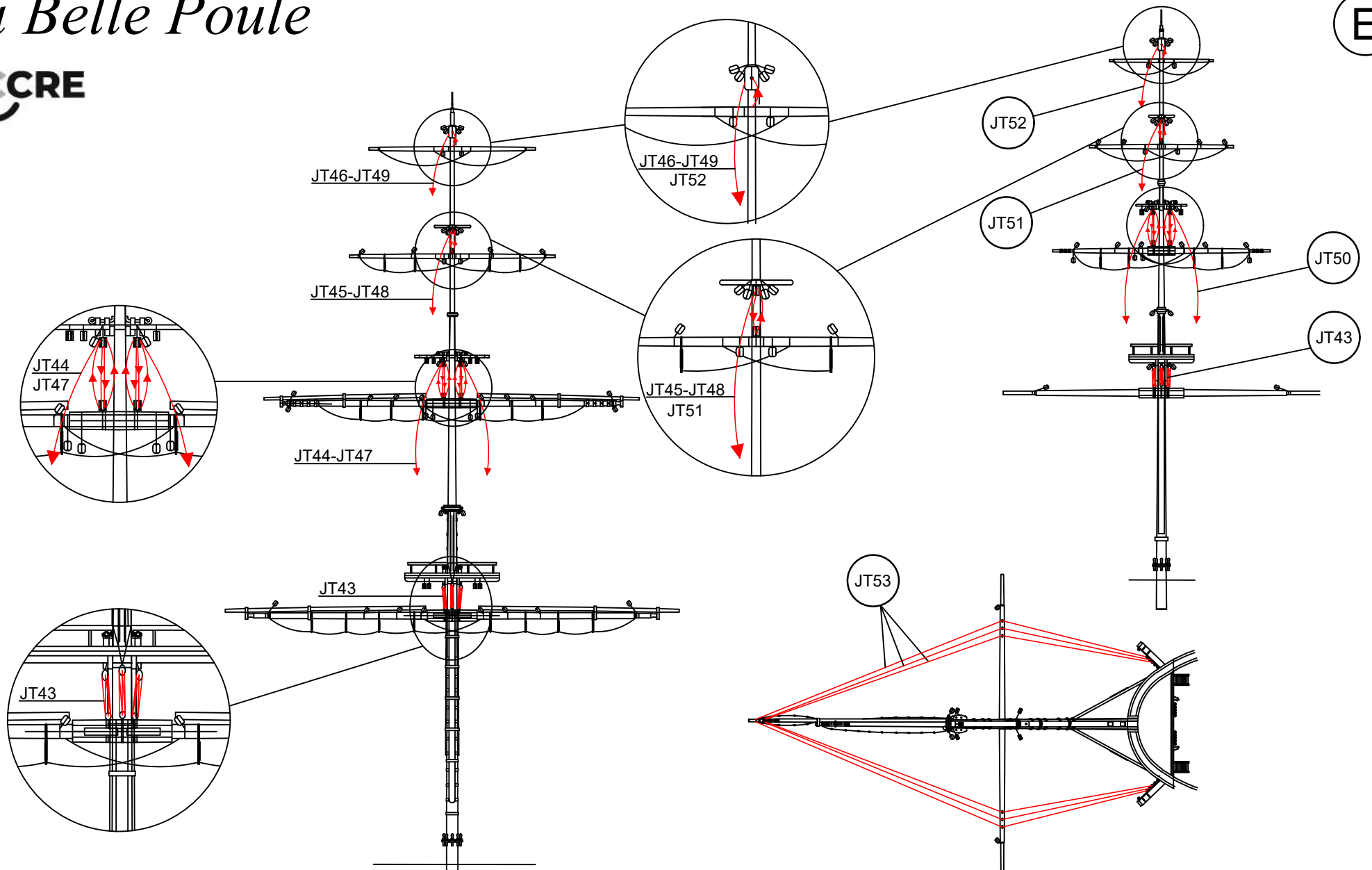

JT43	∅0,50x200	Hilo marrón / Brown thread / Fil brun / braunes Baumwollfaden / Filo marrone	JT49	∅0,15x550	Hilo crudo / Raw thread / Fil brut / Rohes Baumwollfaden / Filo crudo
JT44	∅0,15x400	Hilo crudo / Raw thread / Fil brut / Rohes Baumwollfaden / Filo crudo	JT50	∅0,15x400	Hilo crudo / Raw thread / Fil brut / Rohes Baumwollfaden / Filo crudo
JT45	∅0,15x550	Hilo crudo / Raw thread / Fil brut / Rohes Baumwollfaden / Filo crudo	JT51	∅0,15x500	Hilo crudo / Raw thread / Fil brut / Rohes Baumwollfaden / Filo crudo
JT46	∅0,15x700	Hilo crudo / Raw thread / Fil brut / Rohes Baumwollfaden / Filo crudo	JT52	∅0,15x500	Hilo crudo / Raw thread / Fil brut / Rohes Baumwollfaden / Filo crudo
JT47	∅0,15x600	Hilo crudo / Raw thread / Fil brut / Rohes Baumwollfaden / Filo crudo	JT53	∅0,15x600	Hilo crudo / Raw thread / Fil brut / Rohes Baumwollfaden / Filo crudo
JT48	∅0,15x675	Hilo crudo / Raw thread / Fil brut / Rohes Baumwollfaden / Filo crudo			

F

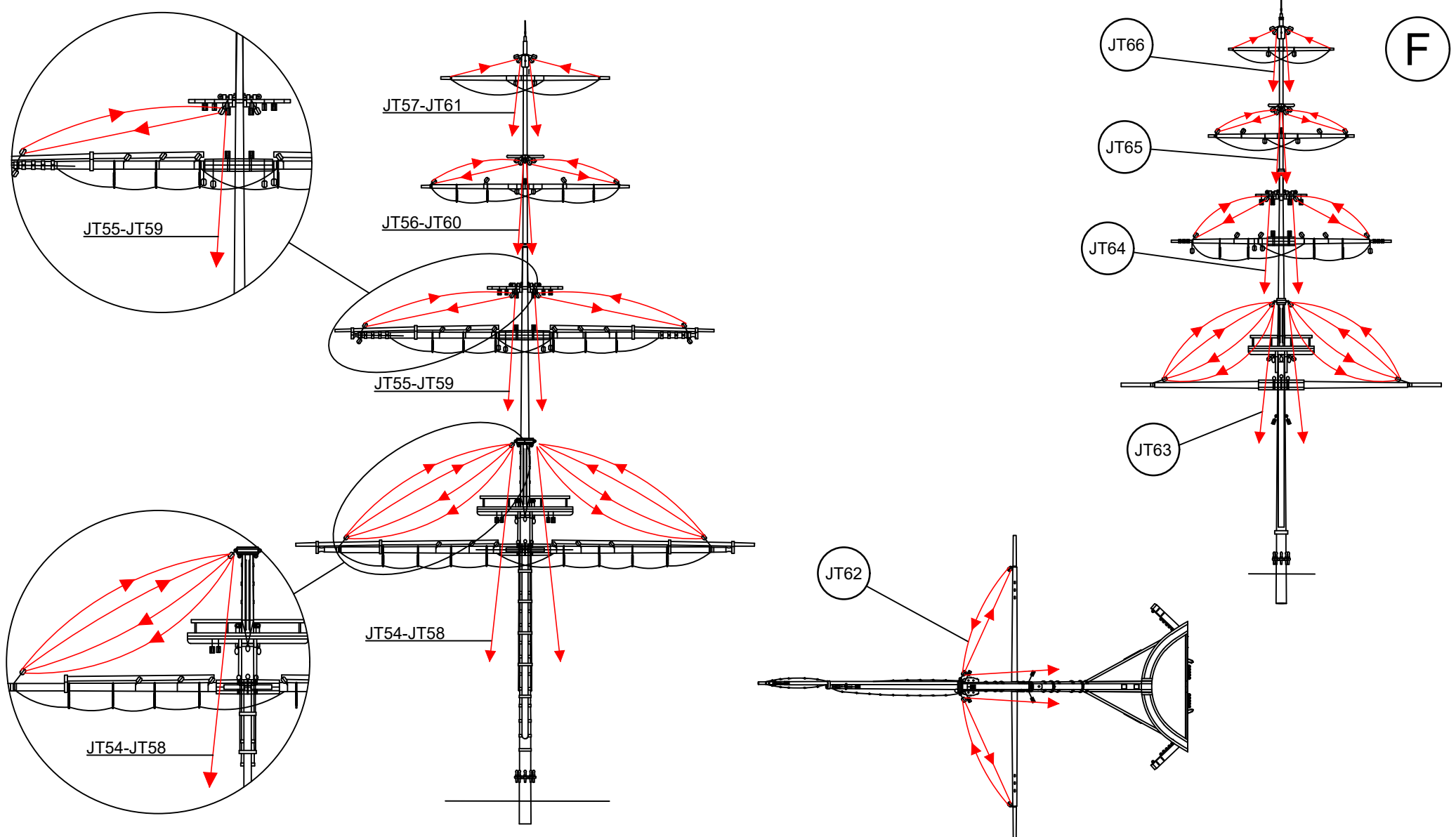

JT54	∅0,15x950	Hilo crudo / Raw thread / Fil brut / Rohes Baumwollfaden / Filo crudo	JT61	∅0,15x950	Hilo crudo / Raw thread / Fil brut / Rohes Baumwollfaden / Filo crudo
JT55	∅0,15x700	Hilo crudo / Raw thread / Fil brut / Rohes Baumwollfaden / Filo crudo	JT62	∅0,15x550	Hilo crudo / Raw thread / Fil brut / Rohes Baumwollfaden / Filo crudo
JT56	∅0,15x800	Hilo crudo / Raw thread / Fil brut / Rohes Baumwollfaden / Filo crudo	JT63	∅0,15x600	Hilo crudo / Raw thread / Fil brut / Rohes Baumwollfaden / Filo crudo
JT57	∅0,15x110	Hilo crudo / Raw thread / Fil brut / Rohes Baumwollfaden / Filo crudo	JT64	∅0,15x700	Hilo crudo / Raw thread / Fil brut / Rohes Baumwollfaden / Filo crudo
JT58	∅0,15x850	Hilo crudo / Raw thread / Fil brut / Rohes Baumwollfaden / Filo crudo	JT65	∅0,15x700	Hilo crudo / Raw thread / Fil brut / Rohes Baumwollfaden / Filo crudo
JT59	∅0,15x900	Hilo crudo / Raw thread / Fil brut / Rohes Baumwollfaden / Filo crudo	JT66	∅0,15x600	Hilo crudo / Raw thread / Fil brut / Rohes Baumwollfaden / Filo crudo
JT60	∅0,15x800	Hilo crudo / Raw thread / Fil brut / Rohes Baumwollfaden / Filo crudo			

# La Belle Poule



Aparejo de velas / Sail rig / Gréement  
Segel takelage / Sartiame da vela

G

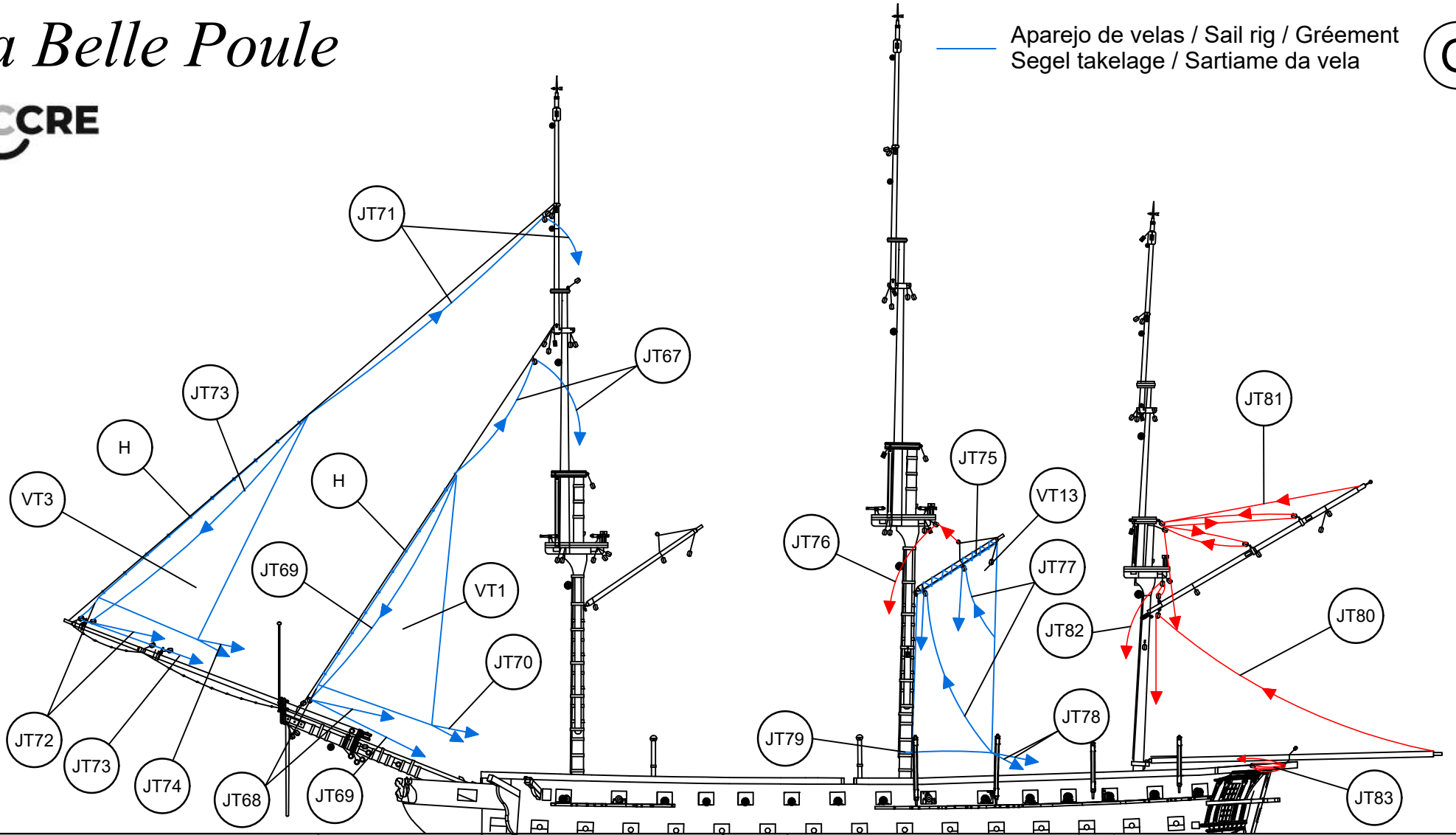

VT1	Preformado / Preformed/ Préformé / Vorgeformt / Preformato	Tela / Cloth / Étoffe / Stoff / Tela	JT75	∅0,15x1000	Hilo crudo / Raw thread / Fil brut / Rohes Baumwollfaden / Filo crudo
JT67	∅0,15x750	Hilo crudo / Raw thread / Fil brut / Rohes Baumwollfaden / Filo crudo	JT76	∅0,15x400	Hilo crudo / Raw thread / Fil brut / Rohes Baumwollfaden / Filo crudo
JT68	∅0,15x300	Hilo crudo / Raw thread / Fil brut / Rohes Baumwollfaden / Filo crudo	JT77	∅0,15x500	Hilo crudo / Raw thread / Fil brut / Rohes Baumwollfaden / Filo crudo
JT69	∅0,15x500	Hilo crudo / Raw thread / Fil brut / Rohes Baumwollfaden / Filo crudo	JT78	∅0,15x250	Hilo crudo / Raw thread / Fil brut / Rohes Baumwollfaden / Filo crudo
JT70	∅0,15x300	Hilo crudo / Raw thread / Fil brut / Rohes Baumwollfaden / Filo crudo	JT79	∅0,15x150	Hilo crudo / Raw thread / Fil brut / Rohes Baumwollfaden / Filo crudo
VT3	Preformado / Preformed/ Préformé / Vorgeformt / Preformato	Tela / Cloth / Étoffe / Stoff / Tela	JT80	∅0,15x500	Hilo crudo / Raw thread / Fil brut / Rohes Baumwollfaden / Filo crudo
JT71	∅0,15x700	Hilo crudo / Raw thread / Fil brut / Rohes Baumwollfaden / Filo crudo	JT81	∅0,15x550	Hilo crudo / Raw thread / Fil brut / Rohes Baumwollfaden / Filo crudo
JT72	∅0,15x400	Hilo crudo / Raw thread / Fil brut / Rohes Baumwollfaden / Filo crudo	JT82	∅0,15x400	Hilo crudo / Raw thread / Fil brut / Rohes Baumwollfaden / Filo crudo
JT73	∅0,15x850	Hilo crudo / Raw thread / Fil brut / Rohes Baumwollfaden / Filo crudo	JT83	∅0,15x350	Hilo crudo / Raw thread / Fil brut / Rohes Baumwollfaden / Filo crudo
JT74	∅0,15x350	Hilo crudo / Raw thread / Fil brut / Rohes Baumwollfaden / Filo crudo	H	∅3	Latón / Brass / Latón / Messing / Ottone
VT13	Preformado / Preformed/ Préformé / Vorgeformt / Preformato	Tela / Cloth / Étoffe / Stoff / Tela			

H

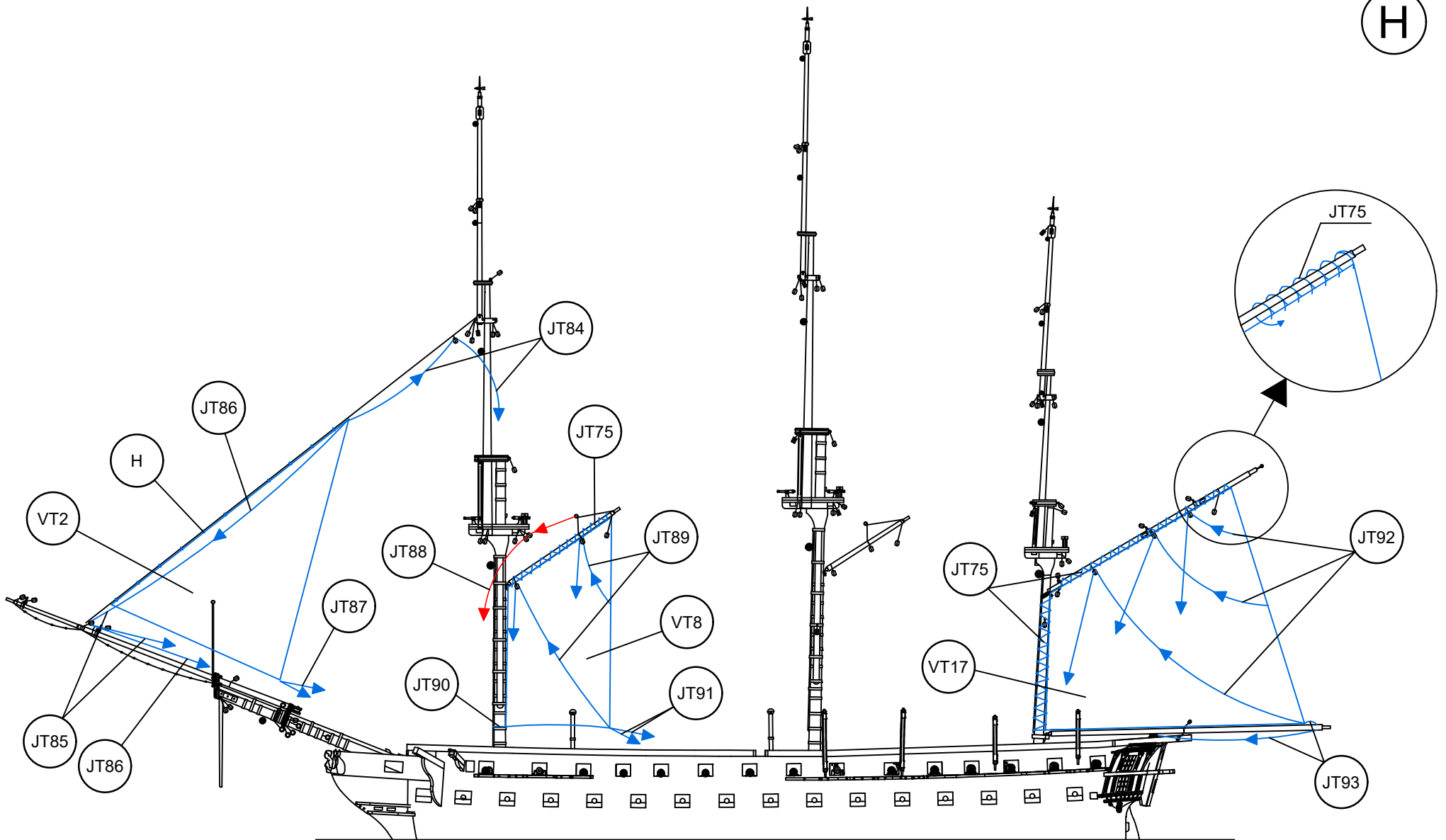

VT2	Preformado / Preformed/ Préformé / Vorgeformt / Preformato	Tela / Cloth / Étoffe / Stoff / Tela	JT89	∅0,15x500	Hilo crudo / Raw thread / Fil brut / Rohes Baumwollfaden / Filo crudo
JT84	∅0,15x1000	Hilo crudo / Raw thread / Fil brut / Rohes Baumwollfaden / Filo crudo	JT90	∅0,15x200	Hilo crudo / Raw thread / Fil brut / Rohes Baumwollfaden / Filo crudo
JT85	∅0,15x800	Hilo crudo / Raw thread / Fil brut / Rohes Baumwollfaden / Filo crudo	JT91	∅0,15x300	Hilo crudo / Raw thread / Fil brut / Rohes Baumwollfaden / Filo crudo
JT86	∅0,15x900	Hilo crudo / Raw thread / Fil brut / Rohes Baumwollfaden / Filo crudo	VT17	Preformado / Preformed/ Préformé / Vorgeformt / Preformato	Tela / Cloth / Étoffe / Stoff / Tela
JT87	∅0,15x400	Hilo crudo / Raw thread / Fil brut / Rohes Baumwollfaden / Filo crudo	JT92	∅0,15x600	Hilo crudo / Raw thread / Fil brut / Rohes Baumwollfaden / Filo crudo
VT8	Preformado / Preformed/ Préformé / Vorgeformt / Preformato	Tela / Cloth / Étoffe / Stoff / Tela	JT93	∅0,15x300	Hilo crudo / Raw thread / Fil brut / Rohes Baumwollfaden / Filo crudo
JT88	∅0,15x400	Hilo crudo / Raw thread / Fil brut / Rohes Baumwollfaden / Filo crudo	H	∅3	Latón / Brass / Latón / Messing / Ottone

# La Belle Poule



Aparejo de velas / Sail rig / Gréement  
Segel takelage / Sartame da vela

I

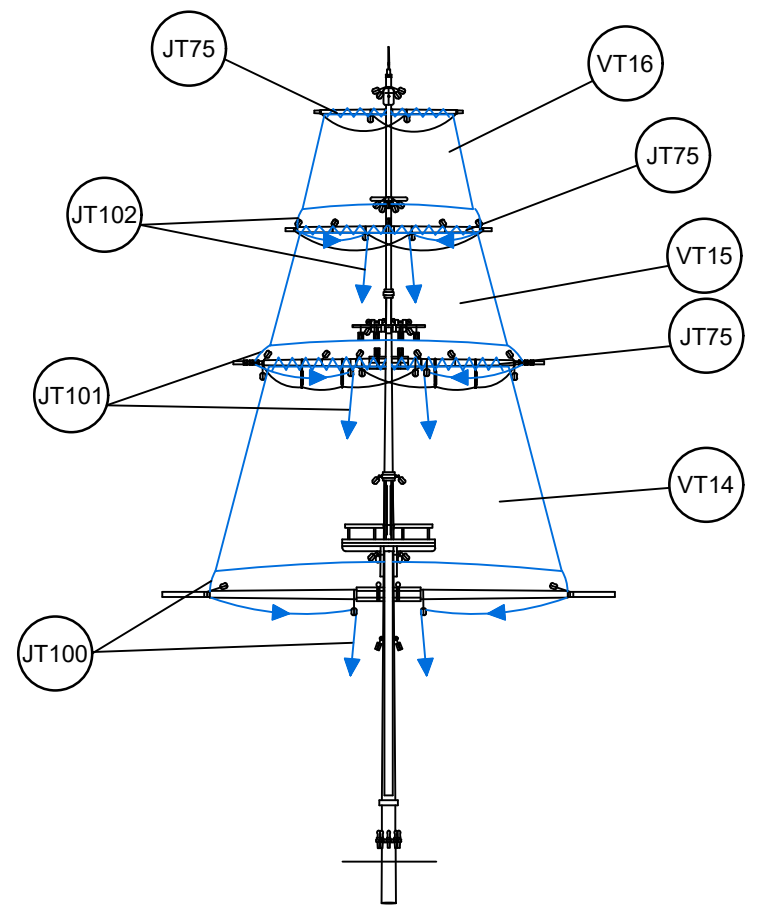
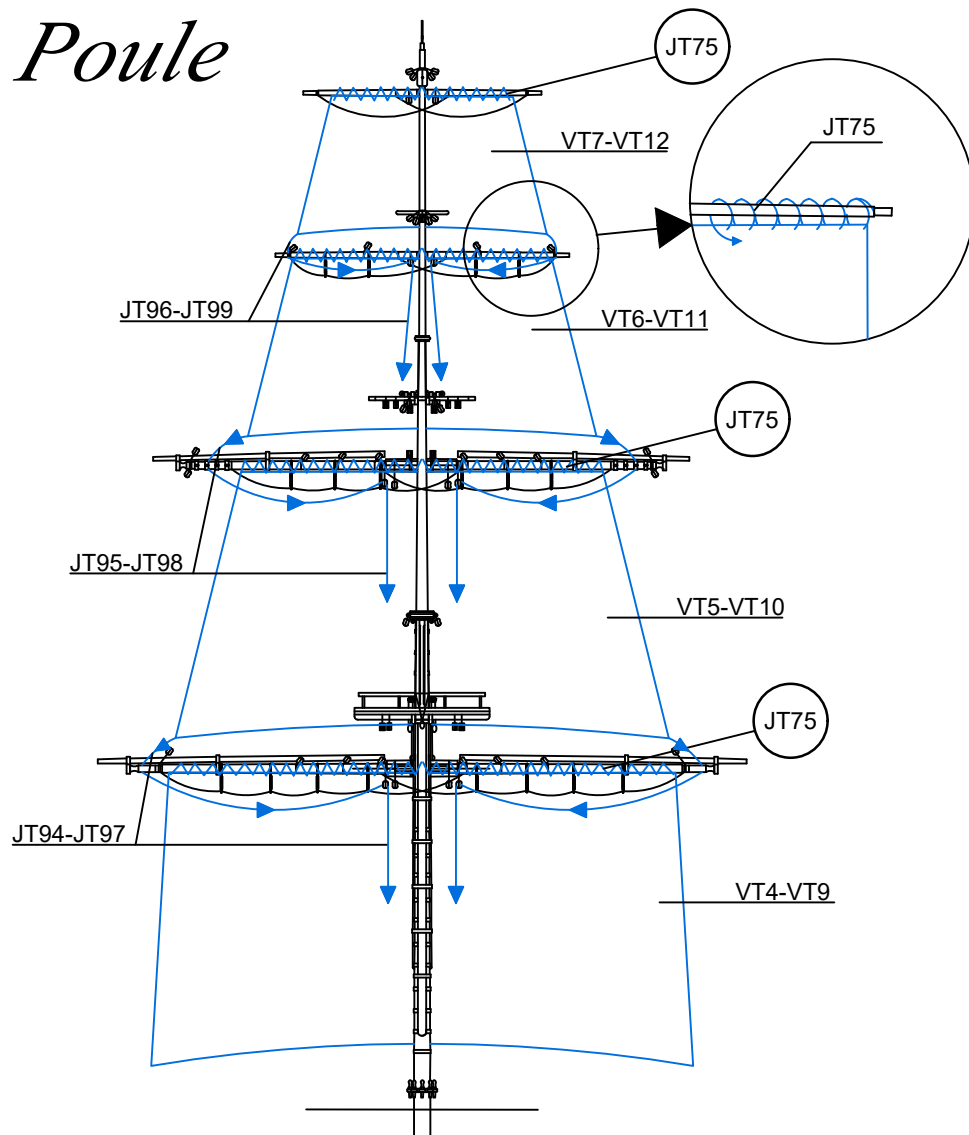

VT4	Preformado / Prefomed/ Préformé / Vorgeformt / Preformato	Tela / Cloth / Étoffe / Stoff / Tela	VT11	Preformado / Prefomed/ Préformé / Vorgeformt / Preformato	Tela / Cloth / Étoffe / Stoff / Tela
VT5	Preformado / Prefomed/ Préformé / Vorgeformt / Preformato	Tela / Cloth / Étoffe / Stoff / Tela	JT98	∅0,15x750	Hilo crudo / Raw thread / Fil brut / Rohes Baumwollfaden / Filo crudo
JT94	∅0,15x500	Hilo crudo / Raw thread / Fil brut / Rohes Baumwollfaden / Filo crudo	VT12	Preformado / Prefomed/ Préformé / Vorgeformt / Preformato	Tela / Cloth / Étoffe / Stoff / Tela
VT6	Preformado / Prefomed/ Préformé / Vorgeformt / Preformato	Tela / Cloth / Étoffe / Stoff / Tela	JT99	∅0,15x950	Hilo crudo / Raw thread / Fil brut / Rohes Baumwollfaden / Filo crudo
JT95	∅0,15x650	Hilo crudo / Raw thread / Fil brut / Rohes Baumwollfaden / Filo crudo	VT14	Preformado / Prefomed/ Préformé / Vorgeformt / Preformato	Tela / Cloth / Étoffe / Stoff / Tela
VT7	Preformado / Prefomed/ Préformé / Vorgeformt / Preformato	Tela / Cloth / Étoffe / Stoff / Tela	JT100	∅0,15x650	Hilo crudo / Raw thread / Fil brut / Rohes Baumwollfaden / Filo crudo
JT96	∅0,15x800	Hilo crudo / Raw thread / Fil brut / Rohes Baumwollfaden / Filo crudo	VT15	Preformado / Prefomed/ Préformé / Vorgeformt / Preformato	Tela / Cloth / Étoffe / Stoff / Tela
VT9	Preformado / Prefomed/ Préformé / Vorgeformt / Preformato	Tela / Cloth / Étoffe / Stoff / Tela	JT101	∅0,15x650	Hilo crudo / Raw thread / Fil brut / Rohes Baumwollfaden / Filo crudo
VT10	Preformado / Prefomed/ Préformé / Vorgeformt / Preformato	Tela / Cloth / Étoffe / Stoff / Tela	VT16	Preformado / Prefomed/ Préformé / Vorgeformt / Preformato	Tela / Cloth / Étoffe / Stoff / Tela
JT97	∅0,15x600	Hilo crudo / Raw thread / Fil brut / Rohes Baumwollfaden / Filo crudo	JT102	∅0,15x650	Hilo crudo / Raw thread / Fil brut / Rohes Baumwollfaden / Filo crudo

J

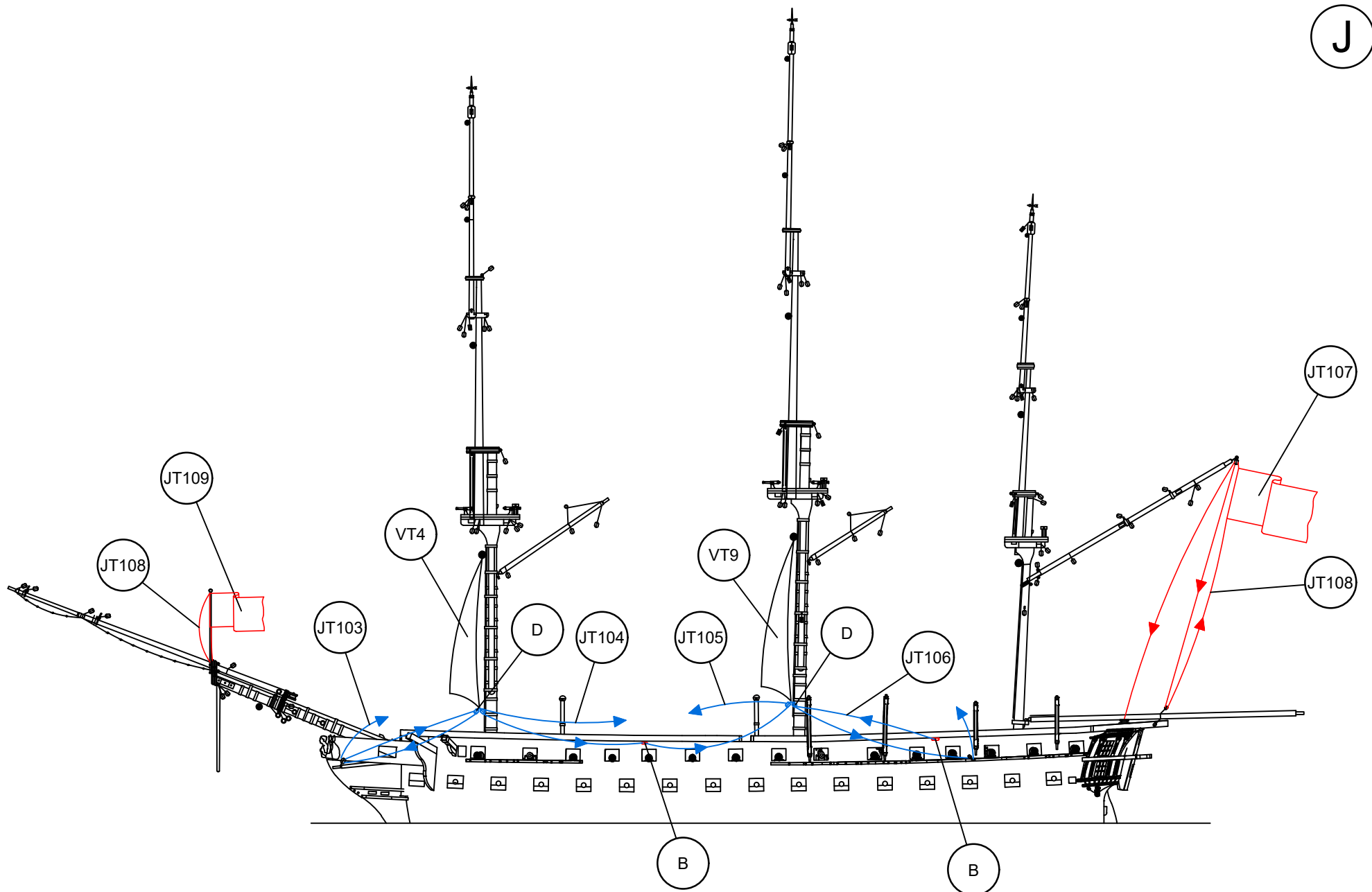

JT103	∅0,15x650	Hilo crudo / Raw thread / Fil brut / Rohes Baumwollfaden / Filo crudo	JT108	∅0,15x600	Hilo crudo / Raw thread / Fil brut / Rohes Baumwollfaden / Filo crudo
JT104	∅0,15x600	Hilo crudo / Raw thread / Fil brut / Rohes Baumwollfaden / Filo crudo	JT109	Preformado / Prefomed/ Préformé / Vorgeformt / Preformato	Tela / Cloth / Étoffe / Stoff / Tela
JT105	∅0,15x650	Hilo crudo / Raw thread / Fil brut / Rohes Baumwollfaden / Filo crudo	B	15	Latón / Brass / Latón / Messing / Ottone
JT106	∅0,15x600	Hilo crudo / Raw thread / Fil brut / Rohes Baumwollfaden / Filo crudo	D	4	Madera / Wood / Bois / Holz / Legno
JT107	Preformado / Prefomed/ Préformé / Vorgeformt / Preformato	Tela / Cloth / Étoffe / Stoff / Tela			

# La Belle Poule

OCCRE

Aparejo de velas / Sail rig / Gréement  
Segel takelage / Sartiamе da vela

K

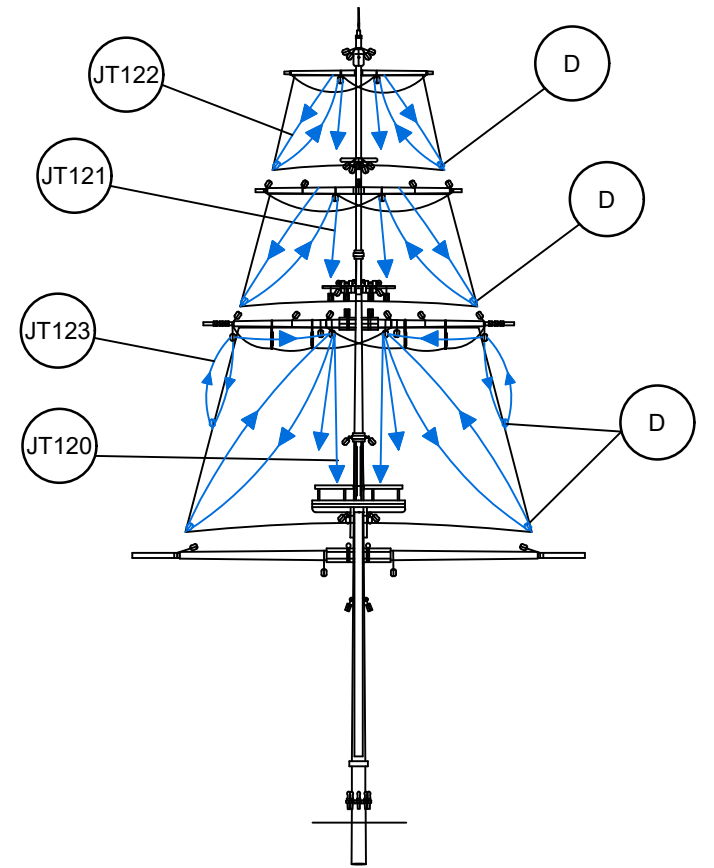
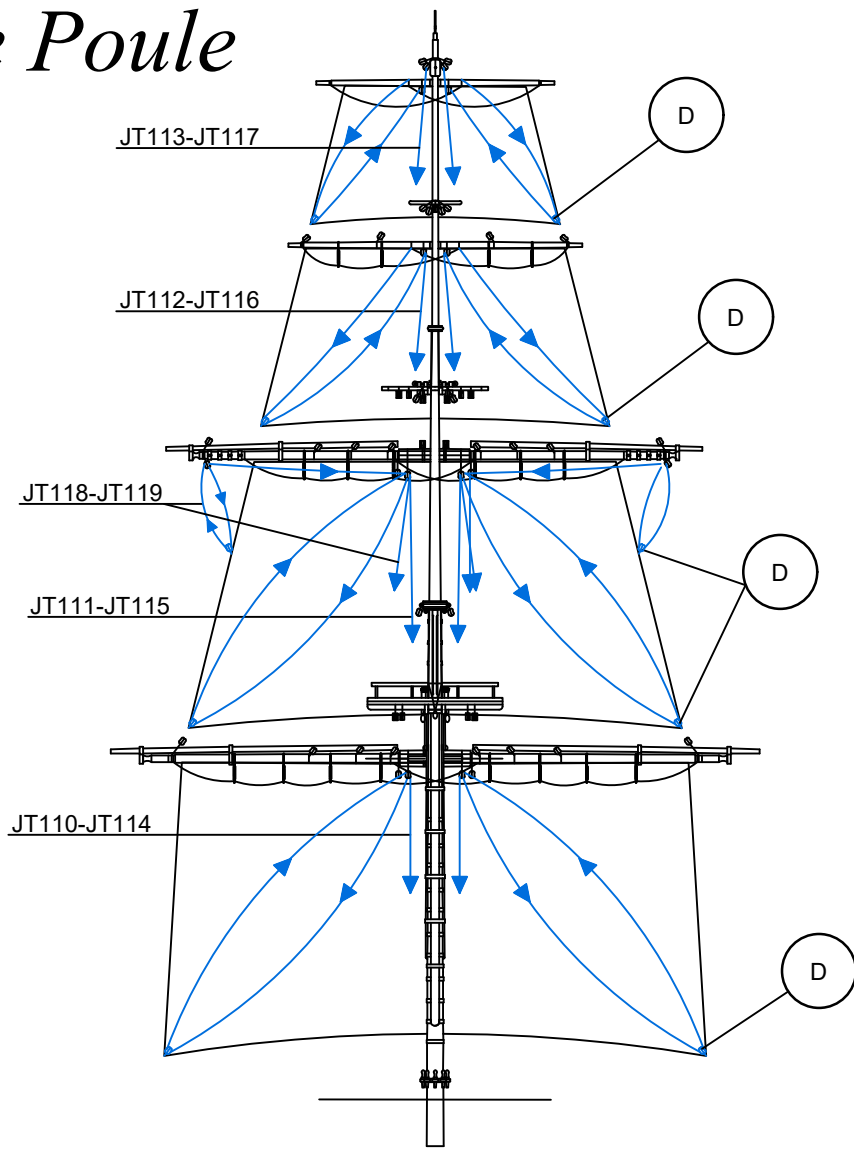

JT110	ø0,15x700	Hilo crudo / Raw thread / Fil brut / Rohes Baumwollfaden / Filo crudo	JT118	ø0,15x600	Hilo crudo / Raw thread / Fil brut / Rohes Baumwollfaden / Filo crudo
JT111	ø0,15x900	Hilo crudo / Raw thread / Fil brut / Rohes Baumwollfaden / Filo crudo	JT119	ø0,15x700	Hilo crudo / Raw thread / Fil brut / Rohes Baumwollfaden / Filo crudo
JT112	ø0,15x1100	Hilo crudo / Raw thread / Fil brut / Rohes Baumwollfaden / Filo crudo	JT120	ø0,15x750	Hilo crudo / Raw thread / Fil brut / Rohes Baumwollfaden / Filo crudo
JT113	ø0,15x1200	Hilo crudo / Raw thread / Fil brut / Rohes Baumwollfaden / Filo crudo	JT121	ø0,15x900	Hilo crudo / Raw thread / Fil brut / Rohes Baumwollfaden / Filo crudo
JT114	ø0,15x800	Hilo crudo / Raw thread / Fil brut / Rohes Baumwollfaden / Filo crudo	JT122	ø0,15x1000	Hilo crudo / Raw thread / Fil brut / Rohes Baumwollfaden / Filo crudo
JT115	ø0,15x950	Hilo crudo / Raw thread / Fil brut / Rohes Baumwollfaden / Filo crudo	JT123	ø0,15x650	Hilo crudo / Raw thread / Fil brut / Rohes Baumwollfaden / Filo crudo
JT116	ø0,15x1100	Hilo crudo / Raw thread / Fil brut / Rohes Baumwollfaden / Filo crudo	D	4	Madera / Wood / Bois / Holz / Legno
JT117	ø0,15x1300	Hilo crudo / Raw thread / Fil brut / Rohes Baumwollfaden / Filo crudo			

L

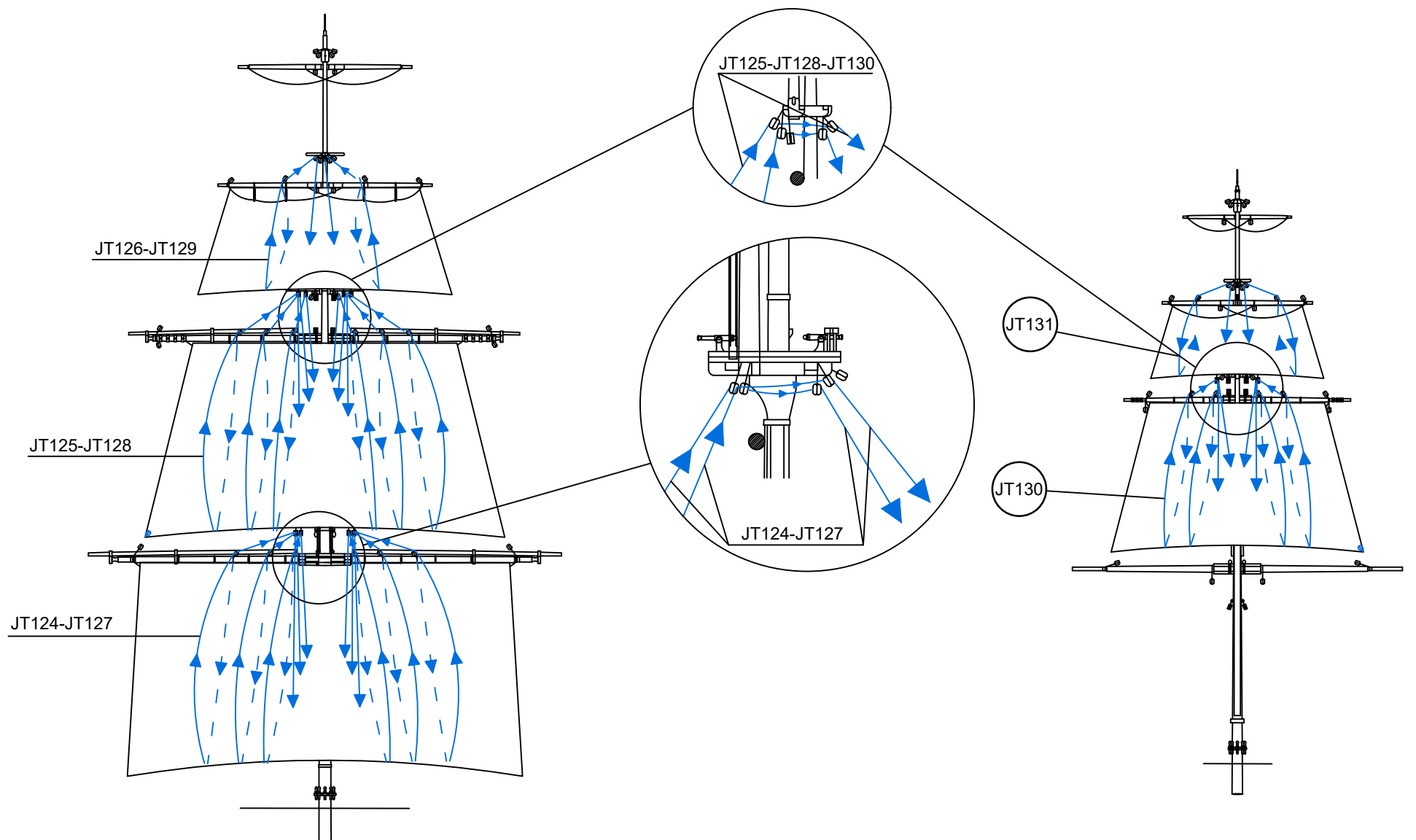

JT124	ø0,15x700	Hilo crudo / Raw thread / Fil brut / Rohes Baumwollfaden / Filo crudo	JT128	ø0,15x800	Hilo crudo / Raw thread / Fil brut / Rohes Baumwollfaden / Filo crudo
JT125	ø0,15x900	Hilo crudo / Raw thread / Fil brut / Rohes Baumwollfaden / Filo crudo	JT129	ø0,15x950	Hilo crudo / Raw thread / Fil brut / Rohes Baumwollfaden / Filo crudo
JT126	ø0,15x1100	Hilo crudo / Raw thread / Fil brut / Rohes Baumwollfaden / Filo crudo	JT130	ø0,15x1100	Hilo crudo / Raw thread / Fil brut / Rohes Baumwollfaden / Filo crudo
JT127	ø0,15x1200	Hilo crudo / Raw thread / Fil brut / Rohes Baumwollfaden / Filo crudo	JT131	ø0,15x1300	Hilo crudo / Raw thread / Fil brut / Rohes Baumwollfaden / Filo crudo

# La Belle Poule

OCCRE

M

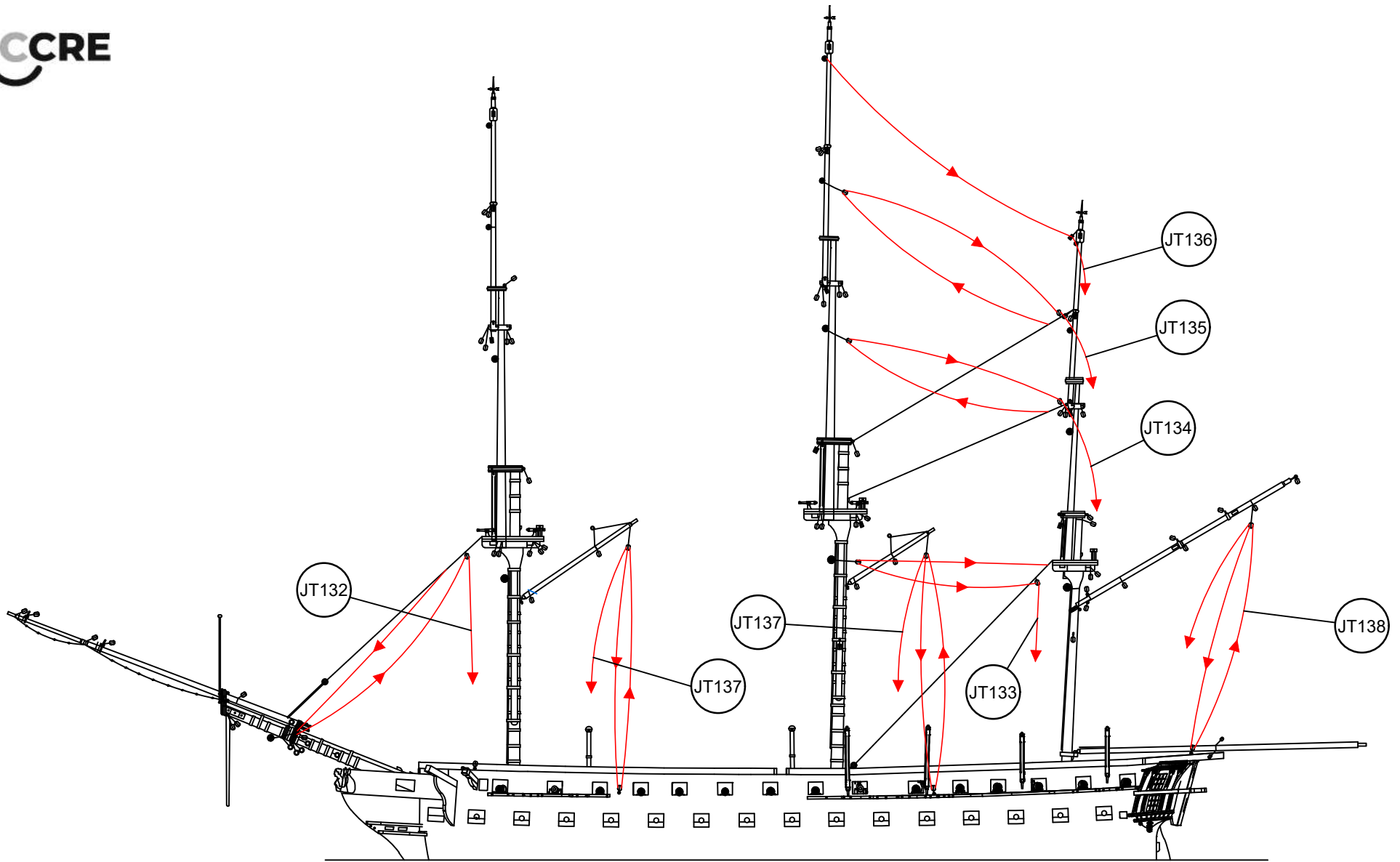

JT132	∅0,15x600	Hilo crudo / Raw thread / Fil brut / Rohes Baumwollfaden / Filo crudo	JT136	∅0,15x1300	Hilo crudo / Raw thread / Fil brut / Rohes Baumwollfaden / Filo crudo
JT133	∅0,15x900	Hilo crudo / Raw thread / Fil brut / Rohes Baumwollfaden / Filo crudo	JT137	∅0,15x500	Hilo crudo / Raw thread / Fil brut / Rohes Baumwollfaden / Filo crudo
JT134	∅0,15x1100	Hilo crudo / Raw thread / Fil brut / Rohes Baumwollfaden / Filo crudo	JT138	∅0,15x500	Hilo crudo / Raw thread / Fil brut / Rohes Baumwollfaden / Filo crudo
JT135	∅0,15x1200	Hilo crudo / Raw thread / Fil brut / Rohes Baumwollfaden / Filo crudo			

N

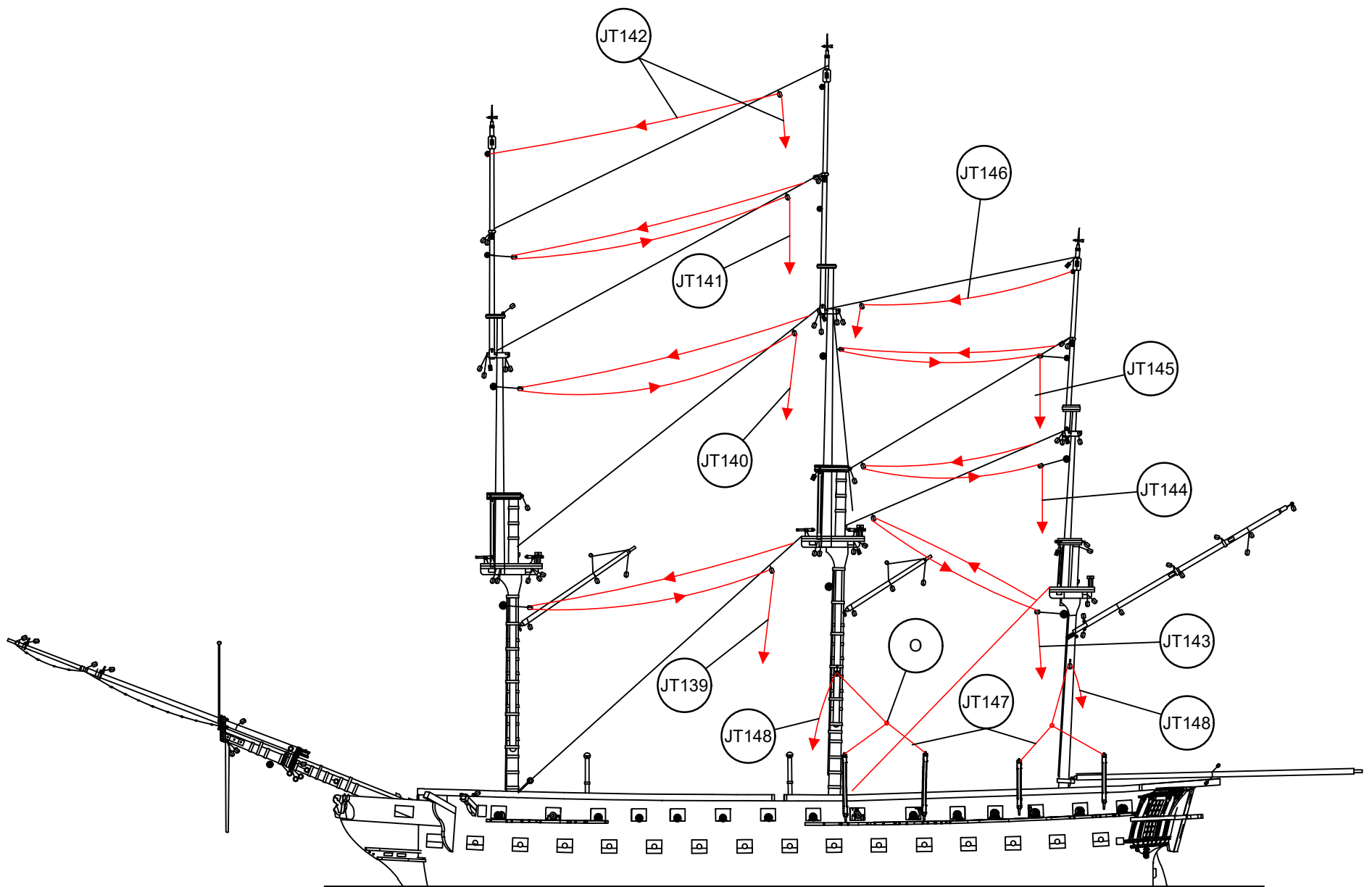

JT139	∅0,15x650	Hilo crudo / Raw thread / Fil brut / Rohes Baumwollfaden / Filo crudo	JT145	∅0,15x500	Hilo crudo / Raw thread / Fil brut / Rohes Baumwollfaden / Filo crudo
JT140	∅0,15x700	Hilo crudo / Raw thread / Fil brut / Rohes Baumwollfaden / Filo crudo	JT146	∅0,15x600	Hilo crudo / Raw thread / Fil brut / Rohes Baumwollfaden / Filo crudo
JT141	∅0,15x800	Hilo crudo / Raw thread / Fil brut / Rohes Baumwollfaden / Filo crudo	JT147	∅0,15x150	Hilo crudo / Raw thread / Fil brut / Rohes Baumwollfaden / Filo crudo
JT142	∅0,15x950	Hilo crudo / Raw thread / Fil brut / Rohes Baumwollfaden / Filo crudo	JT148	∅0,15x400	Hilo crudo / Raw thread / Fil brut / Rohes Baumwollfaden / Filo crudo
JT143	∅0,15x850	Hilo crudo / Raw thread / Fil brut / Rohes Baumwollfaden / Filo crudo	O	∅4	Latón / Brass / Latón / Messing / Ottone
JT144	∅0,15x650	Hilo crudo / Raw thread / Fil brut / Rohes Baumwollfaden / Filo crudo			

# La Belle Poule



Aparejo de velas / Sail rig / Gréement  
Segel takelage / Sartiamе da vela

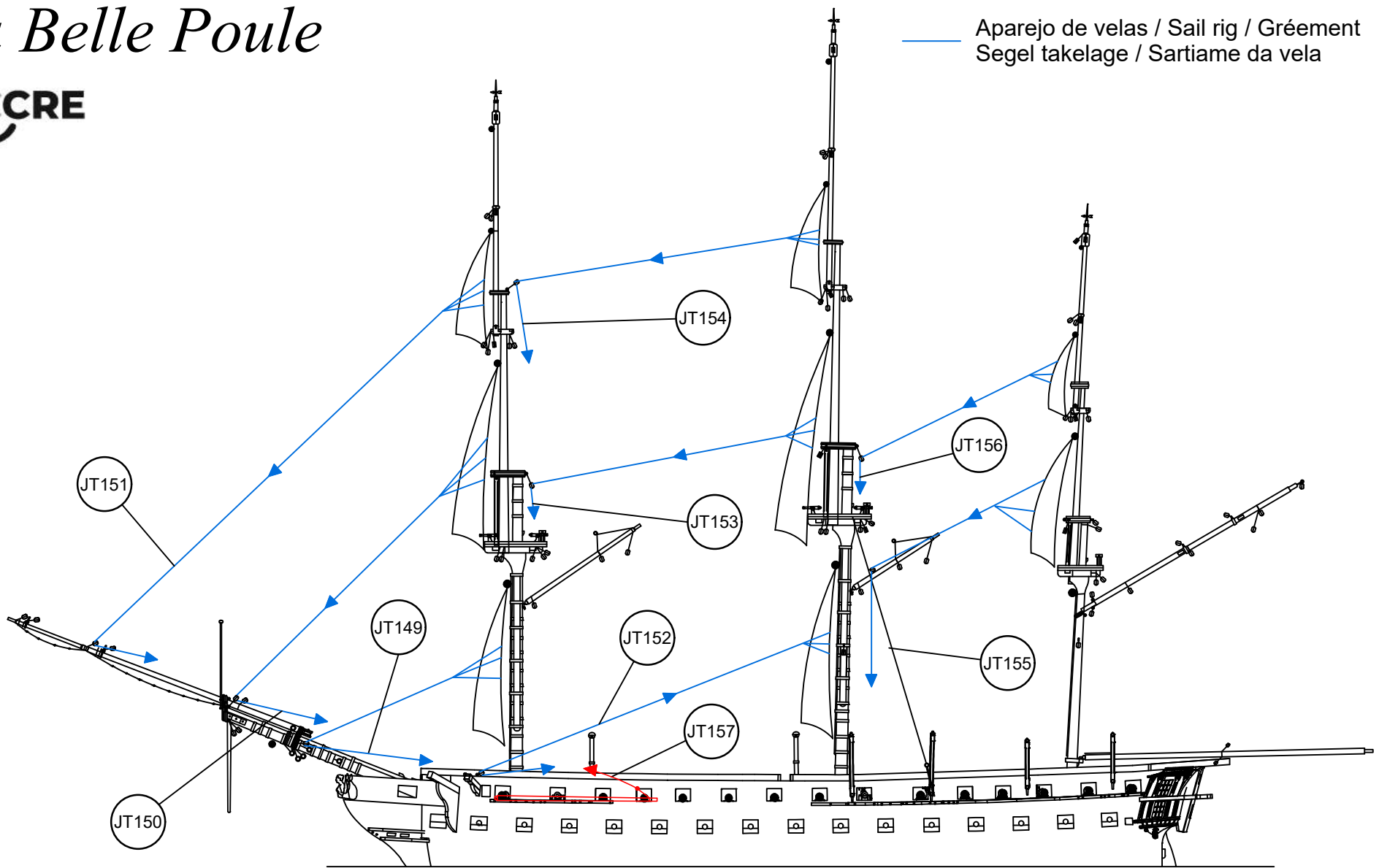
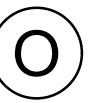

JT149	∅0,15x500	Hilo crudo / Raw thread / Fil brut / Rohes Baumwollfaden / Filo crudo	JT154	∅0,15x800	Hilo crudo / Raw thread / Fil brut / Rohes Baumwollfaden / Filo crudo
JT150	∅0,15x850	Hilo crudo / Raw thread / Fil brut / Rohes Baumwollfaden / Filo crudo	JT155	∅0,15x700	Hilo crudo / Raw thread / Fil brut / Rohes Baumwollfaden / Filo crudo
JT151	∅0,15x950	Hilo crudo / Raw thread / Fil brut / Rohes Baumwollfaden / Filo crudo	JT156	∅0,15x800	Hilo crudo / Raw thread / Fil brut / Rohes Baumwollfaden / Filo crudo
JT152	∅0,15x700	Hilo crudo / Raw thread / Fil brut / Rohes Baumwollfaden / Filo crudo	JT157	∅0,15x400	Hilo crudo / Raw thread / Fil brut / Rohes Baumwollfaden / Filo crudo
JT153	∅0,15x850	Hilo crudo / Raw thread / Fil brut / Rohes Baumwollfaden / Filo crudo			

