

ANTES DE COMENZAR, RECOPILE TODO EL MATERIAL DE APOYO PARA EL MONTAJE: Instrucciones de montaje / ilustraciones paso a paso / planos y plantillas impresos a escala.

PREPARACIÓN DEL MATERIAL: Para poder identificar correctamente las piezas precortadas, antes de extraerlas de las planchas de madera, marque en ellas la misma numeración que aparece en la hoja "IP" (identificación de piezas), incluida en las instrucciones. El grueso de los tableros puede variar medio milímetro de más o de menos.

INICIO DEL MONTAJE: Con la ayuda de un cúter y procurando no colocar los dedos en la línea de corte, desprenda las piezas de las planchas eliminando los pequeños nervios que las sujetan. Seguidamente lije con suavidad las piezas con papel de lija de grano fino, para eliminar el repelo de las mismas. El orden numérico del paso a paso indica el orden de elaboración y colocación de las piezas. Es importante comprobar el ajuste de las piezas antes de pegarlas definitivamente.

LISTONES Y VARILLAS: Los modelos incorporan varios tipos de listones y varillas para elaborar las diferentes piezas. La lista de piezas proporciona información sobre el tipo de material y medidas. En algunos casos es conveniente ajustar las medidas sobre el propio modelo, conforme avanzamos en el montaje. De esta manera se consigue un mejor ajuste.

PEGAMENTOS RECOMENDADOS: Cola blanca o de carpintero. Para las uniones de piezas de madera y de todas aquellas piezas que no ofrezcan resistencia.

Pegamento rápido. Para piezas que sean difíciles de sostener y que necesiten un secado casi instantáneo.

Cola de contacto o de zapatero. Para todas aquellas piezas que se forren con chapas finas de madera o metal. En todos los casos, lea siempre las instrucciones de uso del fabricante.

SERVICIO DE ATENCIÓN AL CLIENTE: Para cualquier duda o información sobre el montaje de nuestros productos, puede contactar con nuestro Servicio Técnico en la dirección:

www.occre.com. Le atenderemos con mucho gusto.

BEFORE STARTING, MAKE SURE YOU HAVE ALL THE SUPPORT MATERIAL FOR ASSEMBLING THE MODEL:

Assembly Instructions / Step by step pictures / Plans and templates printed to scale.

PREPARING THE MATERIAL: In order to correctly identify the precut parts, before removing them from the wooden sheets, mark on them the same numbers that appear on the "IP" (Part Identification) Sheet included with the instructions. The thickness of the boards can vary by half a millimeter more or less.

STARTING THE ASSEMBLY: Using a cutter, and making sure you do not put your fingers along the cutting line, remove the parts from the wooden sheets, eliminating the small sprues that hold them in place. In continuation smoothly sand down the parts, using fine grain sandpaper, to eliminate the pickup of the parts. The numerical order indicates the order in which the different parts must be made up and fitted.

STRIPS AND RODS: These models incorporate a variety of different types of strips and rods with which to make up the different parts of the kit. The list of parts proportions information on the type of material and measurements. In some cases it is advisable to adjust the measurements on the basis of the model itself, as assembly progresses. In this way you will achieve a better fit.

RECOMMENDED GLUES: White, or carpenter's glue: For joining pieces of wood together. Mainly used for gluing together the skeleton. Quick-drying glue. For parts that are difficult to hold in their final position and which need to set instantly. Recommended for fitting small parts. Contact or cobbler's glue. For gluing into place the parts that are covered with fine wood veneer to set instantly. In all cases, always follow the manufacturer's recommendations.

CUSTOMER ATTENTION SERVICE: In the case of whatsoever doubt or further information that you may require regarding the assembly of our products, please contact our Technical Service online at the address: www.occre.com. We will be delighted to attend to you.

AVANT DE COMMENCER, VÉRIFIEZ TOUT LE MATÉRIEL DE SOUTIEN POUR LE MONTAGE: Instructions de montage / Images étape par étape / Plans et modèles imprimés à l'échelle.

PRÉPARATION DU MATÉRIEL: Pour pouvoir identifier correctement les pièces prédécoupées, avant de les extraire des planches de bois, inscrivez sur elles la même numérotation qui apparaît sur la page « IP » (identification des pièces) comprise dans les instructions. L'épaisseur des planches peut varier d'un demi-millimètre plus ou moins.

DÉBUT DU MONTAGE: À l'aide d'un cutter, et en essayant de ne pas poser les doigts sur la ligne de découpe, séparez les pièces des planches en éliminant les petits nerfs qui les retiennent. Puis poncez doucement les pièces à l'aide d'un papier de verre à grain fin, pour éliminer le contrefil. L'ordre numérique des étapes photographiques et des plans indique l'ordre d'élaboration et d'installation des pièces.

LISTEAUX ET BAGUETTES: Les modèles intègrent plusieurs types de listeaux et de baguettes destinés à confectionner les différentes pièces. La liste des pièces indique le type de matériau et les dimensions des pièces. Il est parfois recommandé d'ajuster les mesures sur le modèle lui-même, au fur et à mesure que nous avançons dans le montage. De cette manière, on obtient un meilleur réglage.

COLLES RECOMMANDÉES: Colle blanche ou de menuisier: Pour les unions de pièces en bois et de toutes les pièces qui n'offrent pas de résistance. Colle à séchage rapide: Pour les pièces qui sont difficiles à maintenir dans leur position et qui requièrent un séchage pratiquement instantané. Colle de contact ou de cordonnier: Pour toutes les pièces qui sont recouvertes de fines plaques de bois ou de métal. Dans tous les cas, lisez toujours les instructions d'utilisation du fabricant.

SERVICE CLIENT: Pour toute question ou information concernant le montage de nos produits, vous pouvez contacter notre Service Technique à l'adresse suivante: www.occre.com.

Nous répondrons avec plaisir à vos questions.

PRIMA D'INIZIARE, RIUNIRE TUTTO IL MATERIALE D'APPOGGIO PER IL MONTAGGIO: Istruzioni di montaggio, immagini passo per passo, planimetrie e modelli stampati in scala.

PREPARAZIONE DEL MATERIALE: Per poter identificare in maniera corretta i pezzi che sono stati ritagliati, prima di estrarli dai blister di legno occorre segnarli con la stessa numerazione che è indicata nella pagina "IP" (Identificazione pezzi) che si trova nelle istruzioni. Lo spessore delle tavole può variare di mezzo millimetro in più o in meno.

INIZIO DEL MONTAGGIO: Con l'aiuto di un cutter, ed evitando di collocare le dita lungo la linea di taglio, separare i pezzi dai blister eliminando i piccoli nervi che li mantengono attaccati. In seguito, scartare con delicatezza i pezzi, utilizzando una carta vetrata a grana fine, onde eliminare le sbavature degli stessi. L'ordine numerico del passo per passo indica l'ordine d'elaborazione e di collocazione dei pezzi. È importante verificare che questi combacino bene, prima d'incollarli definitivamente.

ASTE E BACCHETTE: I modelli sono dotati di vari tipi di aste e bacchette per formare i diversi pezzi. L'elenco dei pezzi offre informazioni sul tipo di materiale e sulle misure. In alcuni casi è conveniente modificarne le misure quando sono sul modello, man mano che si avanza nel montaggio. In questo modo si potrà ottenere che combacino meglio.

COLLE RACCOMANDATE: Colla bianca o da falegname: Per unire tra loro i pezzi in legno e tutti quei pezzi che non presentino resistenza. Colla rapida: Per i pezzi difficili da sostenere e per i quali sia necessaria un'asciugatura quasi istantanea. Colla a contatto o da calzolaio: Per tutti quei pezzi che vengono rivestiti con fine lastre di legno o di metallo. In ogni caso, leggere sempre le istruzioni d'uso del produttore.

SERVIZIO ASSISTENZA CLIENTE: Per qualsiasi dubbio o informazione sul montaggio dei nostri prodotti, contattare il nostro Servizio Tecnico al seguente indirizzo: www.occre.com.

Seremo lieti di potervi aiutare.

BEVOR SIE MIT DEM ZUSAMMENBAU BEGINNEN, LEGEN SIE SICH BITTE ALLE HILFSMATERIALIEN FÜR DIE MONTAGE BEREIT:

Bastelanleitung / Maßstabsgerechte Skizzen und Schablonen / Skizzen und Vorlagen.

VORBEREITUNG DER MATERIALIEN: Damit die einzelnen Bauteile korrekt zugeordnet werden können, empfehlen wir, auf den Holzplättchen vor dem Herausnehmen mit einem Bleistift die Nummer auf dem Blatt IP (Identifikation Teile) zu markieren. Die Dicke der Bretter kann um mehr oder weniger einen halben Millimeter variieren.

BEGINN DES ZUSAMMENBAUS: Die Teile mit einem Schneidwerkzeug (Cutter) herauslösen und die kleinen Befestigungsenden entfernen. Dabei darauf achten, die Finger nicht zu verletzen. Danach die Teile vorsichtig mit feinem Schmirgelpapier säubern, um ausgefranste Ränder zu entfernen. Die Nummernfolge der Schritte auf Fotos und Skizzen gibt an, in welcher Reihenfolge die Teile zusammengebaut werden.

LEISTEN UND STÄBE: Die Modelle enthalten mehrere Arten von Leisten und Stäben, aus denen die einzelnen Teile des Bausatzes geformt werden. In einigen Fällen kann es angebracht sein, die Maße im Zuge des Zusammenbaus entsprechend dem Modell anzupassen. Auf diese Weise wird eine bessere Passform errichtet.

EMPFOHLENE KLEBSTOFFE: Weißleim (Tischlerleim): Zum Kleben von Strukturteilen und allen nachgiebigen Teilen. Sekundenkleber: Für schwer zu haltende Teile, die schnell verklebt werden müssen. Kontaktkleber (Schusterleim): Für alle Teile, die mit dünnen Holz- oder Metallstücken zum Beplanken oder Verkleiden beklebt werden. Bitte beachten Sie stets die Hinweise des Herstellers.

UNSER KUNDENDIENST: Bei Fragen zum Aufbau unserer Modelle steht Ihnen unser Kundendienst zur Verfügung. Sie erreichen uns online unter: www.occre.com.

Wir stehen Ihnen gern mit Rat und Tipps zur Verfügung.

A. Utilice un cúter para cortar los nervios que unen las piezas a las planchas, y así poder extraerlas sin dañarlas. Después, lije las piezas levemente con papel de lija de grano medio, para eliminar el posible repelo de la madera y los restos de los nervios de unión. Siguiendo el orden alfanumérico, inserte y pegue las piezas indicadas en las imágenes. Antes de encolar las cuadernas, A2 a A13, verifique que encajan correctamente en su posición haciendo “tope” en los encajes correspondientes de la falsa quilla, A1. Es importante que las cuadernas queden completamente perpendiculares a la falsa quilla para que posteriormente la cubierta encaje bien. Para esta operación utilice como adhesivo cola blanca, (Ref.19200). Mantenga las piezas inmovilizadas hasta que el adhesivo se seque. Inserte y pegue las piezas A13 hasta A23 como se indica en las imágenes. Comience a forrar ajustando la primera tira a la línea de lápiz. Utilice como adhesivo cola de contacto, (cola de zapatero). Con el mango de madera de una herramienta, frote fuertemente las chapas contra la cubierta para que se adhieran con firmeza. Coloque la cubierta bocabajo y corte los sobrantes de las chapas. Después, trace unas líneas y puntos para simular la tablazón. Lije la cubierta y aplíquele barniz satinado, (Ref.19419).

B-C. Lije y pinte de color gris, (Ref.19412), la parte superior de la cuaderna A8. Aplique cola blanca y pegue la cubierta A24. Para ayudar a inmovilizar la cubierta puede aplicar también pegamento rápido, (Ref.19201). Realice las mismas operaciones para forrar y colocar la cubierta B1. Asegúrese de que los salientes superiores de las cuadernas encajan en los rebajes de la cubierta. Ajuste y pegue también la cubierta B1. Coloque el casco boca abajo y comience a lijar empezado desde proa y avanzando hasta popa. Debe desbastar las aristas de las cuadernas, pero sin deformar su perfil original. El lijado del casco ha de quedar simétrico, es decir, que el lateral derecho ha de quedar igual que el izquierdo. El lijado debe realizarse en todo el casco y debe ser progresivo y suave. Compruebe con un listón B3, que el lijado es correcto. Para ello, debe deslizar el listón hacia arriba y hacia abajo presionándolo contra las cuadernas, para ver cómo se ajusta a la forma del casco. Elabore y pinte las piezas C1 y C2 de color gris, (Ref.19412) y péguelas como le muestra la imagen. Pinte la parte interna de las amuradas C3. Aplique cola y pegue las amuradas C3 y fíjelas mediante puntas A. Para esta operación puede utilizar un clavador, (Ref.19108), o un martillo.

D-E. Sumerja unos listones D1 en agua durante unos 15 minutos para que recuperen la flexibilidad. Inmediatamente después, utilice una plancha o algún objeto cilíndrico de diámetro aproximado de 10cm, para curvar los listones, si fuera necesario. Aplique cola y pegue el primer listón D1 ajustado a la parte superior de la cubierta y clávelo con puntas A. Deberá clavar una punta en cada punto donde el listón se cruza con una cuaderna. Después, corte el sobrante del listón a ras de la zona de proa. Continúe forrando el casco como le muestran las imágenes. Deberá aplicar cola a cada listón que añada al casco para que se fijen entre ellos y a las cuadernas. Para cubrir los huecos que los listones han dejado en el casco, elabore piezas E1 a medida. Aplique cola blanca y pegue las piezas para cerrar el casco. Una vez cerrado el forro del casco, proceda a lijarlo. Lije toda la superficie del forro y las cabezas de las puntas para dejarlas enrasadas con el forro. Debe quedar una superficie lisa y sin desniveles. Tanto la proa como la popa deben quedar como le indica la imagen.

F-G. Aplique cola de contacto, (cola de zapatero), a la zona del casco que le indican las imágenes. Aplique también cola de contacto a las tiras de forro F1. Cuando la cola no enganche al contacto con los dedos, será el momento de pegar las piezas. Corte a medida las tiras de forro dependiendo de la necesidad. Frote las tiras de forro con el mango de madera de alguna herramienta para que se adhieran con firmeza. Continúe con el forrado del casco desde la primera tira de forro hacia abajo y desde la falsa quilla hacia arriba. Elabore las piezas G1 a medida para cerrar los huecos que ha dejado el forro. Después lije el forro con papel de lija de grano fino para dejar su superficie fina y uniforme. Elabore las piezas G2 a G4, y píntelas de color gris, (Ref.19412). Realice un orificio de $\varnothing 6\text{mm}$ en la zona de popa, que atraviese hasta asomar por la cubierta. Este orificio es para más adelante colocar la pala del timón, observe la página M. Elabore y añada las piezas que le indican las imágenes.

H. Lije y pinte de color gris, (Ref.19412), las piezas H1 a H4. Después, pegue las piezas al casco. Llegada a esta fase de la construcción ya puede barnizar el casco. Después, líjelo con una esponja-lija de grano fino, (Ref.19155). Elimine el polvo resultante del pulido con un pincel seco. Si desea dejar el casco con el color de las maderas visto, aplique una segunda capa de barniz y déjelo secar. Si desea pintar el casco proceda de la siguiente manera: primero aplique imprimación, (Ref.19418), a todo el casco. Cuando se seque, lije el casco para dejarlo fino. Aíse la zona que le muestra la imagen con cinta de carrocer. Pinte la parte inferior del casco de color rojo, (Ref.19402). Después, siguiendo el mismo procedimiento, aíse y pinte el casco con los colores, negro, (Ref.19396), y gris, (Ref.19412).

i. Coloque en la parte de proa y de popa los refuerzos i1 a i5 sujetándolos con puntas A. Seguidamente coloque las piezas i6 en la parte de popa, una a cada lado del casco. A continuación, recorte a medida los listones i7 a i10 y péguelos a ambos lados del casco como le muestran las imágenes. Vaya realizando los orificios necesarios para colocar los cáncamos B, y demás piezas que le indican las imágenes. Decore la pala del timón y añada las piezas indicadas en las imágenes. Inserte y fije la pala del timón mediante sus ejes.

J-K-L. Para elaborar las piezas J1 a J3 humedezca primero los listones. Después, córvelos levemente utilizando una plancha caliente. Ajuste y pegue las piezas que las imágenes le van indicando. Decore las piezas con los colores indicados en las imágenes, tinte sapeli, (Ref.19420), color negro, (Ref.19396), blanco, (Ref.19395), rojo, (Ref.19402) y gris, (Ref.19412). Para colocar algunas de las piezas, deberá realizar orificios en la cubierta. Vaya añadiendo las piezas en el barco utilizando como referencia, la plantilla PL-01.

M. De forma a las piezas M1 utilizando unos alicates. Corte a medida la chimenea la pieza M2. Añada las piezas M2 y B a la chimenea y decórela con los colores gris, (Ref.19412) y negro, (Ref.19396). Construya la caseta y píntela de color gris, (Ref.19412). Pinte las piezas M10 de color blanco, (Ref.19395) y negro, (Ref.19396). Construya el conjunto del timón y decórela con los colores indicados en las imágenes. Construya el enjaretado con las piezas M19. Córtelo a medida y enmárquelo con las piezas M20 a M22. Decore y coloque todas las piezas de cubierta que le indican las imágenes.

N-O-P. Construya las piezas que le indican las imágenes. Para unir las cadenas deberá abrir sus eslabones con unos alicates y unirlos mediante las anillas y cáncamos B, indicados en las imágenes. Construya y decore la pasarela. Después, añádale los pilarotes y pase los hilos para construir sus barandillas. Deberá ir ajustando a medida elaborar las barandillas con porciones de hilo de latón. Continúe elaborando y colocando las piezas que le indican las fotos. Utilice la plantilla PL-01 de referencia para su colocación.

Q-R. Pinte las piezas Q1 y Q2 de color negro, (Ref.19396), y después, destaque sus relieves con la técnica de pincel seco, con color blanco, (Ref.19395). Añada los cuadernales E a los conjuntos de las anclas mediante hilo C, y las anillas Q3. Para elaborar los cadenotes, primero extraiga las piezas Q6 de la plancha que las agrupa y con unos alicates, curve su extremo más estrecho. Inserte una anilla Q3 y una vigota G. Dé forma al cadenote y fíjelo al casco mediante puntas A. En la plantilla PL-01 podrá ver la posición aproximada de los cadenotes. Para elaborar las barandillas del casco, inserte y fije los pilarotes en la cubierta. Observe que hay varios tipos de pilarotes. Después, inserte las porciones de hilo por sus orificios. Aplique pegamento y corte los sobrantes de hilo. Decore las piezas R1 a R4 de color gris, (Ref.19412). Pegue las piezas R1 a R4 sobre los pilarotes. Pinte los rótulos R5 del mismo color gris y péguelos en la zona del casco que muestran las imágenes. Siga las indicaciones de las imágenes siguientes para construir las cuatro barcas. Es aconsejable que identifique las piezas de cada barca y las extraiga de la plancha que las agrupa por separado para no mezclarlas. Una vez contruidos los esqueletos, líjelos y fórrelos con las piezas R20. Enmasille las barcas para dejarlas finas y después pinte y añada las piezas que le indican las imágenes.

S. Elabore las piezas S1 a S4. Construya los conjuntos de las luces de situación y decórelas con los colores indicados en las imágenes. Inserte y pegue una cabilla J en cada orificio que le indican las imágenes. Corte las telas S6 utilizando la plantilla PL-01. Péguela a las barcas y píntelas de color verde, (Ref.19407). Utilice la plantilla para elaborar el acollador de las barcas y colocarlas en el barco. Construya la peana y tíñala con tinte de color sapeli, (Ref.19420). Pinte la pieza S12 de color negro, (Ref.19396) y destaque sus relieves de color gris, (Ref.19412).

ARBOLADURA

Para elaborar los mástiles, el primer paso a seguir será cortar las varillas según las medidas que indica la lista de piezas, o bien tomarlas directamente de los planos que están impresos a escala 1/1.

Todos los mástiles y vergas tienen cierta conicidad que se deberá realizar.

Para realizar la conicidad a los mástiles, lije las varillas, (con un lijador), aumentando el desgaste de ésta a medida que se acerca al extremo donde se quiere disminuir el diámetro.

Haga rodar la varilla para que el desgaste sea igual por todo el contorno hasta conseguir llegar al diámetro que indica el plano.

Para elaborar la conicidad de las vergas, realice las mismas operaciones, pero esta vez a ambos extremos de la varilla.

Deberá teñir o pintar las varillas en función del modelo que esté construyendo.

Para realizar correctamente los mástiles de este modelo se deberá tener en cuenta:

- Los planos
- Las fotos de detalle de los mástiles
- Las medidas y descripción de materiales de la lista de piezas
- Las hojas “IP” de identificación de piezas
- La plantilla PL-01

Los mástiles se deberán barnizar y algunas de las piezas que los componen se deberán pintar. Véanse las fotos generales de detalle de los mástiles.

Una vez montados y barnizados, deberán colocarles los aparejos, (estrobos, cuadernales, cáncamos, motones, etc.), y fijarlos al barco.

Los mástiles se deben introducir hasta hacer tope en los encajes de la falsa quilla.

JARCIA

Para elaborar la jarcia de este barco, siga el orden alfabético de las figuras impresas de los planos, que indican el orden de colocación: de hilos, vigotas, motones, velas, etc, destacados en color rojo. La lista de piezas le orientará sobre el tipo de materiales y medidas a utilizar.

Para simular el envejecido de las velas, se les puede dar un baño con infusión de té, sin hacerlas hervir, y dejarlas secar bien arrugadas.

Se colocaran sin planchar para que tengan cuerpo.

A. Use a cutter to cut the ribs that join the parts to the sheet, so you can remove them without damaging them. Next, lightly sand the pieces with medium-grain sandpaper to remove any burs and remaining wood. Following the alphanumeric order insert and glue the parts as shown in the illustrations. Before gluing the frames, check that they fit correctly in their position by fitting them into the corresponding sockets of the false keel. It is important that the frames are completely perpendicular to the false keel so that the deck fits well afterwards. Use white glue for this operation, (Ref.19200). Keep parts immobilized until adhesive dries. Insert and glue parts A13 to A23 as shown in the pictures. Start lining by fitting the first strip to the pencil line. Use contact glue, (shoemaker's glue). Using the wooden handle of a tool, rub the strips firmly against the cover so that they adhere firmly. Place the deck upside down and cut the leftovers from the sheets. Then draw a few lines and dots to simulate the planking. Sand the cover and apply satin varnish, (Ref.19419).

B-C. Sand and paint grey, (Ref.19412), the top of the A8 frame. Apply white glue and glue deck A24. To help immobilize the deck you can also apply instant glue, (Ref.19201). Perform the same operations to line and fit deck B1. Make sure that the upper projections of the frames fit into the deck recesses. Adjust and glue the deck B1 as well. Place the hull upside down and start sanding starting from bow to stern. You must roughen the edges of the frames, but without spoiling their original shape. The hull must be sanded symmetrically; that is, the right side must be identical to the left. You must sand the entire hull and progressively and smoothly. Use a strip B3 to check that the sanding is correct. To do this, you must slide the slat up and down by pressing it against the frames, to see how it fits the shape of the hull. Assemble and paint the grey parts C1 and C2, (Ref.19412) and glue them as shown in the picture. Paint the inside of the C3 bulwarks. Apply adhesive and glue the C3 bulwarks and fix them using A pins. You can use a nailing tool, (Ref.19108), or a hammer.

D-E. Soak some D1 slats in water for about 15 minutes until they are flexible. Immediately afterwards, use an iron or a cylindrical object about 10cm in diameter, to bend the slats, if necessary. Apply glue and stick the first slat D1 fitted to the top of the deck and fix it using pins A. You must insert a pin at each point where the plank intersects with a frame. Then cut the excess flush with the bow area. Continue lining the hull as shown in the pictures. You must apply glue to each slat that you fit to the hull so that they are firmly fastened to each other and to the frames. To cover the gaps that the slats have left in the hull, make custom parts E1. Apply white glue and glue the parts to close the hull. Once the hull lining is complete, sand it. Sand the entire surface of the lining and pin heads so they are flush with the surface. You must achieve a smooth, even surface. The bow and stern must be as shown in the illustration.

F-G. Apply contact glue, (shoemaker's glue), to the area of the hull shown in the illustrations. Also apply contact glue to the F1 lining strips. When the glue is not sticky to the touch, it is time to glue the pieces. Cut to size the lining strips as needed. Rub the lining strips with the wooden handle of a tool so that they adhere firmly. Continue lining the hull from the first plank downwards and from the false keel upwards. Shape the G1 parts so they fill the gaps left in the lining. Then sand it with fine-grained sandpaper until the surface is fine and even. Make parts G2 to G4, and paint them grey, (Ref.19412). Make a $\varnothing 6$ mm hole in the aft area, which crosses until it appears on the deck. The rudder stock will be fitted in this hole; refer to page M. Prepare and add the pieces shown in the illustrations.

H. Sand and paint grey, (Ref.19412), parts H1 to H4. Then, glue the parts to the hull. At this stage of construction you can varnish the hull. Then, sand it with a fine-grained sanding sponge, (Ref.19155). Remove dust resulting from polishing with a dry brush. If you want to leave the hull with the natural colour of the woods, apply a second layer of varnish and let it dry. If you want to paint the hull, first apply primer, (Ref.19418), to the entire hull. When dry, sand the hull till it is smooth. Mask the area shown in the illustration with masking tape. Paint the bottom of the hull red, (Ref.19402). Then, following the same procedure, mask and paint the hull black, (Ref.19396), and grey, (Ref.19412).

i. Place the reinforcements i1 to i5 on the fore and aft part, fastening them with pins A. Then place the pieces i6 on the aft part, one on each side of the hull. Next, cut out slats i7 to i10 and glue them on both sides of the hull as shown in the pictures. Make the necessary holes to place the B eyebolts, and other parts shown in the illustrations. Decorate the rudder blade and add the parts shown in the pictures. Insert and fix the rudder blade by its stock.

J-K-L. To make parts J1 to J3 wet the strips first. Then, curl them slightly using a hot iron. Adjust and glue the parts as shown in the pictures. Decorate the pieces using the colours indicated in the illustrations, sapele dye, (Ref.19420), black, (Ref.19396), white, (Ref.19395), red, (Ref.19402) and grey, (Ref.19412). To fit some of the parts, you will need to make holes in the deck. Add the pieces on the boat using template PL-01 as a reference.

M. Shape parts M1 using pliers. Cut the chimney piece M2 to size. Add parts M2 and B to the chimney and paint it grey, (Ref.19412) and black, (Ref.19396). Build the deckhouse and paint it grey, (Ref.19412). Paint parts M10 white, (Ref.19395) and black, (Ref.19396). Build the rudder assembly and decorate it using the colours shown in the pictures. Construct the grating using parts M19. Cut to size and frame it, using parts M20 to M22. Decorate and fit all the deck fittings shown in the pictures.

N-O-P. Build the parts shown in the pictures. To join the chains, you must open their links with pliers and join them using the rings and eyebolts B, as shown in the images. Build and decorate the walkway. Then, add the stanchions and thread the cord to make the railings. Make the rails using brass wire. Continue to make and fit the pieces indicated in the photos. Use template PL-01 as a reference.

Q-R. Paint pieces Q1 and Q2 black, (Ref.19396), and then highlight their reliefs with the dry brush technique, in white, (Ref.19395). Add blocks E to the anchor assemblies using wire C, and rings Q3. To make the chains, first remove parts Q6 from the sheet that holds them and bend their narrower end using pliers. Insert a Q3 ring and a deadeye (G). Shape the chainplate and fix it to the hull using pins (A). On template PL-01 you can see the approximate position of the chainplates. To make the hull handrails, insert and fix the stanchions into the deck. Notice that there are several types of stanchions. Then insert the thread through their holes. Apply glue and cut the leftover thread. Paint parts R1 to R4 grey, (Ref.19412). Glue parts R1 to R4 on the stanchions. Paint the nameplates R5 the same grey colour and glue them in the area of the hull shown in the images. Follow the directions in the pictures below to build the four boats. It is advisable to identify the pieces of each boat and extract them from the sheet that groups them one at a time so as not to mix them. Once the frames are built, sand them and line them with parts R20. Apply filler to the boats to make them even and then paint and add the pieces shown by the pictures.

S. Prepare parts S1 to S4. Construct the sets of steaming lights and decorate them with the colours indicated in the pictures. Insert and paste a belaying pin (J) into each hole, as shown in the pictures. Cut cloth S6 using template PL-01. Glue it to the boats and paint them green, (Ref.19407). Use the template to make the ropes for the boats and rig them. Construct the pedestal and stain it with sapele dye, (Ref.19420). Paint part S12 black, (Ref.19396) and highlight its grey reliefs, (Ref.19412).

MASTS AND SPARS

To make the masts, the first step will be to cut the dowels to the measurements in the parts list, or take them directly from the drawings that are printed at 1/1 scale.

All masts and spars have a certain taper that must be made.

To taper the masts, sand the dowels (with a sander), removing more wood as you reach the end where you want to decrease the diameter.

Roll the dowel so that the wear is equal along its length until you reach the diameter shown on the drawing.

To taper the spars, perform the same operations, but this time at both ends.

You will need to dye or paint the rods depending on the model you are building.

To correctly make the masts of this model, the following must be taken into account:

- The plans
- The detailed photos of the masts
- The measurements and description of materials of the parts list
- Part identification "IP" sheets
- Template PL-01

The masts must be varnished and some of their pieces must be painted. See general detail photos of the masts.

Once assembled and varnished, you must rig them, (snotters, deadeyes, eyebolts, blocks, etc.), and attach them to the boat.

The masts must be inserted until they abut the sockets of the false keel.

RIGGING

To prepare the rigging, follow the alphabetical order of the printed illustrations on the plans, which indicate the order of placement: of cords, spars, blocks, sails, etc., highlighted in red. The parts list will guide you on the type of materials and measurements to be used.

To simulate the ageing of the sails, soak them in tea, and left to dry while wrinkled. Do not boil them.

Bend them on without ironing so that they have body.

A. Utilisez un cutter pour découper les nerfs qui unissent les pièces aux planches, afin de les extraire sans les endommager. Puis, poncez légèrement les pièces avec du papier de verre à grain moyen, pour éliminer les résidus éventuels de bois et les restes de nerfs d'union. Suivant l'ordre alphanumérique, insérez et collez les pièces indiquées sur les images. Avant de coller les couples A2 et A13, vérifiez qu'ils s'ajustent correctement à leur place et font office de taquet dans les emboîtements correspondants de la fausse quille A1. Il est important que les couples restent totalement perpendiculaires à la fausse quille afin que le pont vienne s'emboîter correctement par la suite. Pour cette opération, utilisez comme adhésif de la colle blanche (Réf. 19200). Maintenez les pièces immobilisées jusqu'à ce que la colle sèche. Insérez et collez les pièces de A13 à A23 comme indiqué sur les images. Commencez à border en faisant suivre la première rangée sur la ligne tracée au crayon. Utilisez la colle de contact (colle de cordonnier). À l'aide du manche en bois d'un outil, frottez fortement la planche contre le pont pour qu'elle y adhère fermement. Renversez le pont et découpez les excédents de plaques. Puis tracez des lignes et des points pour simuler le bordage. Poncez le pont et appliquez le vernis satiné (Réf. 19419).

B-C. Poncez et peignez la partie supérieure du couple A8 de couleur grise (Réf. 19412). Appliquez la colle blanche et collez le pont A24. Pour contribuer à immobiliser le pont, vous pouvez appliquer également de la colle rapide (Réf. 19201). Réalisez ces mêmes opérations pour border et positionner le pont B1. Assurez-vous que les saillies supérieures des couples s'emboîtent dans les rainures du pont. Adaptez et collez également le pont B1. Placez la coque à l'envers et commencez à poncer en commençant par la proue et en avançant vers la poupe. Il faudra dégrossir les arêtes des couples, mais sans en altérer la forme originale. Le ponçage de la coque doit être réalisé de manière symétrique, c'est à dire que le côté droit doit être identique au gauche. Le ponçage doit être réalisé sur toute la coque, et doit être progressif et doux. Vérifiez à l'aide d'un listeau B3 que le ponçage est correct. Pour cela, faire glisser le listeau vers le haut puis vers le bas en exerçant une pression contre les couples pour voir comment il s'adapte à la forme de la coque. Élaborez et peignez les pièces C1 et C2 de couleur grise (Réf. 19412) et collez-les comme le montre l'image. Peignez la partie intérieure des pavois C3. Appliquez de la colle et collez les pavois C3 et fixez-les à l'aide des pointes A. Pour cette opération, vous pouvez utiliser un marteau de cloueur (Réf. 19108) ou un marteau simple.

D-E. Plongez quelques lattes D1 dans de l'eau pendant 15 minutes environ pour qu'elles reprennent un peu de souplesse. Puis immédiatement après, utilisez une planche ou un objet cylindrique d'un diamètre d'environ 10 cm pour courber les lattes si nécessaire. Appliquez la colle et collez la première latte D1 en l'adaptant à la partie supérieure du pont, puis clouez à l'aide de pointes A. Vous devrez clouer une pointe sur chaque point de la latte croisant un couple. Ensuite, découpez l'excédent de la latte au ras de la zone de la proue. Continuez à border la coque comme le montrent les images. Vous devrez appliquer de la colle sur chaque latte que vous ajouterez sur la coque, pour qu'elles soient bien fixées sur la coque et les couples. Pour recouvrir les zones creuses que les lattes ont laissées sur la coque, confectionnez des pièces E1 sur mesure. Appliquez de la colle blanche et collez les pièces pour refermer la coque. Une fois le bordage de la coque terminé, passez au ponçage. Poncez toute la surface du bordé, et la tête des pointes pour les mettre au ras du bordé. La surface doit rester lisse et sans irrégularités. La proue comme la poupe doivent apparaître comme le montre l'image.

F-G. Appliquez de la colle de contact (colle de cordonnier) sur la zone de la coque indiquée sur les images. Appliquez également de la colle de contact sur les lattes du bordé F1. C'est lorsque la colle ne s'accrochera plus aux doigts qu'il faudra se mettre à coller les pièces. Découpez sur mesure les lattes du bordé en fonction des besoins. Frottez les lattes du bordé avec le manche en bois d'un outil pour faire fermement adhérer. Poursuivez le bordage de la coque de la première latte du bordé vers le bas, puis de la fausse quille vers le haut. Confectionnez les pièces G1 sur mesure pour remplir les creux qu'a laissé le bordage. Puis poncez le bordé avec du papier de verre à grain fin, pour laisser sa surface fine et uniforme. Confectionnez les pièces G2 à G4, et peignez-les de couleur grise (Réf. 19412). Réalisez un orifice de ø 6 mm sur la zone de la poupe, traversant jusqu'au pont. Cet orifice servira plus tard à placer le safran du gouvernail, observez la page M. Élaborez et décorez les pièces indiquées sur les images.

H. Poncez et peignez de couleur grise (Réf. 19412) les pièces H1 et H4. Puis, collez les pièces sur la coque. Parvenu à cette phase de la construction, vous pouvez vernir la coque. Puis, poncez-la avec une éponge de ponçage à grain fin (Réf. 19155). Éliminez la poussière après ponçage à l'aide d'un pinceau sec. Si vous souhaitez laisser visible la couleur bois de la coque, appliquez une deuxième couche de vernis et laissez sécher. Si vous souhaitez peindre la coque, procédez de la manière suivante : appliquez d'abord l'apprêt (Réf. 19418) sur toute la coque. Une fois sèche, poncez la coque pour la lisser. Isolez la zone que vous montre l'image avec du ruban de masquage. Peignez la sous-marine de la coque avec de la peinture de couleur rouge (Réf. 19402). Puis selon la même procédure, isolez et peignez la coque de couleur noire (Réf. 19396) et grise (Réf. 19412).

i. Placez dans la partie de la proue et de la poupe les renforts i1 à i5 en les fixant à l'aide de pointes A. Ensuite, placez les pièces i6 sur la partie de la poupe, une de part et d'autre de la coque. Puis, découpez sur mesure les lattes i7 à i10 et collez-les des deux côtés de la coque comme le montrent les images. Réalisez les orifices nécessaires aux anneaux de levage B, et autres pièces indiquées sur les images. Décorez le safran du gouvernail et ajoutez les pièces indiquées sur les images. Insérez et fixez le safran du gouvernail au moyen de ses axes.

J-K-L. Pour confectionner les pièces J1 à J3, humidifiez d'abord les lattes. Puis, courbez-les légèrement en utilisant une planche chaude. Ajustez et collez les pièces qu'indiquent les images. Décorez les pièces avec les couleurs indiquées sur les images, teinte sapeli (Réf. 19420), couleur noire (Réf. 19396), blanche (Réf. 19395), rouge (Réf. 19402) et gris (Réf. 19412). Pour placer quelques pièces, vous devrez réaliser des orifices sur le pont. Ajoutez des pièces sur le bateau en utilisant comme référence la base PL-01.

M. Formez les pièces M1 à l'aide de tenailles. Découpez sur mesure la cheminée, pièce M2. Ajoutez les pièces M2 et B à la cheminée et décorez-la avec les couleurs grise (Réf. 19412) et noire (Réf. 19396). Construisez la cabine de pilotage et peignez-la de couleur grise (Réf. 19412). Peignez les pièces M10 de couleur blanche (Réf. 19395) et noire (Réf. 19396). Confectionnez l'ensemble du gouvernail et décorez-le selon les couleurs indiquées sur les images. Construisez le plancher de fond à l'aide des pièces M19. Découpez sur mesure et encadrez-le avec les pièces M20 à M22. Décorez et placez toutes les pièces du pont que vous indiquent les images.

N-O-P. Construisez et décorez les pièces indiquées sur les images. Pour assembler les chaînes, il vous faudra ouvrir les chaînons à l'aide de tenailles et les assembler avec des anneaux et des anneaux de levage B, comme indiqué sur les images. Construisez et décorez la passerelle. Puis, ajoutez les barreaux et passez les fils pour confectionner les mains-courantes. Vous devez ajuster au fur et à mesure que vous élaborez les mains-courantes avec des portions de fil en laiton. Continuez à confectionner et à placer les pièces que vous indiquent les photos. Utilisez la base PL-01 en référence pour les placer.

Q-R. Peignez les pièces Q1 et Q2 de couleur noire (Réf. 19396), puis, marquez ses reliefs moyennant la technique du pinceau sec, de couleur blanche (Réf. 19395). Ajoutez les couples E aux ensembles des ancras à l'aide d'un fil C et les anneaux Q3. Pour confectionner les cadènes, extrayez d'abord les pièces Q6 de la planche qui les unit, et à l'aide de tenailles, courbez leur extrémité plus étroite. Insérez un anneau Q3 et un cap de mouton G. Formez la cadène, et fixez-la à la coque à l'aide de pointes A. Sur la base PL-01, vous pourrez voir la position approximative des cadènes. Pour confectionner les mains-courantes de la coque, insérez et fixez les barreaux sur le pont. Attention, il y a plusieurs sortes de barreaux. Puis, insérez les portions de fil dans leurs orifices. Appliquez de la colle et découpez les excédents de fil. Décorez les pièces R1 à R4 de couleur grise (Réf. 19412). Collez les pièces R1 à R4 sur les barreaux. Peignez les panneaux R5 de la même couleur grise, et collez-les sur la zone de la coque que montrent les images. Suivez les instructions des images suivantes pour construire les quatre barques. Il est conseillé d'identifier les pièces de chaque canot et de les extraire de la planche qui les regroupe et les séparer pour ne pas les mélanger. Une fois les armatures construites, poncez-les et bordez-les à l'aide des pièces R20. Appliquez du mastic sur les canots pour les lisser, puis peignez et ajoutez les pièces comme indiqué sur les images.

S. Confectionnez les pièces S1 à S4. Confectionnez les ensembles de lumières de situation et décorez-les avec les couleurs indiquées sur les images. Insérez et collez un cabillot J sur chaque orifice comme indiqué sur les images. Découpez les toiles S6 en utilisant la base PL-01. Collez-les aux canots et peignez-les de couleur verte (Réf. 19407). Utilisez la base pour élaborer la longe des canots et les placer dans le bateau. Confectionnez le socle et teintez-le avec la teinte sapeli (Réf. 19420). Peignez la pièce S12 de couleur noire (Réf. 19396) et marquez ses reliefs de couleur grise (Réf. 19412).

MÂTURE

Pour confectionner les mâts, la première étape à suivre sera de couper les baguettes aux mesures indiquées par la liste de pièces, ou de les prendre directement sur les plans qui sont imprimés à l'échelle 1/1.

Tous les mâts et vergues présentent une certaine conicité qu'il faudra former.

Pour réaliser la conicité des mâts, poncer la baguette (à l'aide d'une ponceuse), en renforçant l'usure de celle-ci à mesure que l'on se rapproche de l'extrémité où l'on souhaite réduire le diamètre.

Tournez la baguette pour égaliser l'usure sur tout le contour jusqu'à parvenir au diamètre indiqué sur le plan.

Pour élaborer la conicité des vergues, renouveler les mêmes opérations mais cette fois-ci aux deux extrémités de la baguette.

Vous devrez teindre ou peindre les baguettes en fonction du modèle que vous construisez.

Pour réaliser correctement les mâts de ce modèle, il faudra prendre en considération :

- Les plans
- Les photos de détail des mâts
- Les dimensions et la description des matériels de la liste de pièces.
- Les pages "IP" d'identification des pièces.
- Le modèle PL-01

Les mâts devront être vernis et certaines des pièces qui les composent devront être peintes. Les photos générales de détail des mâts.

Une fois montés et vernis, les gréements devront être placés (estropes, couples, anneaux de levage, poulies, etc.), et les fixés au bateau.

Les mâts doivent être introduits jusqu'à ce qu'ils butent pour s'emboîter dans la fausse quille.

GRÉEMENT

Pour élaborer le gréement de ce bateau, suivez l'ordre alphabétique des figures imprimées sur les plans, qui indiquent l'ordre de placement. des fils, des caps de moutons, voiles, etc. signalés en couleur rouge. La liste des pièces vous indiquera le type de matériels et de mesures à employer.

Pour simuler le vieillissement des voiles, on peut les tremper dans une infusion de thé, sans les faire bouillir, et les laisser sécher bien froissées.

Elles seront posées non repassées pour leur donner du corps.

A. Con un taglierino tagliare le nervature che uniscono i pezzi al blister in modo da poterli rimuovere senza danneggiarli. Successivamente, carteggiare leggermente i pezzi con carta vetrata a grana media per eliminare eventuali venature del legno e i resti delle nervature di collegamento. In ordine alfanumerico, inserire e incollare le parti mostrate nelle immagini. Prima di incollare le coste, da A2 ad A13, verificare che si inseriscano correttamente in posizione, incastrandole nei corrispondenti alloggiamenti della falsa chiglia, A1. È importante che le coste siano completamente perpendicolari alla falsa chiglia in modo che il ponte si inserisca correttamente. Per questa operazione utilizzare come collante la colla bianca (cod. 19200). Tenere le parti immobilizzate fino all'asciugatura della colla. Inserire e incollare i pezzi da A13 ad A23 come mostrato nelle immagini. Iniziare il rivestimento regolando la prima striscia sulla linea della matita. Utilizzare la colla a contatto (colla per ciabattini) come collante. Con il manico di legno di un attrezzo, strofinare con forza le lastre contro il rivestimento in modo che aderiscano saldamente. Posizionare il ponte a faccia in giù e tagliare le lastre in eccesso. Disegnare quindi linee e punti per simulare l'intavolatura. Carteggiare il ponte e applicare la vernice satinata (rif. 19419).

B-C. Carteggiare e verniciare la parte superiore della costa A8 in grigio (rif. 19412). Applicare la colla bianca e incollare il ponte A24. Per immobilizzare la copertura si può applicare anche la colla rapida (rif. 19201). Procedere allo stesso modo per il rivestimento e il montaggio del ponte B1. Assicurarsi che le sporgenze superiori dei coste si inseriscano nelle cavità della copertura. Montare e incollare anche il ponte B1. Capovolgere lo scafo e iniziare a carteggiare partendo da prua e procedendo verso poppa. I bordi delle coste devono essere irruviditi, ma senza deformare il loro profilo originale. Lo scafo deve essere carteggiato in modo simmetrico, cioè il lato destro deve essere uguale a quello sinistro. La carteggiatura deve essere eseguita su tutto lo scafo e deve essere progressiva e liscia. Controllare con un'asta B3 che la levigatura sia corretta. A tale scopo, far scorrere l'asta verso l'alto e verso il basso e premerla contro le coste per vedere come si conforma alla forma dello scafo. Realizzare e verniciare le parti C1 e C2 in grigio (rif. 19412) e incollarle come mostrato in figura. Dipingere l'interno delle paratie C3. Applicare la colla e incollare i parapetti C3 e fissarli con i pezzi A. Per questa operazione si può usare una chiodatrice (rif. 19108) o un martello.

D-E. Immergere alcuni aste D1 in acqua per circa 15 minuti per ripristinare la loro flessibilità. Subito dopo, utilizzare un ferro da stiro o un oggetto cilindrico con un diametro di circa 10 cm per piegare i aste, se necessario. Applicare la colla e incollare la prima asta D1 ben salda alla parte superiore del ponte e inchiodarla con i chiodini A. Sarà necessario inchiodare un chiodino in ogni punto in cui l'asta interseca una costa. Tagliare quindi l'asta in eccesso a filo della zona di prua. Continuare a rivestire lo scafo come mostrato nelle immagini. È necessario applicare la colla su ogni asta aggiunta allo scafo, in modo che siano attaccate l'una all'altra e alle coste. Per coprire gli spazi vuoti lasciati nello scafo dalle aste, realizzare dei pezzi E1 a misura. Applicare la colla bianca e incollare i pezzi per chiudere lo scafo. Una volta chiuso il fasciame dello scafo, carteggiarlo. Carteggiare l'intera superficie della fodera e le teste dei chiodini per renderle a filo con la fodera. La superficie deve essere liscia e uniforme. Sia la prua che la poppa devono essere come mostrato nell'immagine.

F-G. Applicare la colla a contatto (colla per ciabattini) sull'area dello scafo mostrata nelle immagini. Applicare la colla a contatto anche sulle strisce di rivestimento F1. Quando la colla non si attacca alle dita, è il momento di incollare i pezzi. Tagliare le strisce di rivestimento nella misura desiderata. Strofinare le strisce di rivestimento con il manico di legno di un attrezzo per farle aderire saldamente. Continuare a rivestire lo scafo dalla prima striscia di rivestimento verso il basso e dalla falsa chiglia verso l'alto. Realizzare i pezzi G1 a misura per chiudere gli spazi lasciati dal fasciame. Quindi carteggiare il fasciame con carta vetrata a grana fine per ottenere una superficie fine e uniforme. Realizzare i pezzi da G2 a G4 e dipingerli di grigio (rif. 19412). Praticare un foro di ø6 mm nell'area di poppa, che arriva fino al ponte. Questo foro servirà per montare in seguito la pala del timone, vedi pagina M. Realizzare e aggiungere le parti mostrate nelle immagini.

H. Carteggiare e verniciare le parti da H1 a H4 in grigio (rif. 19412). Incollare quindi le parti allo scafo. A questo punto della costruzione, lo scafo può essere verniciato. Quindi carteggiare lo scafo con una levigatrice a grana fine (cod. art. 19155). Rimuovere la polvere di lucidatura con una spazzola asciutta. Se si desidera lasciare lo scafo con il colore del legno visibile, applicare una seconda mano di vernice e lasciarla asciugare. Se si desidera verniciare lo scafo, procedere come segue: applicare prima il primer (rif. 19418) su tutto lo scafo. Una volta asciutto, carteggiare lo scafo fino a ottenere una finitura fine. Isolare l'area mostrata nella foto con del nastro adesivo. Dipingere la parte inferiore dello scafo di rosso (rif. 19402). Quindi, seguendo la stessa procedura, isolare e dipingere lo scafo con i colori nero (rif. 19396) e grigio (rif. 19412).

I. Montare i rinforzi da i1 a i5 a prua e a poppa dello scafo, fissandoli con i pezzi A. Montare poi i pezzi i6 a poppa, uno per ogni lato dello scafo. Tagliare quindi a misura le aste da i7 a i10 e incollarle su entrambi i lati dello scafo come mostrato nelle immagini. Praticare i fori necessari per inserire i golfari B e le altre parti come mostrato nelle immagini. Decorare la pala del timone e aggiungere le parti mostrate nelle immagini. Inserire e fissare la pala del timone con i relativi alberi.

J-K-L. Per realizzare le parti da J1 a J3, bagnare prima le aste. Quindi curvarle leggermente con un ferro da stiro caldo. Adattare e incollare i pezzi come indicato nelle immagini. Decorare i pezzi con i colori indicati nelle immagini, tinta sapeli, (Ref.19420), nero, (Ref.19396), bianco, (Ref.19395), rosso, (Ref.19402) e grigio, (Ref.19412). Per montare alcuni dei pezzi, è necessario praticare dei fori nel ponte. Aggiungere i pezzi alla barca usando la sagoma PL-01 come riferimento.

M. Modellare i pezzi M1 con una pinza. Tagliare a misura il pezzo M2 del camino. Aggiungere i pezzi M2 e B al camino e decorarlo con i colori grigio (rif. 19412) e nero (rif. 19396). Costruire il capanno e dipingerlo di grigio (rif. 19412). Dipingere le parti M10 in bianco (rif. 19395) e nero (rif. 19396). Costruire il gruppo del timone e decorarlo con i colori indicati nelle immagini. Costruire il carabottino con i pezzi M19. Tagliarlo a misura e montarlo con i pezzi da M20 a M22. Decorare e montare tutte le parti del ponte come indicato nelle immagini.

N-O-P. Costruire i pezzi come mostrato nelle immagini. Per unire le catene dovrete aprire le maglie con le pinze e unirle con gli anelli e i golfari B, indicati nelle immagini. Costruire e decorare la passerella. Quindi, aggiungete i pilastri e passate i fili per costruire le ringhiere. Dovrete regolare le ringhiere con porzioni di filo di ottone. Continuare a realizzare e posizionare i pezzi come mostrato nelle foto. Utilizzare la sagoma PL-01 come riferimento per l'installazione.

Q-R. Dipingere i pezzi Q1 e Q2 di nero (Rif. 19396), quindi evidenziare i loro rilievi con la tecnica del pennello asciutto, con il bianco (Rif. 19395). Aggiungere le coste E ai gruppi di ancoraggio utilizzando il filo C e gli anelli Q3. Per realizzare le lande delle sartie, rimuovere prima i pezzi Q6 dalla piastra che li raggruppa e, con una pinza, piegare l'estremità stretta. Inserire un anello Q3 e un anello G. Sagomare la landa delle sartie e fissarla allo scafo con i pezzi A. La posizione approssimativa delle lande delle sartie è visibile sulla sagoma PL-01. Per realizzare le ringhiere dello scafo, inserire e fissare i piloni al ponte. Si noti che esistono diversi tipi di piloni. Inserire quindi i pezzi di corda attraverso i loro fori. Applicare la colla e tagliare il filo in eccesso. Decorare i pezzi da R1 a R4 in grigio (rif. 19412). Incollare i pezzi da R1 a R4 sui pilastri. Dipingere le etichette R5 con lo stesso colore grigio e incollarle sull'area dello scafo mostrata nelle immagini. Seguire le istruzioni riportate nelle immagini sottostanti per costruire le quattro barche. È consigliabile identificare i pezzi di ogni barca e rimuoverli dalla piastra che li raggruppa separatamente per non confonderli. Una volta costruiti gli scheletri, carteggiarli e formarli con i pezzi R20. Rivestire le barche per renderle fini, quindi dipingere e aggiungere i pezzi indicati nelle immagini.

S. Realizzare le parti da S1 a S4. Costruire i gruppi ottici di posizione e decorarli con i colori indicati nelle immagini. Inserire e incollare un bullone a J in ogni foro come indicato nelle immagini. Tagliare i tessuti di S6 utilizzando la sagoma PL-01. Incollarli sulle barche e dipingerli di verde (rif. 19407). Utilizzare la sagoma per realizzare i cordini per le barche e posizionarli sulla barca. Costruire la base e dipingerla con il color sapeli (rif. 19420). Dipingere il pezzo S12 in nero (rif. 19396) ed evidenziare i rilievi in grigio (rif. 19412).

ALBERI

Per realizzare gli alberi, il primo passo da seguire è quello di tagliare le aste secondo le misure indicate nell'elenco dei pezzi, oppure prenderle direttamente dai piani che sono stampati in scala 1/1.

Tutti gli alberi e i longheroni hanno una certa conicità che deve essere rispettata.

Per rastremare gli alberi, carteggiare le aste (con una levigatrice), aumentando l'usura dell'asta man mano che ci si avvicina all'estremità in cui si vuole diminuire il diametro.

Ruotare l'asta in modo che l'usura sia uguale lungo tutto il contorno fino a raggiungere il diametro indicato sul disegno.

Per realizzare la conicità delle aste, eseguire le stesse operazioni, ma questa volta su entrambe le estremità dell'asta.

È necessario colorare o dipingere le aste a seconda del modello che si sta costruendo.

Per realizzare correttamente gli alberi di questo modello, è necessario tenere conto di quanto segue:

- I piani
- Le immagini dettagliate degli alberi
- Le misure e la descrizione dei materiali nella distinta pezzi
- Le schede "IP" di identificazione dei pezzi
- La sagoma PL-01

Gli alberi devono essere smaltati e alcune delle parti che li compongono devono essere dipinte. Vedere le foto di dettaglio degli alberi.

Una volta assemblati e verniciati, devono essere equipaggiati con il sartiame (stroppi, quarnali, golfari, bozzelli, ecc.) e fissati alla barca.

Gli alberi devono essere inseriti fino all'arresto nelle prese della falsa chiglia.

SARTIAME

Per realizzare il sartiame di questa barca, seguite l'ordine alfabetico delle figure stampate sui piani, che indicano l'ordine di collocazione di cime, travi, bozzelli, vele, ecc. L'elenco delle parti vi guiderà sul tipo di materiali e sulle misure da utilizzare.

Per simulare l'invecchiamento delle vele, è possibile immergerle in un infuso di tè, senza farle bollire, e lasciarle asciugare ben stropicciate.

Vanno collocate senza stirarle, per dar loro corpo.

A. Die Teile vorsichtig mit einem Schneidewerkzeug (Cutter) herauslösen und die kleinen Befestigungsenden entfernen. Anschließend die mit feinem Schmirgelpapier glätten, um die Reste der Befestigungsenden und eventuelle Holzspäne zu entfernen. Die auf den Abbildungen gezeigten Teile in der angegebenen Reihenfolge einsetzen und aufkleben. Vor dem Aufkleben der Spanten A2 bis A13 sicherstellen, dass diese korrekt am Anschlag sitzen und mit den dazugehörigen Einkerbungen des falschen Kiels A1 abschließen. Die Spanten müssen vollkommen senkrecht auf dem falschen Kiel die Abdeckung passt, damit die Decks danach gut eingesetzt werden können. Für diesen Schritt weißen Leim (Ref.19200) verwenden. Die Teile fixieren, bis der Kleber getrocknet ist. Die Teile A13 bis A23 einsetzen und wie abgebildet aufkleben. Dabei die erste Plankenreihe an der Bleistiftlinie ausrichten. Zum Kleben Kontaktkleber verwenden (Schusterleim). Mit dem Holzstiel eines Werkzeugs das Furnier kräftig auf das Deck reiben, bis es fest haftet. Das Deck mit der Oberseite nach unten aufsetzen und die überstehenden Teile der Leisten abschneiden. Abschließend Linien ziehen und Markierungen anbringen, um die Schiffsbeplankung zu simulieren. Das Deck glatt schmirgeln und Satinlack auftragen (Ref. 19419).

B-C. Den oberen Teil des Spanten A8 glatt schmirgeln und grau lackieren (Ref. 19412). Weißen Leim auftragen und Deck A24 aufkleben. Um das Deck zu immobilisieren, kann auch Sekundenkleber verwendet werden (Ref. 19201). Die gleichen Arbeitsschritte zum Verkleiden und Aufsetzen von Deck B1 durchführen. Darauf achten, dass die oberen Ende der Spanten in den Aussparungen des Decks sitzen. Deck B1 anpassen und aufkleben. Den Rumpf mit der Oberseite nach unten anbringen und vom Bug in Richtung Heck glatt schleifen. Die Kanten der Spanten glätten, aber dabei nicht das ursprüngliche Profil verändern. Beim Glätten des Rumpfs darauf achten, dass beide Seiten symmetrisch zueinander sein müssen. Die ganze Oberfläche des Rumpfs nach und nach vorsichtig glätten. Mit der Leiste B3 testen, ob eine gleichmäßige Oberfläche hergestellt wurde. Dazu die Leiste an die Spanten drücken und hin und her schieben und prüfen, ob sie sich der Form des Rumpfs anpasst. Die Teile C1 und C2 anfertigen, grau lackieren (Ref. 19412) und wie auf der Abbildung gezeigt aufkleben. Die Innenseite der Schanzverkleidung C3 lackieren. Leim auftragen, Schanzverkleidung C3 aufkleben und mit den Stiften A befestigen. Dazu kann man einen Nagler (Ref.19108) oder einen Hammer verwenden.

D-E. Ein paar Leisten D1 etwa 15 Minuten lang in Wasser einweichen, damit sie biegsamer werden. Unmittelbar danach die Leisten mit einem Bügeleisen oder einem zylindrischen Gegenstand mit einem Durchmesser von etwa 10 cm zurechtbiegen. Leim auftragen, die erste Leiste D1 passend auf die Oberseite des Decks kleben und mit den Stiften A festnageln. An jeder Stelle, an der die Leiste einen Spanten schneidet, muss ein Stift angebracht werden. Die überstehenden Enden anschließend bündig zum Bugbereich abschneiden. Mit dem Auskleiden des Rumpfes fortfahren, wie auf den Abbildungen gezeigt. Auf jede Leiste, die am Rumpf angebracht werden soll, Klebstoff auftragen, um sie erst untereinander und dann mit den Spanten zu verbinden. Zur Abdeckung der Lücken im Rumpf, die durch die Leisten entstanden sind, maßgeschneiderte Teile E1 anfertigen. Weißleim auftragen und die Teile zusammenkleben, um den Rumpf zu schließen. Nach dem Schließen der Rumpfauskleidung, diesen glatt schmirgeln. Die Oberfläche des Rumpfs glatt schmirgeln und die Stiftpföpfe abfeilen, bis sie auf einer Höhe mit den Plankenreihen sind. Es muss eine glatte und gleichmäßige Oberfläche entstehen. Bug und Heck sollten so aussehen, wie auf der Abbildung gezeigt.

F-G. Kontaktkleber (Schusterleim) auf die Rumpfbereiche auftragen, die auf den Abbildungen zu sehen sind. Ebenfalls Kontaktkleber auf die Plankenreihe F1 auftragen. Wenn der Kleber nicht mehr an den Fingern festklebt, die Teile zusammenkleben. Die Plankenreihen passend zurechtschneiden. Die Plankenreihe mit dem Holzstiel eines Werkzeugs andrücken, damit die Teile fest haften. Anschließend den Rumpf von der ersten Plankenreihe nach unten und vom falschen Kiel nach oben verkleiden. Die Teile G1 nach Maß anfertigen, um die Zwischenräume in der Beplankung zu schließen. Anschließend die Beplankung mit feinem Schleifpapier abschmirgeln, um eine feine und gleichmäßige Oberfläche herzustellen. Die Teile G2 bis G4 anfertigen und grau lackieren (Ref.19412). In Bugbereich eine ø6 mm große Öffnung anbringen, die bis zum Deck geht. Diese Öffnung ist für das Einsetzen des Ruderblattes vorgesehen, siehe dazu Seite M. Die Teile, die auf den Abbildungen zu sehen sind, anfertigen und verzieren.

H. Die Teile H1 bis H4 glatt schmirgeln und grau lackieren (Ref.19412). Anschließend die Teile auf dem Rumpf aufkleben. In dieser Bastelphase kann der Rumpf lackiert werden. Anschließend mit einem feinkörnigen Schmirgelschwamm (Ref. 19155) glätten. Den dabei entstehenden Staub mit feinem, trockenem Pinsel entfernen. Wenn der Rumpf in der Farbe des Holzes belassen werden soll, eine zweite Schicht Lack auftragen und trocknen lassen. Zum Anmalen des Rumpfs: Zunächst die Grundierung (Ref.19418) auf den gesamten Rumpf auftragen. Nach dem Trocknen den Rumpf glatt schmirgeln. Den in der Abbildung gezeigten Bereich mit Kreppband abkleben. Die Unterseite des Rumpfs dunkelrot lackieren (Ref.19402). Anschließend das Verfahren wiederholen, die entsprechenden Bereiche abkleben und den Rumpf schwarz (Ref. 19396) und grau (Ref. 19412) lackieren.

I. Die Verstrebungen i1 bis i5 am Bug und am Heck anbringen und mit den Stiften A befestigen. Die Teile i6 achtern (am H) anbringen, eines auf jeder Seite des Rumpfs. Anschließend die Leisten i7 bis i10 nach Maß zurechtschneiden und an beiden Rumpfseiten ankleben, wie auf den Abbildungen gezeigt. Die erforderlichen Öffnungen für die Ösenstifte B und die anderen Teile, die auf den Abbildungen zu sehen sind, anbringen. Das Steuerblatt dekorieren und die auf den Abbildungen gezeigten Teile hinzufügen. Das Steuerblatt einsetzen und mit den Achsen befestigen.

J-K-L. Zur Herstellung der Teile J1 bis J3 werden zunächst die Leisten angefeuchtet. Anschließend mit einem warmen Bügeleisen biegen. Die auf den Abbildungen gezeigten Teile anpassen und aufkleben. Die Stücke in den auf den Abbildungen angegebenen Farben anmalen: Sapelli-Holz (Ref. 19420), Schwarz (Ref. 19396), Weiß (Ref. 19395), Rot (Ref. 19402) und Grau (Ref. 19412). Für einige der Teile müssen vor dem Anbringen Löcher in das Deck gebohrt werden. Die Teile nacheinander auf dem Schiff anbringen, dazu die Schablone PL-01 als Vorlage verwenden.

M. Die Teile M1 mit einer Zange formen. Den Schornstein aus Teil M2 zurechtschneiden. Die Teile M2 und B am Schornstein anbringen und den Schornstein in den Farben Grau (Ref. 19412) und Schwarz (Ref. 19396) anmalen. Den Aufbau anfertigen und grau (Ref.19412) lackieren. Die Teile M10 weiß (Ref.19395) und schwarz (Ref.19396) anmalen. Die Steuerbaugruppe anfertigen und in den auf den Abbildungen angegebenen Farben anmalen. Die Grätting aus den Teilen M19 anfertigen. Nach Maß zurechtschneiden zurecht und mit den Teilen M20 bis M22 einrahmen. Alle Teile des Decks wie auf den Abbildungen gezeigt verzieren und anbringen.

N-O-P. Die Teile, die auf den Abbildungen zu sehen sind, anfertigen. Um die Ketten miteinander zu verbinden, die Glieder mit einer Zange öffnen und mit den Ösen und Ösenstifte B verbinden, wie auf den Abbildungen gezeigt. Die Brücke über das Deck bauen und dekorieren. Die Ständer für das Geländer anbringen und ziehen den Draht durchziehen, um das Geländer zu fertigen. Den Draht dazu nach Maß zurechtschneiden, während die Geländer formen. Die Teile wie auf den Abbildungen gezeigt anfertigen und anbringen. Die Schablone PL-01 als Vorlage für die korrekte Platzierung verwenden.

Q-R. Die Teile Q1 und Q2 schwarz lackieren (Ref. 19396) und anschließend deren Reliefs mit Trockenpinseltechnik in Weiß hervorheben (Ref. 19395). Die Gienblöcke E mit dem Draht C und den Ösen Q3 an den Ankerbaugruppen befestigen. Zur Herstellung der Püttings zunächst die Teile Q6 aus dem Plättchen lösen und mit einer Zange das schmale Ende zurechtbiegen. Eine Öse Q3 und einen Klampbock G einsetzen. Die Püttings formen und mit Stiften A am Rumpf befestigen. Anhand der PL-01-Schablone kann die ungefähre Position der Püttings bestimmt werden. Um die Reling des Rumpfs anzufertigen, die Relingständer auf das Deck setzen und befestigen. Es gibt mehrere Arten von Relingständern. Anschließend den Draht durch die Öffnungen ziehen. Kleber auftragen und überschüssigen Draht abschneiden. Die Teile R1 bis R4 in Grau anmalen (Ref. 19412). Die Teile R1 bis R4 auf Ständer kleben. Die Schilder R5 in der gleichen grauen Farbe anmalen und wie auf den Abbildungen gezeigt auf den Rumpf kleben. Die vier Beiboote wie auf den Abbildungen gezeigt zusammenbauen. Dazu die Einzelteile der verschiedenen Boote identifizieren und sie aus dem Blatt herauslösen, um Verwechslungen zu vermeiden. Die fertigen Bootskelette glatt schleifen und mit den Teilen R20 verkleiden. Die Boote mit Kitt bestreichen, um eine glatte Oberfläche zu erhalten, und anschließend anmalen und die auf den Abbildungen gezeigten Teile aufkleben.

S. Die Teile S1 bis S4 anfertigen. Die Positionslichter zusammenbauen und in den auf den Abbildungen gezeigten Farben anmalen. In jede Öffnung einen Belegnagel J einsetzen und aufkleben, wie auf den Abbildungen gezeigt. Den Stof S6 mithilfe der Schablone PL-01 zurechtschneiden. Über die Boote kleben und grün lackieren (Ref.19407). Mit der Schablone die Ständer für die Beiboote anfertigen und auf dem Schiff aufstellen. Den Sockel anfertigen und in Sapelli-Holz lackieren (Ref.19420). Teil S12 schwarz lackieren (Ref. 19396) und die Reliefs in Grau hervorheben (Ref. 19412).

BEMASTUNG

Zur Herstellung der Masten müssen zuerst die Stäbe entsprechend der Maße zurecht geschnitten werden, die in der Teileliste angegeben sind oder die direkt anhand der Skizze abgemessen wurde. Die Skizzen sind im Maßstab 1/1 angefertigt.

Alle Masten und Rahen müssen leicht konisch verlaufen und vor dem Einbau entsprechen vorbereitet werden.

Um die Masten in Konusform zu bringen, müssen die Masten (mit einer Feile) zurecht geschliffen werden, und zwar in der Form, dass sie nach oben hin verjüngt werden. Die Stäbe dabei drehen und an allen Seiten gleichmäßig abschleifen, bis sie zu dem auf der Skizze angegebenen Durchmesser passen. Um die Rahen in Konusform zu bringen, ebenso verfahren, allerdings hier an beiden Enden der Stangen. Die Stäbe in Abhängigkeit von dem Modell färben oder anmalen.

Um die Masten dieses Schiffsbaumodells richtig vorzubereiten, müssen die folgenden Punkte beachtet werden:

- Die Skizzen
- Detailfotos der Masten
- Maße und Materialien der Teileliste
- IP-Blätter zur Identifikation der Bauteile
- Schablone PL-01

Die Masten müssen lackiert werden und einige der Einzelteile der Masten müssen angemalt werden. Siehe dazu die Fotos mit der allgemeinen Ansicht der Masten. Nach Aufstellen und Lackieren der Masten wird die Takelung (Stroppe, Rollenblöcke, Ösen, Blockrollen usw.) an den Masten und dann am Schiff befestigt. Die Masten müssen eingesetzt werden, bis sie an die Einkerbungen des falschen Kiels stoßen.

TAKELAGE

Zur Takelung des Schiffsmodells die alphabetische Reihenfolge der Abbildungen befolgen, auf denen die Anbringung der Takelung (Faden, Klampböcke, Blockrollen usw.) erläutert wird. Sie sind in Rot hervorgehoben. Auf der Teileliste sehen Sie, welche Materialien zum Bau des Modells notwendig sind. Zur künstlichen Alterung der Segel die Stoffstücke in Tee legen (nicht kochen) und trocknen lassen, bis die Stoffe faltig werden. Die Segel ohne vorheriges Bügeln anbringen, damit sie Volumen haben.

Lista de piezas / Parts List / Liste des pièces / Teileliste / Elenco delle parti

<i>Nº/No./ Nº / Nr. No</i>	<i>Cantidad / Quantity / Quantité / Menge / Quantità</i>	<i>Medidas / Measurements / Dimensions / Maße / Misure</i>	<i>Material / Material / Matériau / Material / Materiale</i>
A1	1	Precortado / Precut / Prédécoupé / Vorgeschnitten/ Pretagliato	Tablero / Plywood / Planche / Sperrholz / Tavola
A2-A13	12	Precortado / Precut / Prédécoupé / Vorgeschnitten/ Pretagliato	Tablero / Plywood / Planche / Sperrholz / Tavola
A14-A23	20	Precortado / Precut / Prédécoupé / Vorgeschnitten/ Pretagliato	Tablero / Plywood / Planche / Sperrholz / Tavola
A24	1	Precortado / Precut / Prédécoupé / Vorgeschnitten/ Pretagliato	Tablero / Plywood / Planche / Sperrholz / Tavola
A25	26	0,6x5x290	Sicomoro / Sycamore / Sycomore / Bergahorn / Sicomoro
B1	1	Precortado / Precut / Prédécoupé / Vorgeschnitten/ Pretagliato	Tablero / Plywood / Planche / Sperrholz / Tavola
B2	24	0,6x5x200	Sicomoro / Sycamore / Sycomore / Bergahorn / Sicomoro
B3	1	2x5x600	Tilo / Lime wood / Tilleul / Linde / Tiglio
C1	4	1x3x17	Tilo / Lime wood / Tilleul / Linde / Tiglio
C2	2	1x3x57	Tilo / Lime wood / Tilleul / Linde / Tiglio
C3	2	Precortado / Precut / Prédécoupé / Vorgeschnitten/ Pretagliato	Tablero / Plywood / Planche / Sperrholz / Tavola
D1	4	2x5x290	Tilo / Lime wood / Tilleul / Linde / Tiglio
D2	16	2x5x600	Tilo / Lime wood / Tilleul / Linde / Tiglio
E1	32	2x5x600	Tilo / Lime wood / Tilleul / Linde / Tiglio
F1	46	0,6x5x600	Sapelly / Sapelli / Sapelli / Sapelly-Holz / Sapelli
G1	12	0,6x5x600	Sapelly / Sapelli / Sapelli / Sapelly-Holz / Sapelli
G2	2	1x3x190	Tilo / Lime wood / Tilleul / Linde / Tiglio
G3	1	1x3x5	Tilo / Lime wood / Tilleul / Linde / Tiglio
G4	26	1x3x11	Tilo / Lime wood / Tilleul / Linde / Tiglio
G5-G9	5	Precortado / Precut / Prédécoupé / Vorgeschnitten/ Pretagliato	Tablero / Plywood / Planche / Sperrholz / Tavola
H1-H4	7	Precortado / Precut / Prédécoupé / Vorgeschnitten/ Pretagliato	Tablero / Plywood / Planche / Sperrholz / Tavola
i1-i5	26	Preformado / Preformed/ Préformé / Vorgeformt / Preformato	Metal / Metal / Metal / Metall / Metallo
i6	2	Preformado / Preformed/ Préformé / Vorgeformt / Preformato	Metal / Metal / Metal / Metall / Metallo
i7	2	1x3x47	Tilo / Lime wood / Tilleul / Linde / Tiglio
i8	4	1x3x9	Tilo / Lime wood / Tilleul / Linde / Tiglio
i9	2	1x3x75	Tilo / Lime wood / Tilleul / Linde / Tiglio
i10	4	1x3x600	Tilo / Lime wood / Tilleul / Linde / Tiglio
i11	2	Preformado / Preformed/ Préformé / Vorgeformt / Preformato	Metal / Metal / Metal / Metall / Metallo
i12	5	Preformado / Preformed/ Préformé / Vorgeformt / Preformato	Metal / Metal / Metal / Metall / Metallo
i13-i15	6	Preformado / Preformed/ Préformé / Vorgeformt / Preformato	Metal / Metal / Metal / Metall / Metallo
i16	1	Precortado / Precut / Prédécoupé / Vorgeschnitten/ Pretagliato	Tablero / Plywood / Planche / Sperrholz / Tavola
i17	2	ø1,5x8	Latón / Brass / Latón / Messing / Ottone
i18	1	Preformado / Preformed/ Préformé / Vorgeformt / Preformato	Metal / Metal / Metal / Metall / Metallo
i19	1	ø6	Latón / Brass / Latón / Messing / Ottone
i20	1	1x30	Latón / Brass / Latón / Messing / Ottone
i21	4	1x3x14	Tilo / Lime wood / Tilleul / Linde / Tiglio
J1	2	3x3x95	Tilo / Lime wood / Tilleul / Linde / Tiglio
J2	1	3x3x20	Tilo / Lime wood / Tilleul / Linde / Tiglio
J3	2	1x3x188	Tilo / Lime wood / Tilleul / Linde / Tiglio
J4	4	Preformado / Preformed/ Préformé / Vorgeformt / Preformato	Metal / Metal / Metal / Metall / Metallo
J5	1	Precortado / Precut / Prédécoupé / Vorgeschnitten/ Pretagliato	Tablero / Plywood / Planche / Sperrholz / Tavola
J6	2	1x3x18	Tilo / Lime wood / Tilleul / Linde / Tiglio
J7	2	1x3x20	Tilo / Lime wood / Tilleul / Linde / Tiglio
J8	1	Precortado / Precut / Prédécoupé / Vorgeschnitten/ Pretagliato	Tablero / Plywood / Planche / Sperrholz / Tavola
J9	5	1x3x10	Tilo / Lime wood / Tilleul / Linde / Tiglio
J10	3	Preformado / Preformed/ Préformé / Vorgeformt / Preformato	Metal / Metal / Metal / Metall / Metallo
J11-J12	3	Precortado / Precut / Prédécoupé / Vorgeschnitten/ Pretagliato	Tablero / Plywood / Planche / Sperrholz / Tavola
J13-J14	3	Preformado / Preformed/ Préformé / Vorgeformt / Preformato	Metal / Metal / Metal / Metall / Metallo
J15	1	2x5x12	Tilo / Lime wood / Tilleul / Linde / Tiglio
J16	1	Preformado / Preformed/ Préformé / Vorgeformt / Preformato	Metal / Metal / Metal / Metall / Metallo
J17	2	ø1x15	Latón / Brass / Latón / Messing / Ottone

Lista de piezas / Parts List / Liste des pièces / Teileliste / Elenco delle parti

<i>Nº/No./ N° / Nr. No</i>	<i>Cantidad / Quantity / Quantité / Menge / Quantità</i>	<i>Medidas / Measurements / Dimensions / Maße / Misure</i>	<i>Material / Material / Matériau / Material / Materiale</i>
J18	1	Preformado / Preformed/ Préformé / Vorgeformt / Preformato	Metal / Metal / Metal / Metall / Metallo
J19	4	Preformado / Preformed/ Préformé / Vorgeformt / Preformato	Metal / Metal / Metal / Metall / Metallo
J20	1	3x3x7	Tilo / Lime wood / Tilleul / Linde / Tiglio
K1	2	Precortado / Precut / Prédécoupé / Vorgeschnitten/ Pretagliato	Tablero / Plywood / Planche / Sperrholz / Tavola
K2	2	Precortado / Precut / Prédécoupé / Vorgeschnitten/ Pretagliato	Tablero / Plywood / Planche / Sperrholz / Tavola
K3	1	Precortado / Precut / Prédécoupé / Vorgeschnitten/ Pretagliato	Tablero / Plywood / Planche / Sperrholz / Tavola
K4	2	1x3x22	Tilo / Lime wood / Tilleul / Linde / Tiglio
K5	2	1x3x29	Tilo / Lime wood / Tilleul / Linde / Tiglio
K6	1	14x32	Acetato / Acetate / Acétate / Acetat / Acetato
K7	18	<u>ø0,50x9</u>	Latón / Brass / Latón / Messing / Ottone
K8	1	<u>ø1x32</u>	Latón / Brass / Latón / Messing / Ottone
K9	2	<u>1x3x40</u>	Tilo / Lime wood / Tilleul / Linde / Tiglio
K10	2	<u>1x3x29</u>	Tilo / Lime wood / Tilleul / Linde / Tiglio
K11	1	Precortado / Precut / Prédécoupé / Vorgeschnitten/ Pretagliato	Tablero / Plywood / Planche / Sperrholz / Tavola
K12	1	29x38	Composite / Composite / Composite / Composite / Composite
K13	2	1x3x41	Tilo / Lime wood / Tilleul / Linde / Tiglio
K14	2	1x3x32	Tilo / Lime wood / Tilleul / Linde / Tiglio
K15	1	1x3x35	Tilo / Lime wood / Tilleul / Linde / Tiglio
K16	12	1x3x12	Tilo / Lime wood / Tilleul / Linde / Tiglio
K17	2	Preformado / Preformed/ Préformé / Vorgeformt / Preformato	Metal / Metal / Metal / Metall / Metallo
K18	2	Preformado / Preformed/ Préformé / Vorgeformt / Preformato	Madera / Wood / Bois / Holz / Legno
L1	2	Preformado / Preformed/ Préformé / Vorgeformt / Preformato	Metal / Metal / Metal / Metall / Metallo
L2	1	1x3x34	Tilo / Lime wood / Tilleul / Linde / Tiglio
L3	2	ø0,15x55	Hilo crudo / Raw thread / Fil brut / Rohes Baumwollfaden / Filo crudo
L4	3	ø1,5x14	Latón / Brass / Latón / Messing / Ottone
L5	3	ø0,5x100	Latón / Brass / Latón / Messing / Ottone
L6	6	ø0,50x55	Latón / Brass / Latón / Messing / Ottone
L7	1	Preformado / Preformed/ Préformé / Vorgeformt / Preformato	Madera / Wood / Bois / Holz / Legno
L8	14	1x3x17	Tilo / Lime wood / Tilleul / Linde / Tiglio
L9	4	Precortado / Precut / Prédécoupé / Vorgeschnitten/ Pretagliato	Tablero / Plywood / Planche / Sperrholz / Tavola
L10	1	Preformado / Preformed/ Préformé / Vorgeformt / Preformato	Metal / Metal / Metal / Metall / Metallo
L11	4	1x3x20	Tilo / Lime wood / Tilleul / Linde / Tiglio
L12	2	1x3x16	Tilo / Lime wood / Tilleul / Linde / Tiglio
L13-L15	8	Precortado / Precut / Prédécoupé / Vorgeschnitten/ Pretagliato	Tablero / Plywood / Planche / Sperrholz / Tavola
L16	10	1x5x18	Tilo / Lime wood / Tilleul / Linde / Tiglio
L17	2	Preformado / Preformed/ Préformé / Vorgeformt / Preformato	Latón / Brass / Latón / Messing / Ottone
L18	2	Precortado / Precut / Prédécoupé / Vorgeschnitten/ Pretagliato	Tablero / Plywood / Planche / Sperrholz / Tavola
M1	4	2x33	Latón / Brass / Latón / Messing / Ottone
M2	1	ø10x70	Tilo / Lime wood / Tilleul / Linde / Tiglio
M3-M5	5	Precortado / Precut / Prédécoupé / Vorgeschnitten/ Pretagliato	Tablero / Plywood / Planche / Sperrholz / Tavola
M6	2	22x10	Acetato / Acetate / Acétate / Acetat / Acetato
M7	2	11x10	Acetato / Acetate / Acétate / Acetat / Acetato
M8	5	1x3x30	Tilo / Lime wood / Tilleul / Linde / Tiglio
M9	30	ø0,50x8	Latón / Brass / Latón / Messing / Ottone
M10	2	Preformado / Preformed/ Préformé / Vorgeformt / Preformato	Metal / Metal / Metal / Metall / Metallo
M11	4	2x3x25	Tilo / Lime wood / Tilleul / Linde / Tiglio
M12	2	Preformado / Preformed/ Préformé / Vorgeformt / Preformato	Metal / Metal / Metal / Metall / Metallo
M13	1	Preformado / Preformed/ Préformé / Vorgeformt / Preformato	Madera / Wood / Bois / Holz / Legno
M14	1	Preformado / Preformed/ Préformé / Vorgeformt / Preformato	Metal / Metal / Metal / Metall / Metallo
M15	1	Preformado / Preformed/ Préformé / Vorgeformt / Preformato	Metal / Metal / Metal / Metall / Metallo
M16	1	Preformado / Preformed/ Préformé / Vorgeformt / Preformato	Metal / Metal / Metal / Metall / Metallo











Lista de piezas / Parts List / Liste des pièces / Teileliste / Elenco delle parti

<i>Nº/No./ Nº / Nr. No</i>	<i>Cantidad / Quantity / Quantité / Menge / Quantità</i>	<i>Medidas / Measurements / Dimensions / Maße / Misure</i>	<i>Material / Material / Matériau / Material / Materiale</i>
M17	1	ø1,50x12	Latón / Brass / Latón / Messing / Ottone
M18	1	ø1,50x9	Latón / Brass / Latón / Messing / Ottone
M19	9	Preformado / Preformed/ Préformé / Vorgeformt / Preformato	Madera / Wood / Bois / Holz / Legno
M20	1	1x3x40	Tilo / Lime wood / Tilleul / Linde / Tiglio
M21	2	1x3x15	Tilo / Lime wood / Tilleul / Linde / Tiglio
M22	2	1x3x11	Tilo / Lime wood / Tilleul / Linde / Tiglio
M23	2	Preformado / Preformed/ Préformé / Vorgeformt / Preformato	Metal / Metal / Metal / Metall / Metallo
M24	2	Preformado / Preformed/ Préformé / Vorgeformt / Preformato	Metal / Metal / Metal / Metall / Metallo
M25	1	Preformado / Preformed/ Préformé / Vorgeformt / Preformato	Metal / Metal / Metal / Metall / Metallo
N1	1	Preformado / Preformed/ Préformé / Vorgeformt / Preformato	Madera / Wood / Bois / Holz / Legno
N2	14	ø0,50x10	Latón / Brass / Latón / Messing / Ottone
N3	4	Preformado / Preformed/ Préformé / Vorgeformt / Preformato	Metal / Metal / Metal / Metall / Metallo
N4	4	1x5x11	Tilo / Lime wood / Tilleul / Linde / Tiglio
N5	4	Preformado / Preformed/ Préformé / Vorgeformt / Preformato	Metal / Metal / Metal / Metall / Metallo
N6	1	1x175	Latón / Brass / Latón / Messing / Ottone
N7	1	ø0,50x30	Latón / Brass / Latón / Messing / Ottone
N8	1	2x3x19	Tilo / Lime wood / Tilleul / Linde / Tiglio
N9	1	2x3x19	Tilo / Lime wood / Tilleul / Linde / Tiglio
N10	2	2x3x19	Tilo / Lime wood / Tilleul / Linde / Tiglio
N11	1	2x5x15	Tilo / Lime wood / Tilleul / Linde / Tiglio
N12	2	Preformado / Preformed/ Préformé / Vorgeformt / Preformato	Metal / Metal / Metal / Metall / Metallo
N13	2	Preformado / Preformed/ Préformé / Vorgeformt / Preformato	Metal / Metal / Metal / Metall / Metallo
O1	8	Preformado / Preformed/ Préformé / Vorgeformt / Preformato	Metal / Metal / Metal / Metall / Metallo
O2	2	Preformado / Preformed/ Préformé / Vorgeformt / Preformato	Metal / Metal / Metal / Metall / Metallo
O3	4	ø1,5x50	Latón / Brass / Latón / Messing / Ottone
O4	8	ø0,15x100	Hilo crudo / Raw thread / Fil brut / Rohes Baumwollfaden / Filo crudo
O5	4	2x3x18	Tilo / Lime wood / Tilleul / Linde / Tiglio
O6	1	Precortado / Precut / Prédécoupé / Vorgeschnitten/ Pretagliato	Tablero / Plywood / Planche / Sperrholz / Tavola
O7	1	Preformado / Preformed/ Préformé / Vorgeformt / Preformato	Madera / Wood / Bois / Holz / Legno
O8	4	ø1,5x17	Latón / Brass / Latón / Messing / Ottone
O9	2	ø1,5x30	Latón / Brass / Latón / Messing / Ottone
O10	16	Preformado / Preformed/ Préformé / Vorgeformt / Preformato	Metal / Metal / Metal / Metall / Metallo
O11	6	ø0,50x75	Latón / Brass / Latón / Messing / Ottone
P1	1	ø6x400	Tilo / Lime wood / Tilleul / Linde / Tiglio
P2	2	Preformado / Preformed/ Préformé / Vorgeformt / Preformato	Metal / Metal / Metal / Metall / Metallo
P3	7	Preformado / Preformed/ Préformé / Vorgeformt / Preformato	Metal / Metal / Metal / Metall / Metallo
P4	2	ø0,50x42	Latón / Brass / Latón / Messing / Ottone
P5	11	Preformado / Preformed/ Préformé / Vorgeformt / Preformato	Latón / Brass / Latón / Messing / Ottone
P6	4	ø0,50x15	Metal / Metal / Metal / Metall / Metallo
P7	2	ø0,50x28	Latón / Brass / Latón / Messing / Ottone
P8	8	ø0,50x23	Latón / Brass / Latón / Messing / Ottone
P9	2	Preformado / Preformed/ Préformé / Vorgeformt / Preformato	Latón / Brass / Latón / Messing / Ottone
P10	2	1x3x14	Tilo / Lime wood / Tilleul / Linde / Tiglio
P11	2	Preformado / Preformed/ Préformé / Vorgeformt / Preformato	Latón / Brass / Latón / Messing / Ottone
P12	2	1x120	Latón / Brass / Latón / Messing / Ottone
Q1	2	Preformado / Preformed/ Préformé / Vorgeformt / Preformato	Metal / Metal / Metal / Metall / Metallo
Q2	2	Preformado / Preformed/ Préformé / Vorgeformt / Preformato	Metal / Metal / Metal / Metall / Metallo
Q3	38	ø6	Latón / Brass / Latón / Messing / Ottone
Q4	2	1x85	Latón / Brass / Latón / Messing / Ottone
Q5	2	ø0,15x300	Hilo crudo / Raw thread / Fil brut / Rohes Baumwollfaden / Filo crudo
Q6	6	1x3x10	Tilo / Lime wood / Tilleul / Linde / Tiglio

Lista de piezas / Parts List / Liste des pièces / Teileliste / Elenco delle parti

<i>Nº/No./ N° / Nr. No</i>	<i>Cantidad / Quantity / Quantité / Menge / Quantità</i>	<i>Medidas / Measurements / Dimensions / Maße / Misure</i>	<i>Material / Material / Matériau / Material / Materiale</i>
Q7	4	Preformado / Preformed/ Préformé / Vorgeformt / Preformato	Latón / Brass / Latón / Messing / Ottone
Q8	36	Preformado / Preformed/ Préformé / Vorgeformt / Preformato	Latón / Brass / Latón / Messing / Ottone
Q9	2	Preformado / Preformed/ Préformé / Vorgeformt / Preformato	Metal / Metal / Metal / Metall / Metallo
Q10	2	ø0,15x150	Hilo crudo / Raw thread / Fil brut / Rohes Baumwollfaden / Filo crudo
Q11	6	Preformado / Preformed/ Préformé / Vorgeformt / Preformato	Latón / Brass / Latón / Messing / Ottone
Q12	4	Preformado / Preformed/ Préformé / Vorgeformt / Preformato	Latón / Brass / Latón / Messing / Ottone
Q13	22	Preformado / Preformed/ Préformé / Vorgeformt / Preformato	Latón / Brass / Latón / Messing / Ottone
Q14	10	ø0,50x100	Latón / Brass / Latón / Messing / Ottone
Q15	4	ø0,15x190	Hilo crudo / Raw thread / Fil brut / Rohes Baumwollfaden / Filo crudo
R1-R4	4	Precortado / Precut / Prédécoupé / Vorgeschnitten/ Pretagliato	Tablero / Plywood / Planche / Sperrholz / Tavola
R5	2	Preformado / Preformed/ Préformé / Vorgeformt / Preformato	Latón / Brass / Latón / Messing / Ottone
R6	4	Precortado / Precut / Prédécoupé / Vorgeschnitten/ Pretagliato	Tablero / Plywood / Planche / Sperrholz / Tavola
R7-R17	44	Precortado / Precut / Prédécoupé / Vorgeschnitten/ Pretagliato	Tablero / Plywood / Planche / Sperrholz / Tavola
R18	16	Precortado / Precut / Prédécoupé / Vorgeschnitten/ Pretagliato	Tablero / Plywood / Planche / Sperrholz / Tavola
R19	4	Precortado / Precut / Prédécoupé / Vorgeschnitten/ Pretagliato	Tablero / Plywood / Planche / Sperrholz / Tavola
R20	45	1x3x90	Tilo / Lime wood / Tilleul / Linde / Tiglio
R21	4	Precortado / Precut / Prédécoupé / Vorgeschnitten/ Pretagliato	Tablero / Plywood / Planche / Sperrholz / Tavola
R22	4	Precortado / Precut / Prédécoupé / Vorgeschnitten/ Pretagliato	Tablero / Plywood / Planche / Sperrholz / Tavola
R23	4	Precortado / Precut / Prédécoupé / Vorgeschnitten/ Pretagliato	Tablero / Plywood / Planche / Sperrholz / Tavola
R24	4	2x2x58	Tilo / Lime wood / Tilleul / Linde / Tiglio
S1	4	ø1x30	Latón / Brass / Latón / Messing / Ottone
S2-S3	4	1x5x21	Tilo / Lime wood / Tilleul / Linde / Tiglio
S4	2	1x5x6	Tilo / Lime wood / Tilleul / Linde / Tiglio
S5	2	Preformado / Preformed/ Préformé / Vorgeformt / Preformato	Metal / Metal / Metal / Metall / Metallo
S6	4	40x85	Tilo / Lime wood / Tilleul / Linde / Tiglio
S7	16	ø0,15x100	Hilo crudo / Raw thread / Fil brut / Rohes Baumwollfaden / Filo crudo
S8	8	ø0,15x225	Hilo crudo / Raw thread / Fil brut / Rohes Baumwollfaden / Filo crudo
S9-S11	4	Precortado / Precut / Prédécoupé / Vorgeschnitten/ Pretagliato	Tablero / Plywood / Planche / Sperrholz / Tavola
S12	1	Preformado / Preformed/ Préformé / Vorgeformt / Preformato	Metal / Metal / Metal / Metall / Metallo
S13	6	Preformado / Preformed/ Préformé / Vorgeformt / Preformato	Latón / Brass / Latón / Messing / Ottone
S14	6	Preformado / Preformed/ Préformé / Vorgeformt / Preformato	Latón / Brass / Latón / Messing / Ottone
S15	3	ø3x5	Tilo / Lime wood / Tilleul / Linde / Tiglio
S16	3	ø0,15x60	Hilo crudo / Raw thread / Fil brut / Rohes Baumwollfaden / Filo crudo
T1	4	Preformado / Preformed/ Préformé / Vorgeformt / Preformato	Metal / Metal / Metal / Metall / Metallo
T2	2	1x3x20	Tilo / Lime wood / Tilleul / Linde / Tiglio
T3	2	1x3x75	Tilo / Lime wood / Tilleul / Linde / Tiglio
T4	2	Preformado / Preformed/ Préformé / Vorgeformt / Preformato	Madera / Wood / Bois / Holz / Legno

Lista de piezas / Parts List / Liste des pièces / Teileliste / Elenco delle parti

Nº/No./ Nº / Nr. / No	Descripción / Description /Description / Beschreibung / Descrizione	Cantidad / Quantity / Quantité / Menge / Quantità	Medidas / Measurements / Dimensions /Maße / Misure	Material / Material / Matériau / Material / Materiale
A		800	10	Metal / Metal / Metal / Metall / Metallo
B		72	15	Latón / Brass / Latón / Messing / Ottone
C		100	ø0,15x150	Hilo crudo / Raw thread / Fil brut / Rohes Baumwollfaden / Filo crudo
D		68	4	Madera / Wood / Bois / Holz / Legno
E		32	4	Madera / Wood / Bois / Holz / Legno
F		24	4	Madera / Wood / Bois / Holz / Legno
F		72	5	Madera / Wood / Bois / Holz / Legno
H		56	ø3	Latón / Brass / Latón / Messing / Ottone
J		59	10	Madera / Wood / Bois / Holz / Legno
K		3	3	Cristal / Glass / Verre / Glas / Vetro



Accede a vídeos tutoriales fotografiando los códigos QR.
Access tutorial videos photographing QR codes.
Accédez aux didacticiels vidéo photographiant les codes QR.
Greifen Sie auf Video-Tutorials zu, die QR-Code fotografieren.
Accedi ai video tutorial fotografando i codici QR.
Доступ к видеоурокам фотографирования QR-кодов.

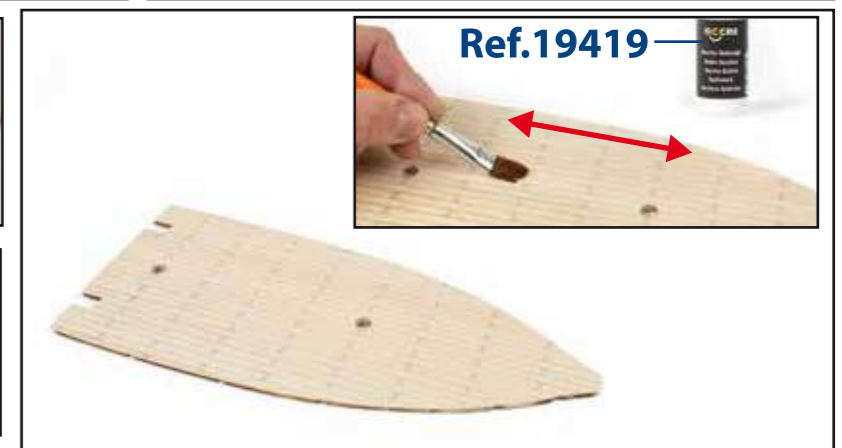
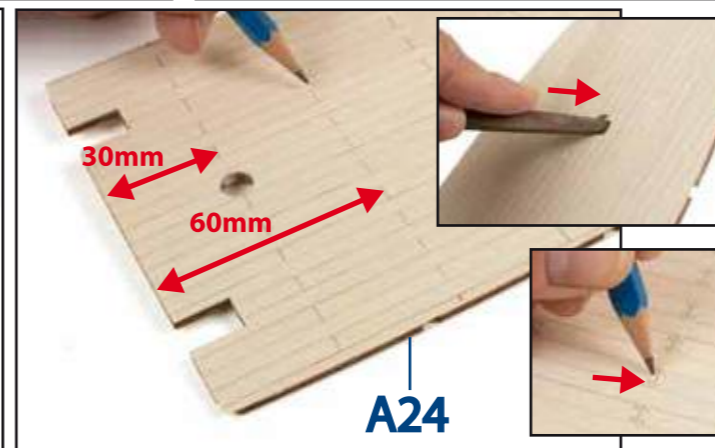
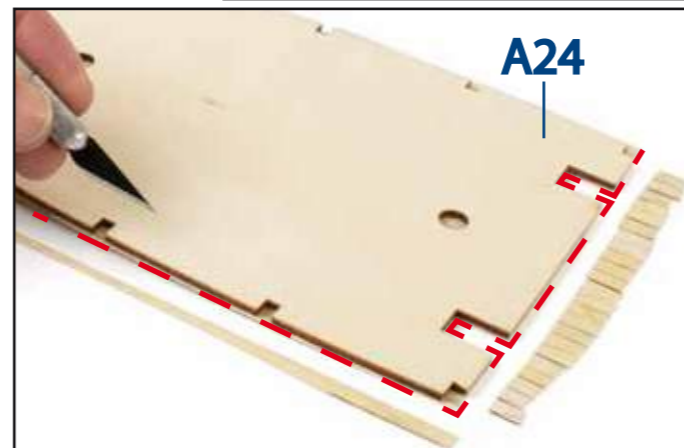
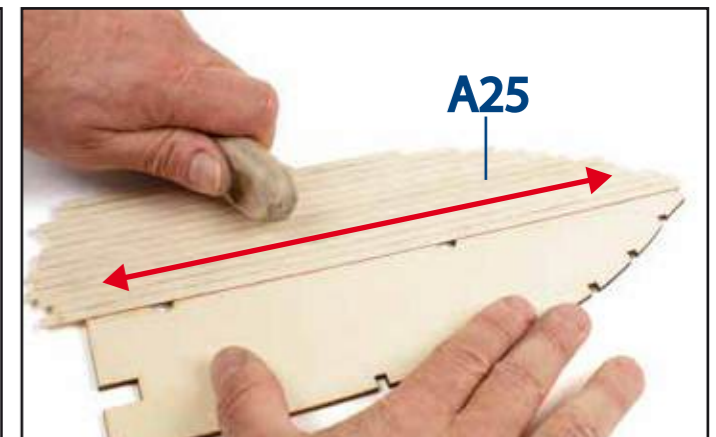
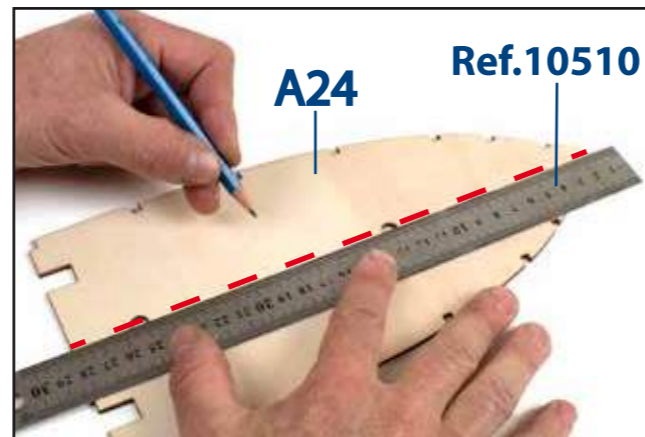
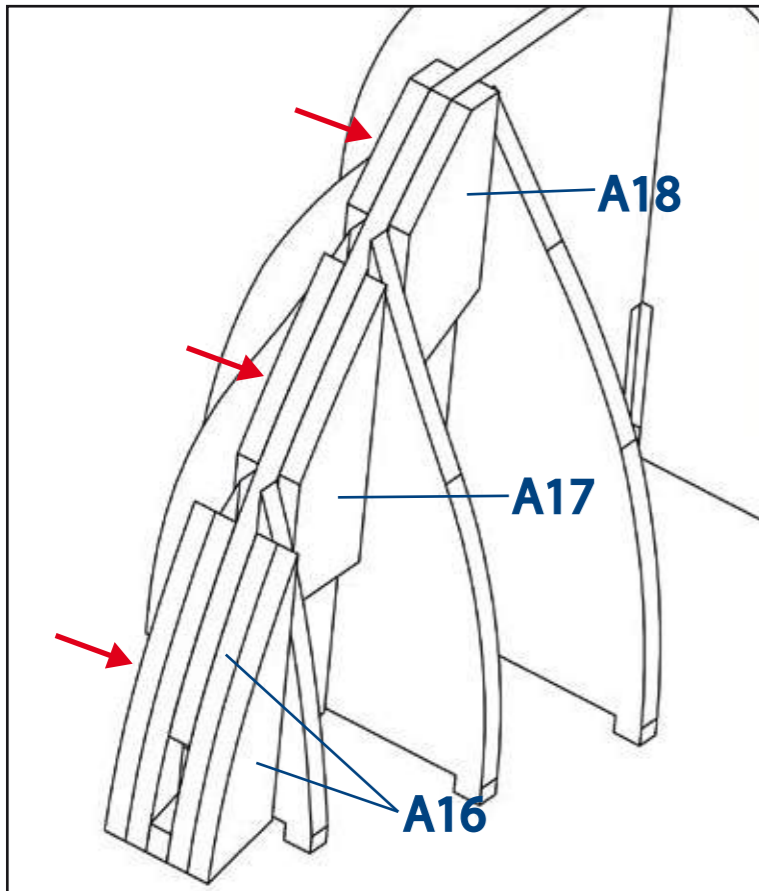
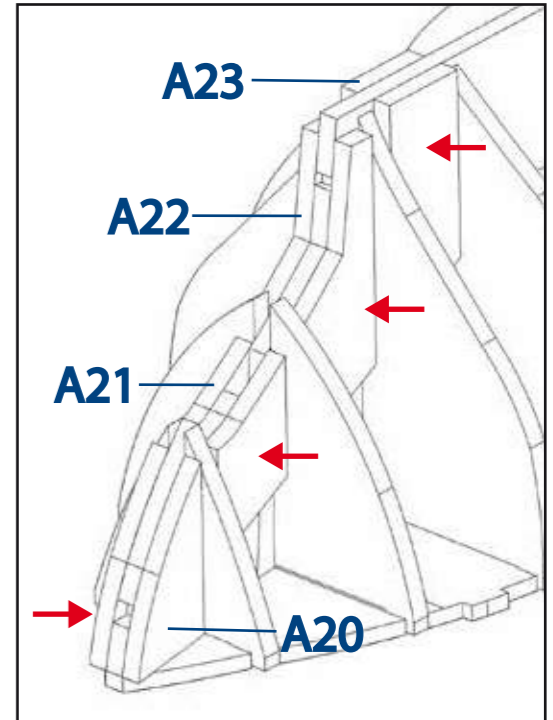
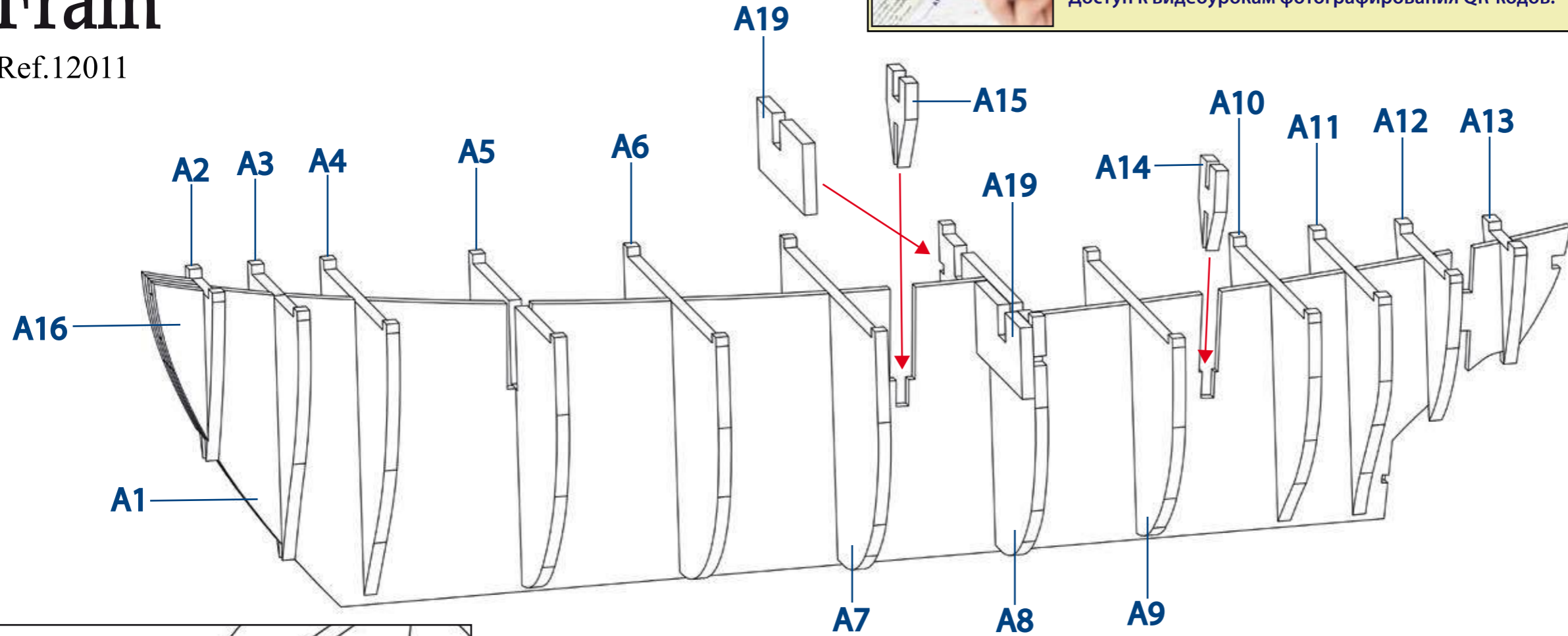

B

Ref.19418
Ref.19412

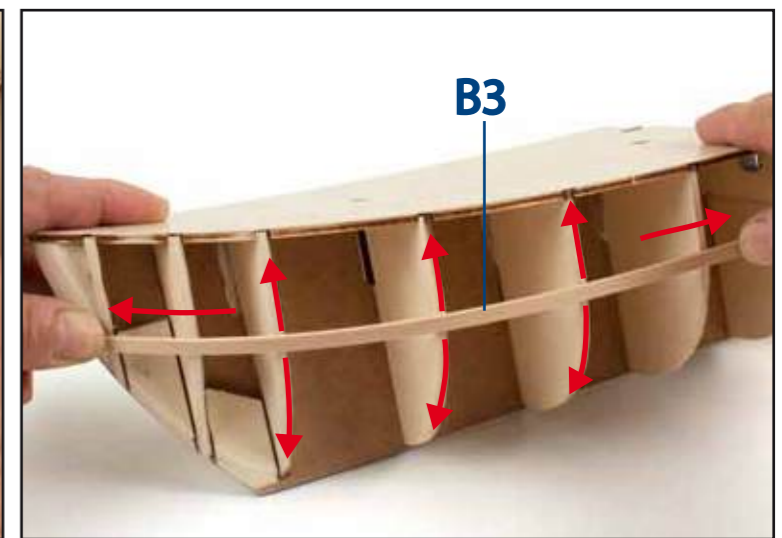
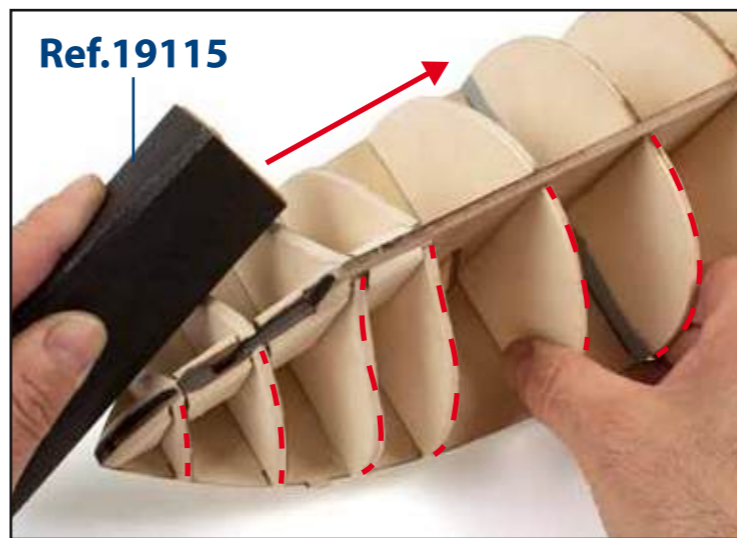
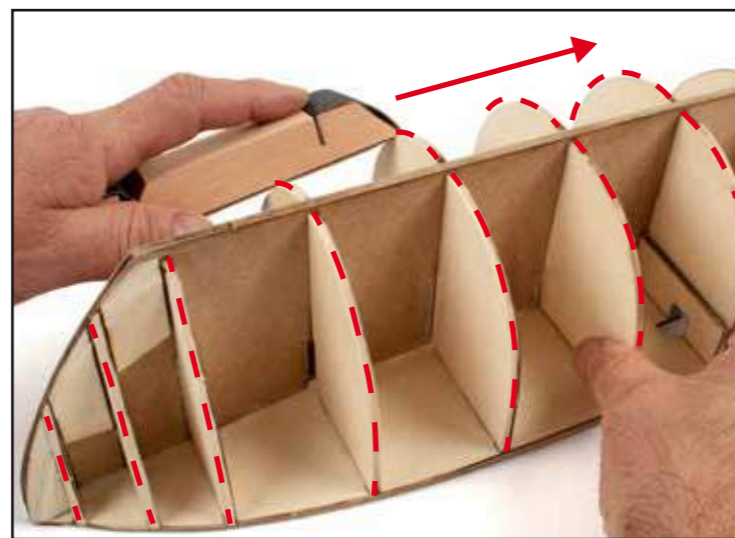
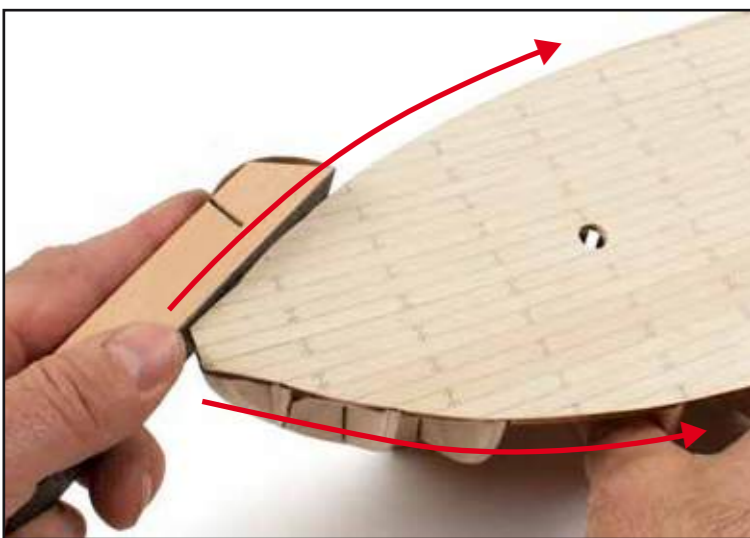
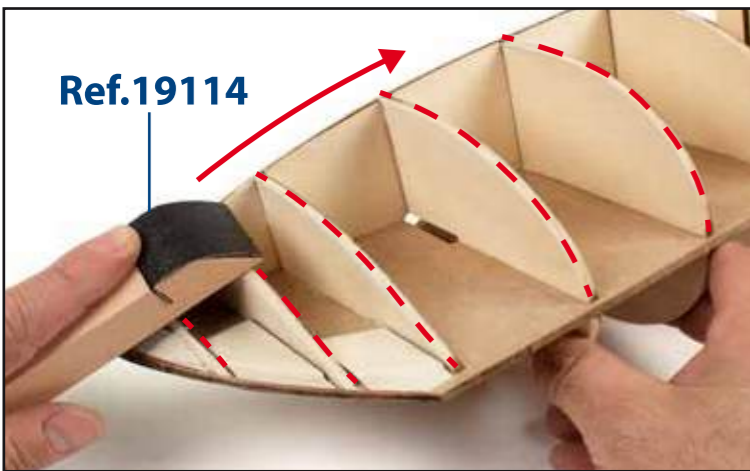
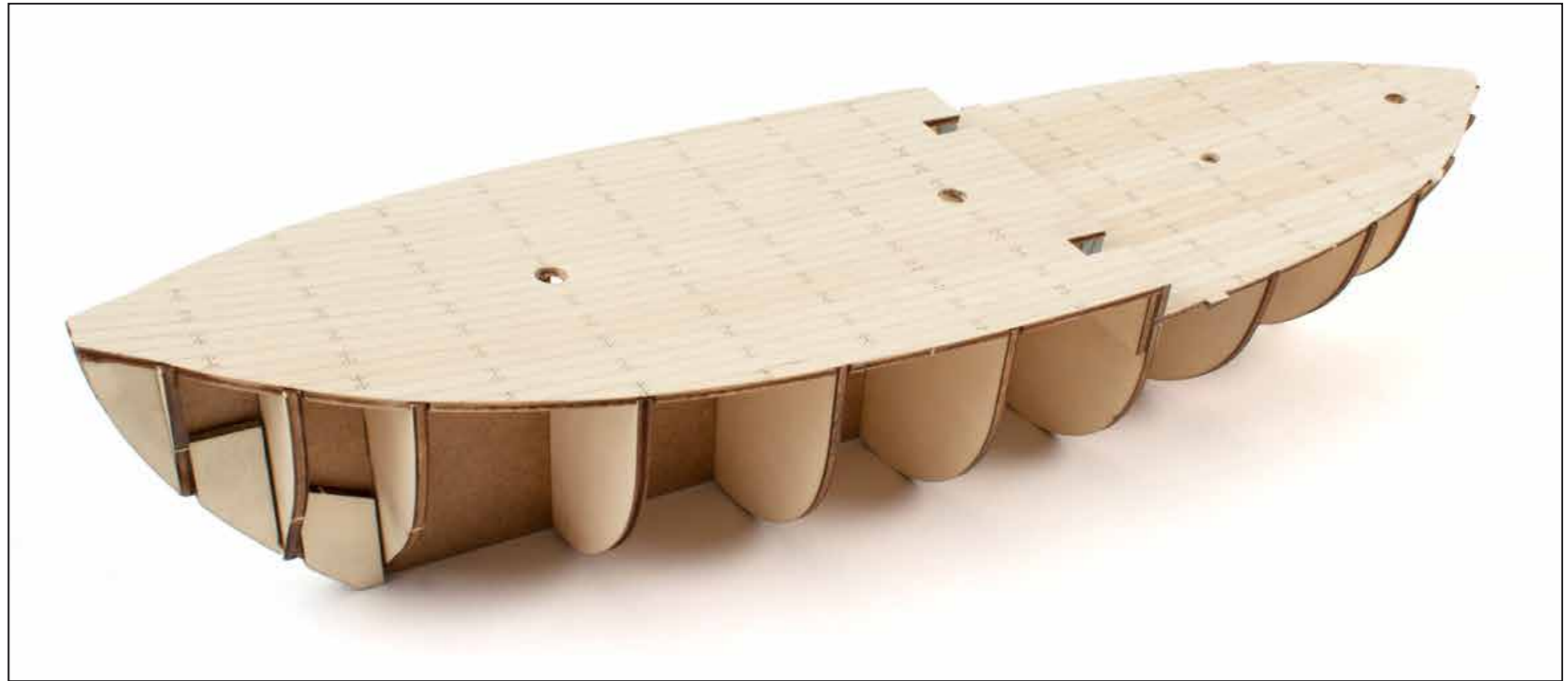
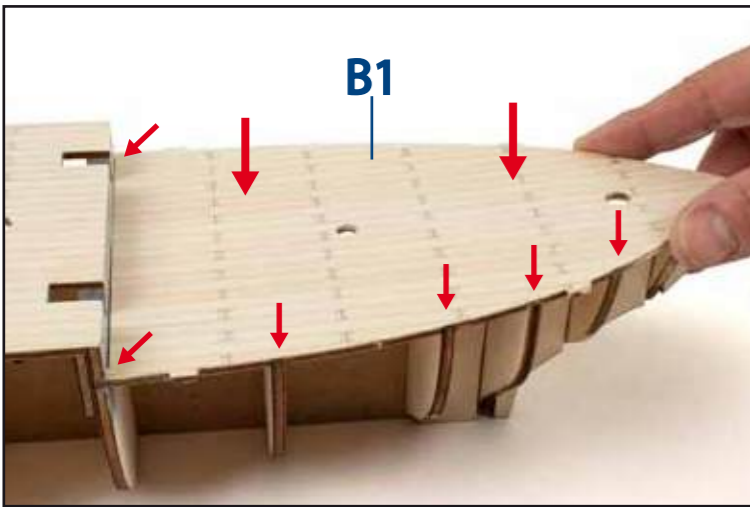
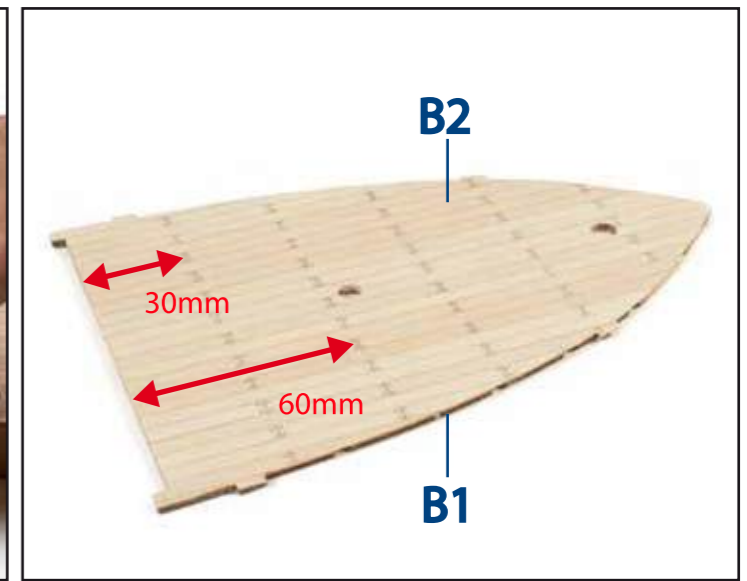
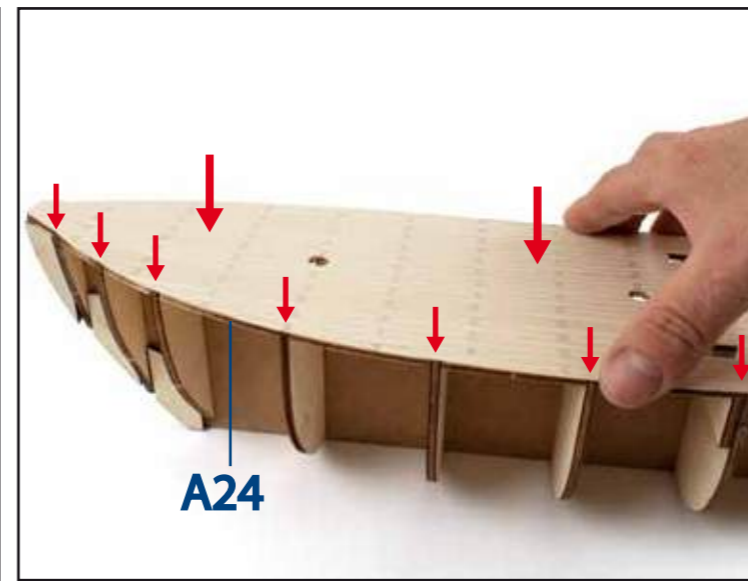
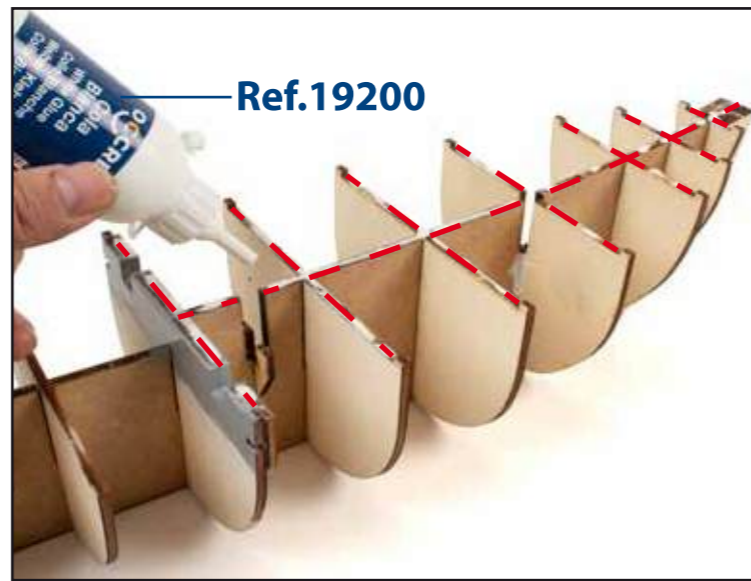
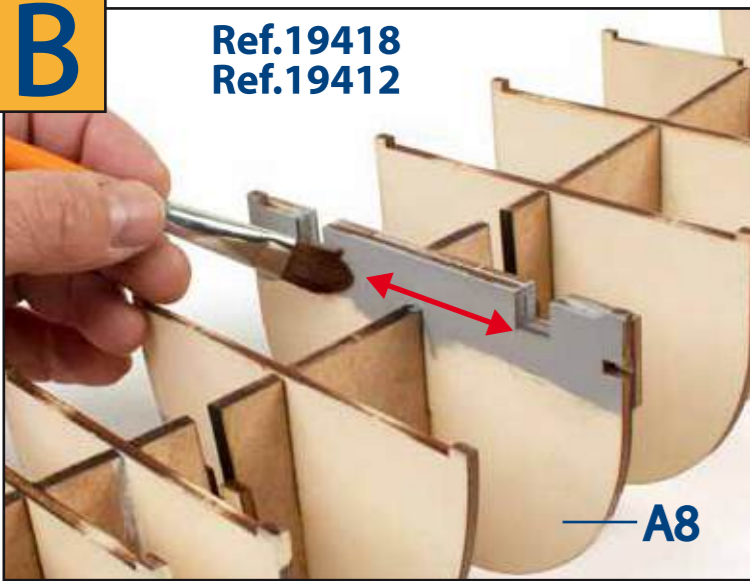

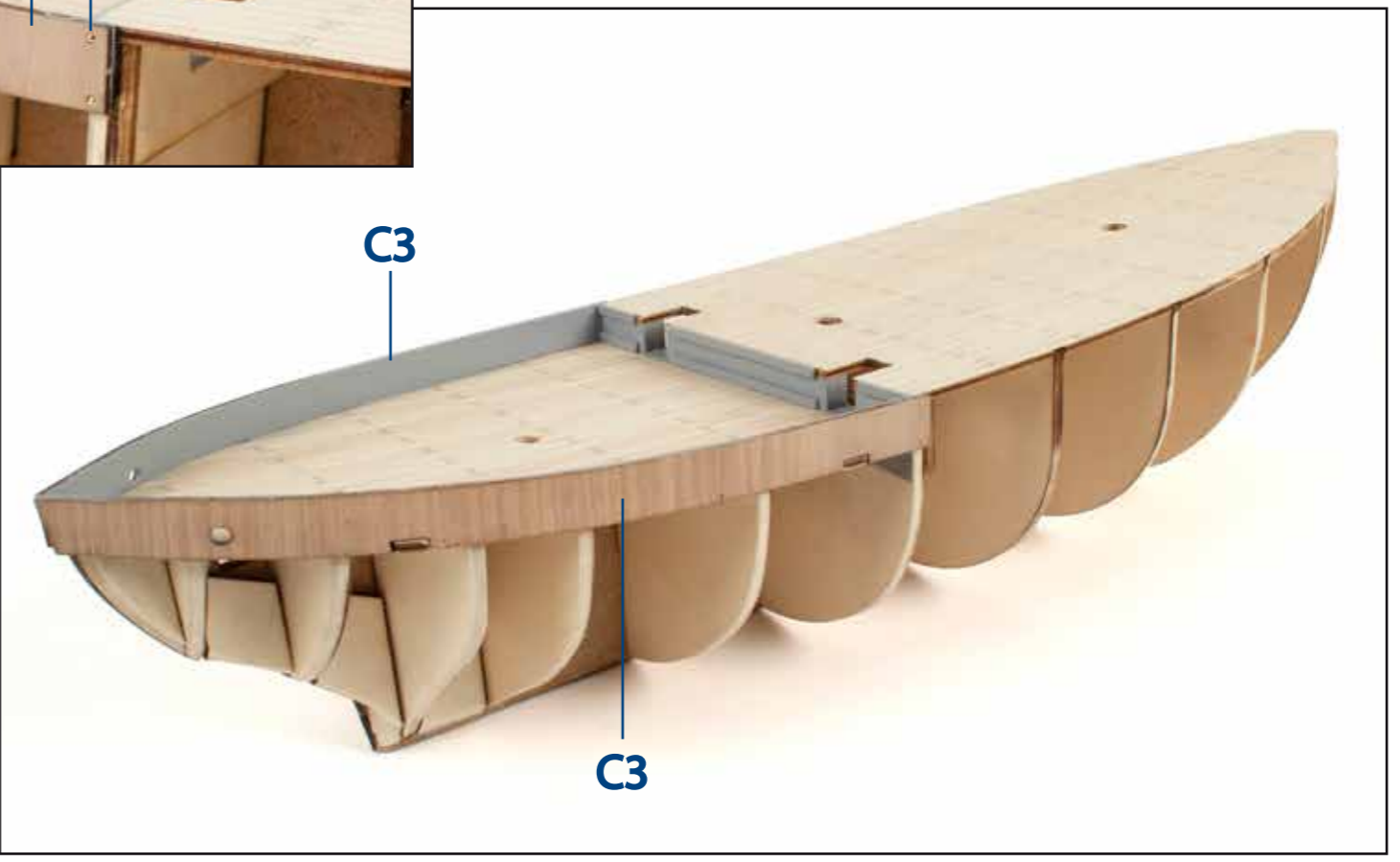
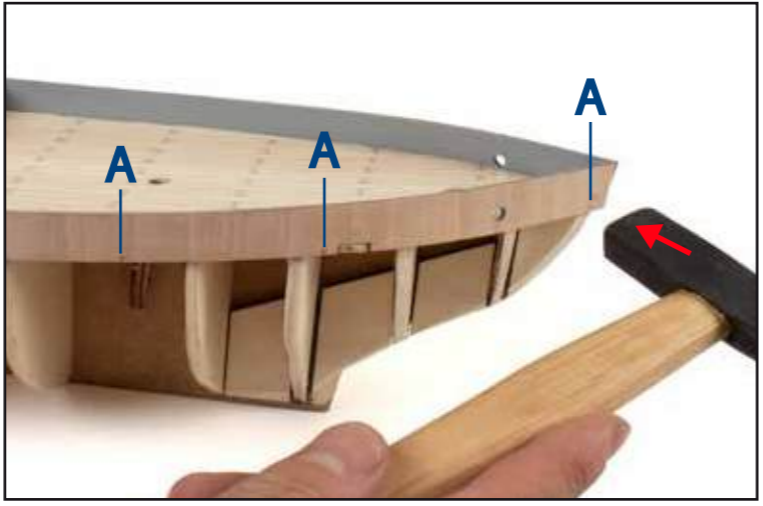
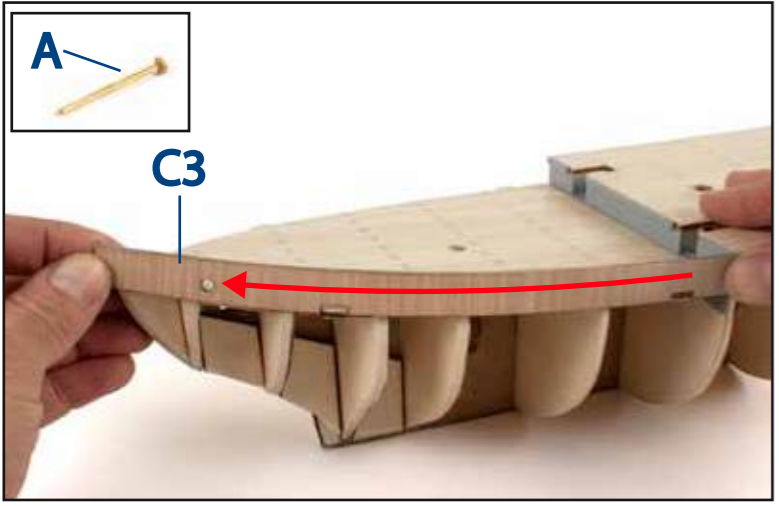
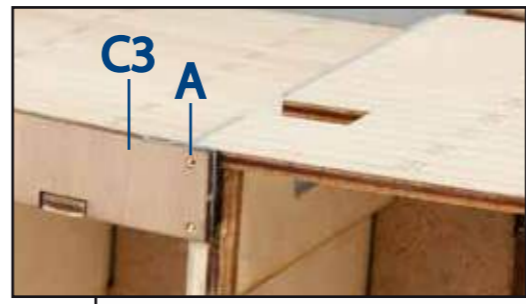
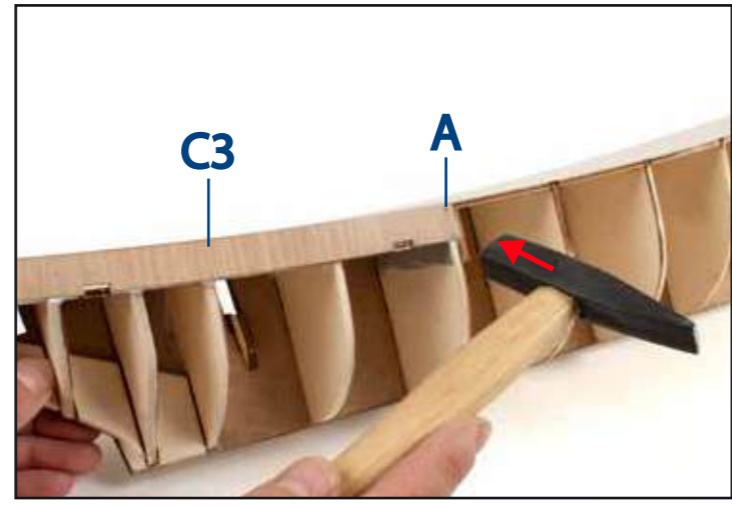
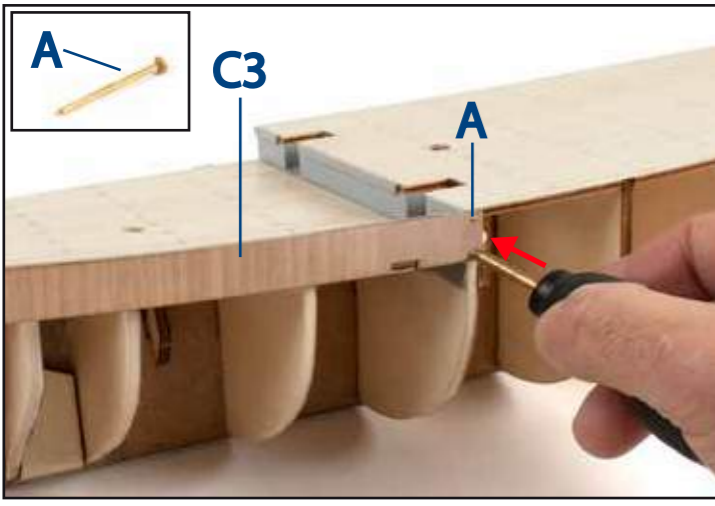
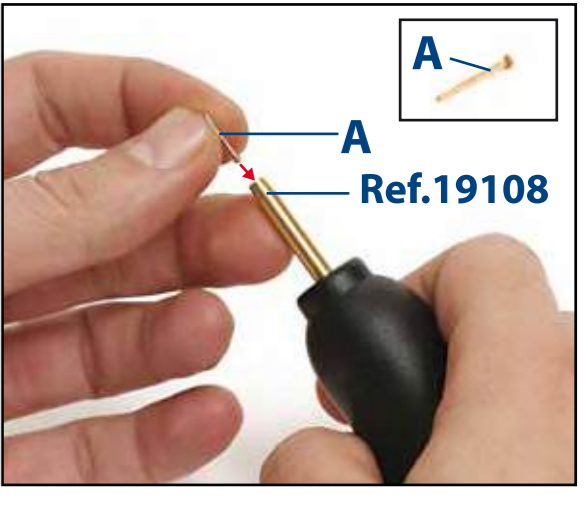
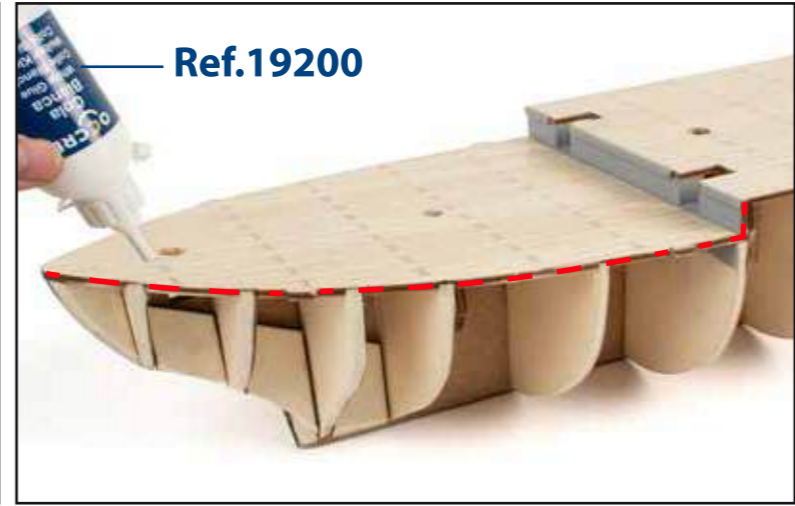
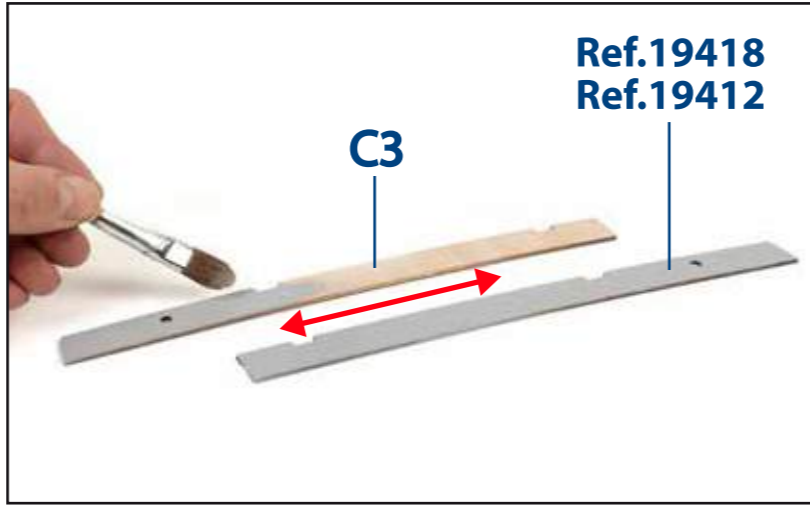
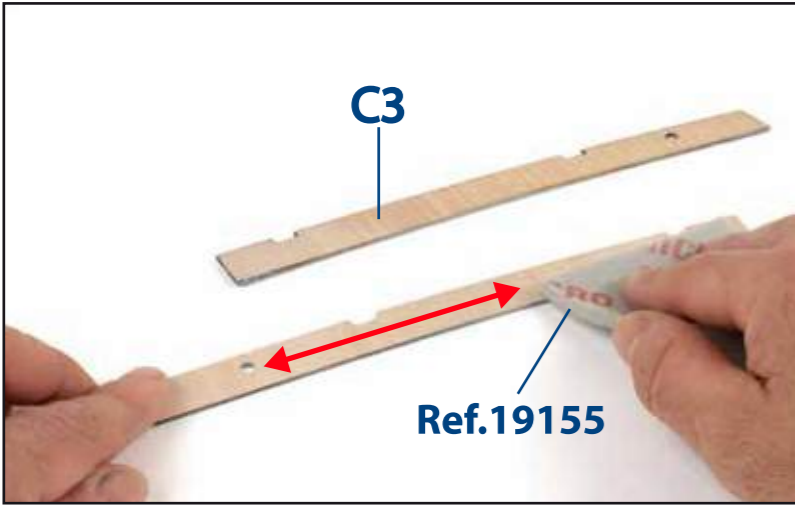
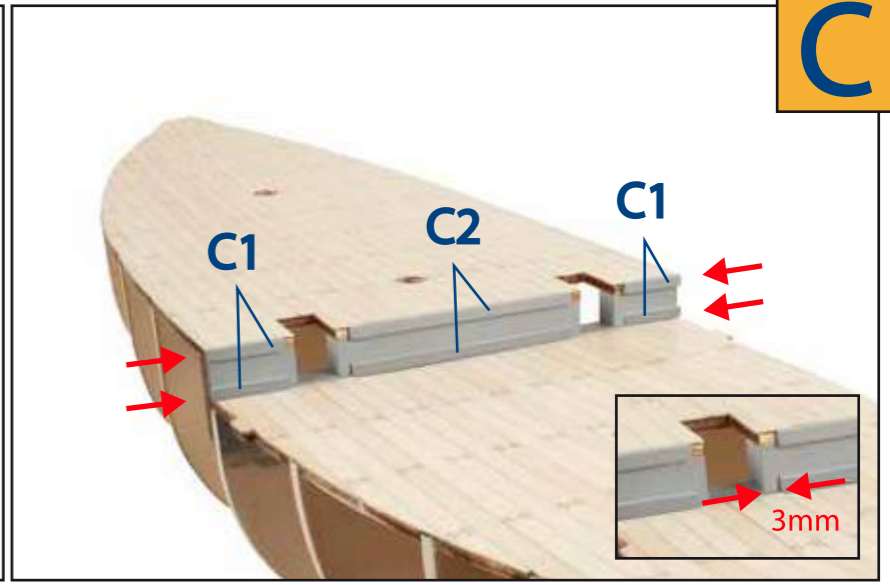
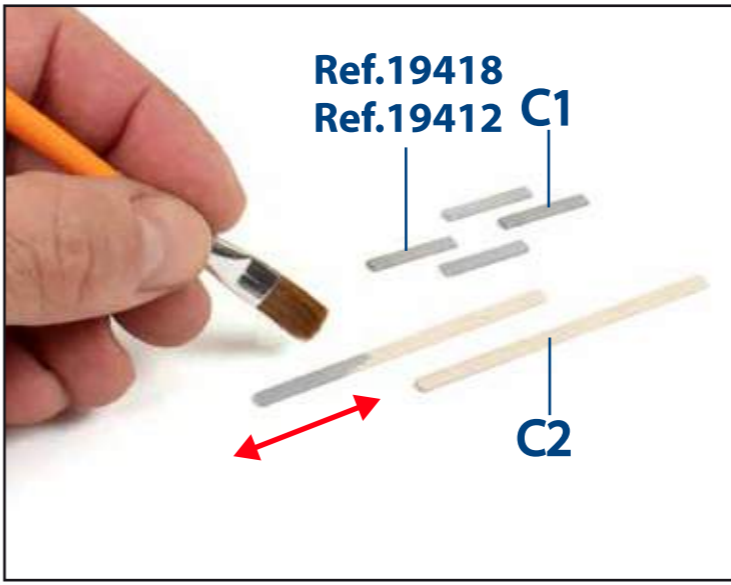
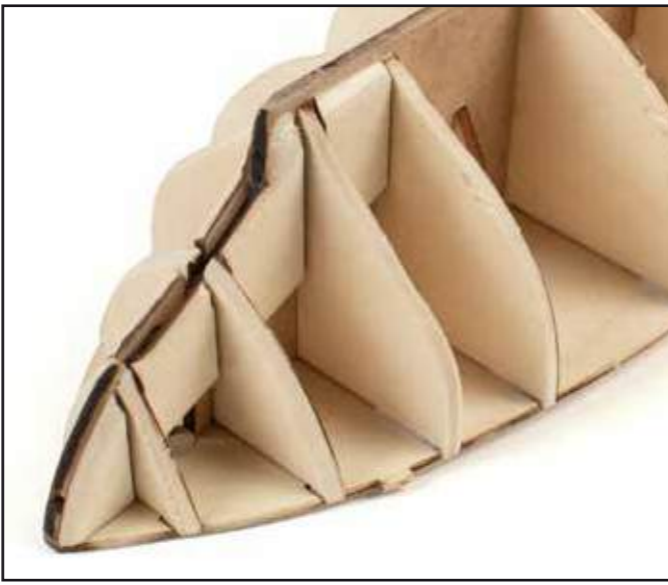

D

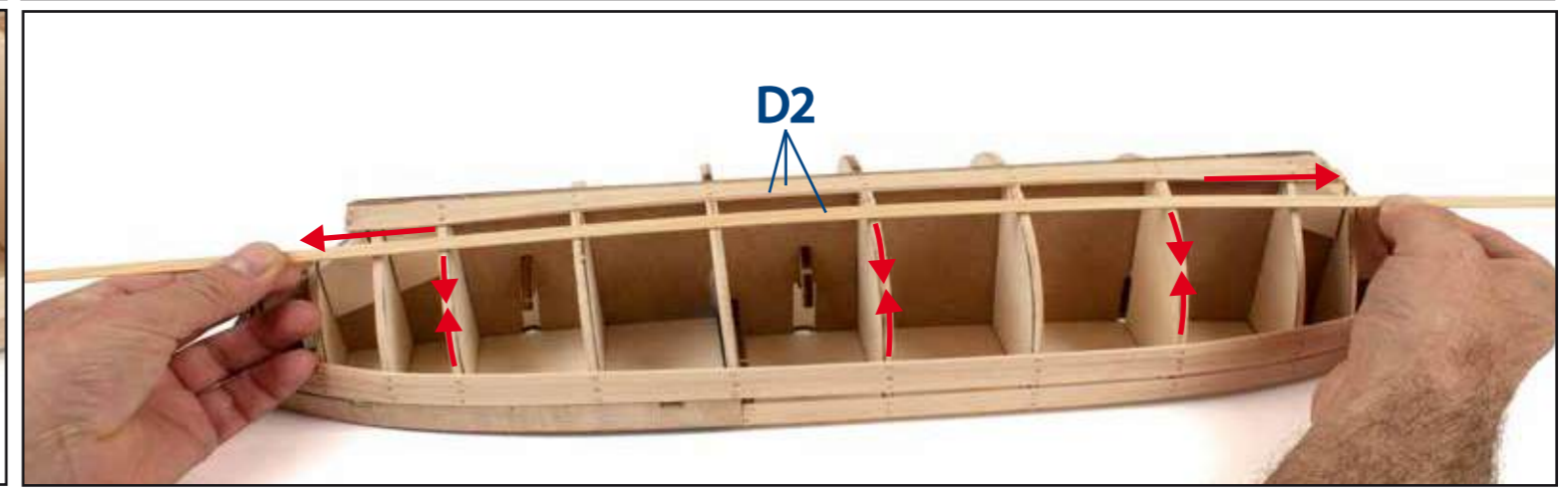
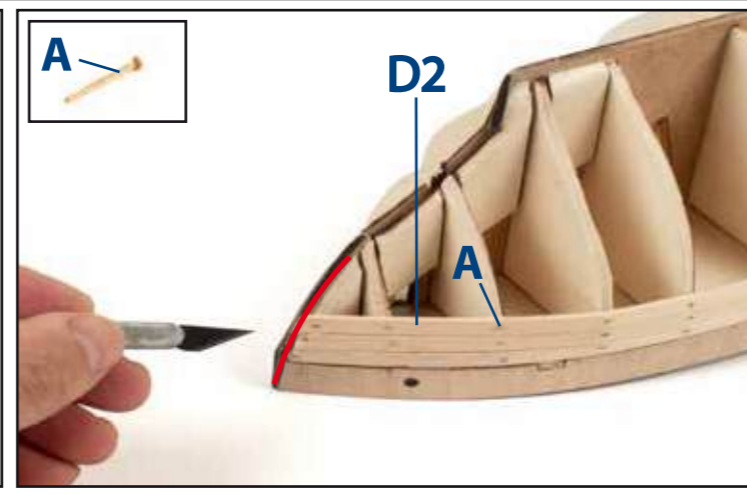
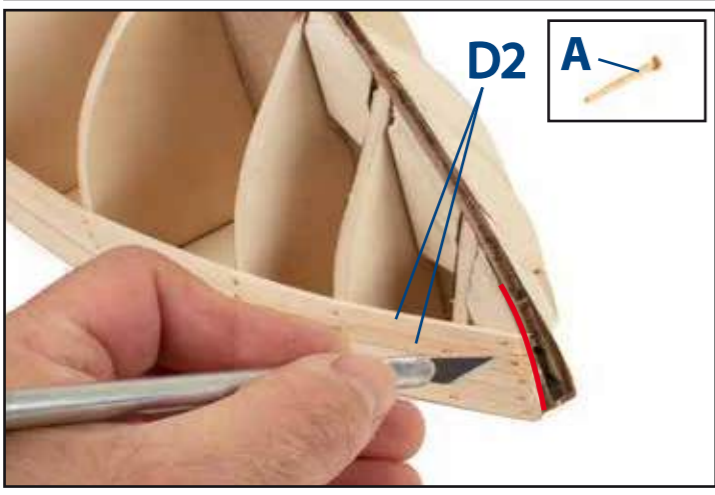
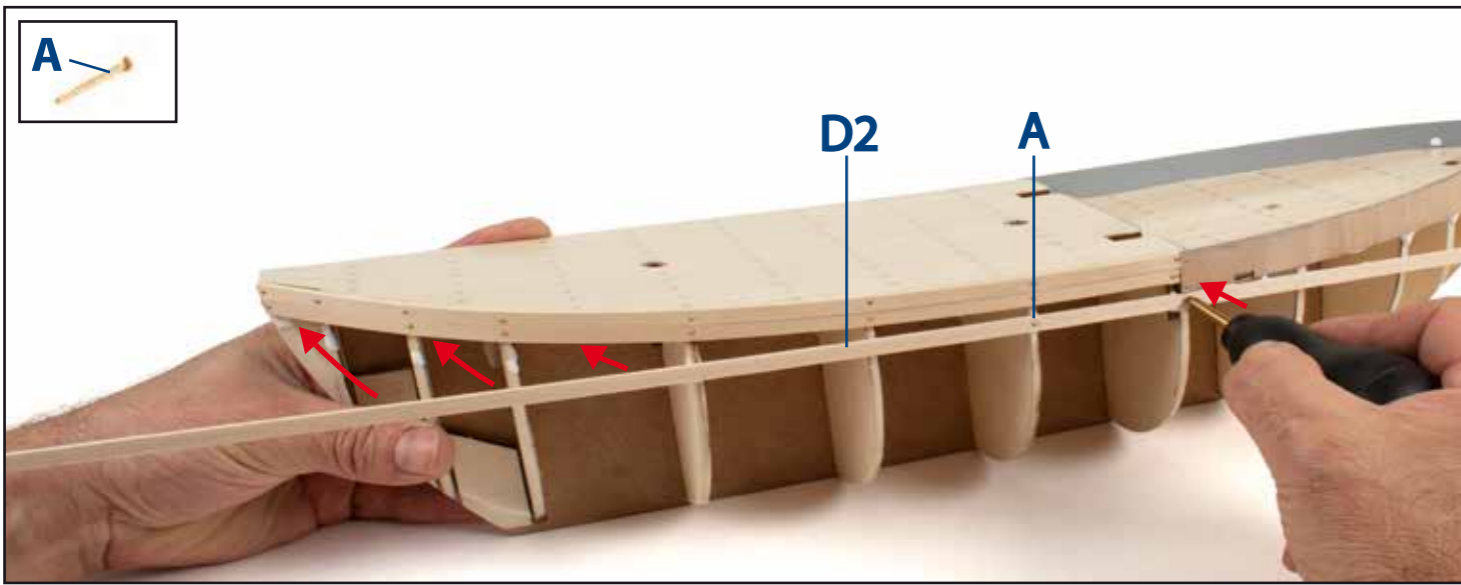
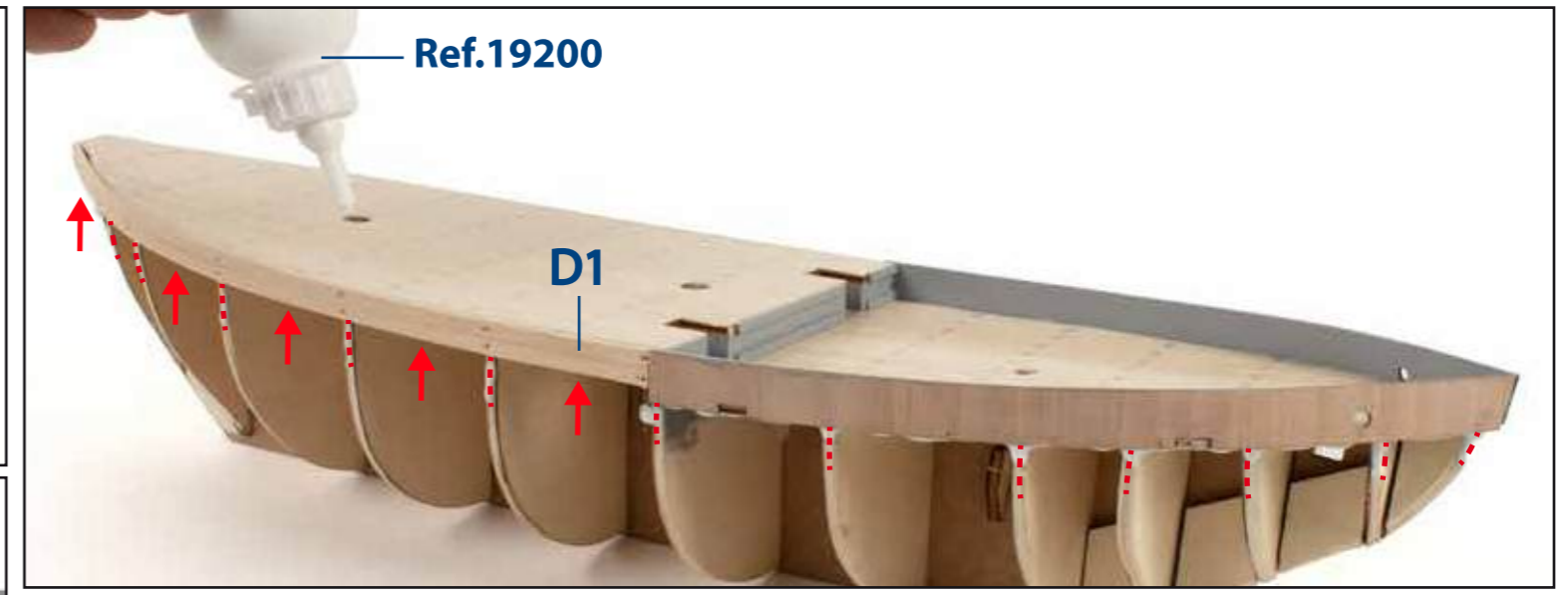
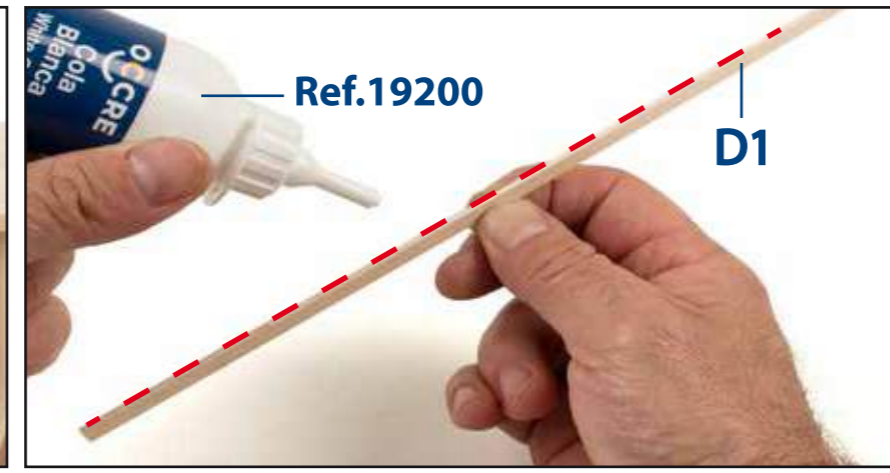
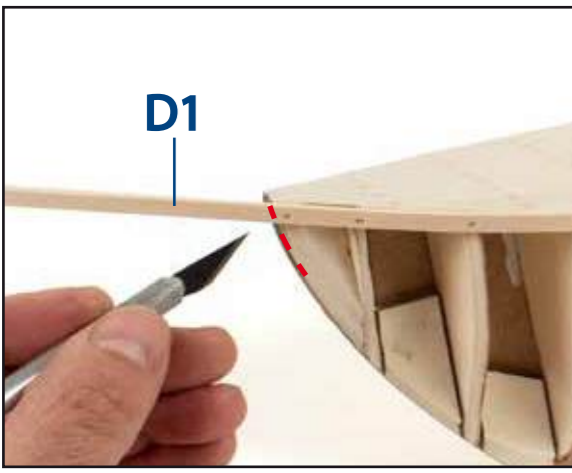
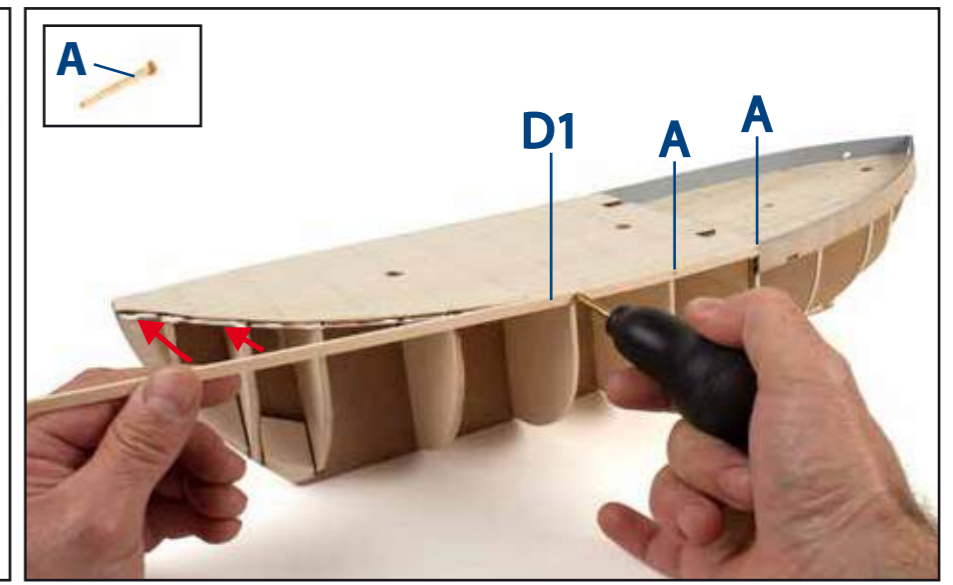
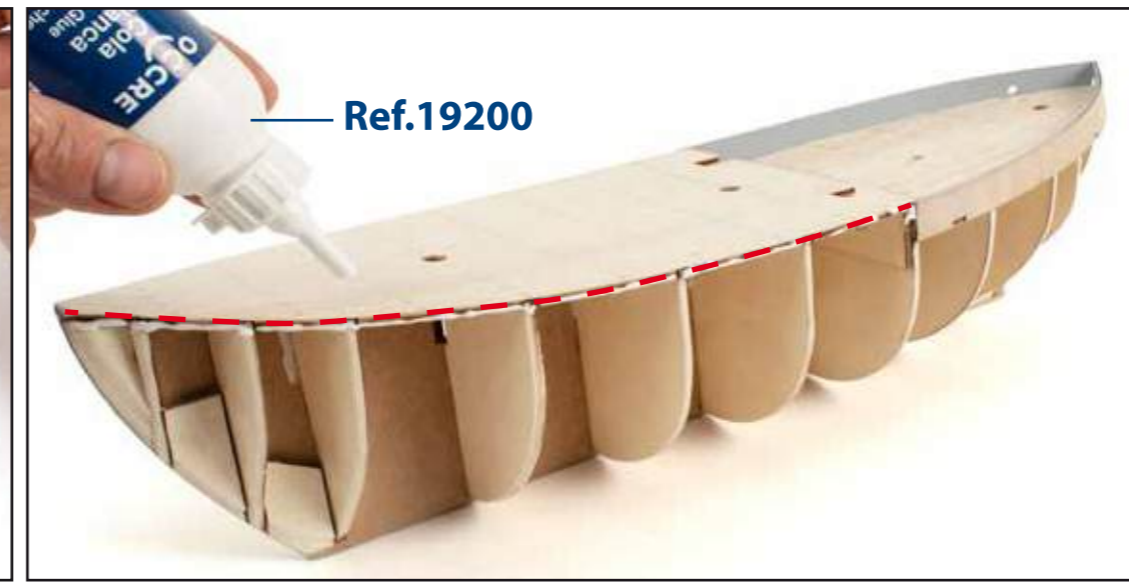
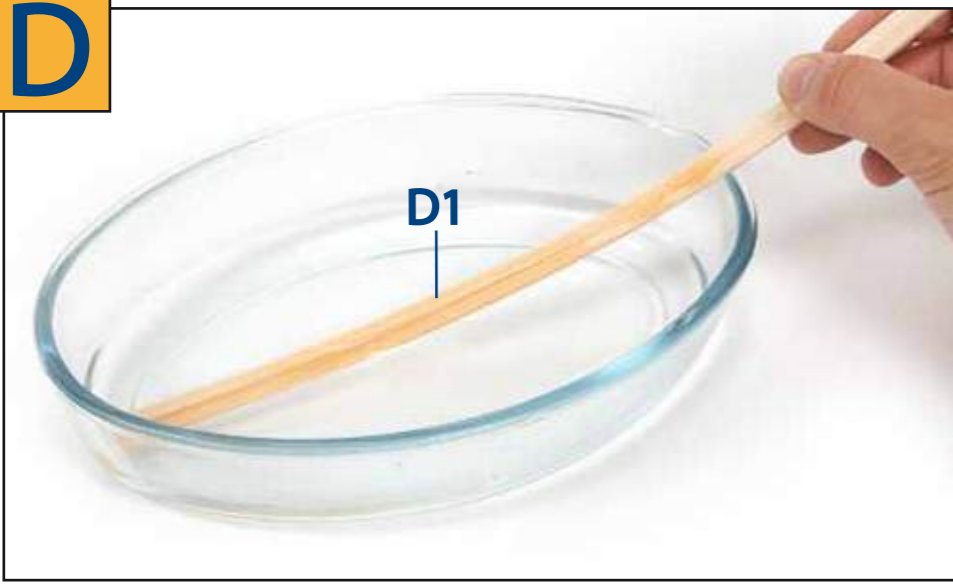

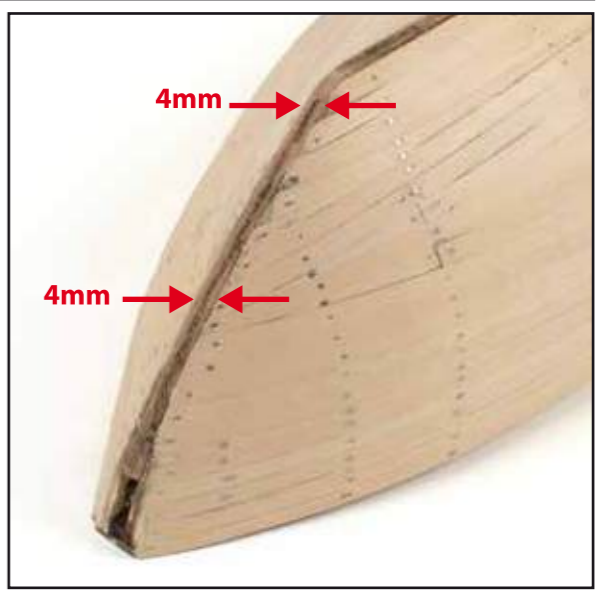
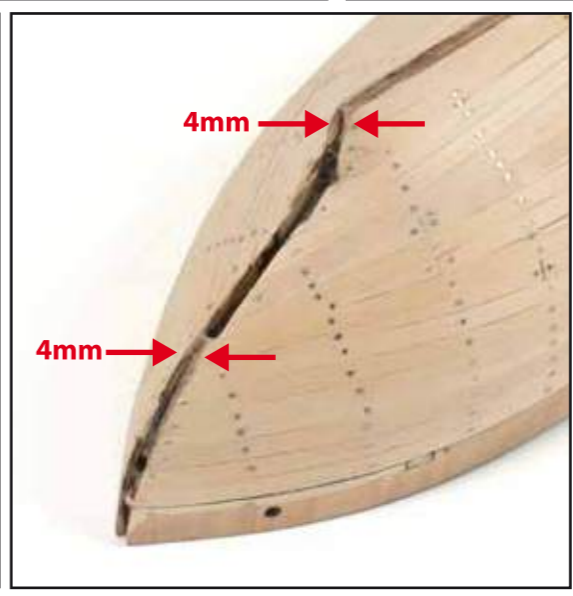
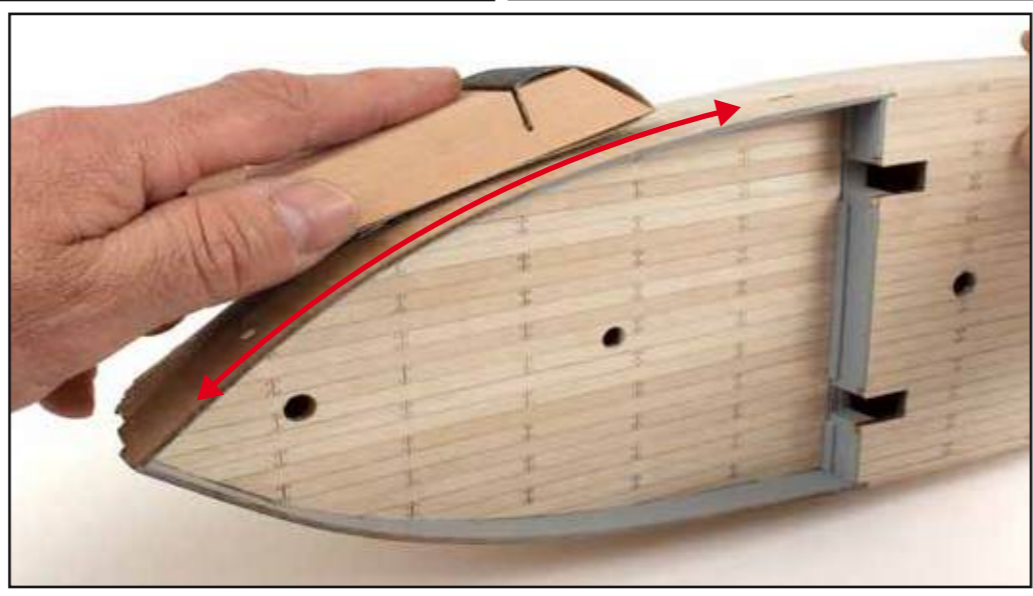
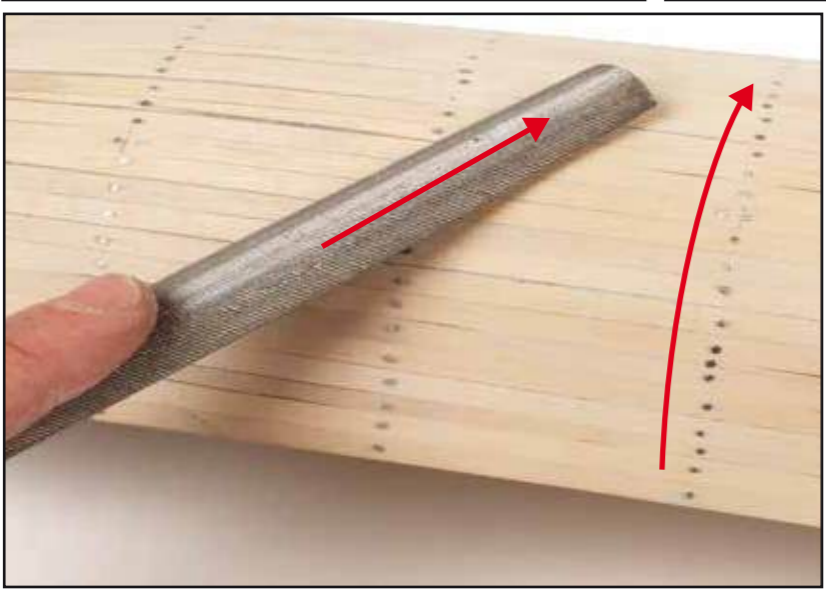
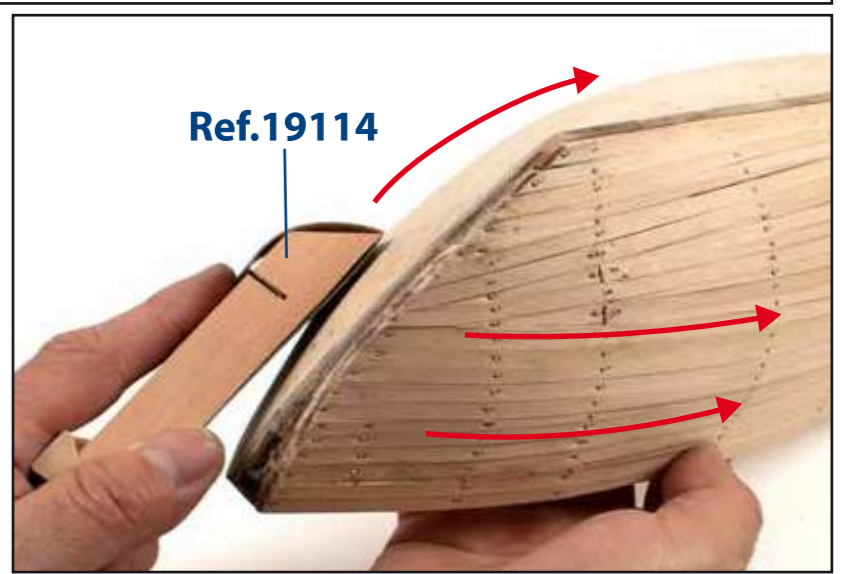
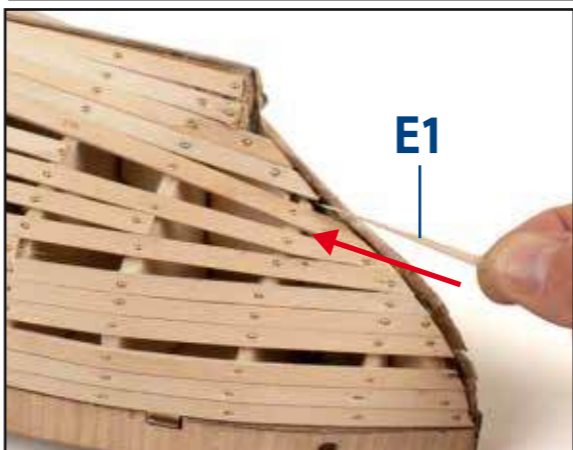
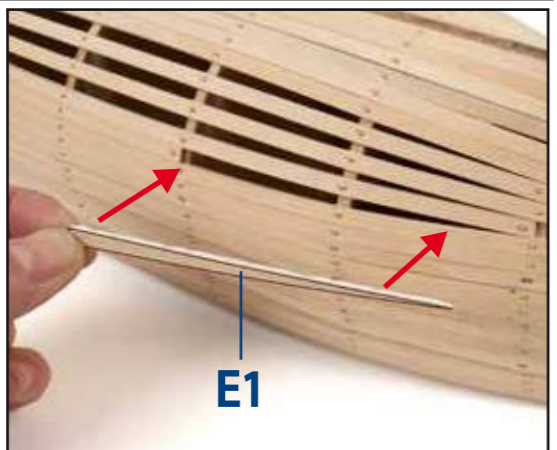
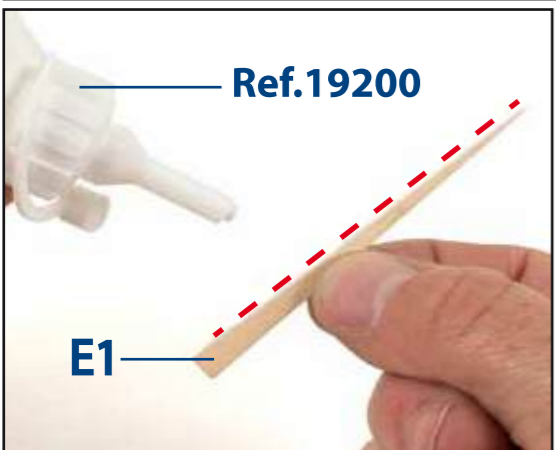
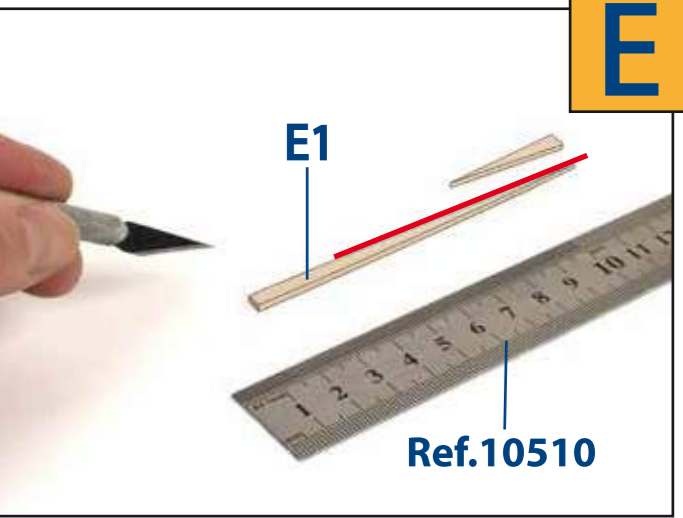
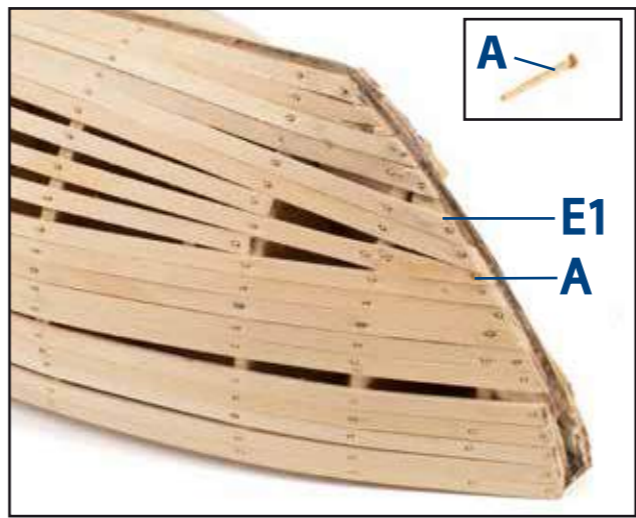
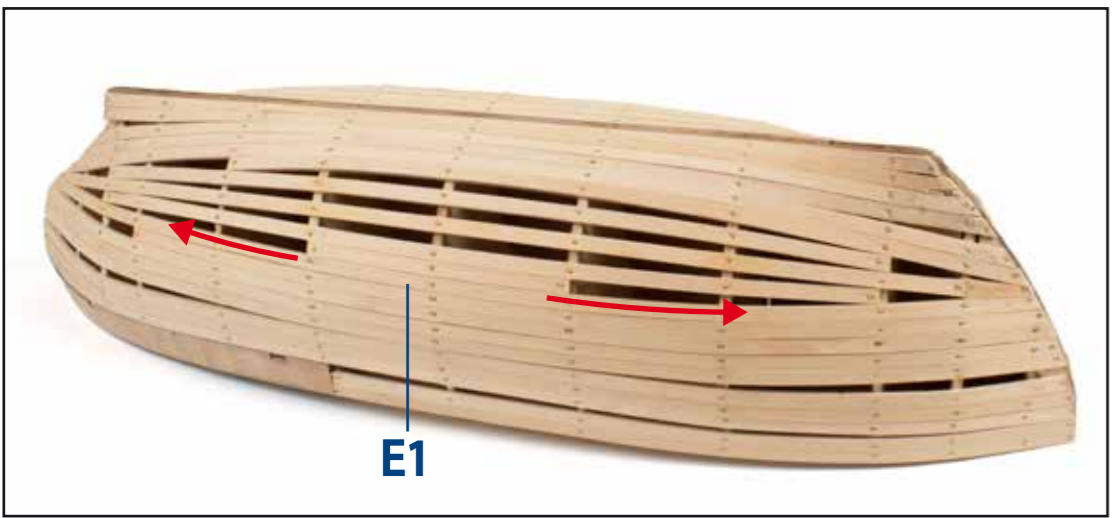

F

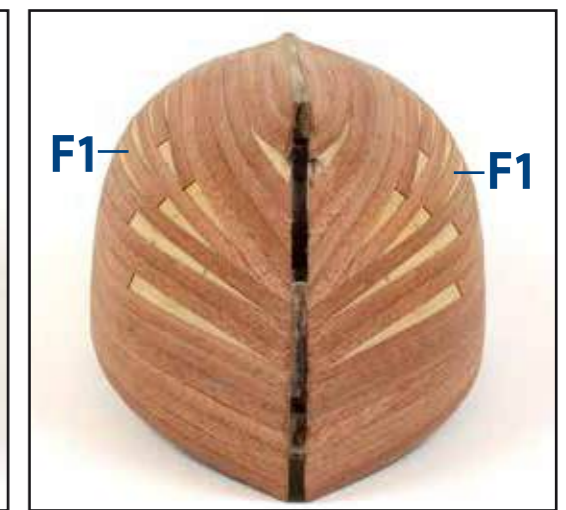
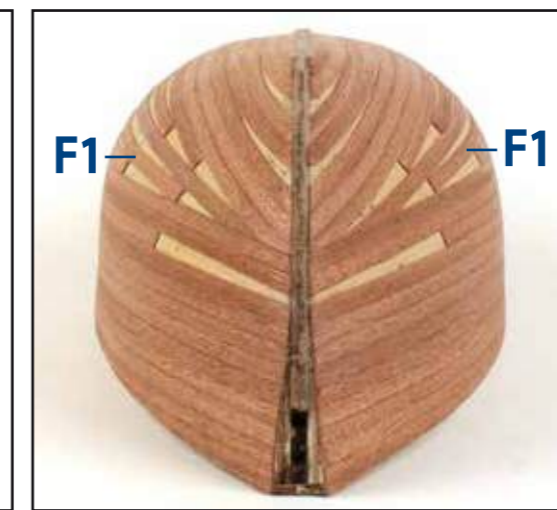
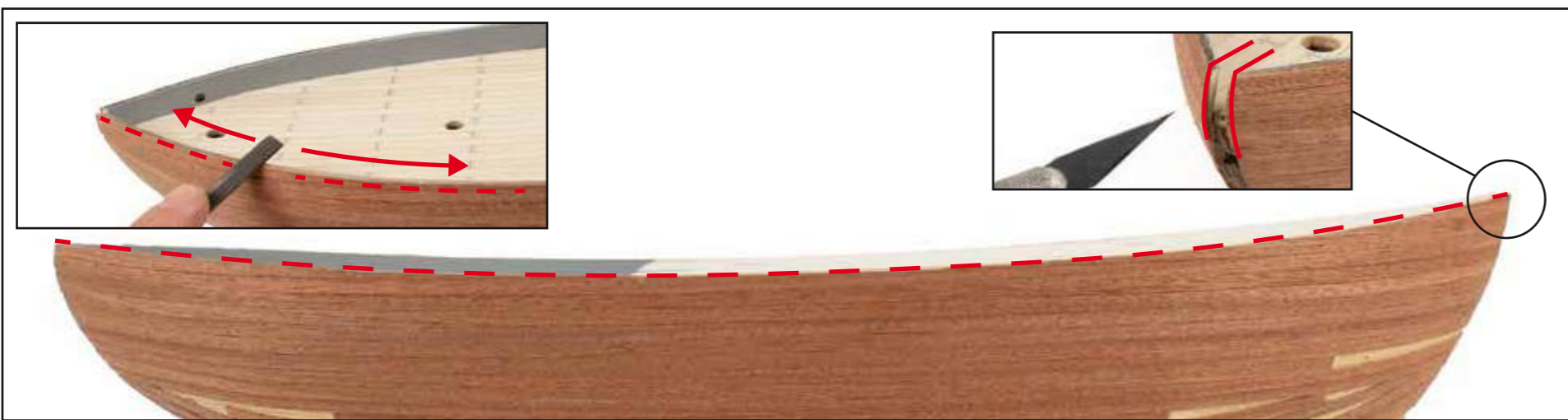
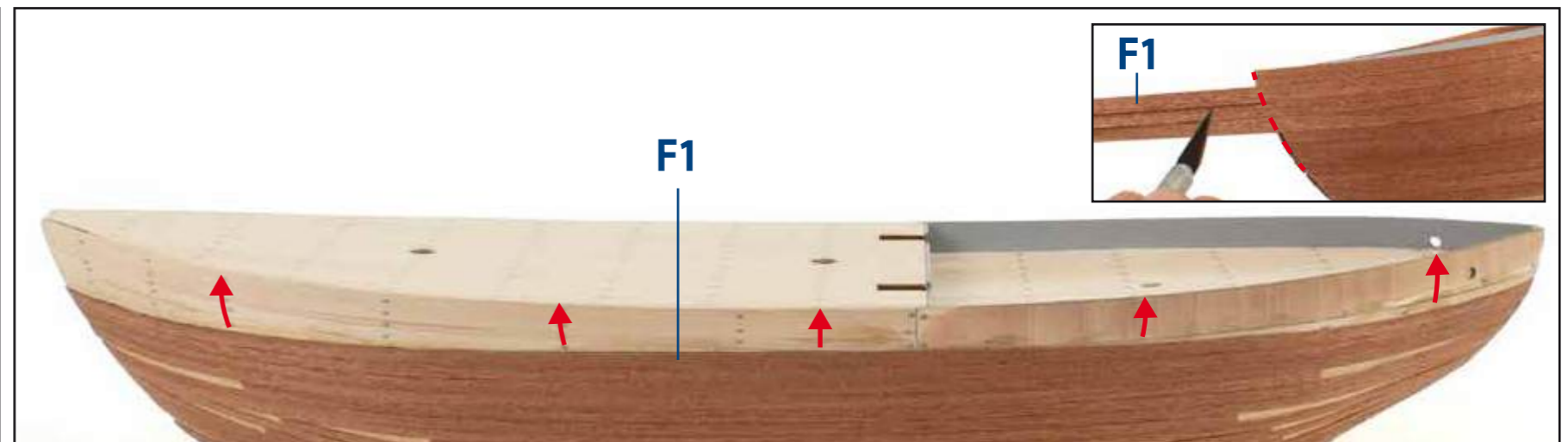
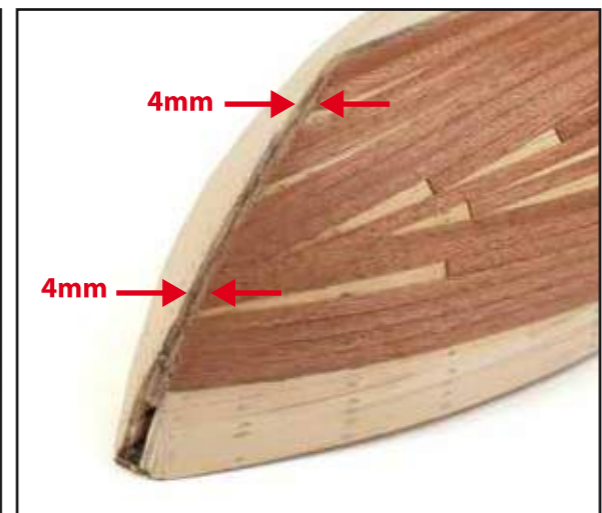
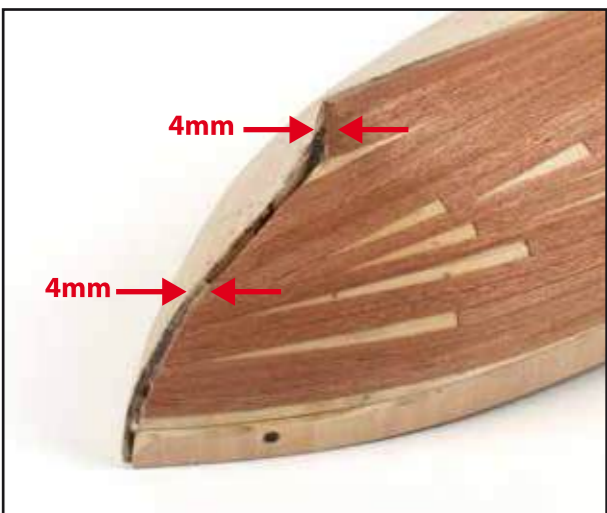
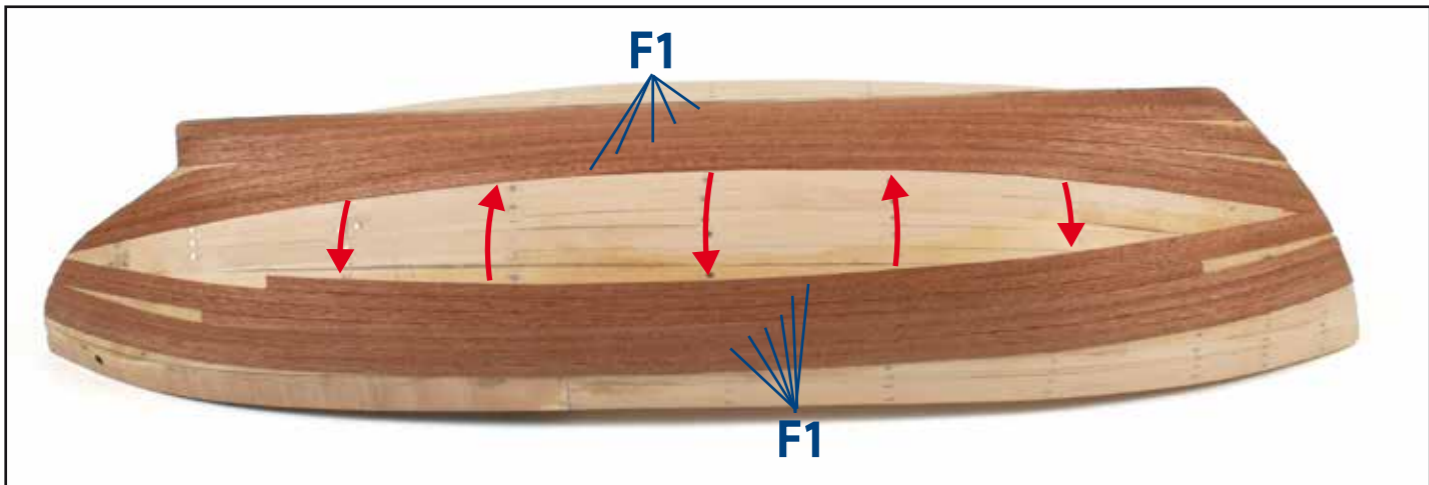
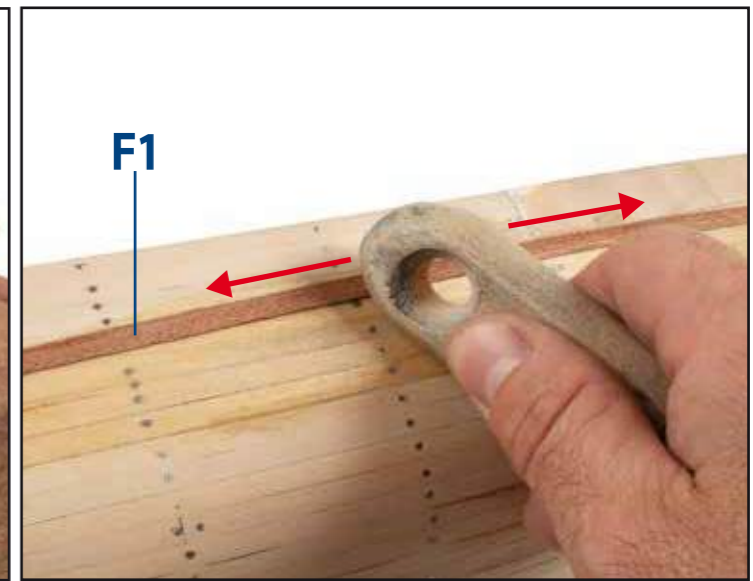
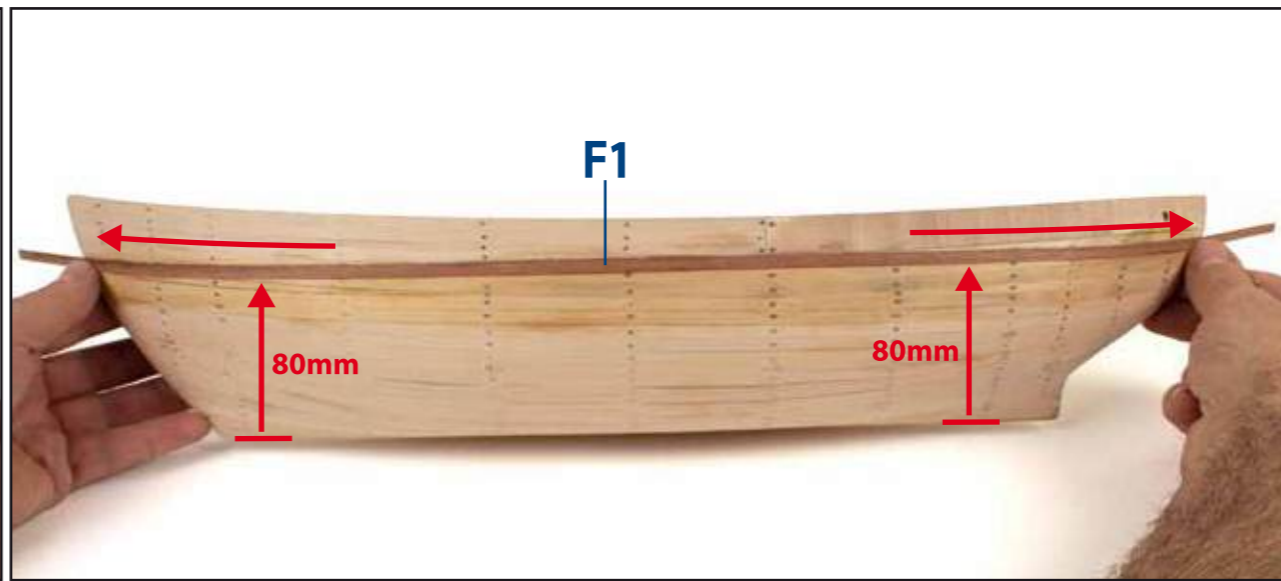
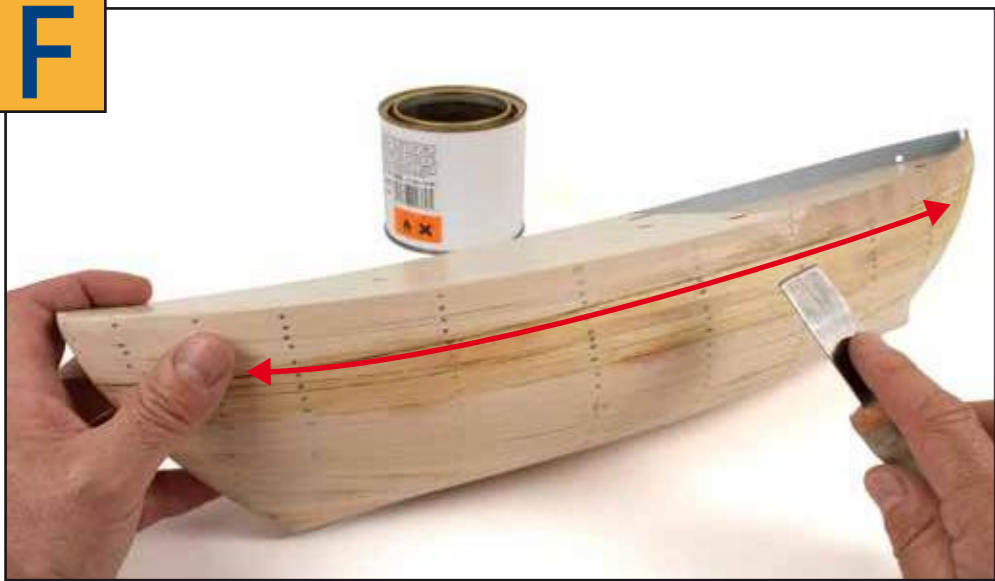

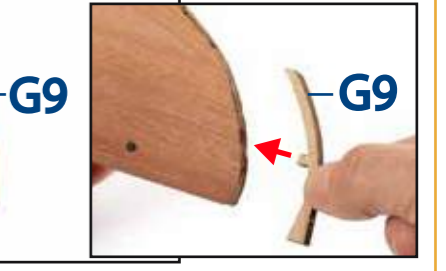
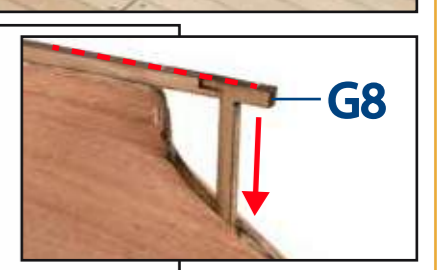
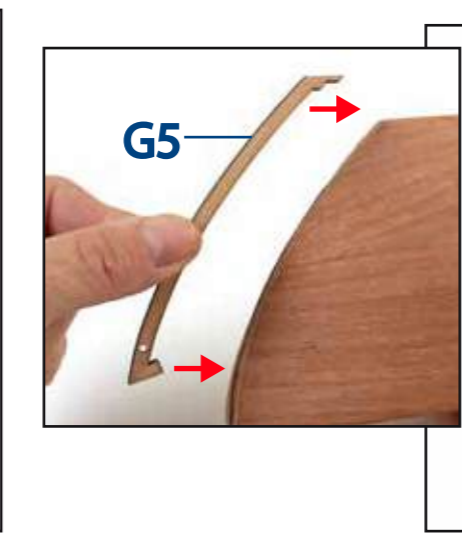
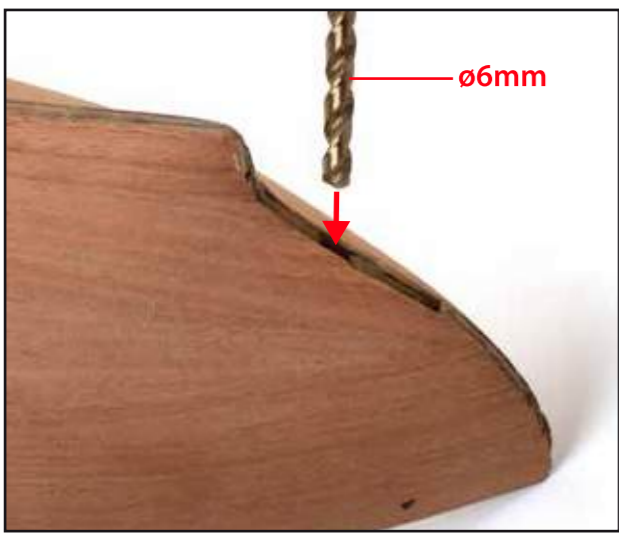
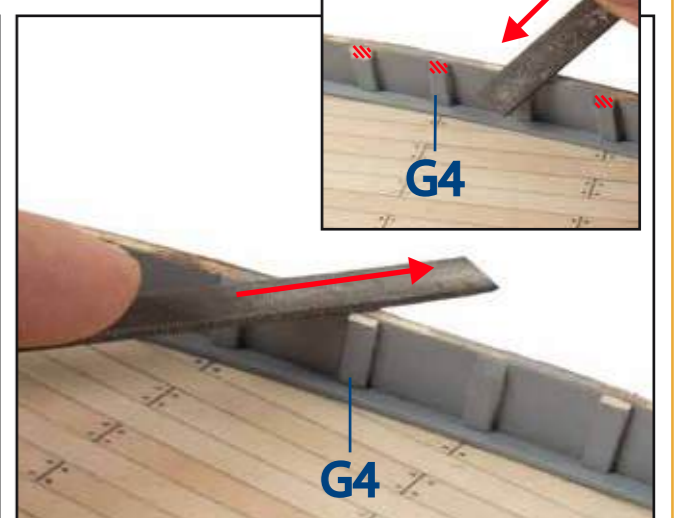
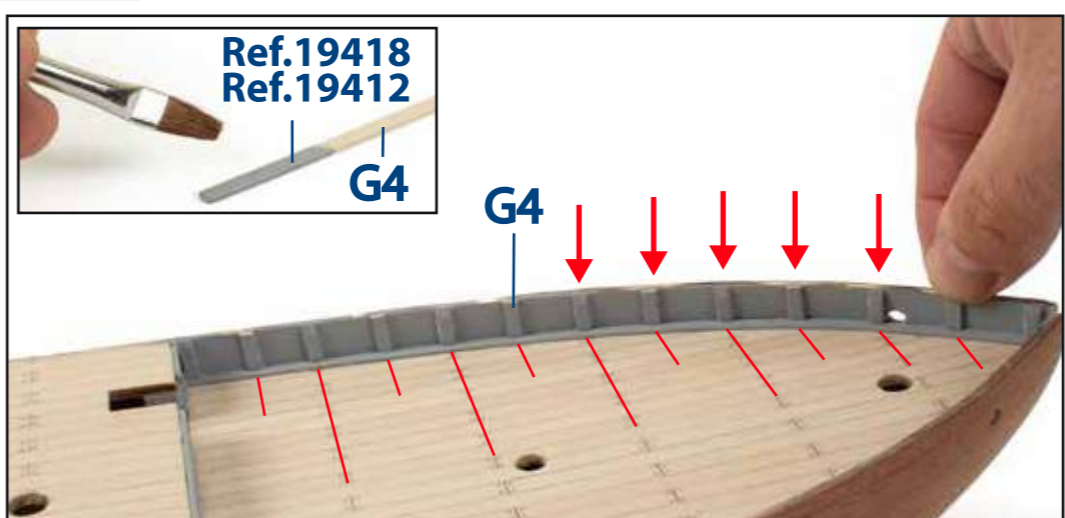
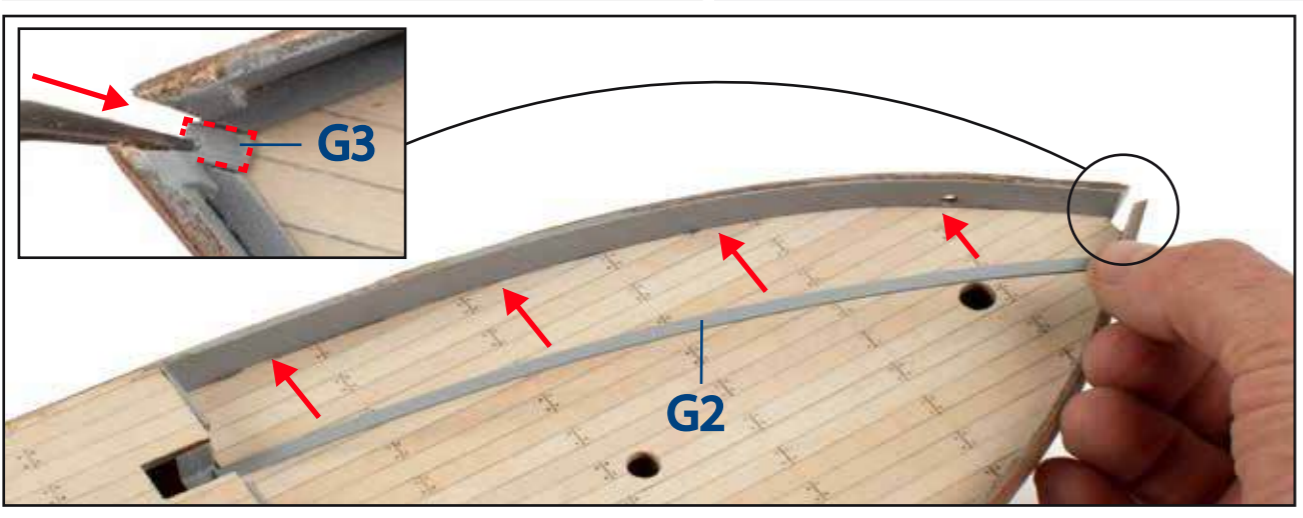
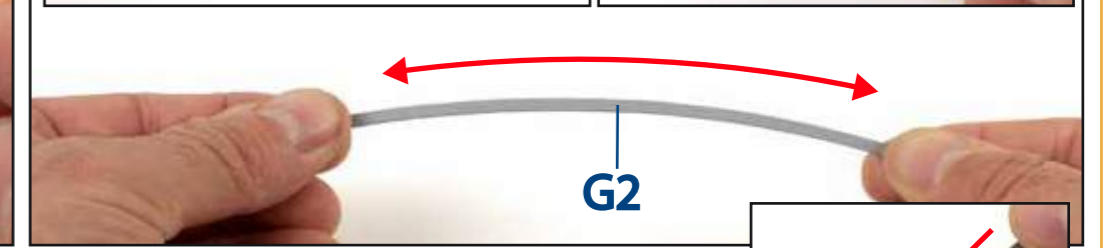
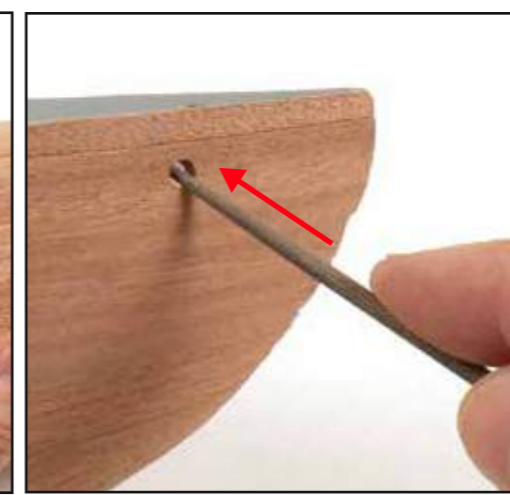
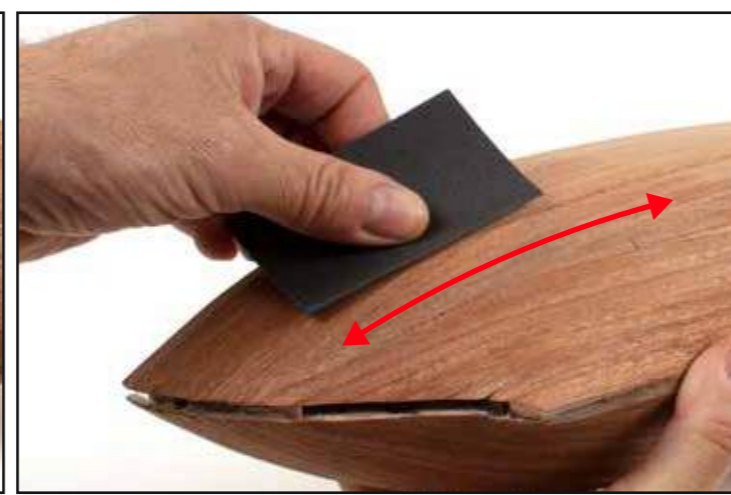
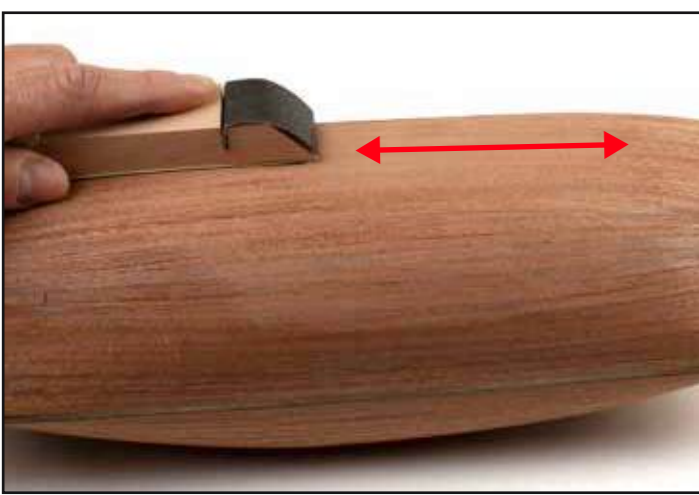
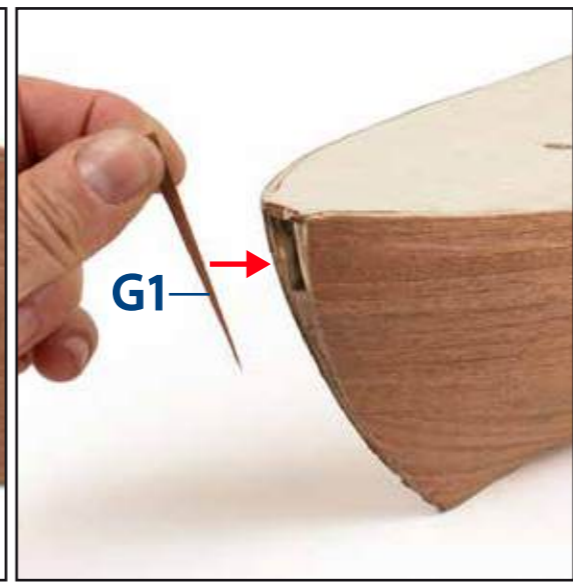
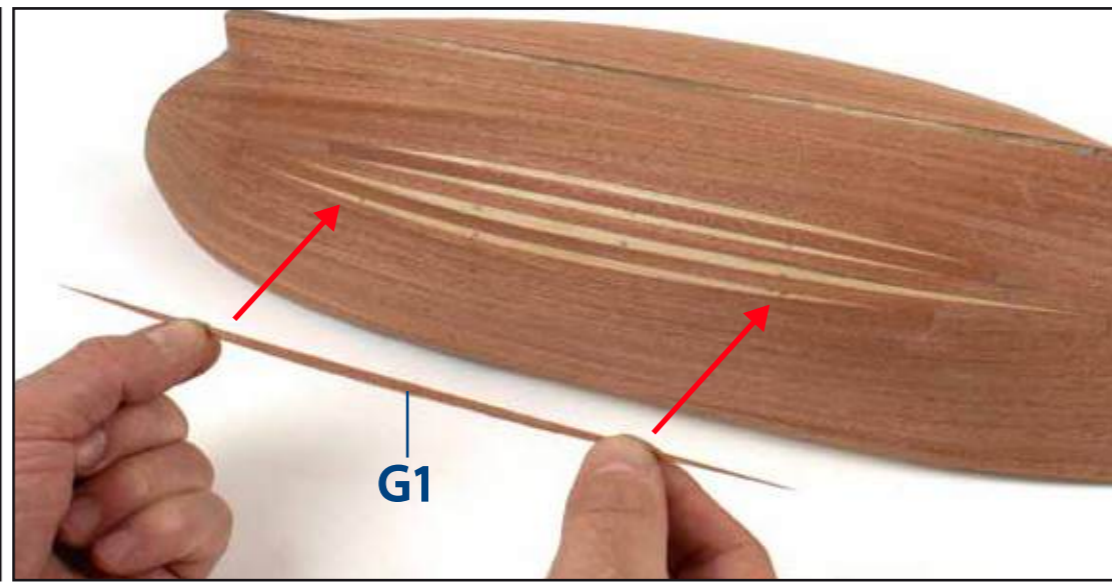
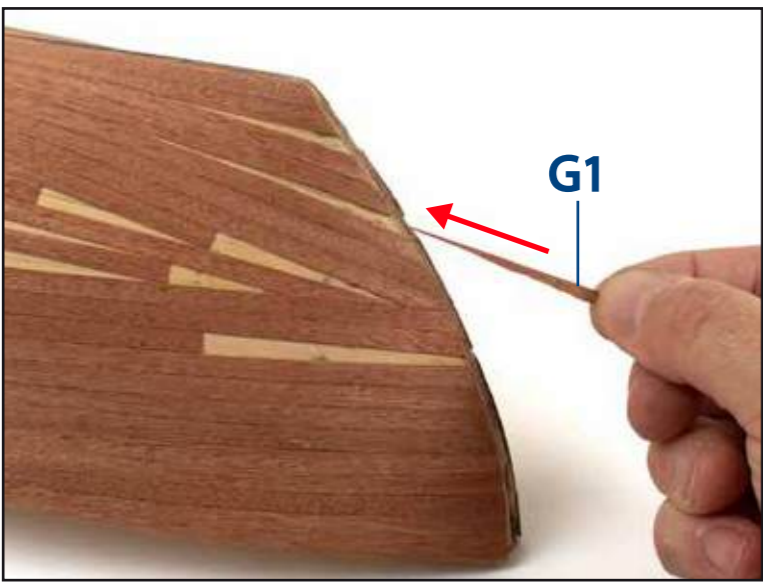

H

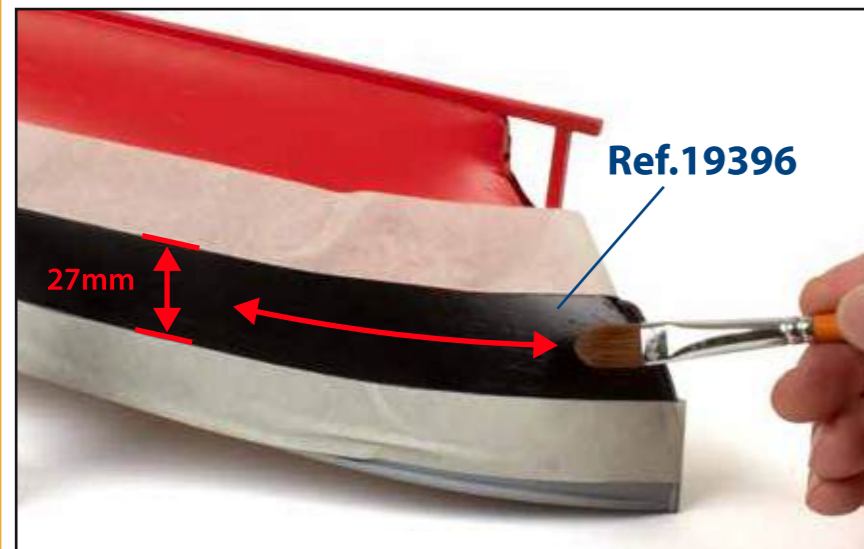
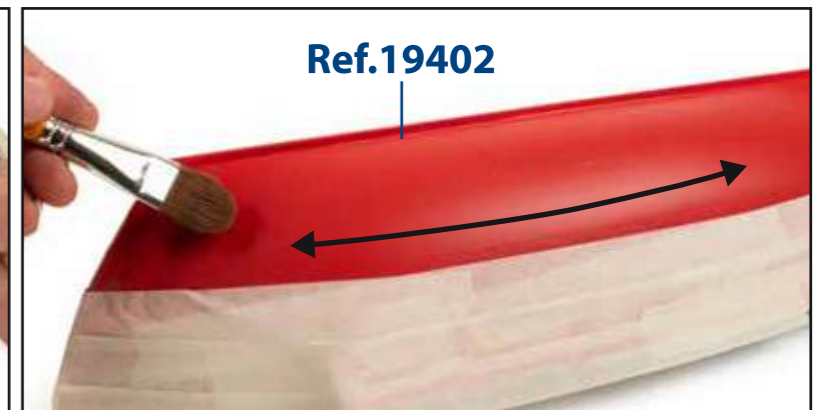
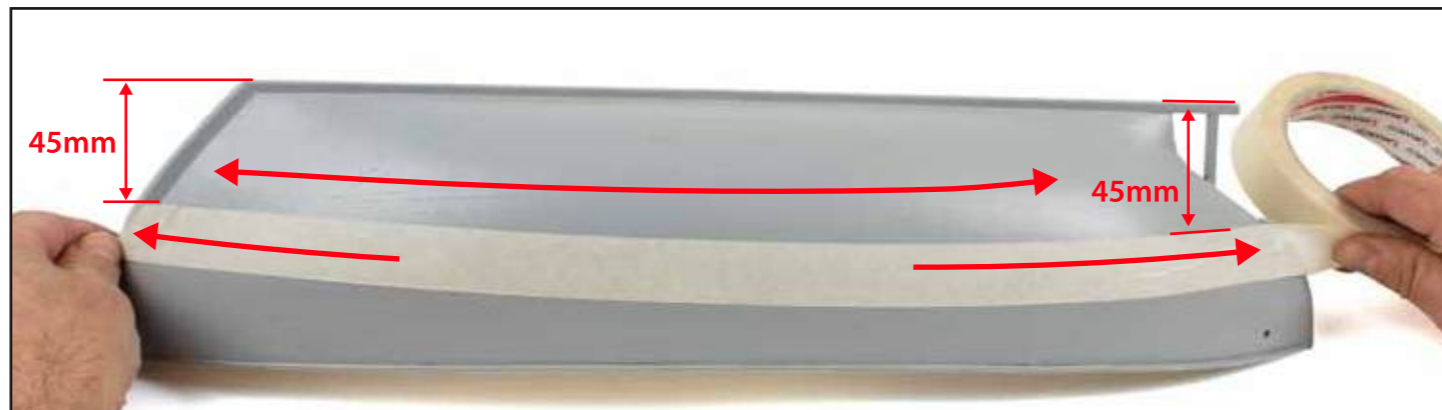
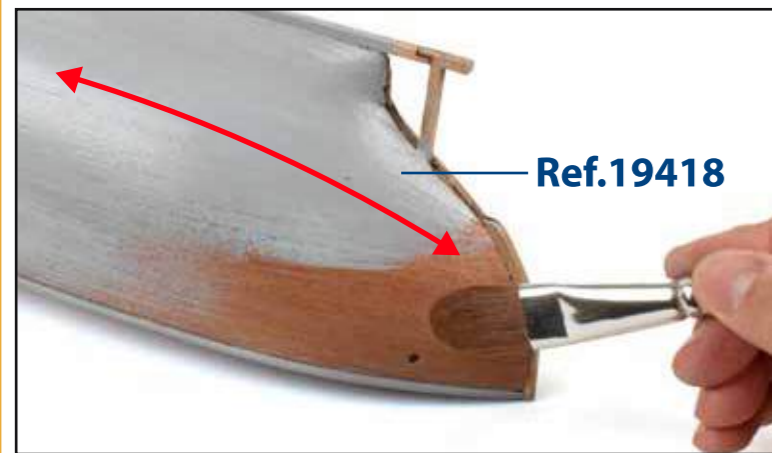
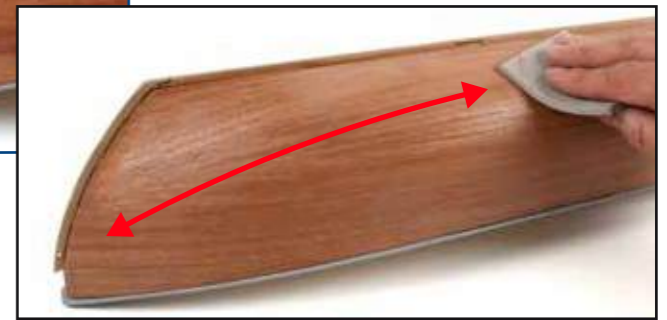
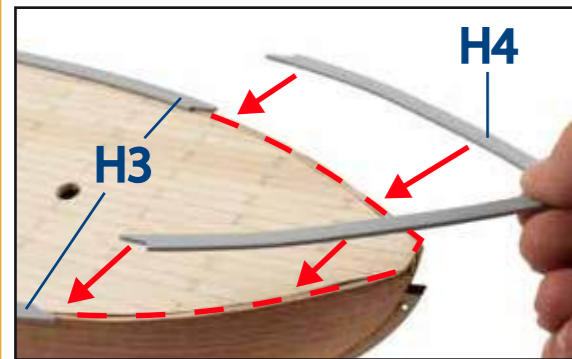
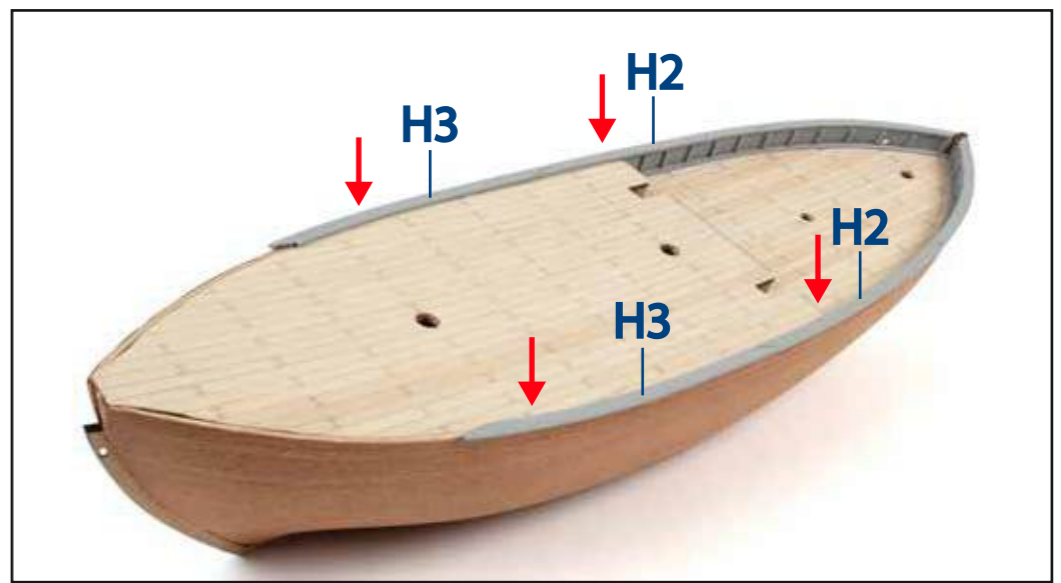
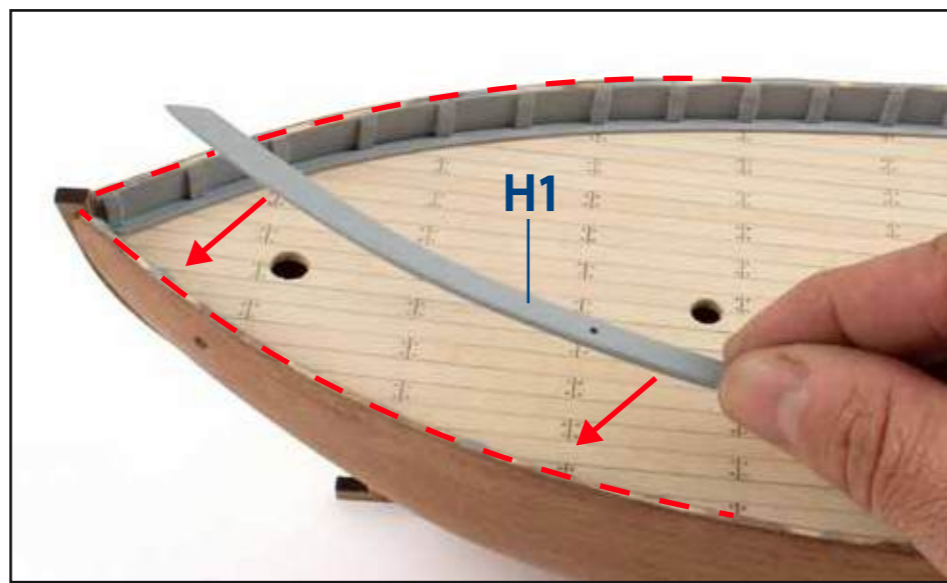
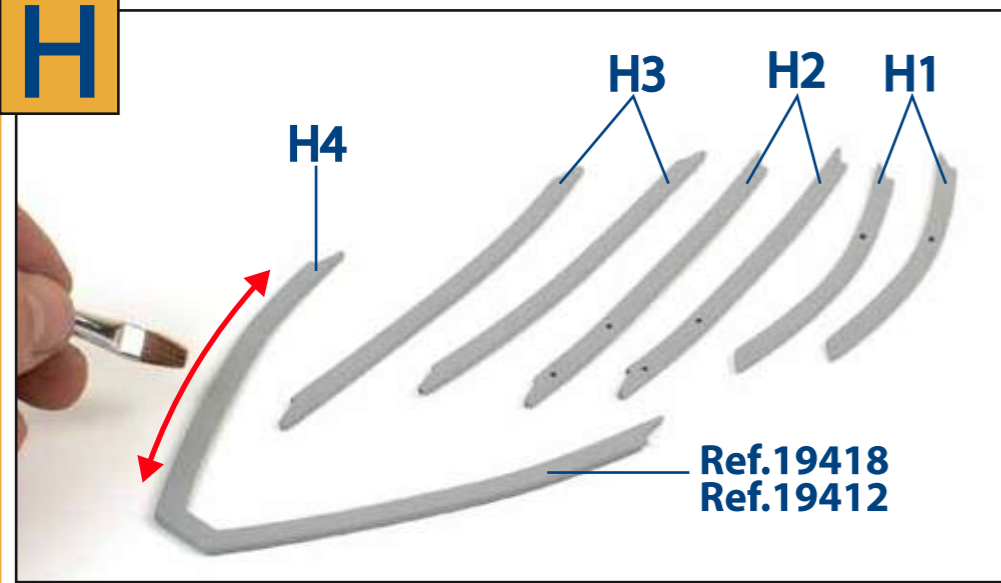

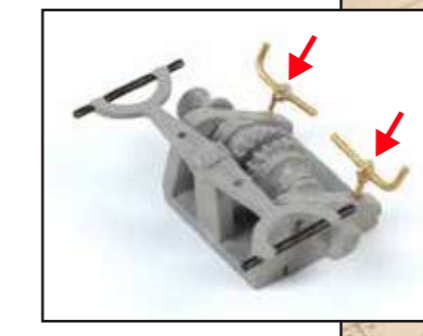
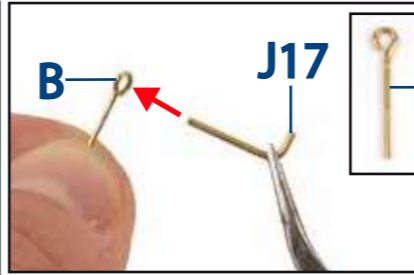
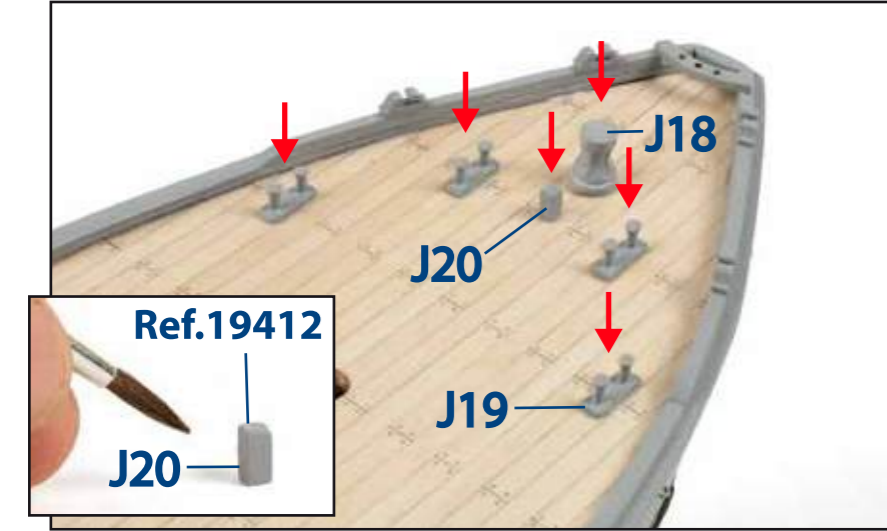
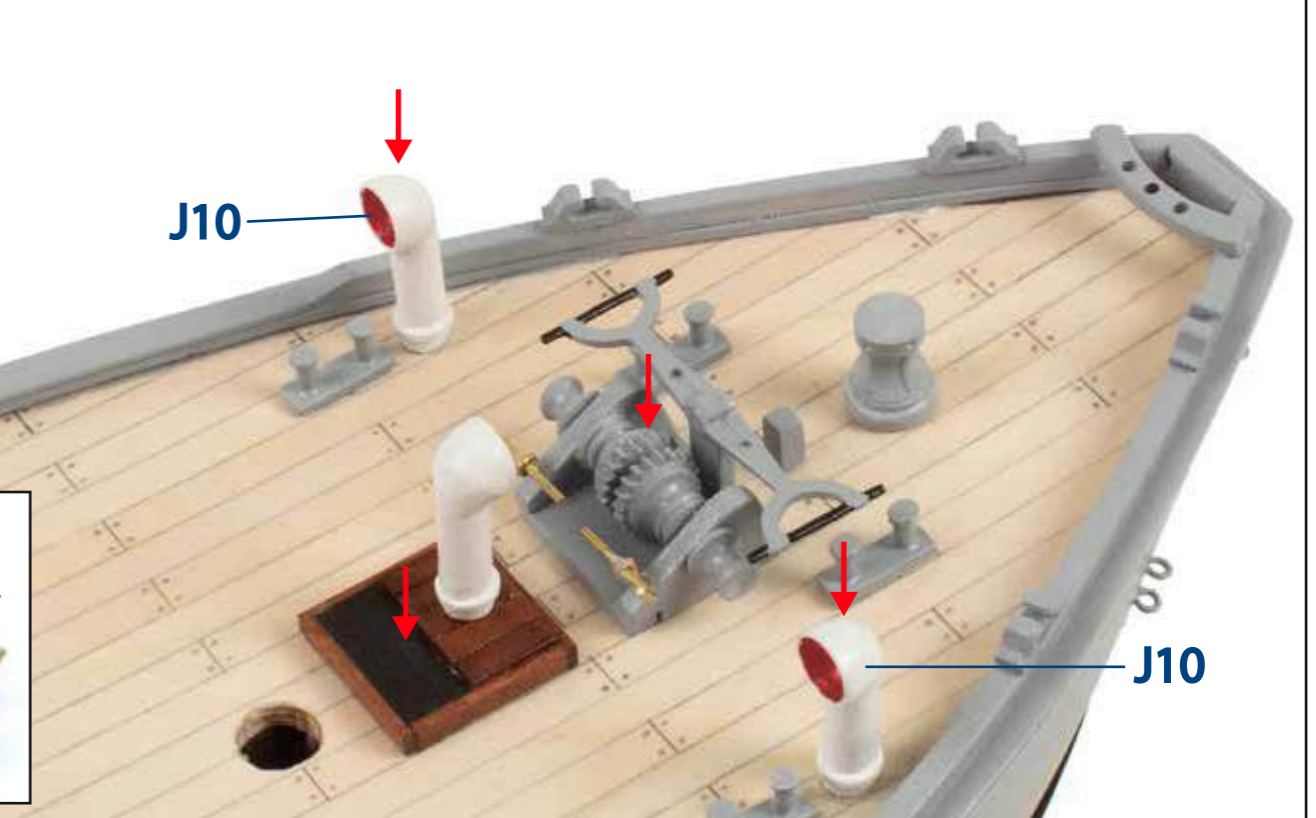
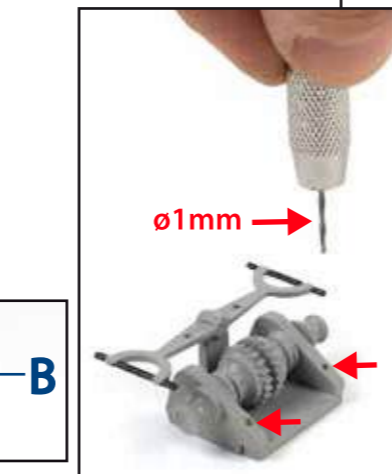
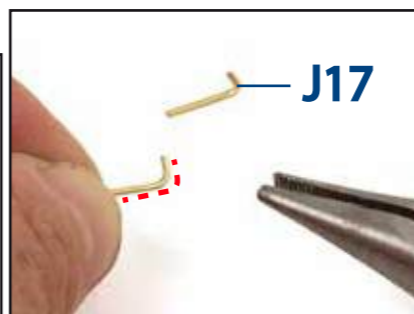
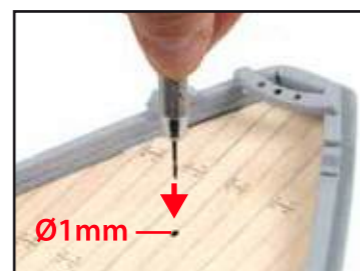
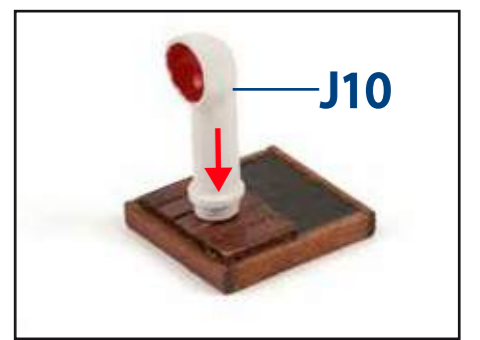
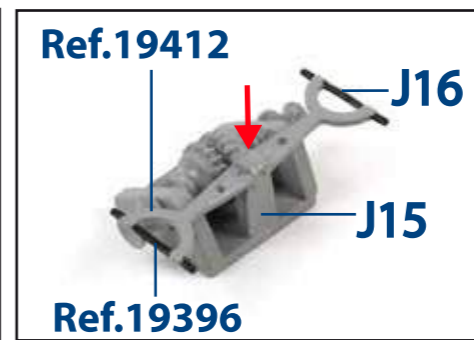
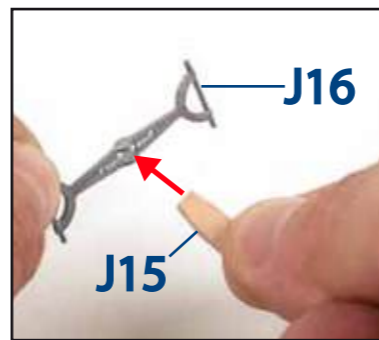
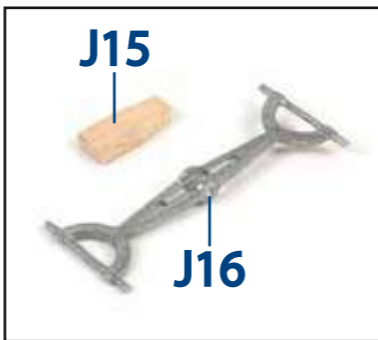
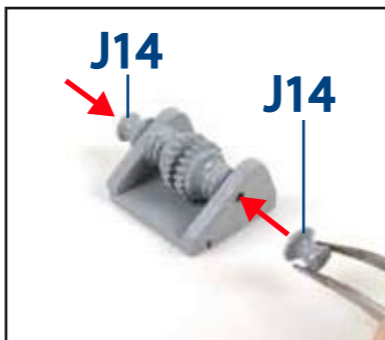
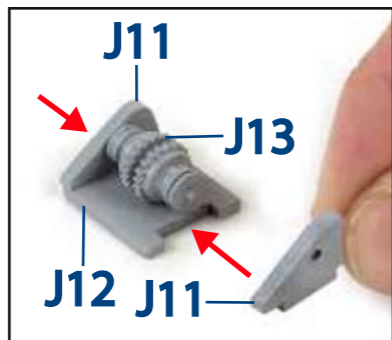
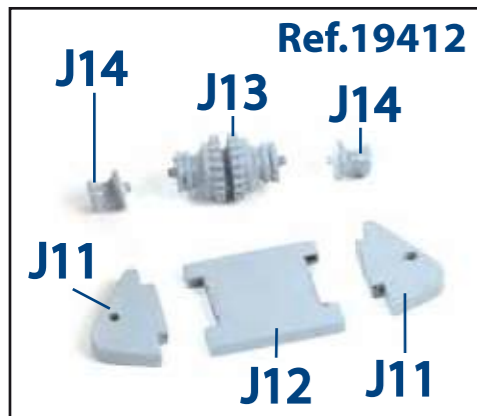
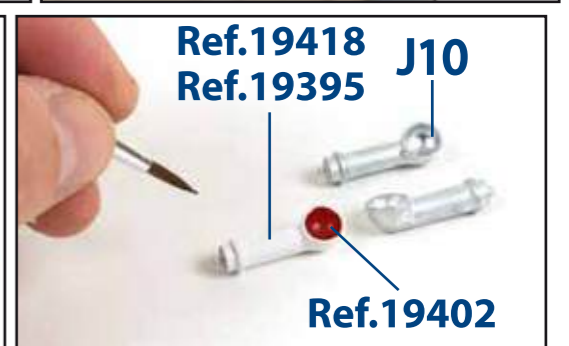
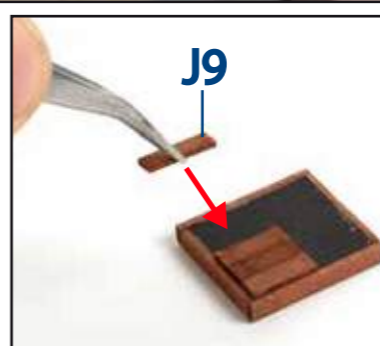
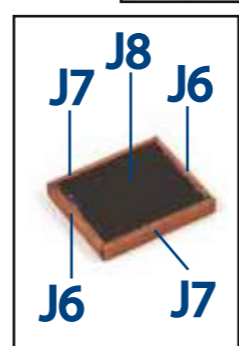
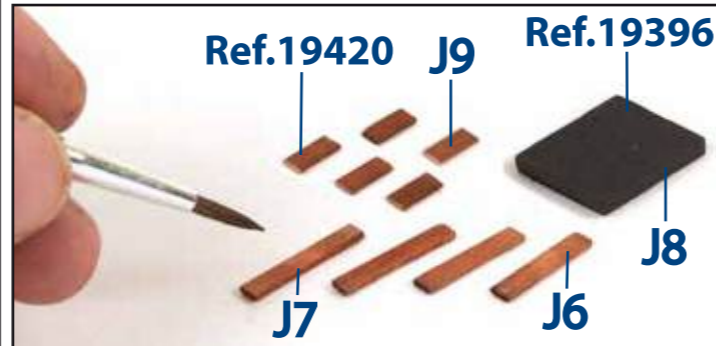
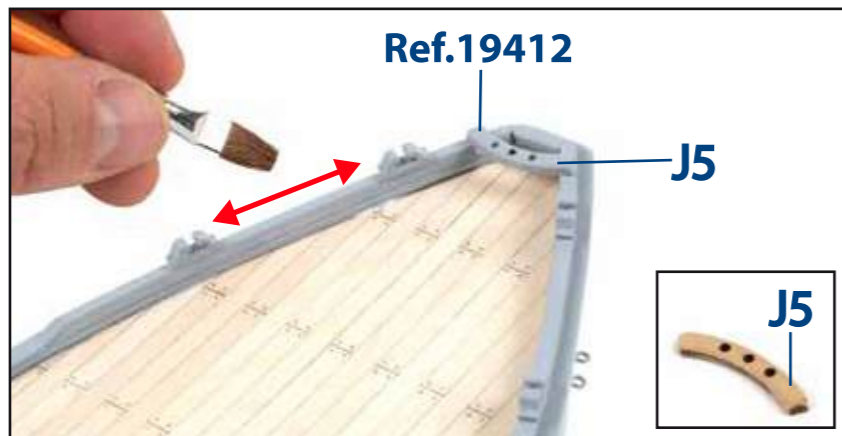
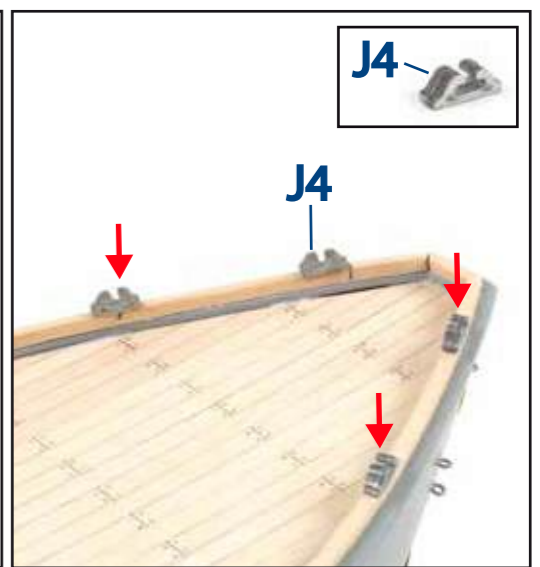
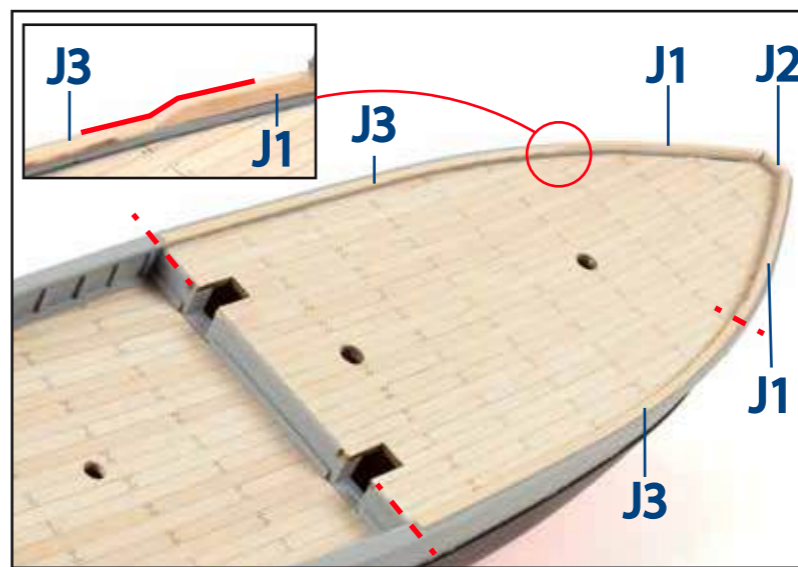
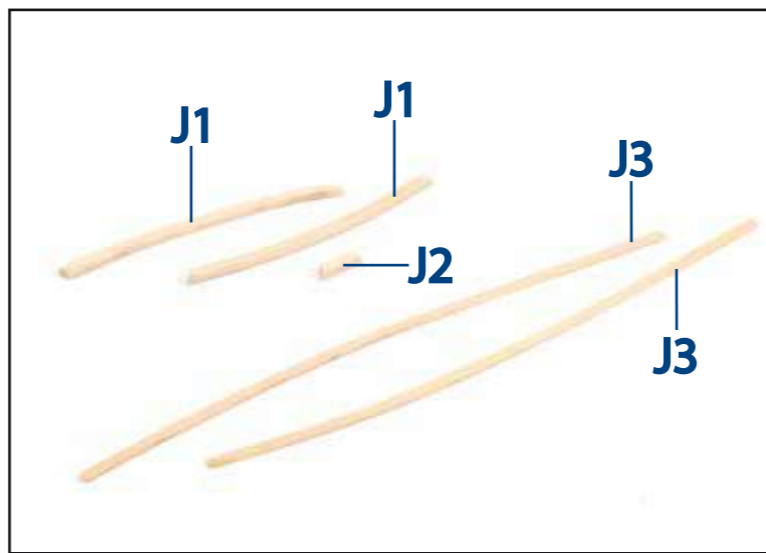

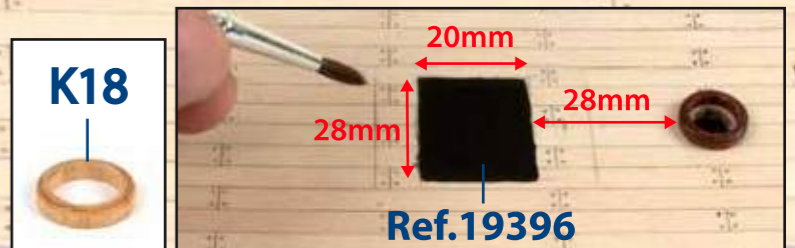
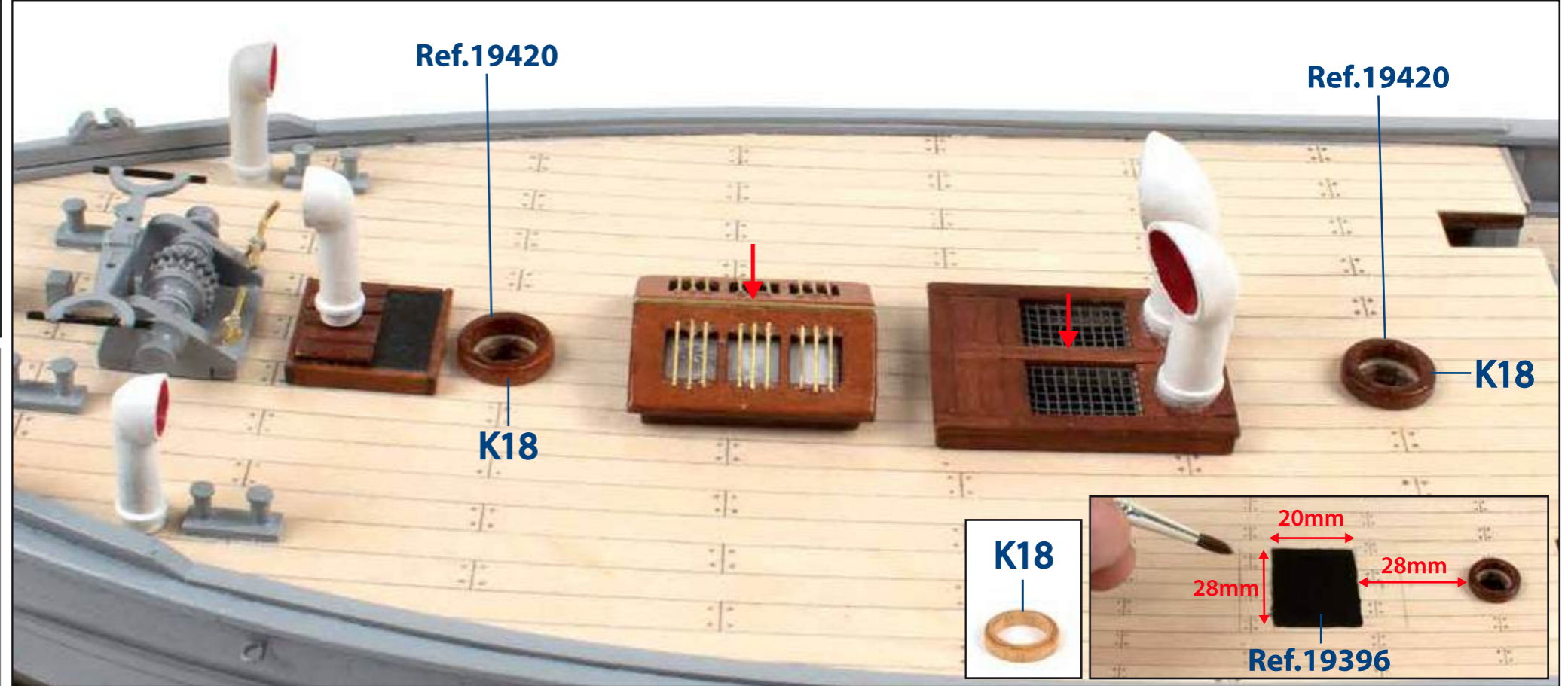
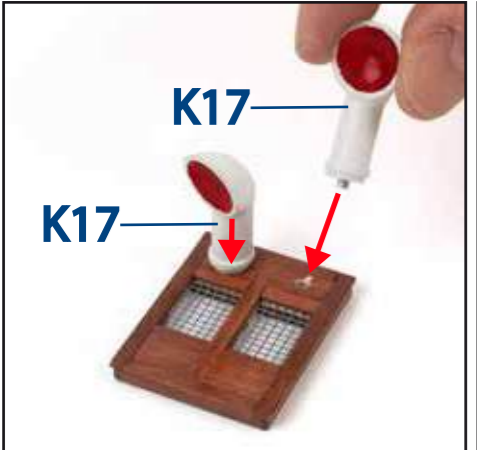
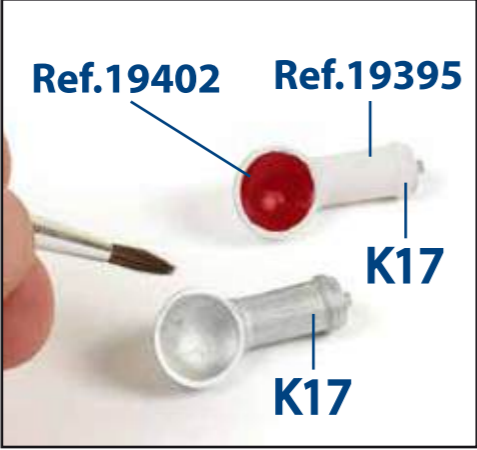
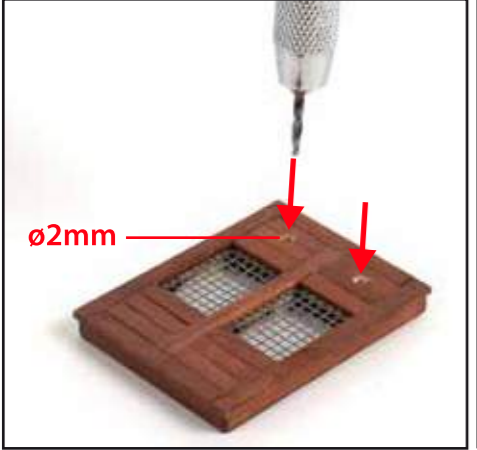
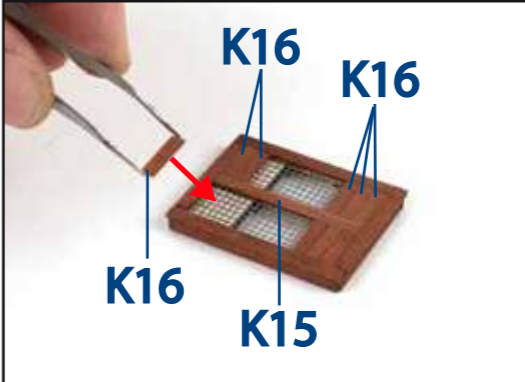
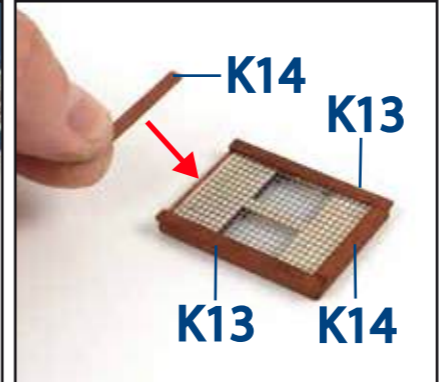
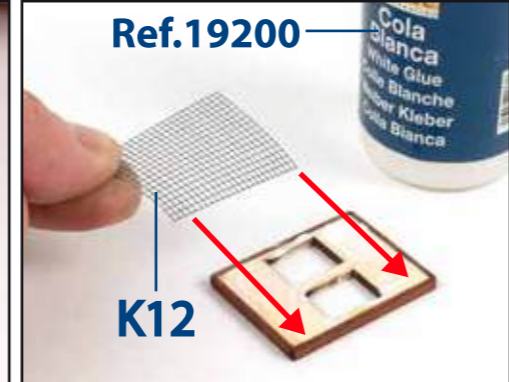
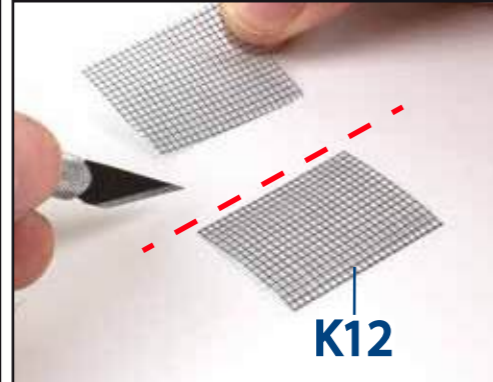
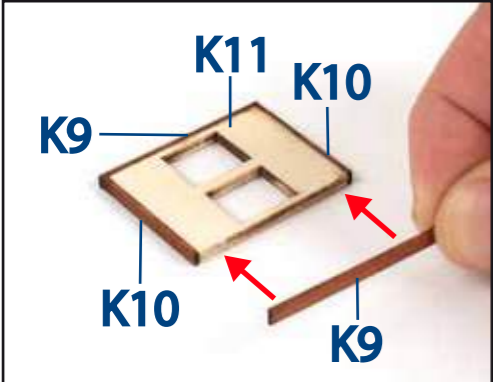
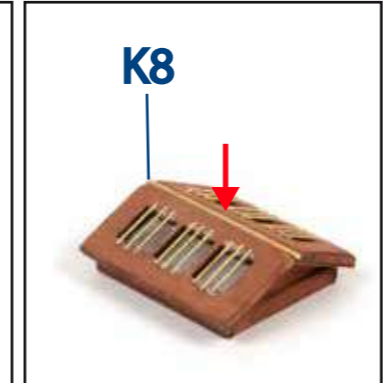
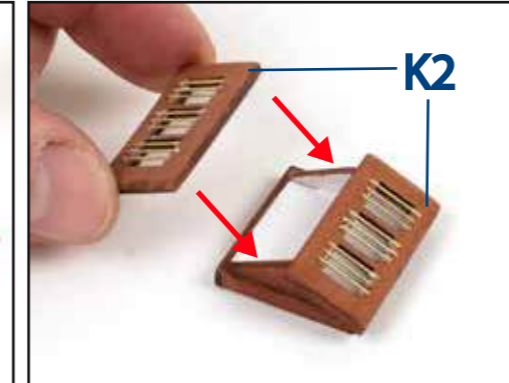
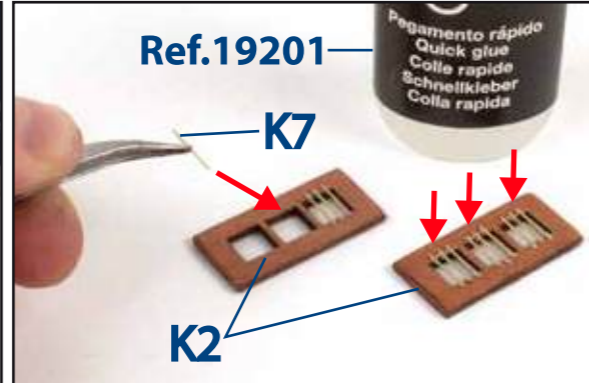
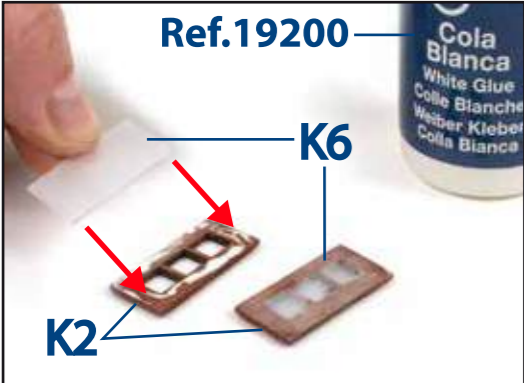
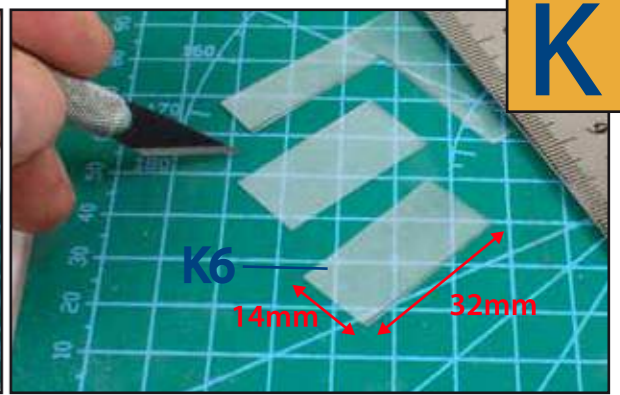
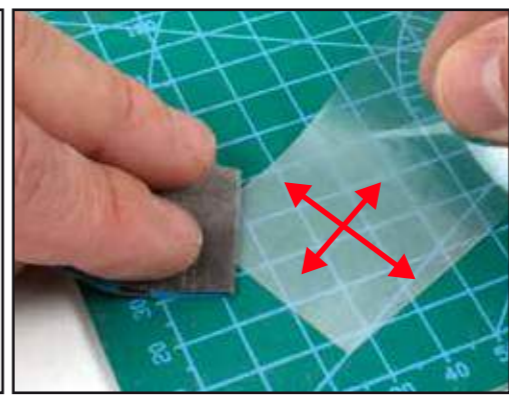
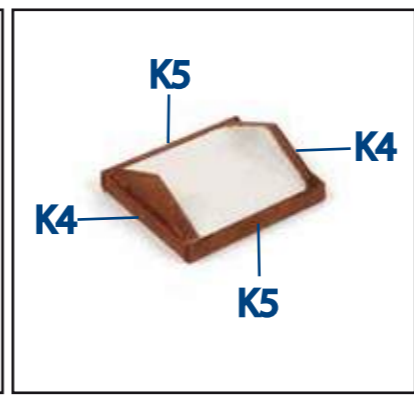
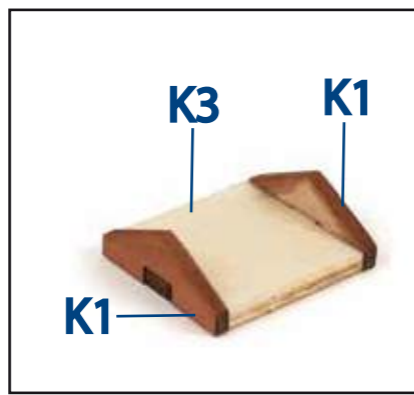

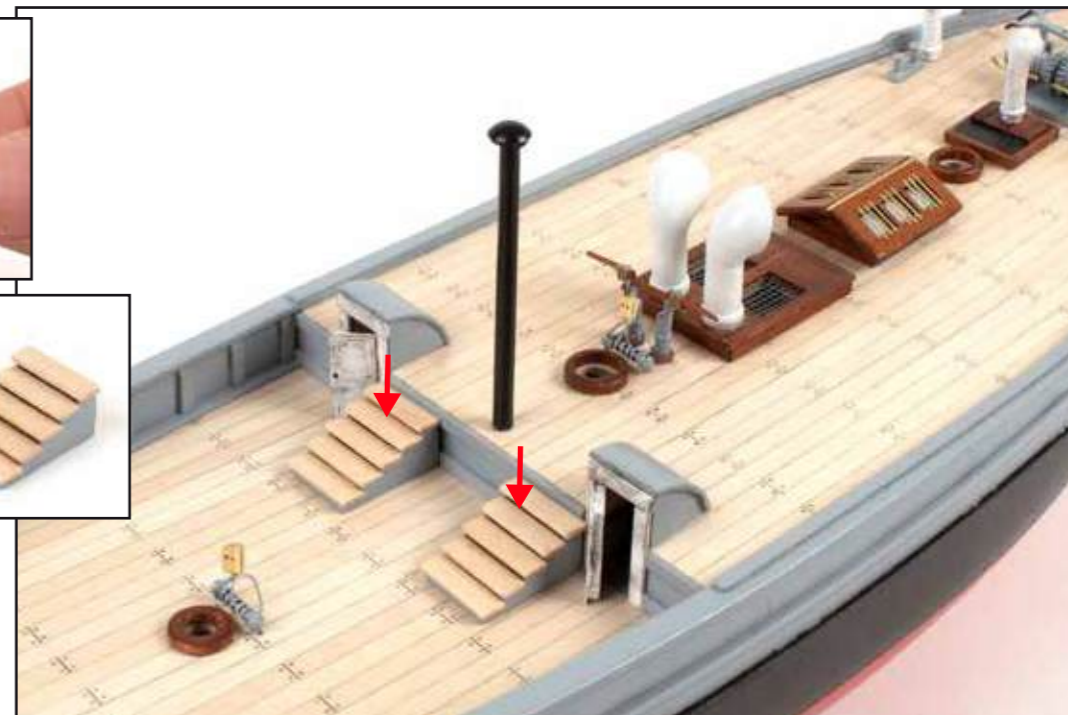
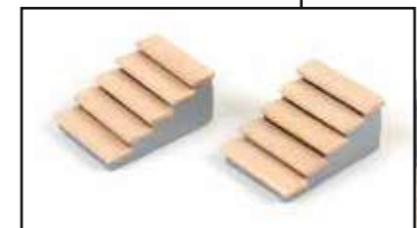
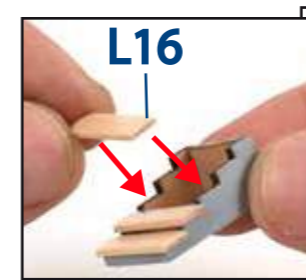
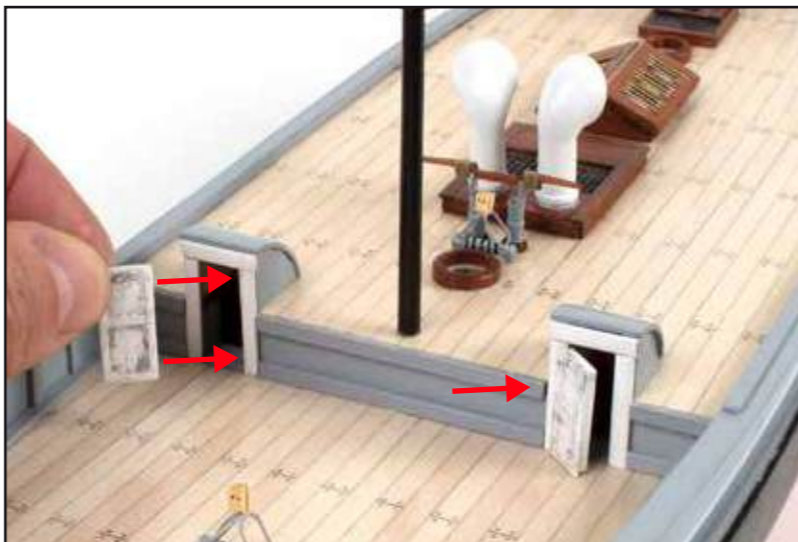
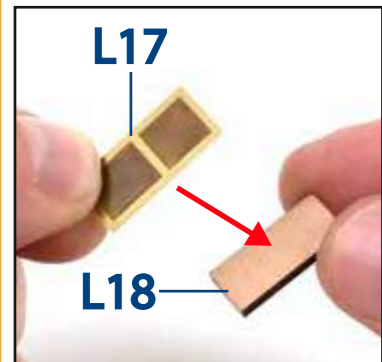
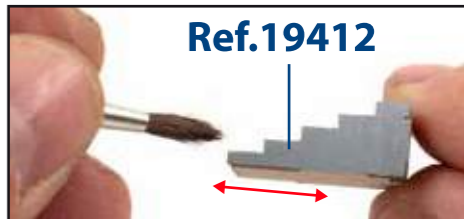
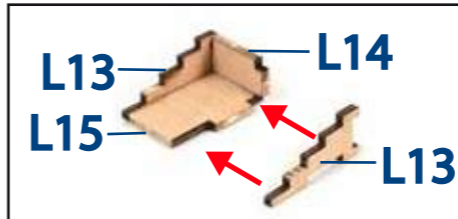
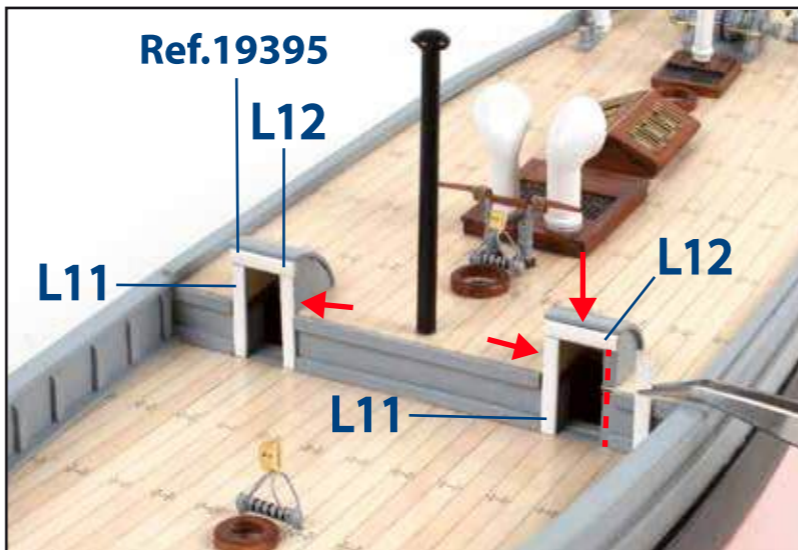
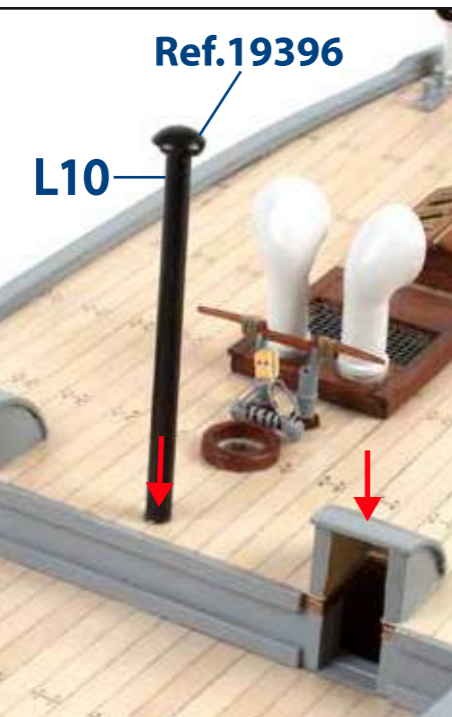
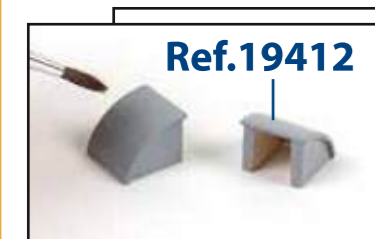
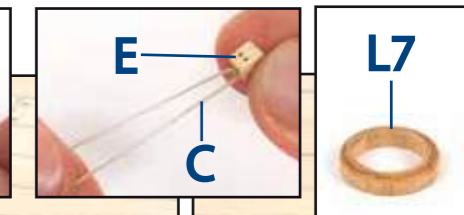
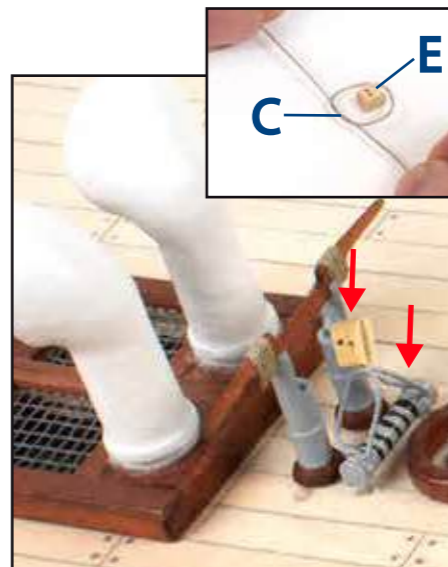
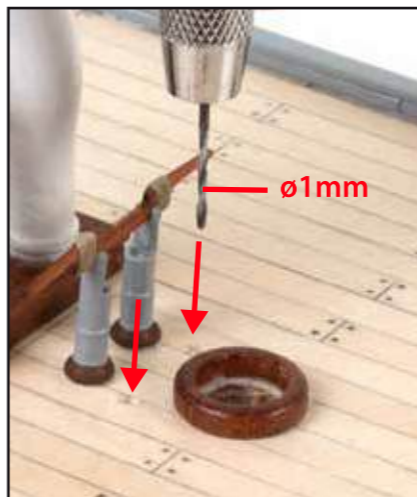
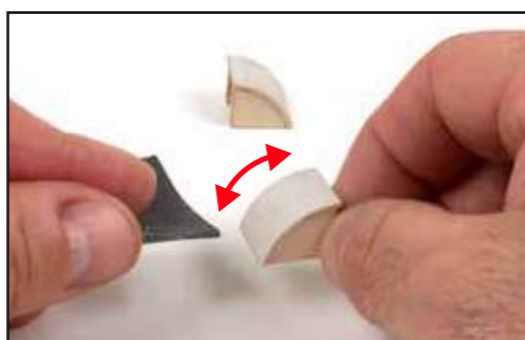
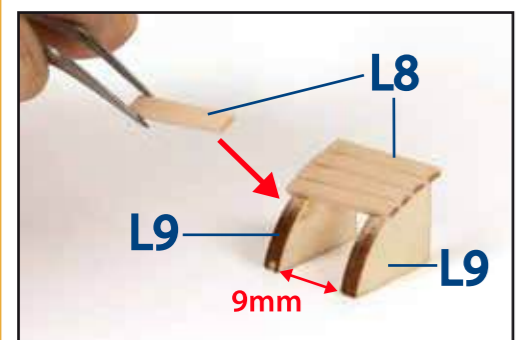
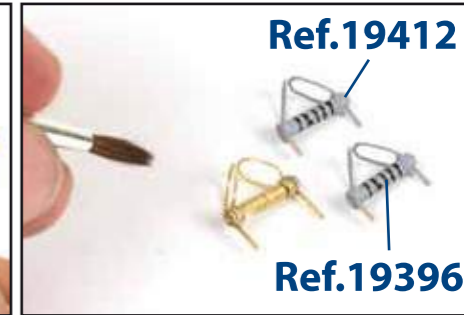
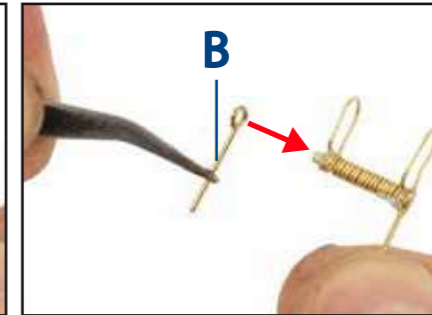
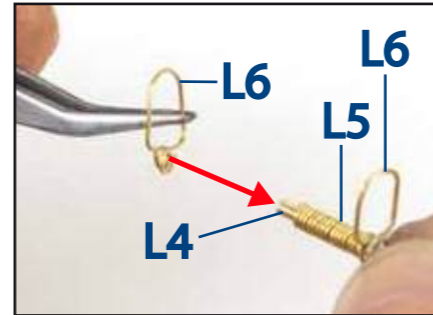
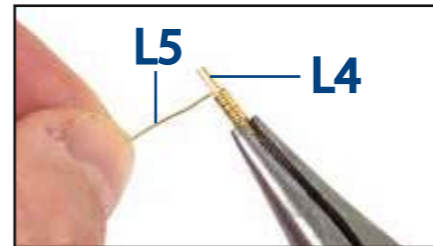
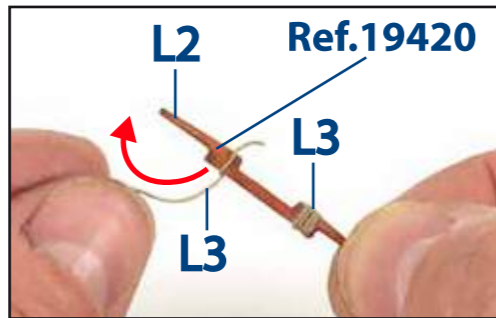
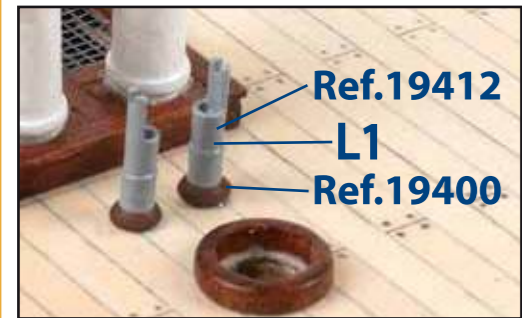
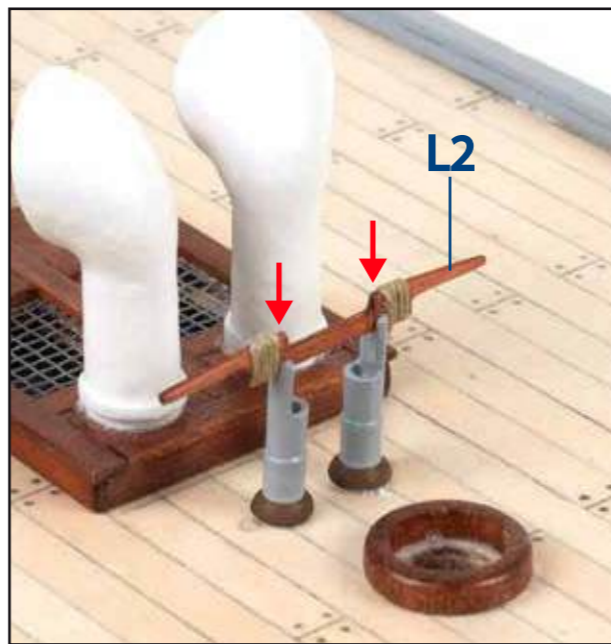
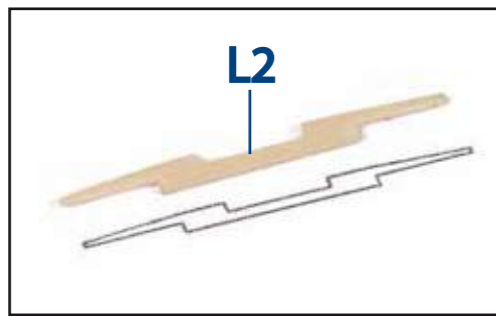
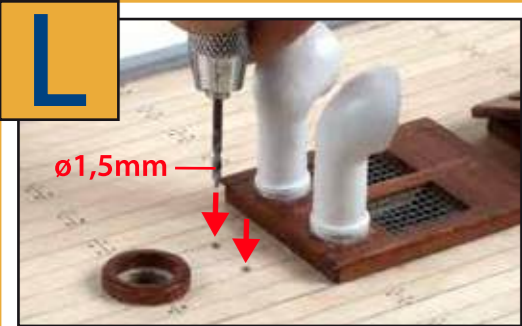

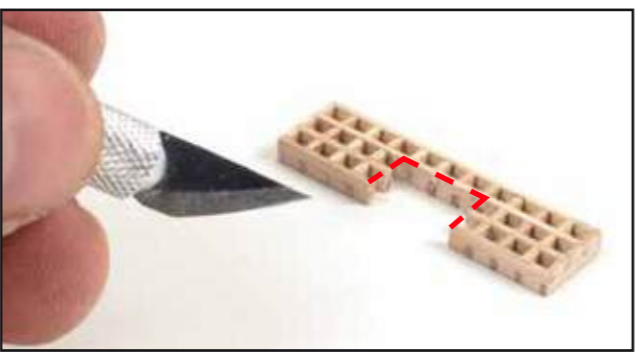
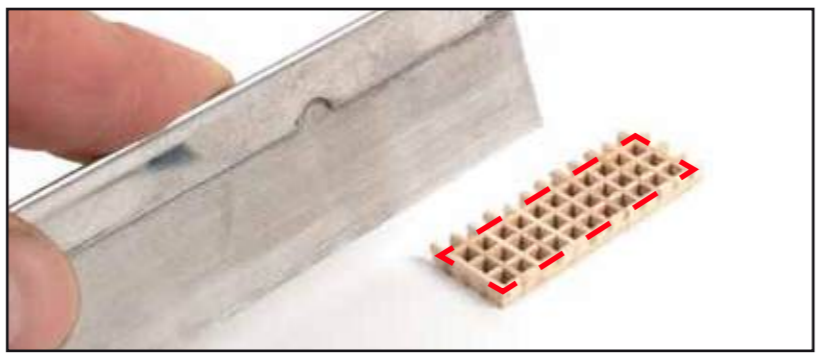
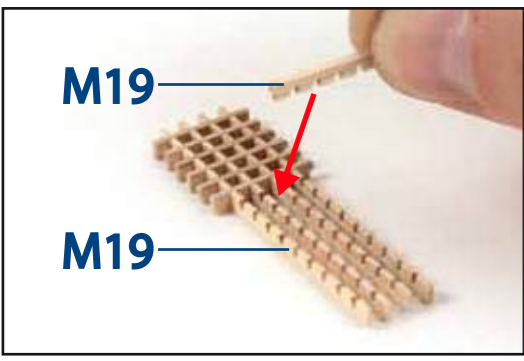
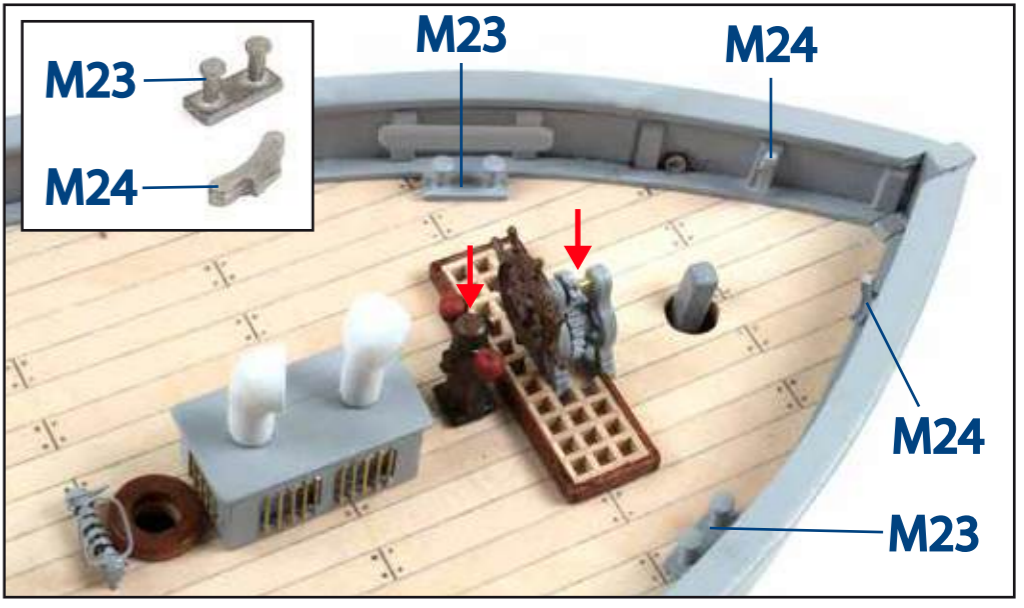
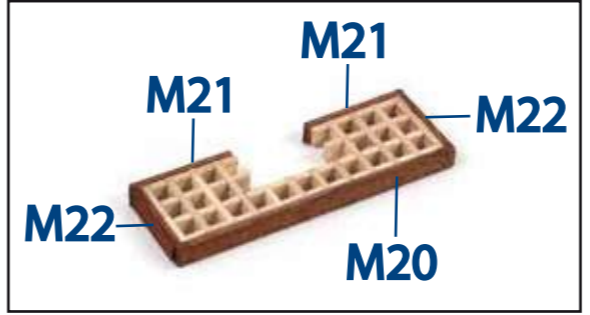
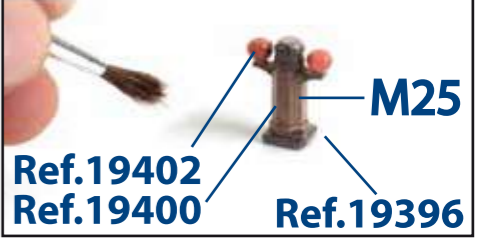
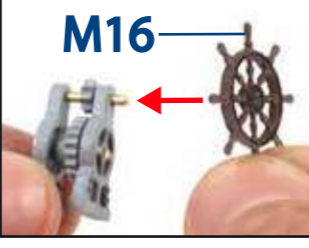
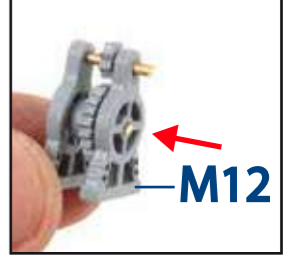
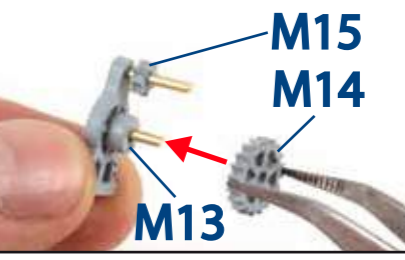
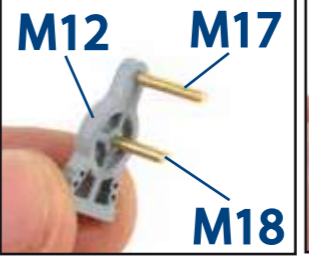
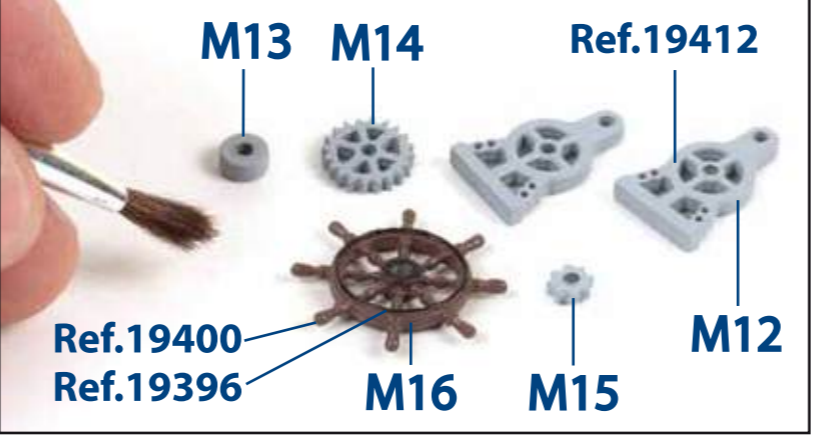
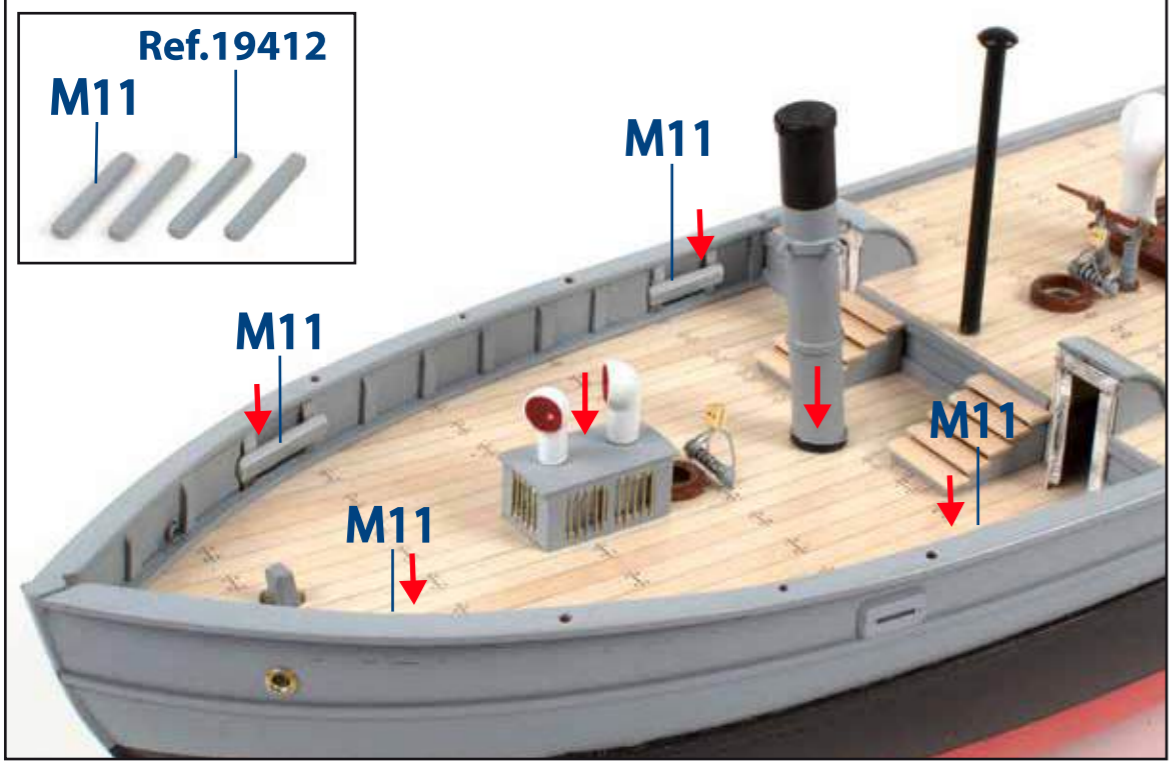
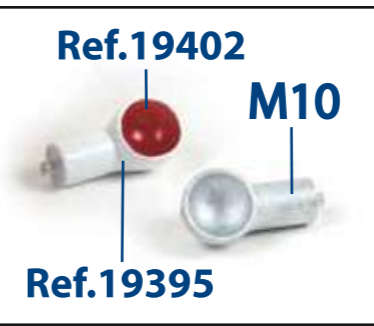
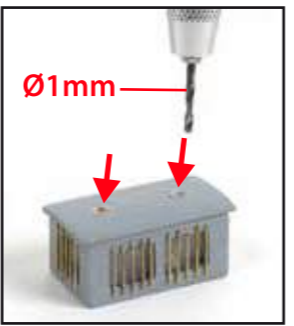
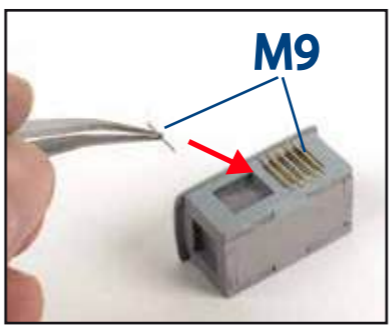
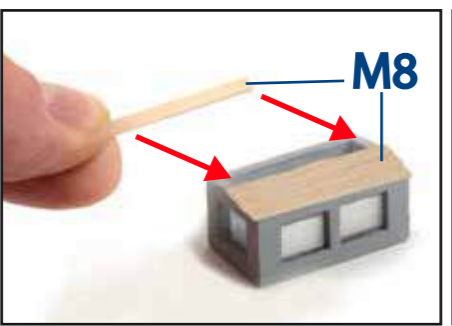
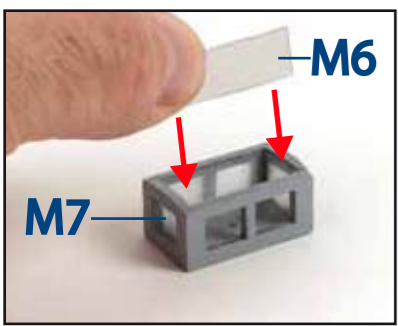
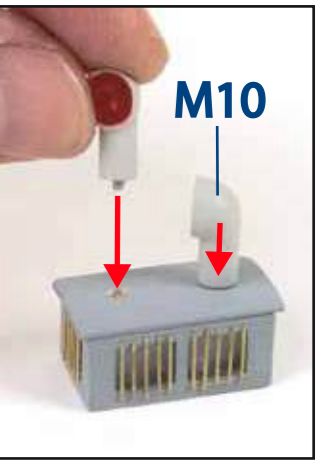
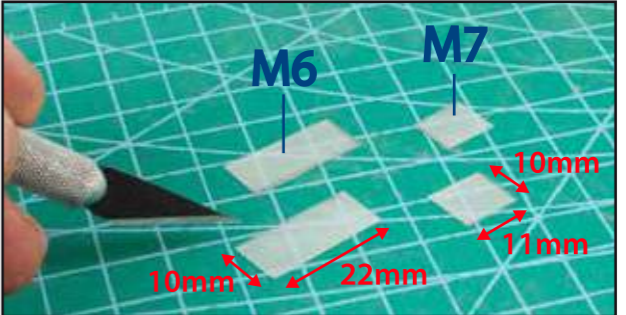
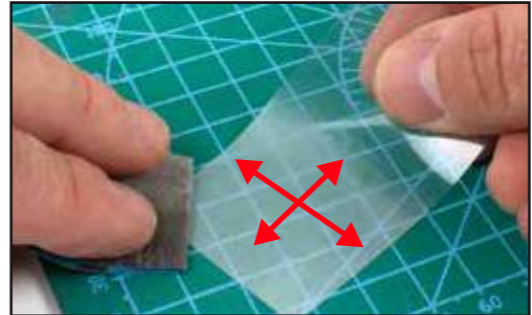
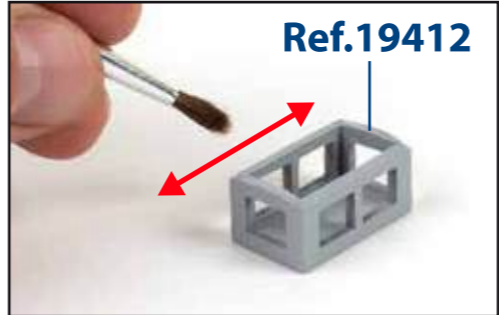
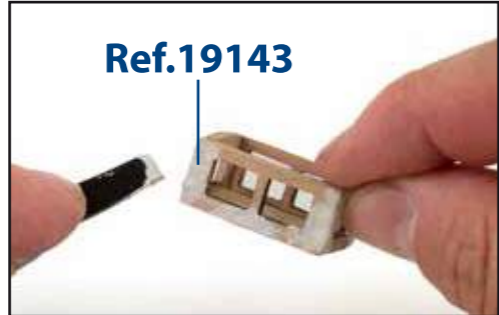
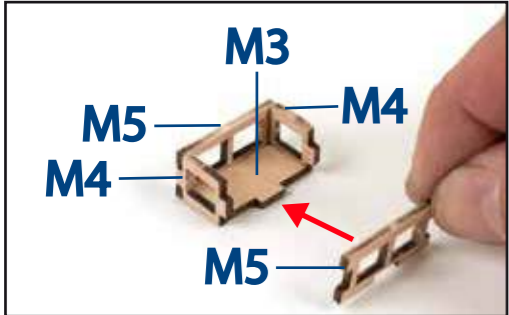
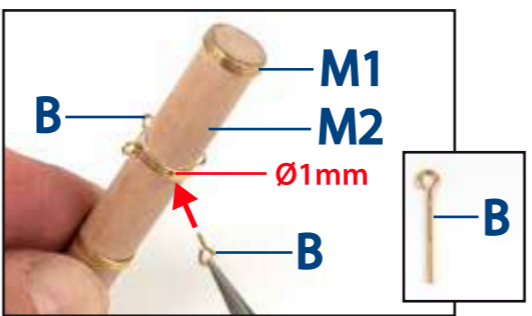
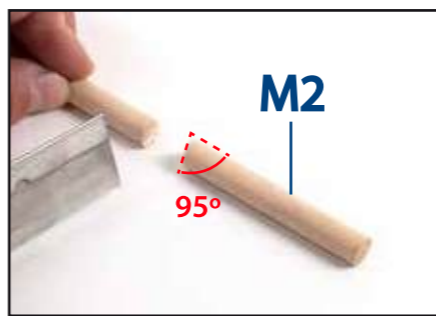
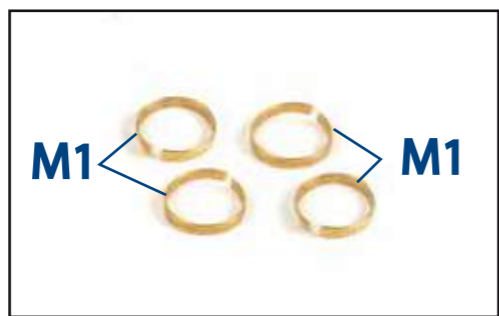
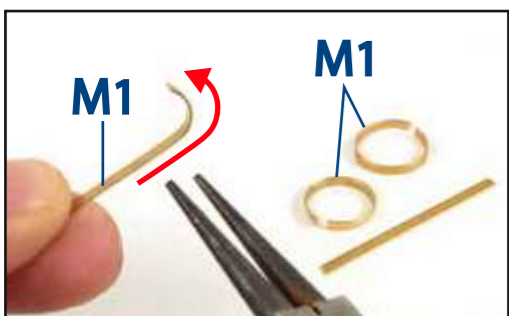

N

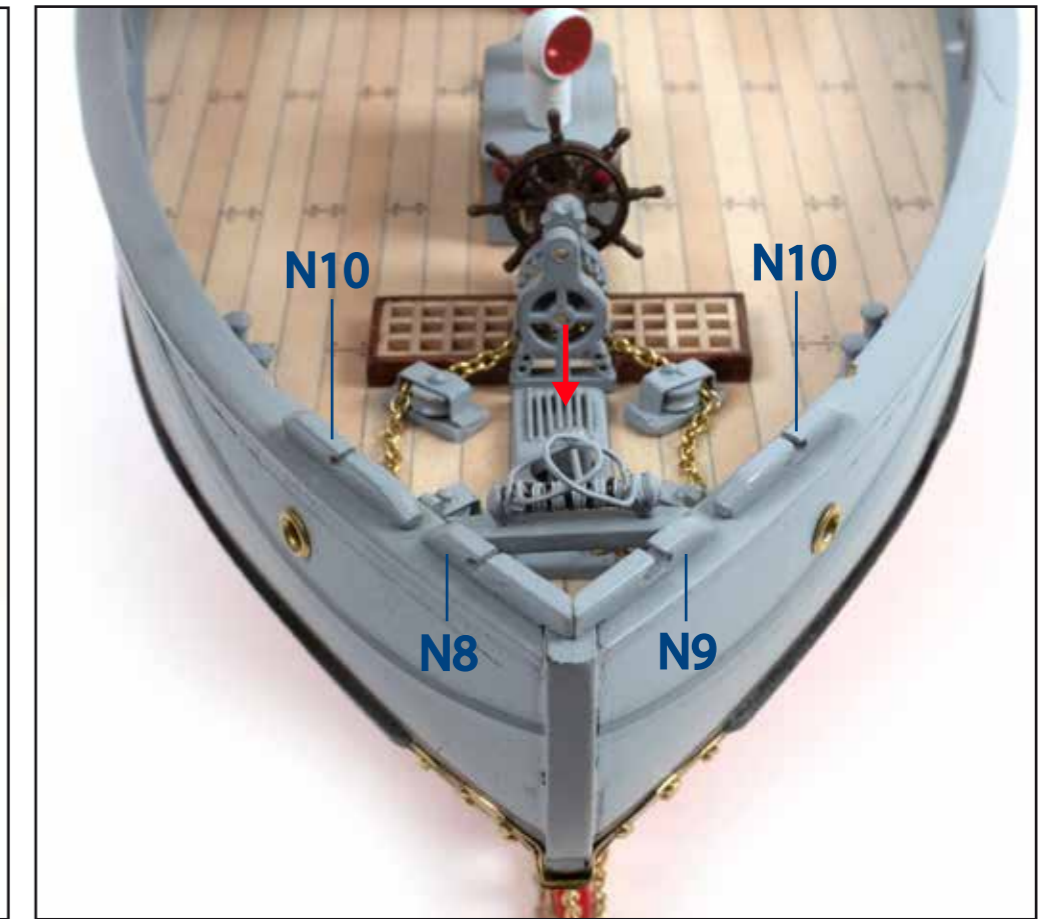
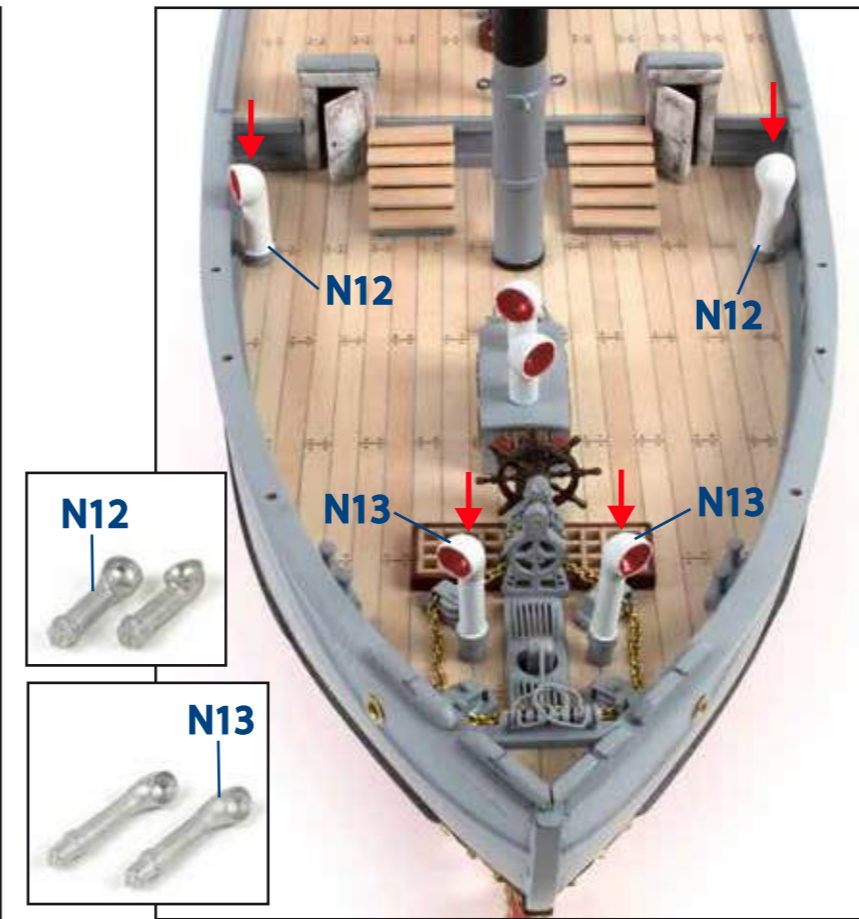
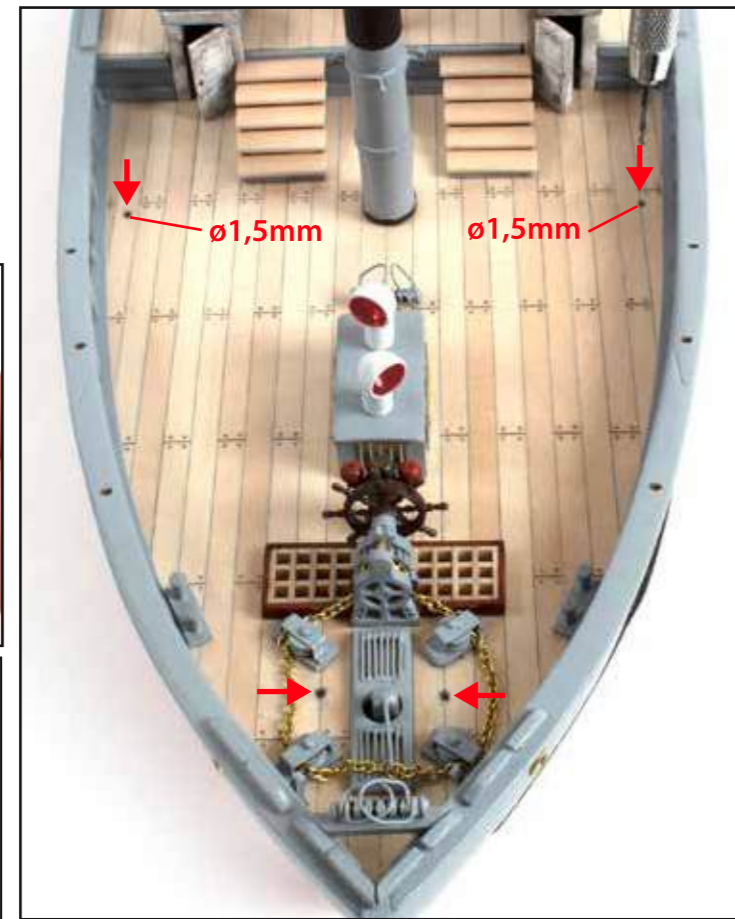
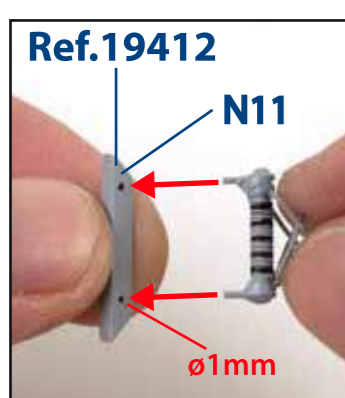
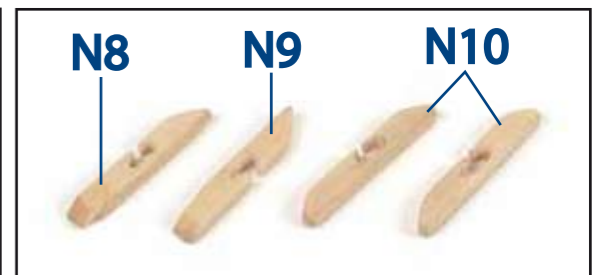
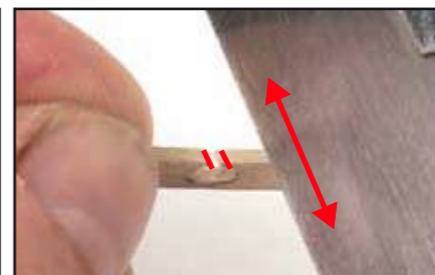
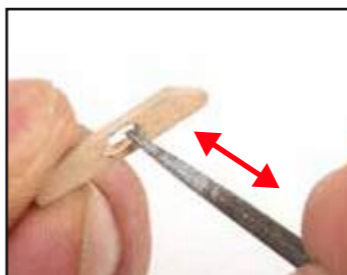
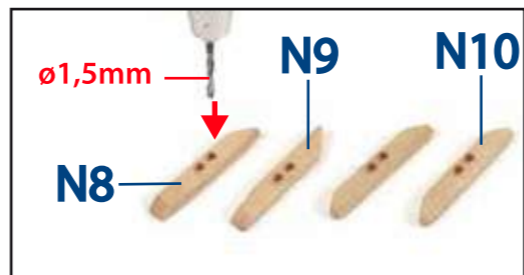
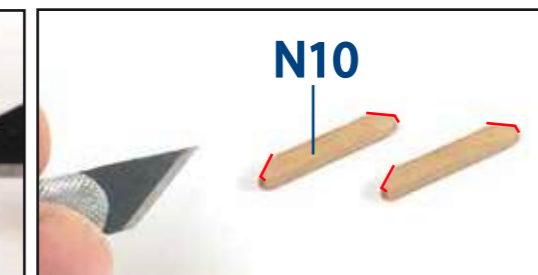
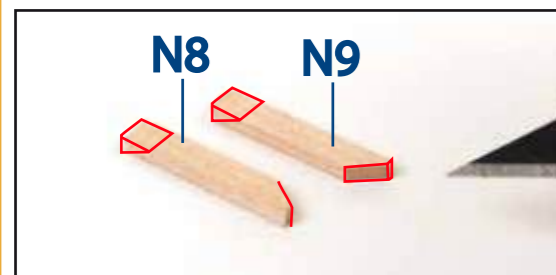
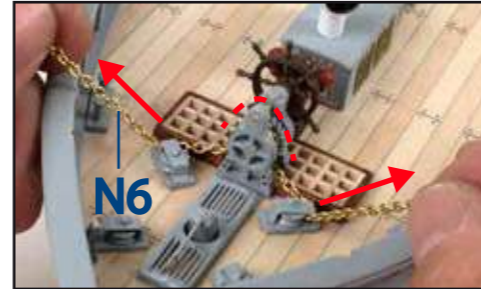
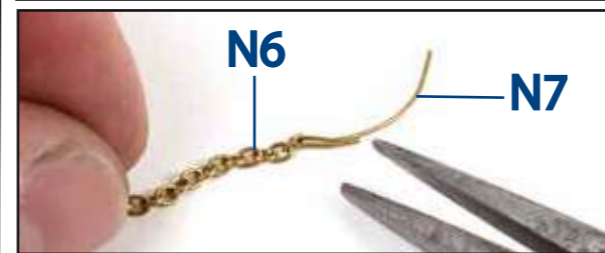
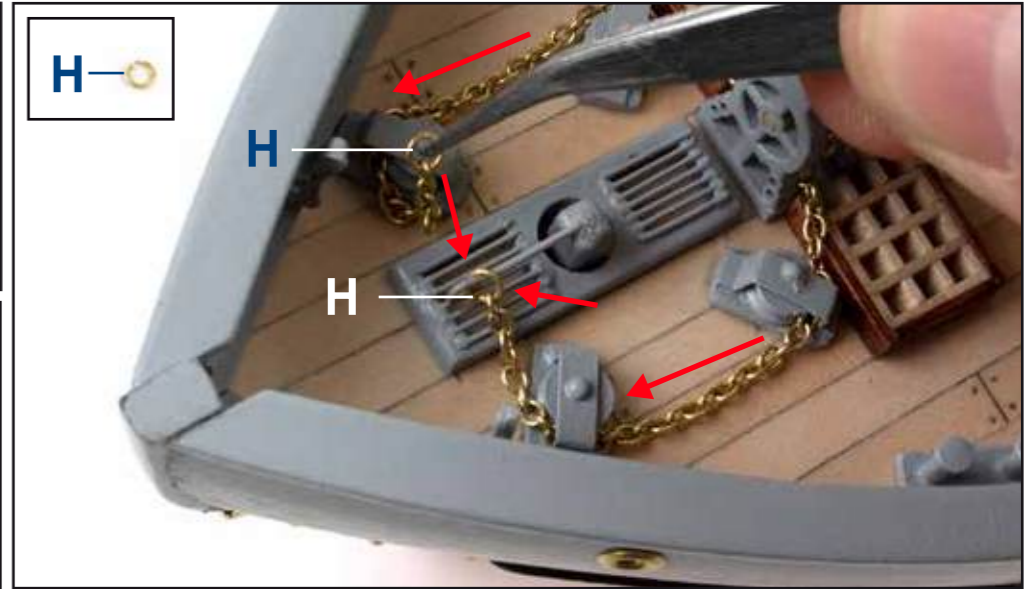
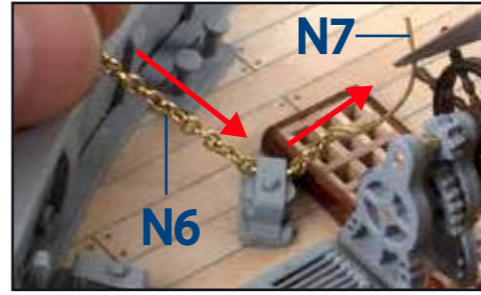
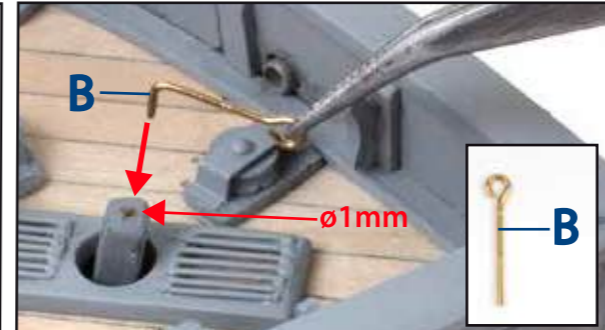
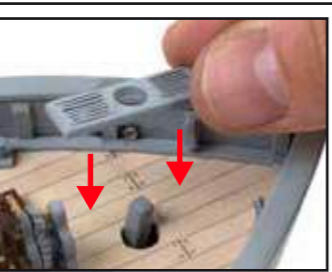
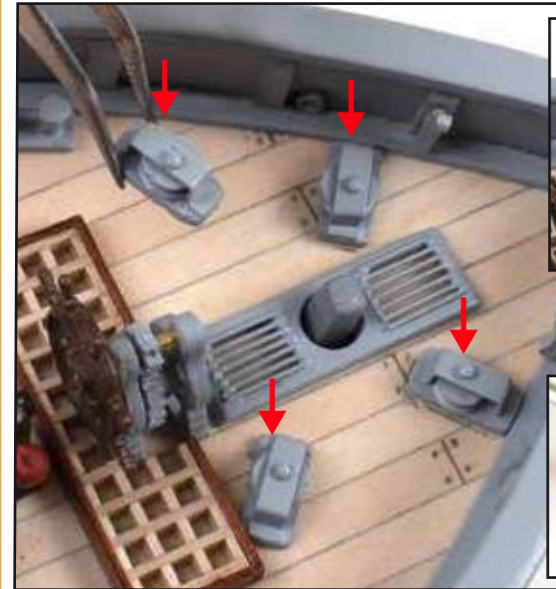
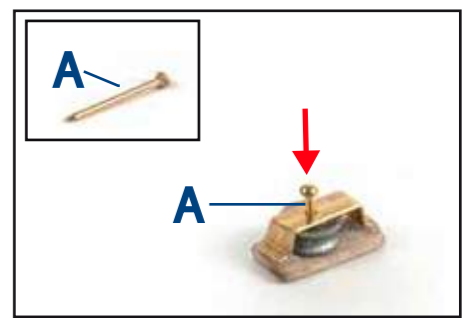
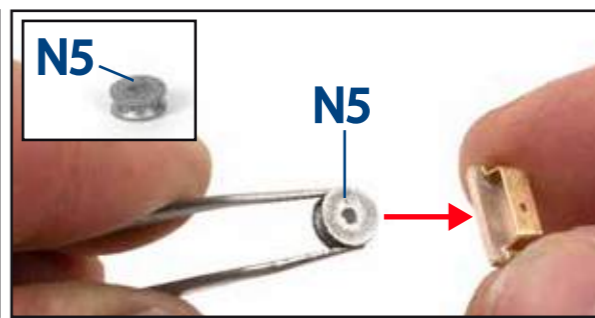
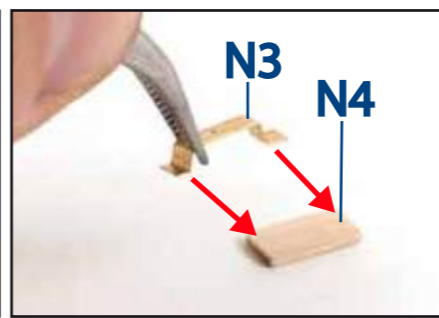
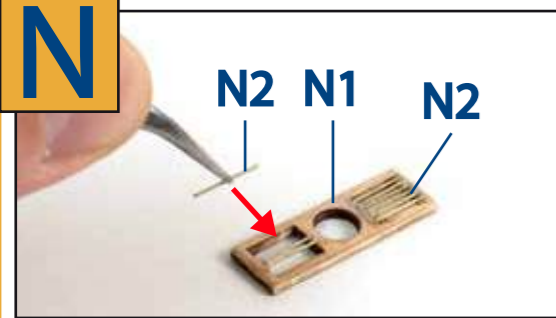

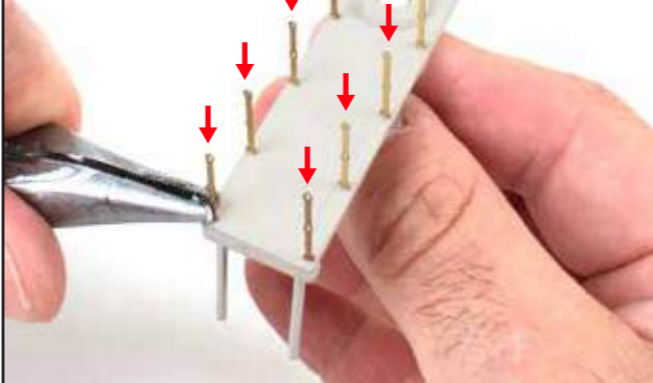
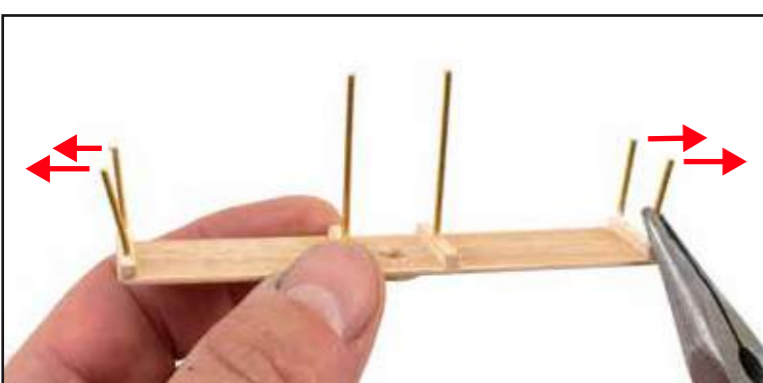
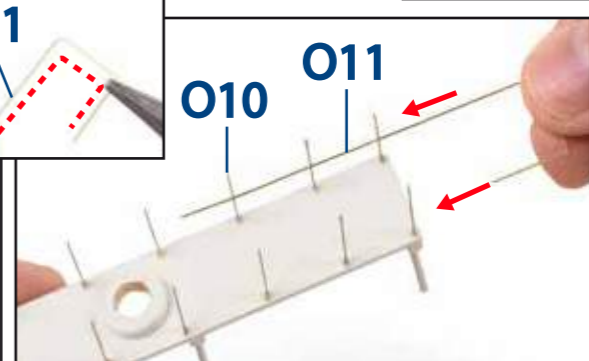
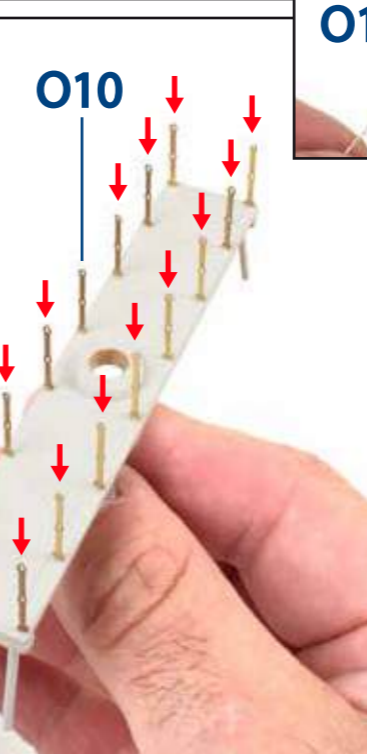
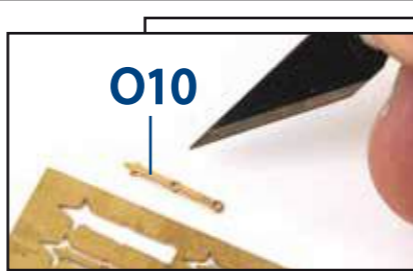
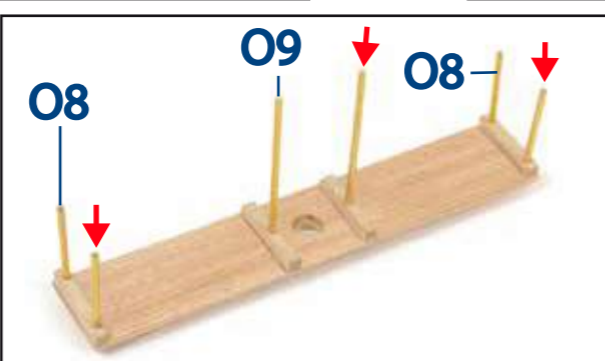
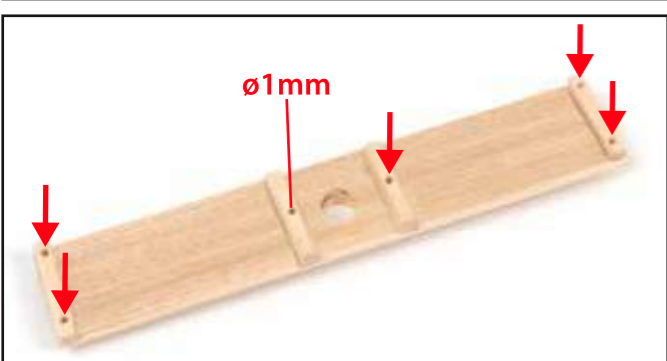
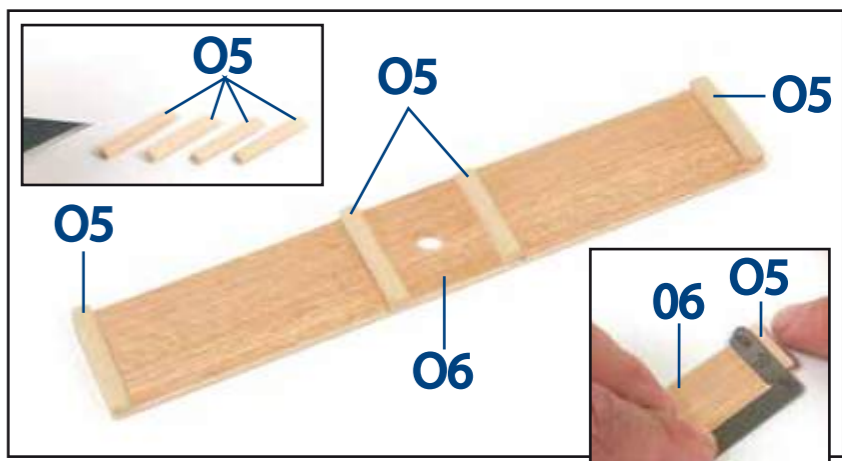
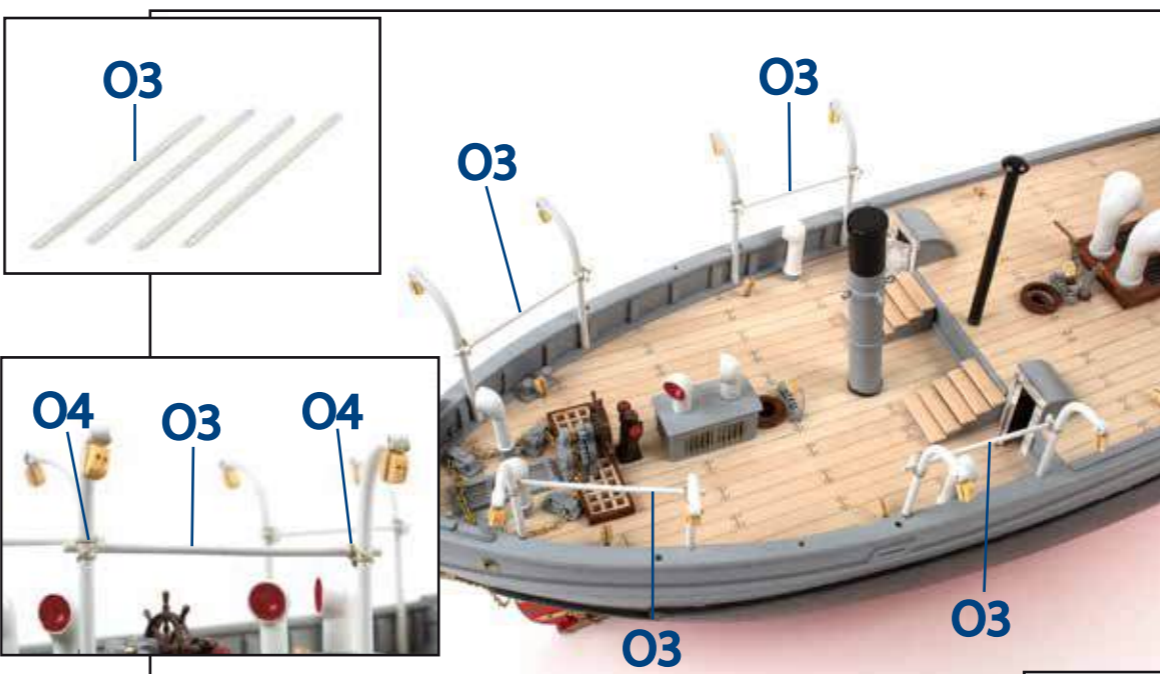
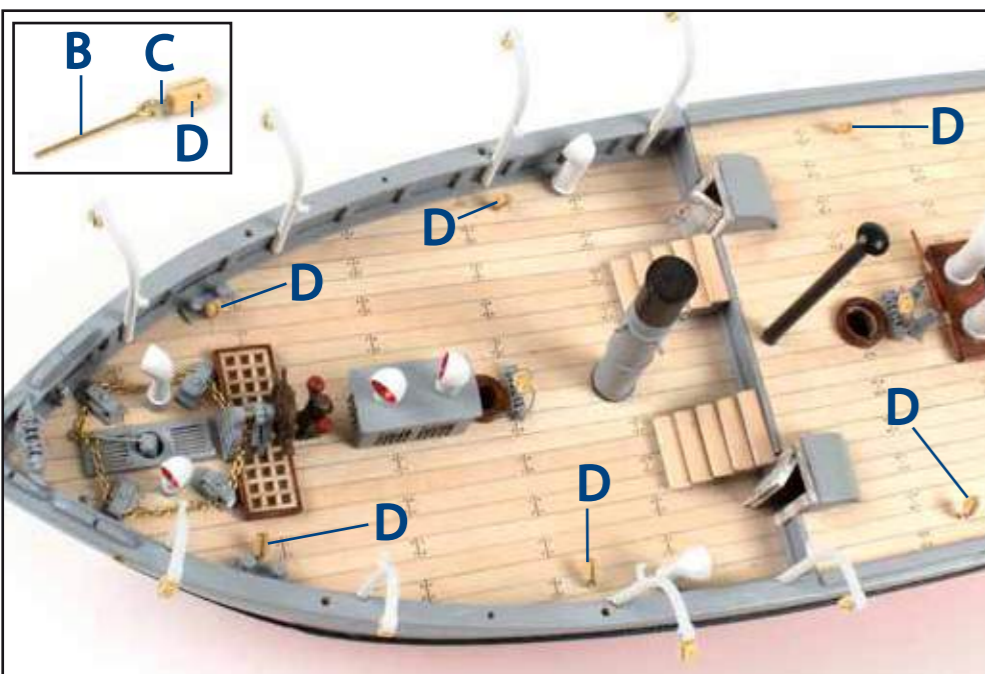
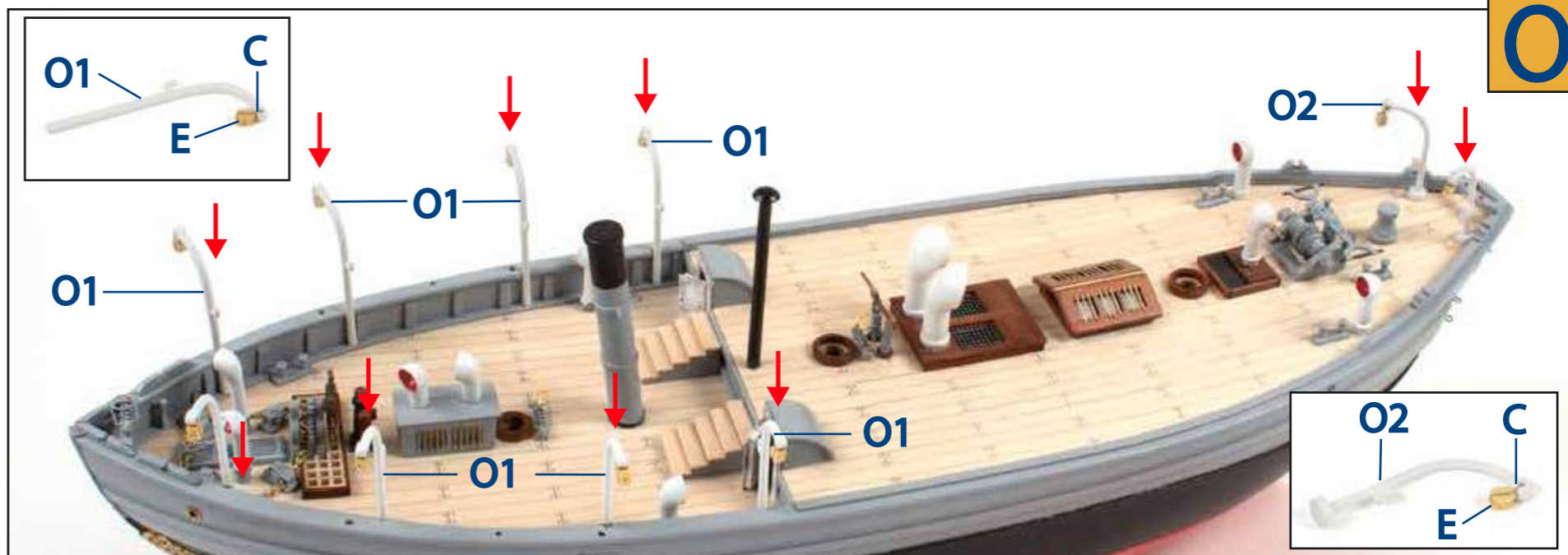
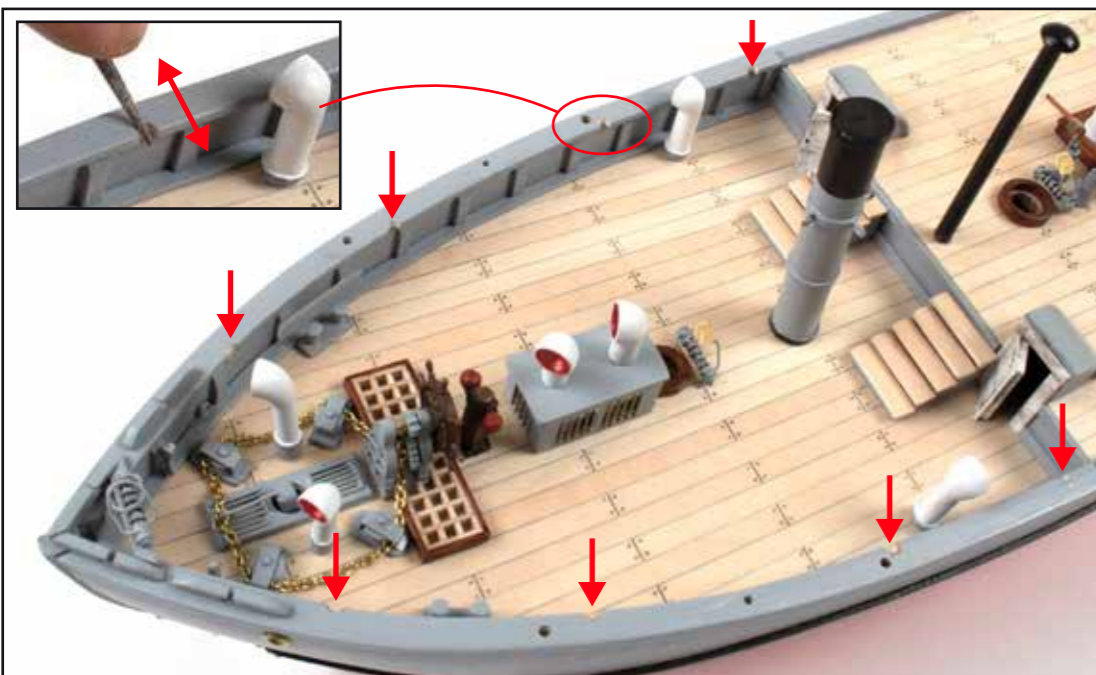

P

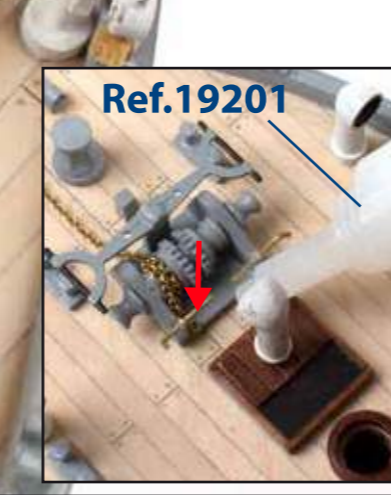
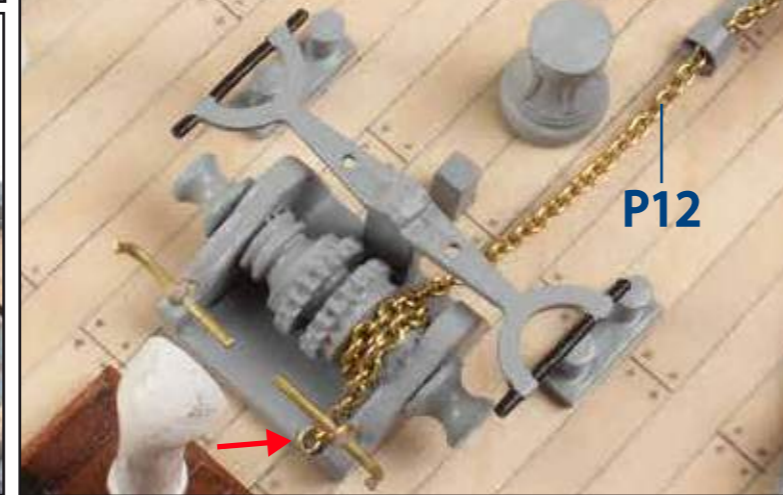
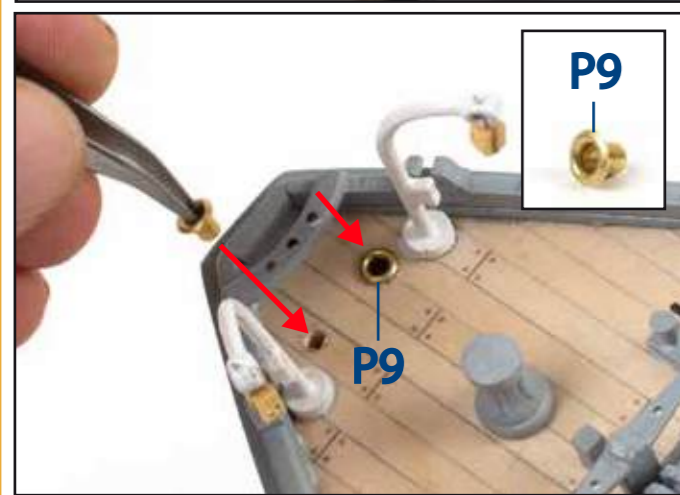
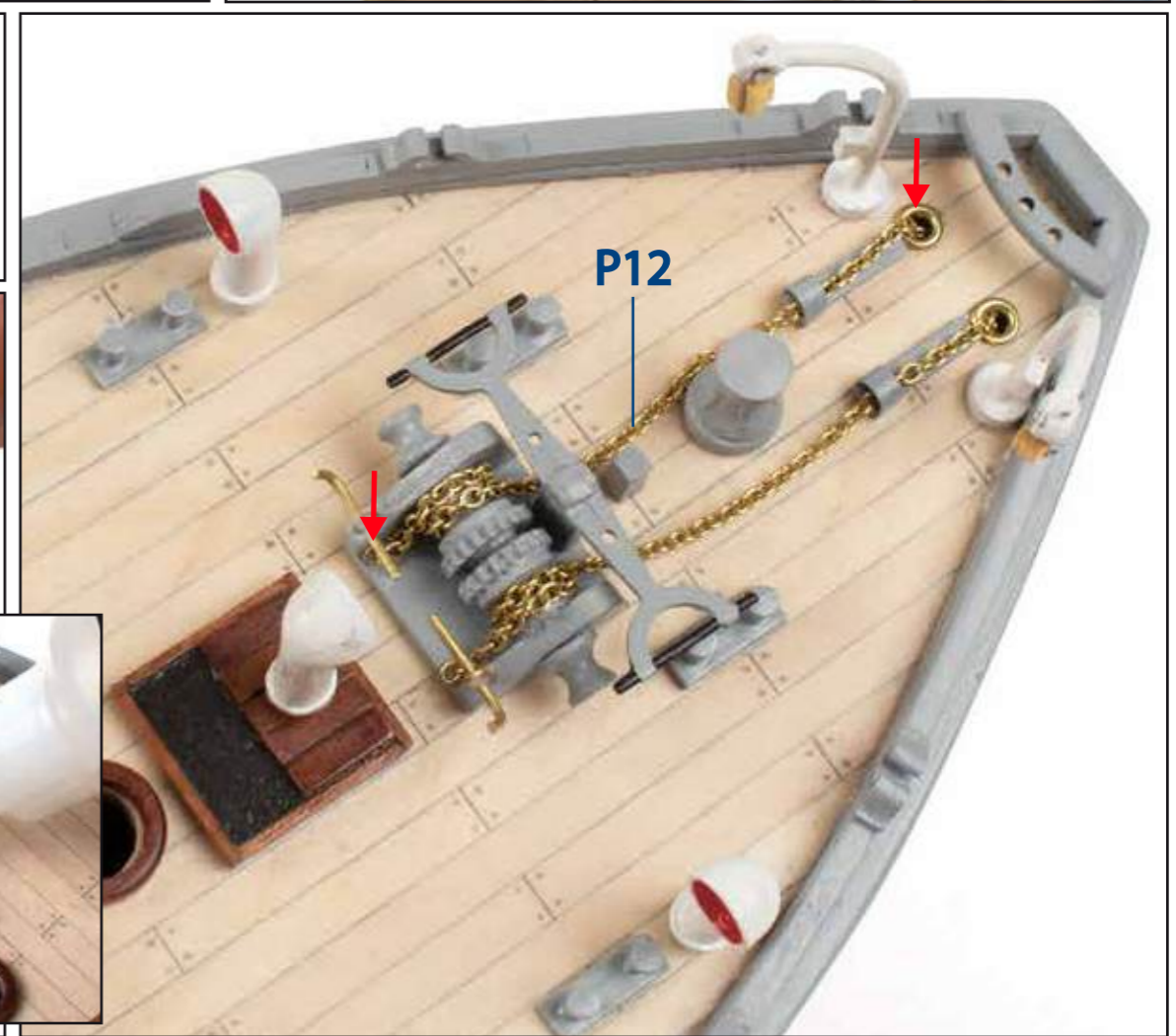
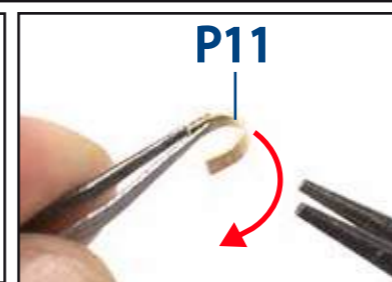
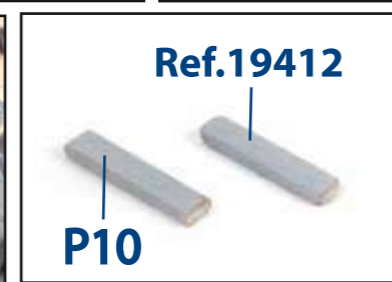
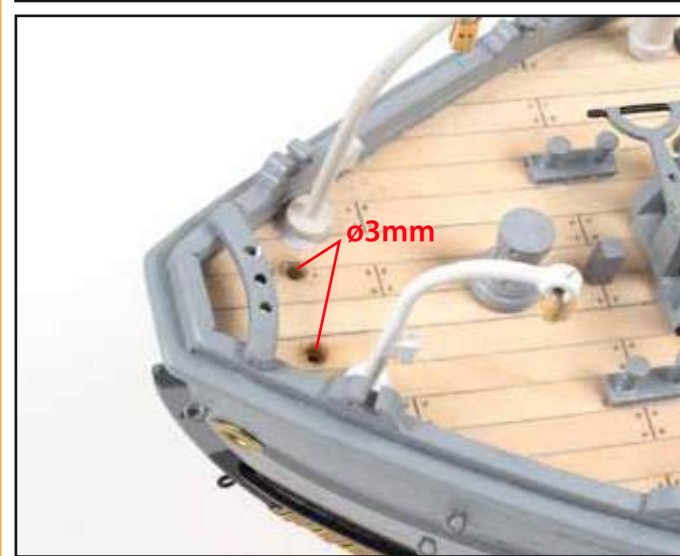
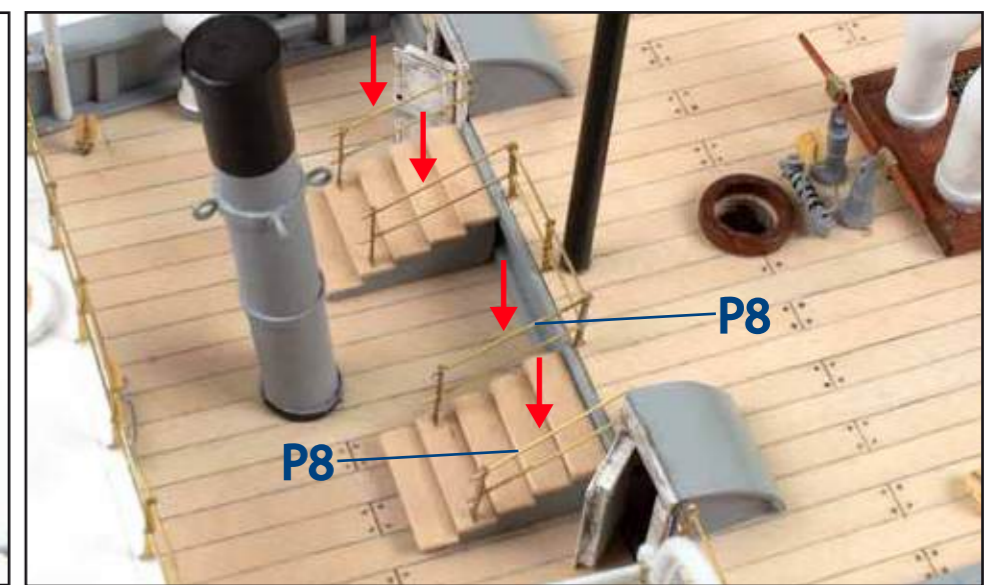
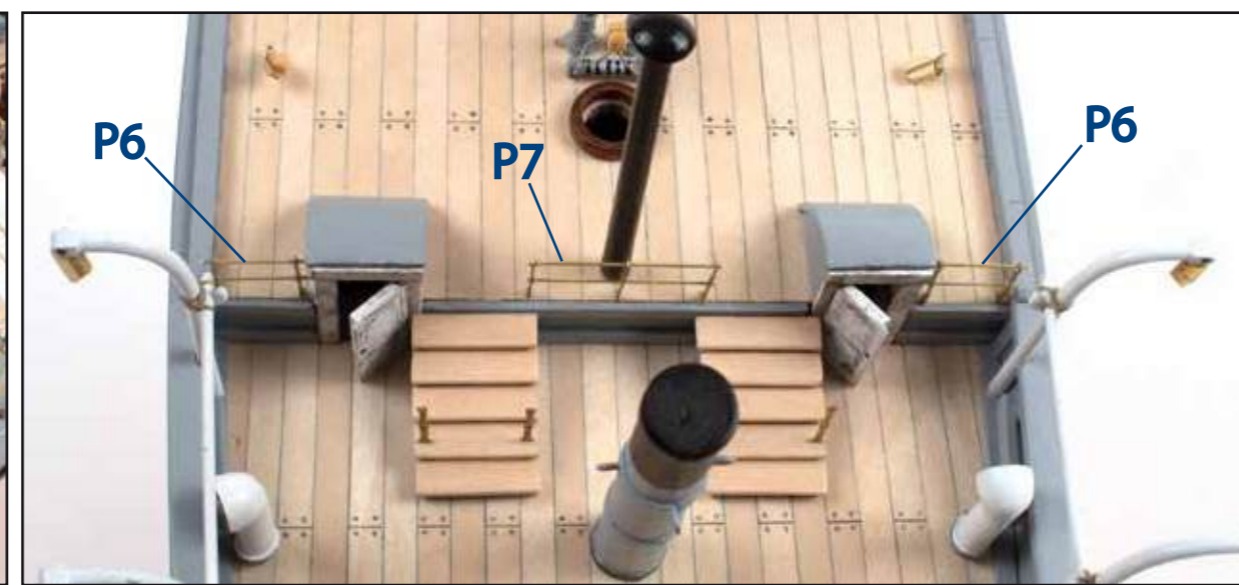
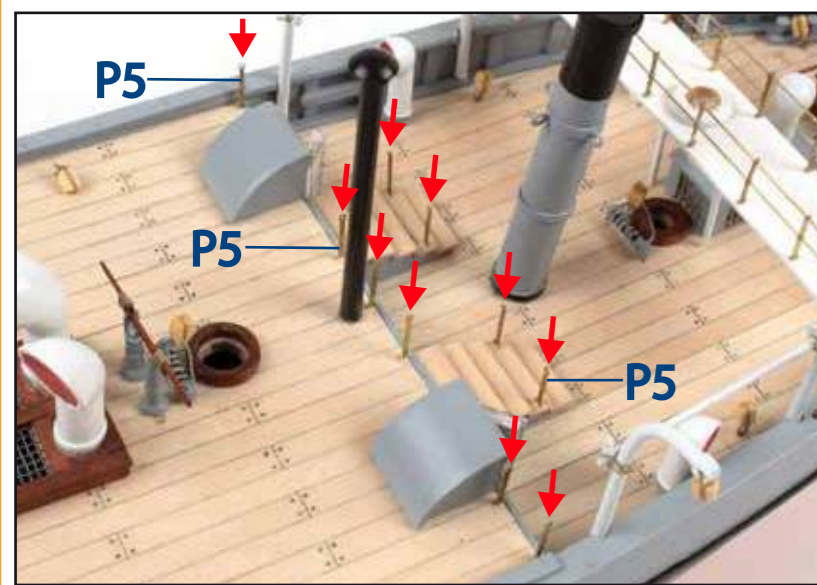
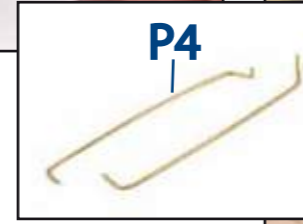
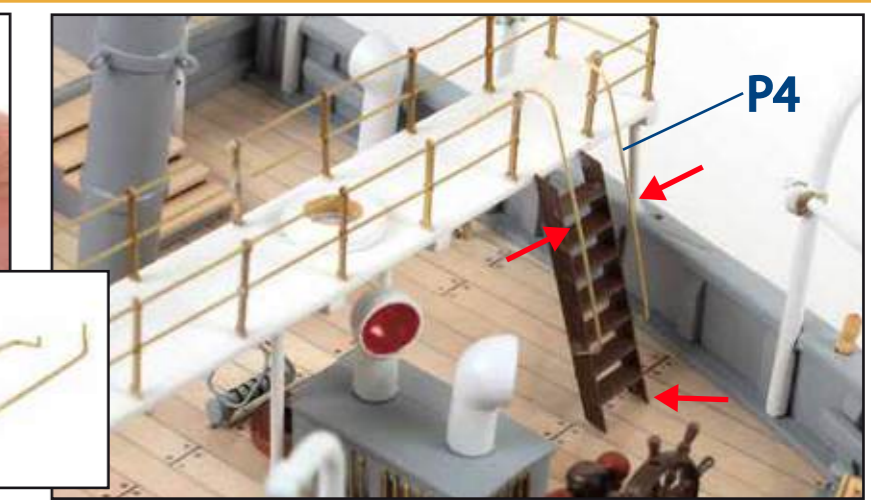
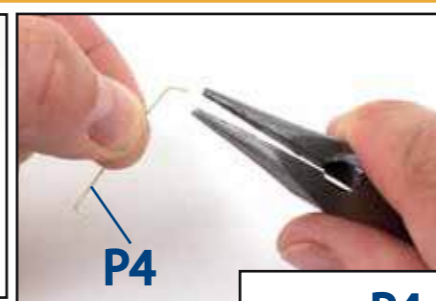
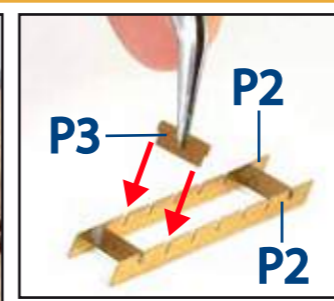
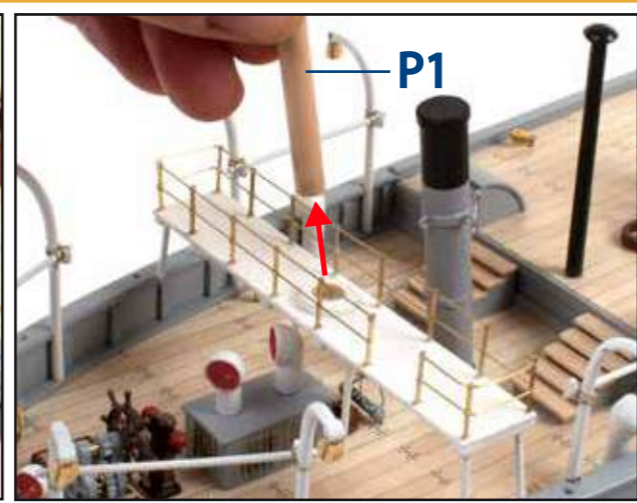
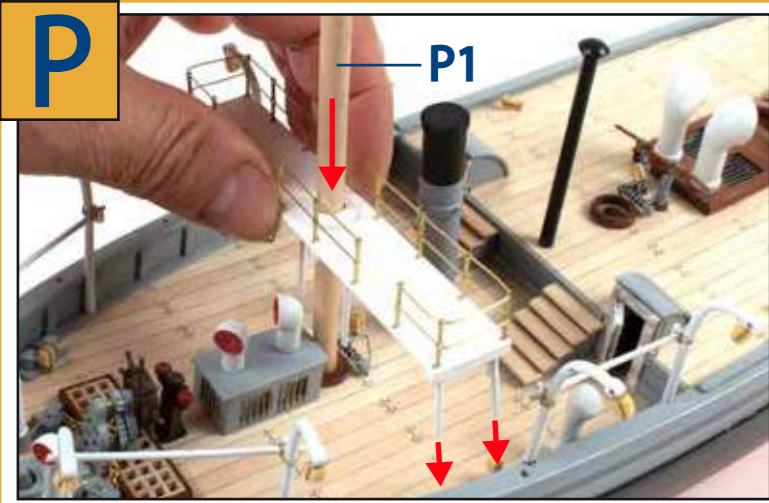

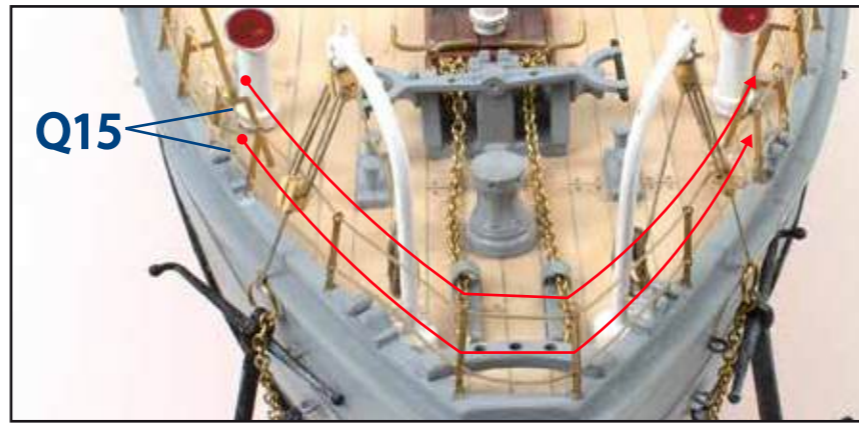
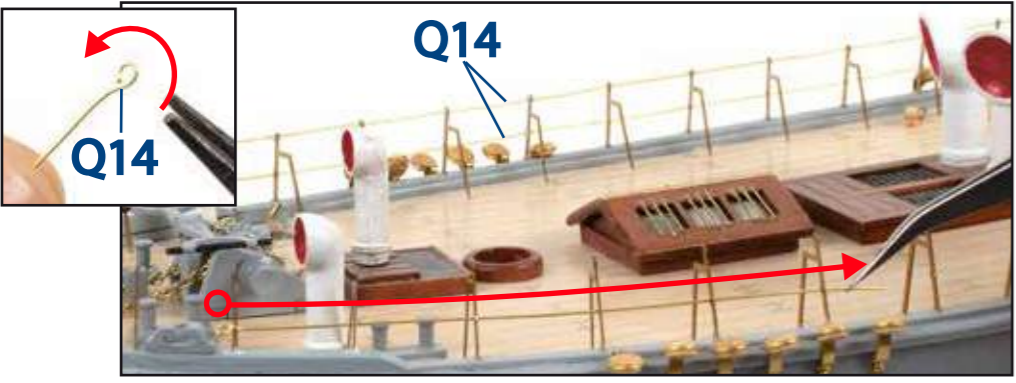
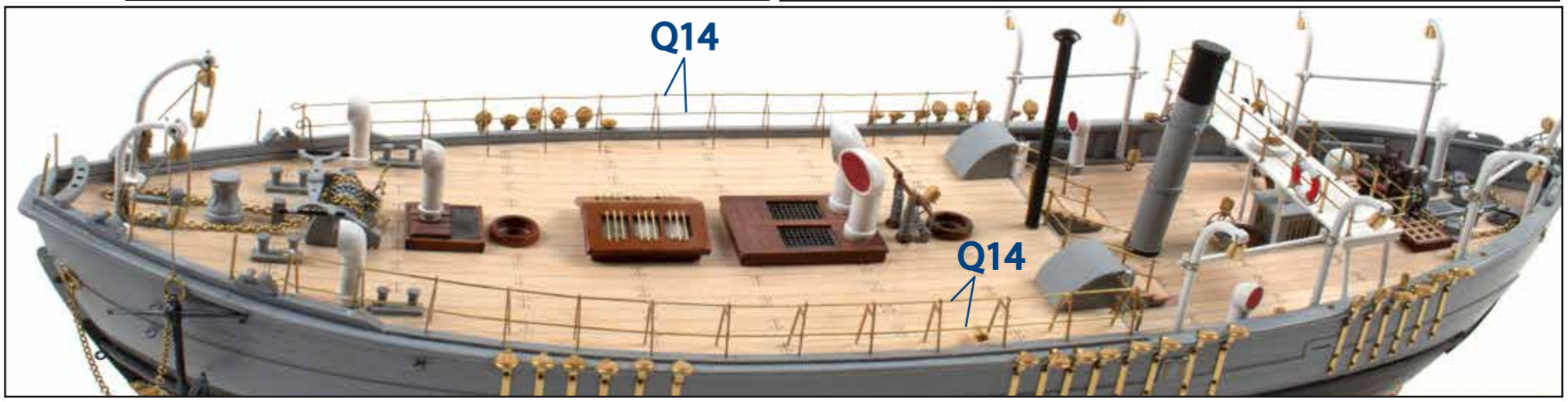
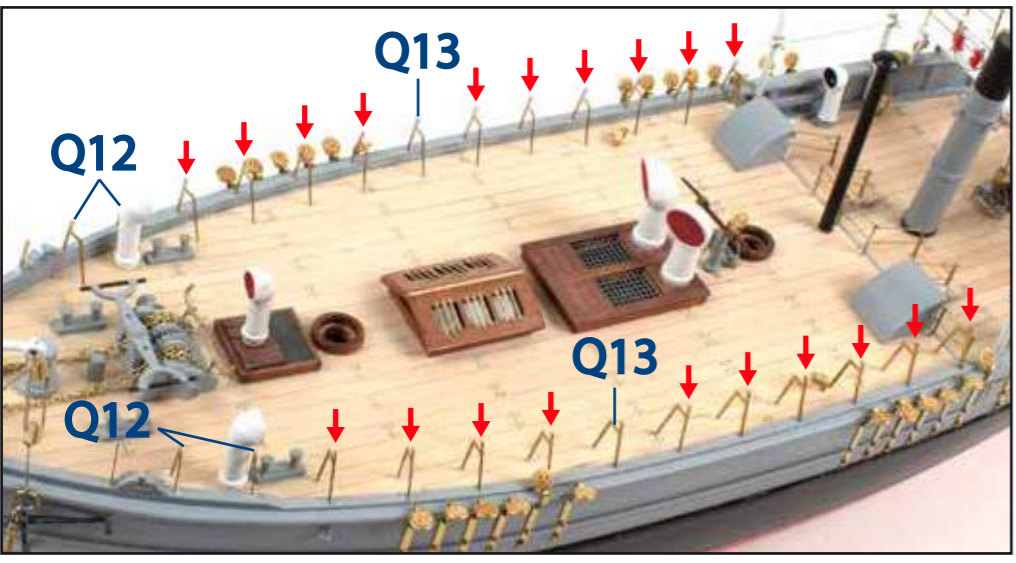
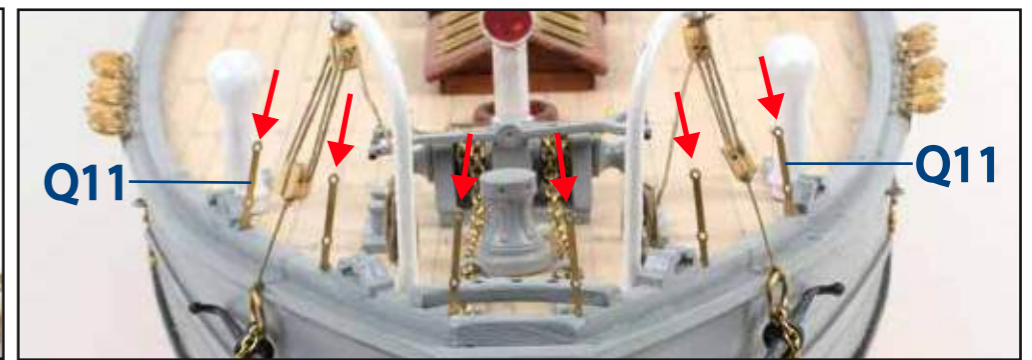
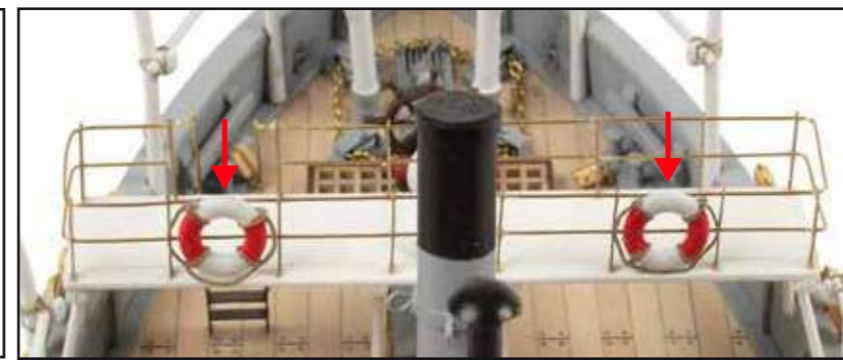
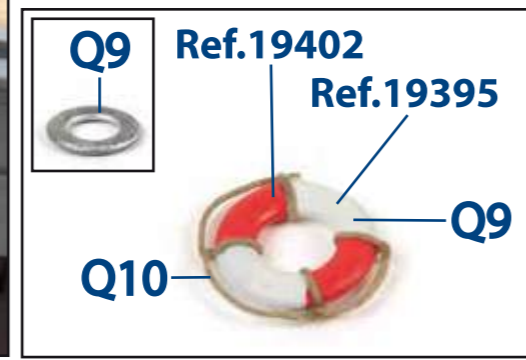
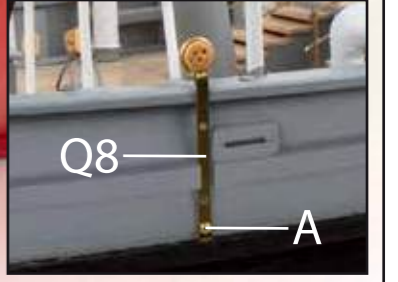
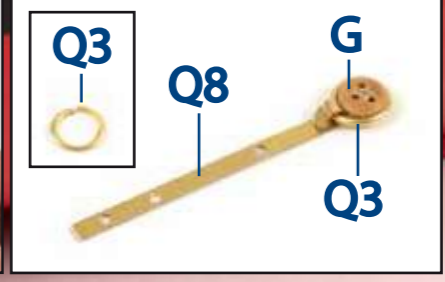
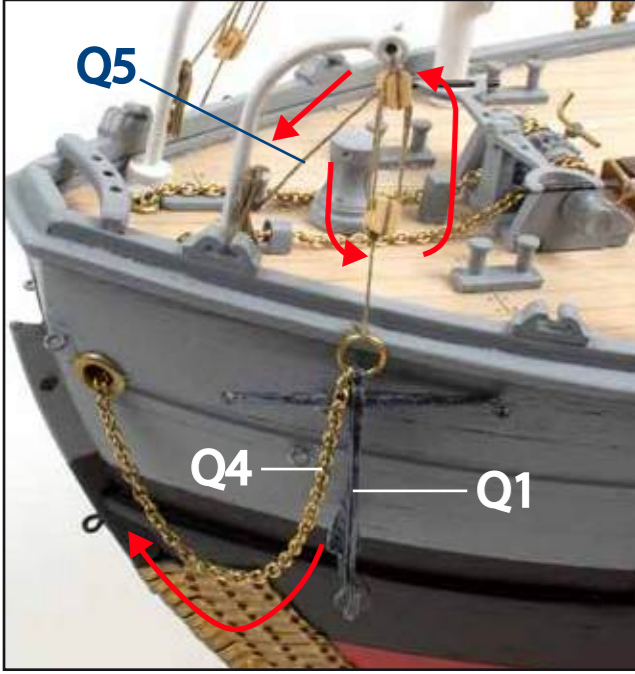
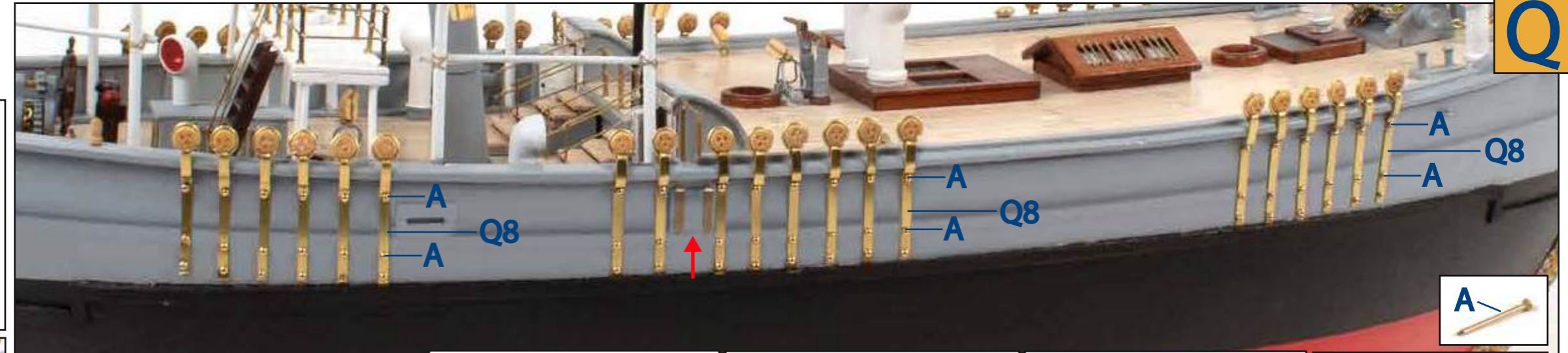
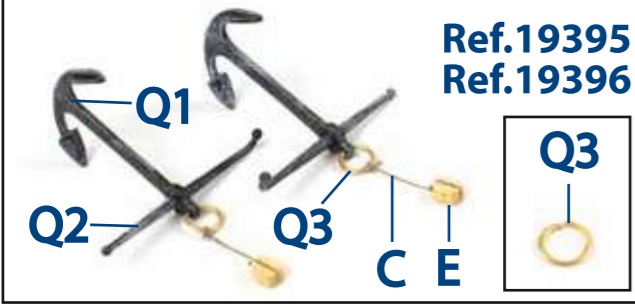
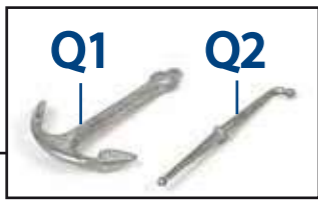

R

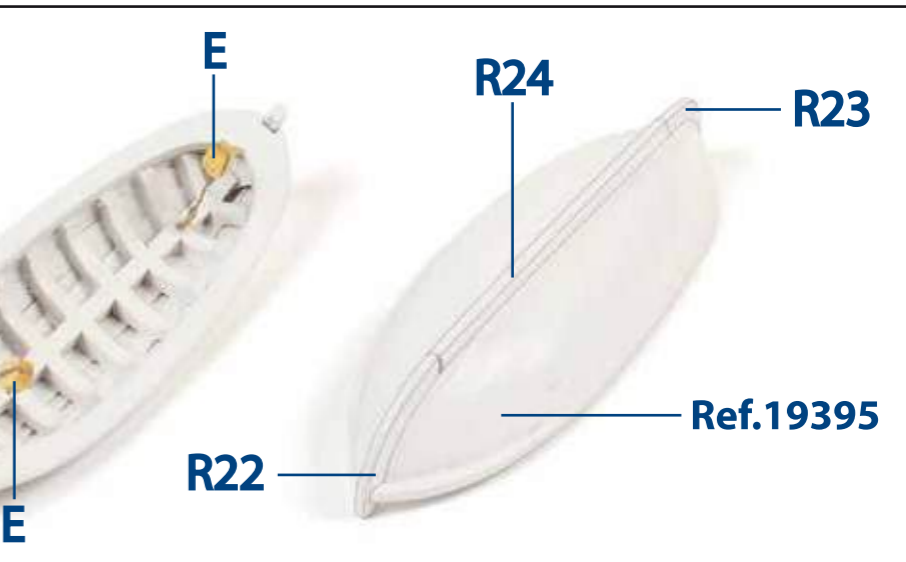
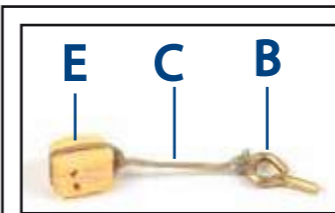
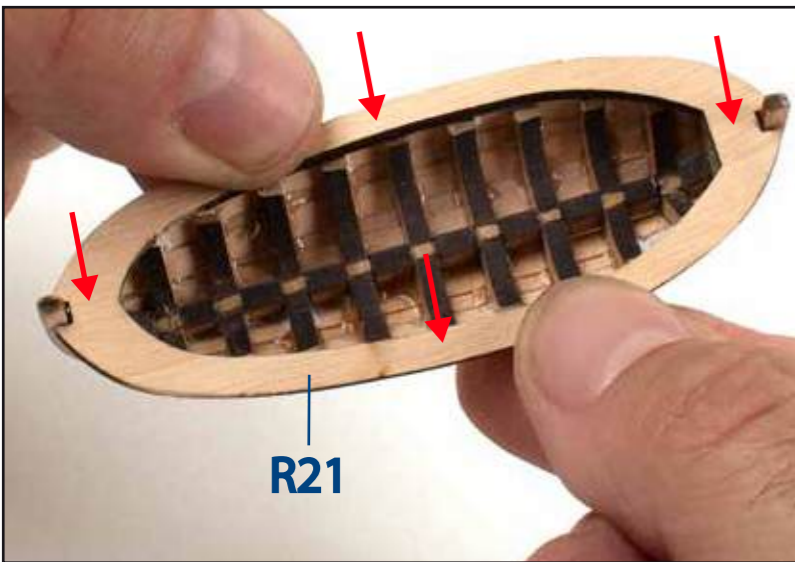
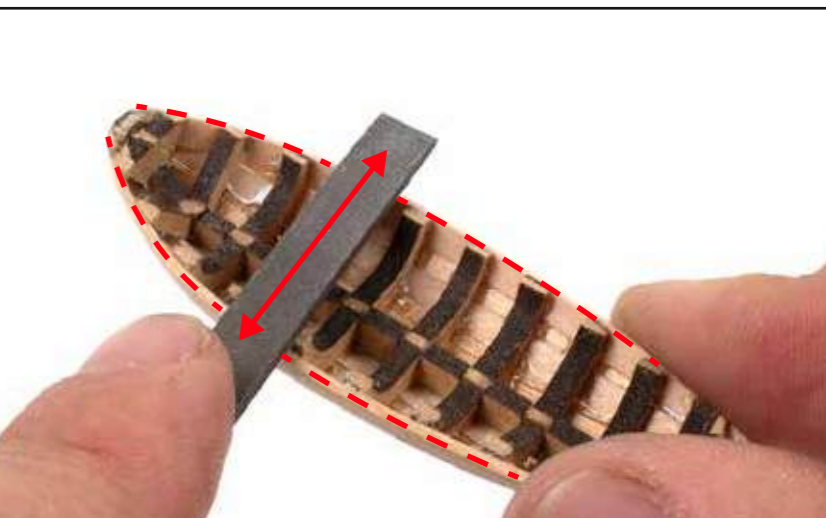
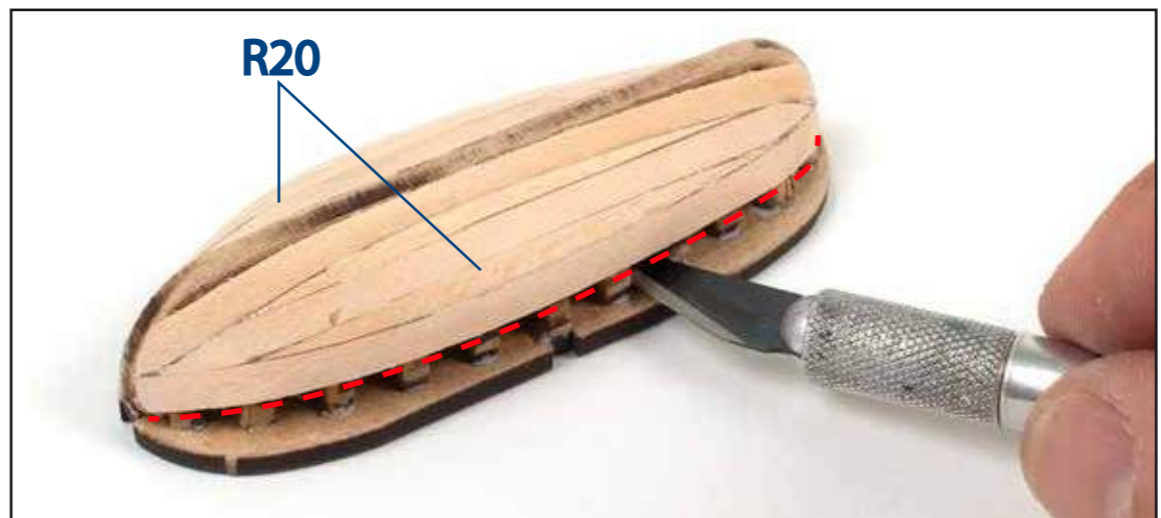
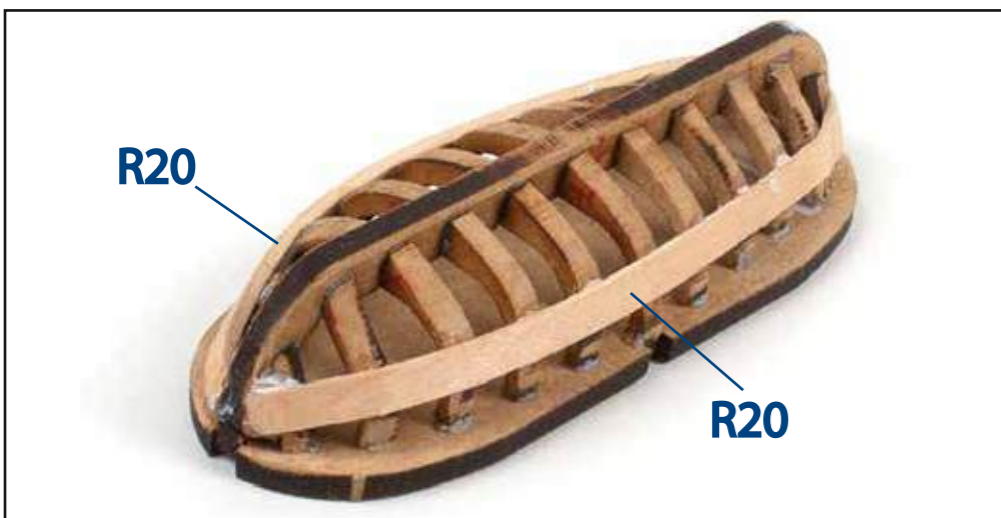
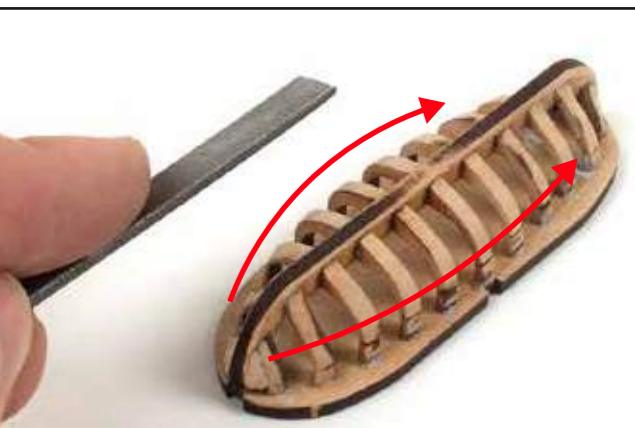
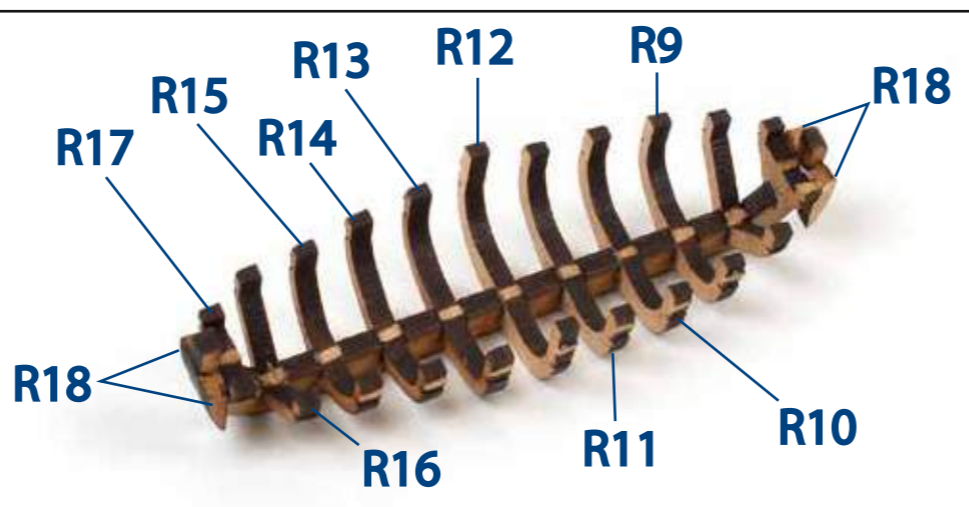
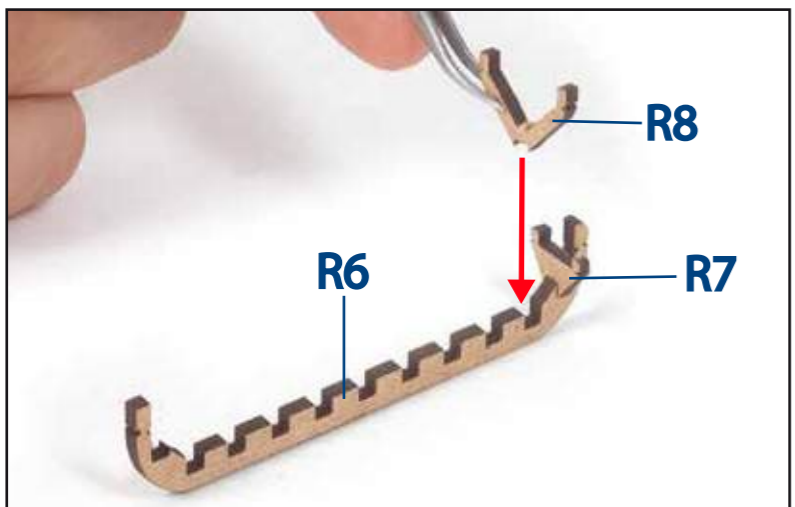
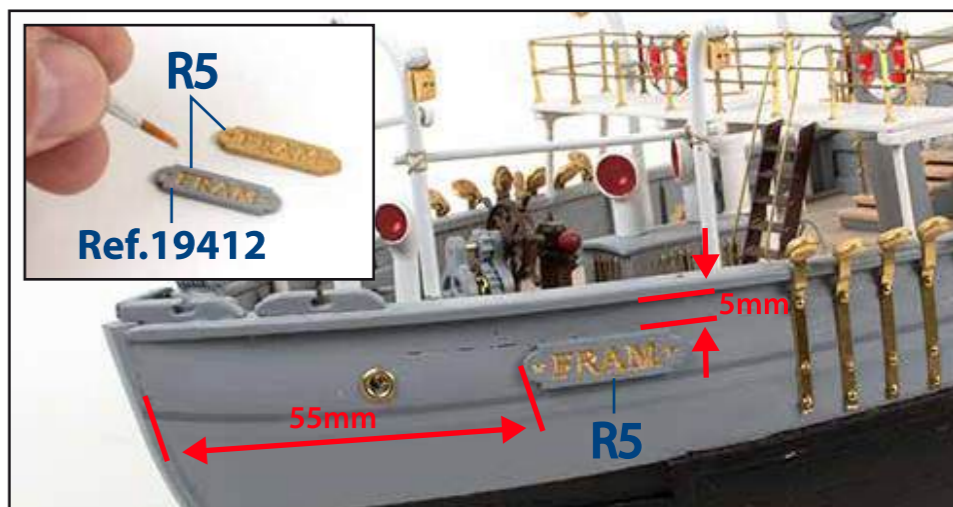
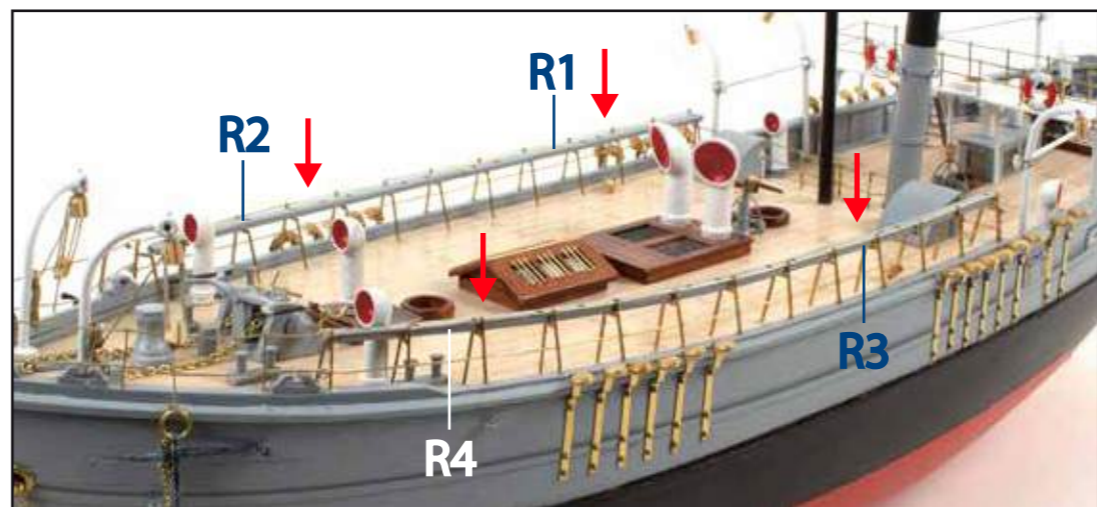
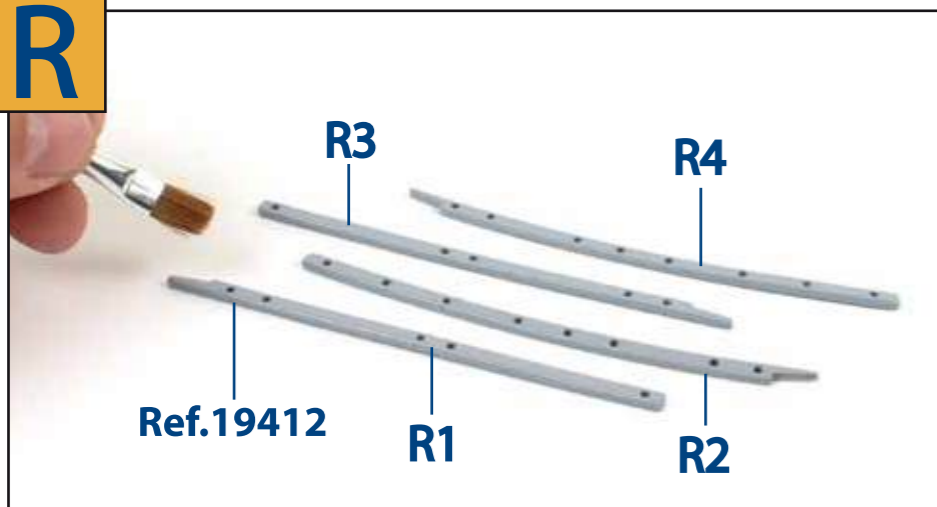

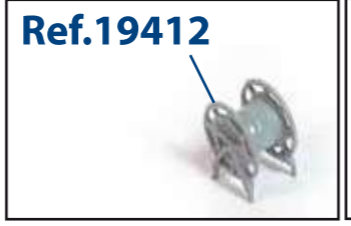
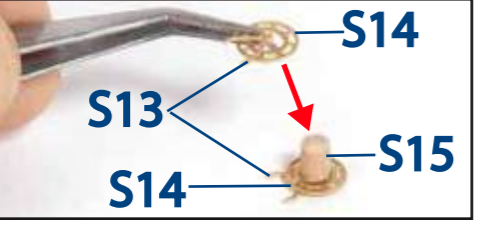
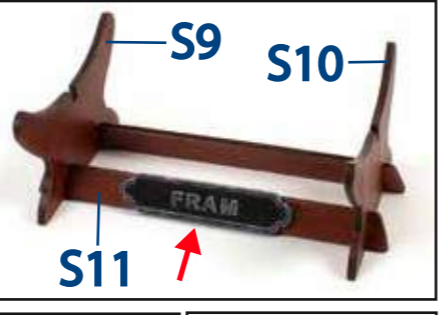
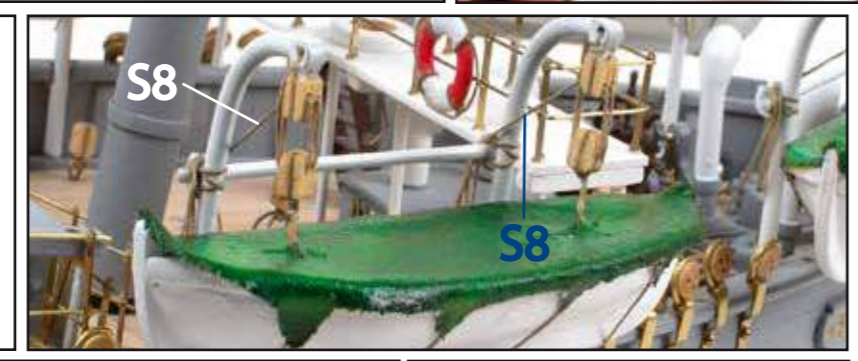
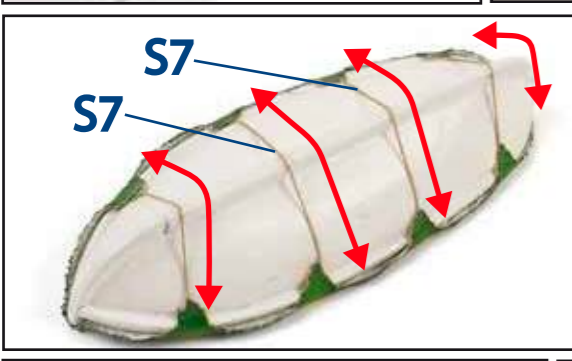
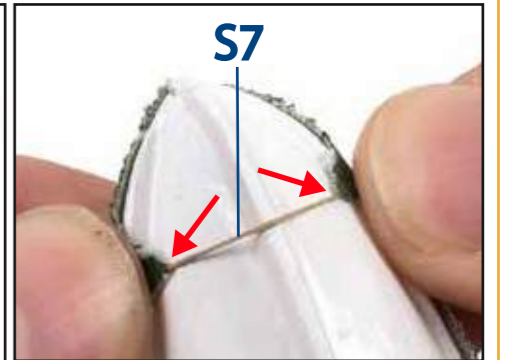
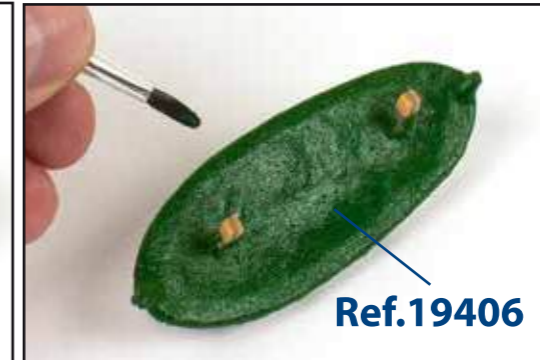
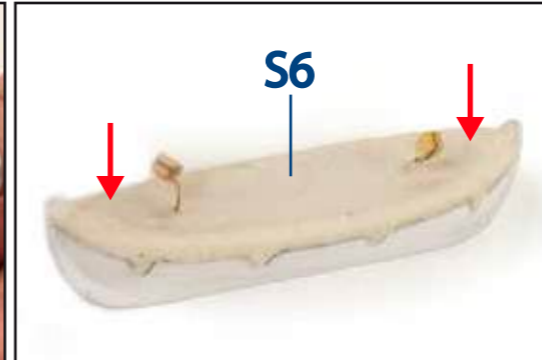
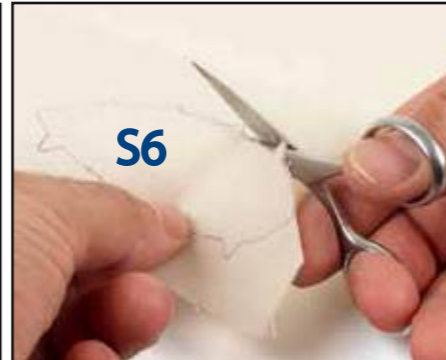
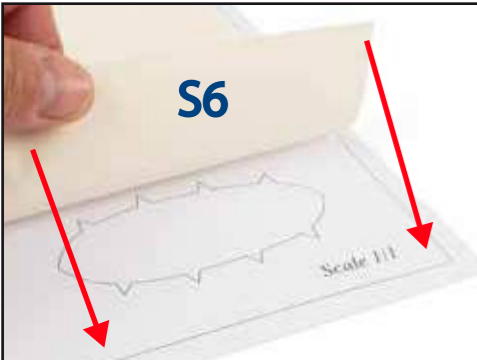
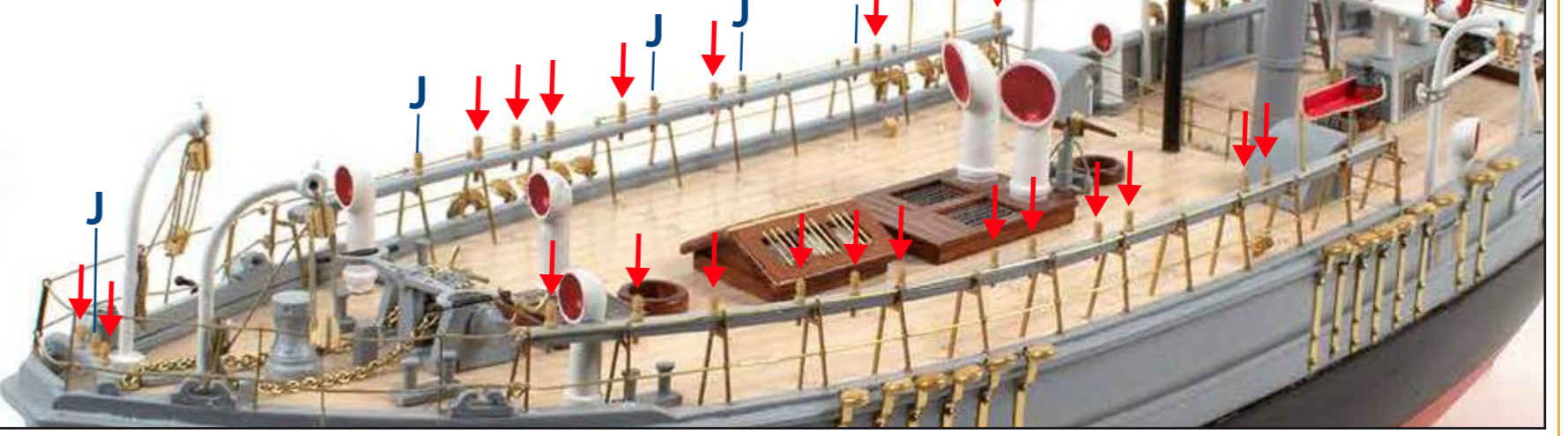
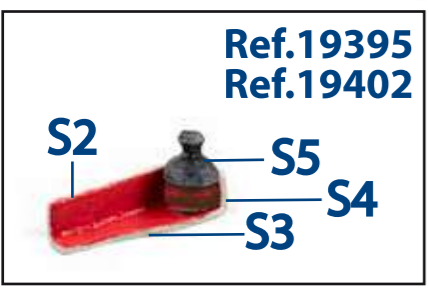
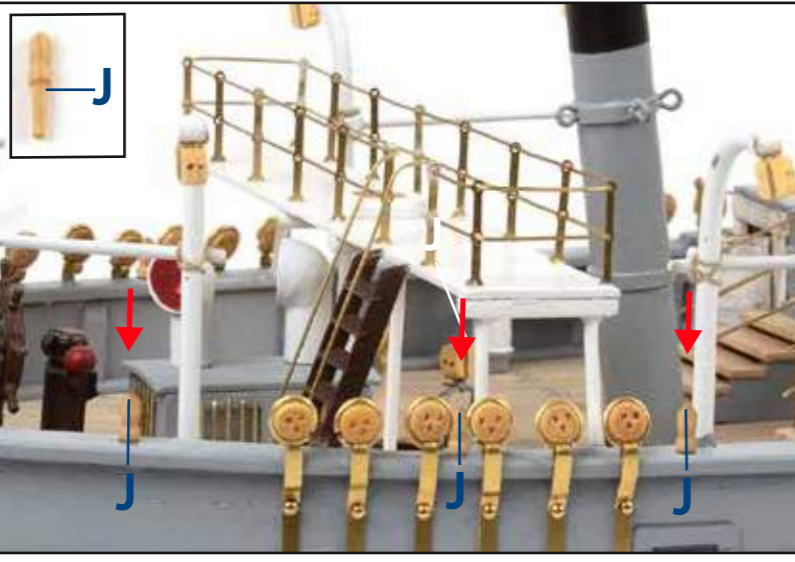
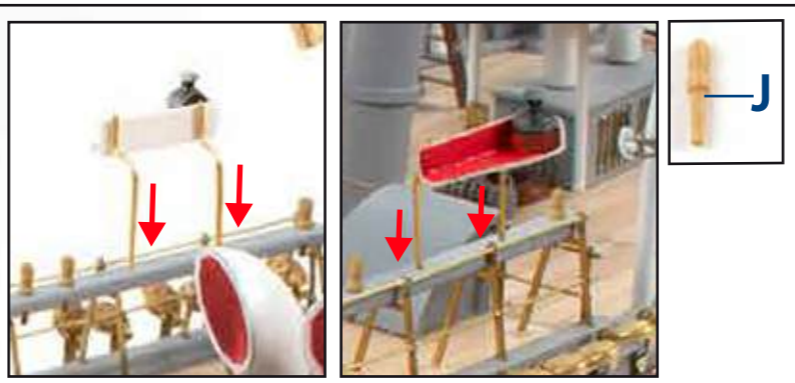
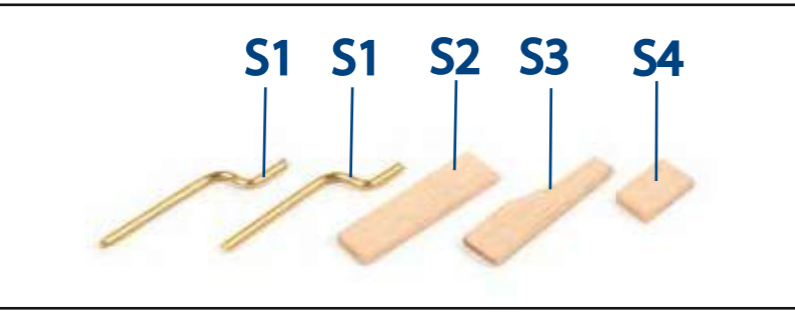
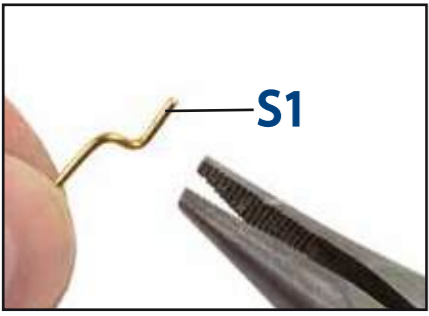

T

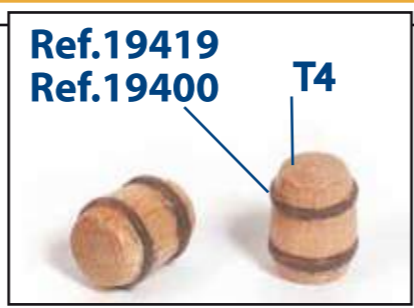
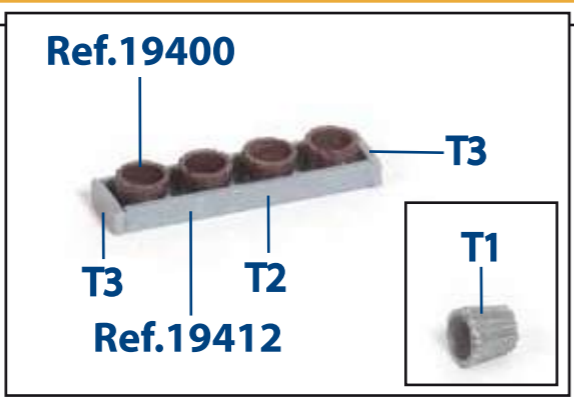

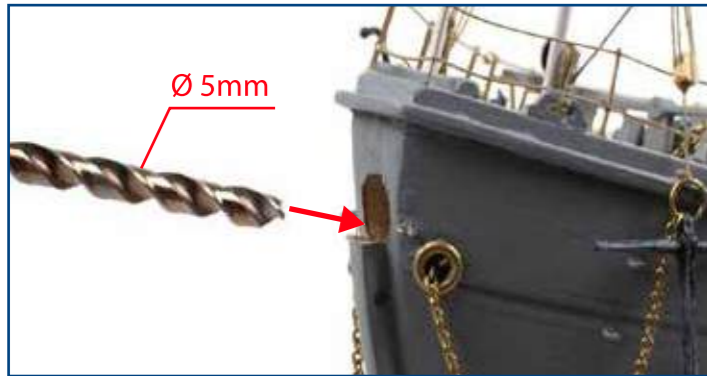
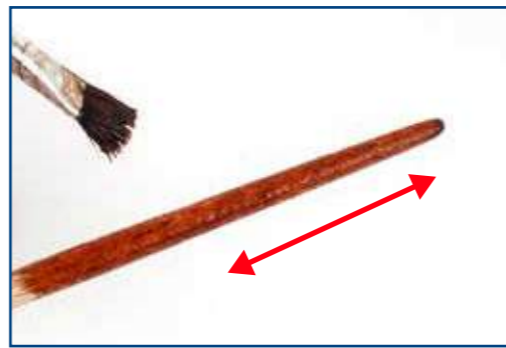
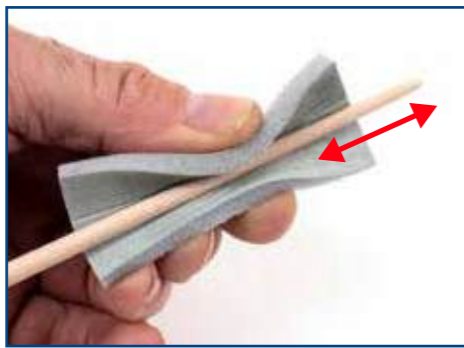
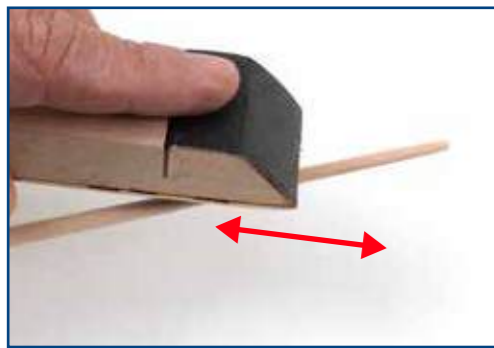

Consultar los planos de mastiles
 Consult the masts drawings
 Consulte os desenhos dos mastros
 Consulter les dessins des mâts
 Konsultieren Sie die Mastenzeichnungen
 Обратитесь к рисункам мачы
 Consultare i disegni degli alberi

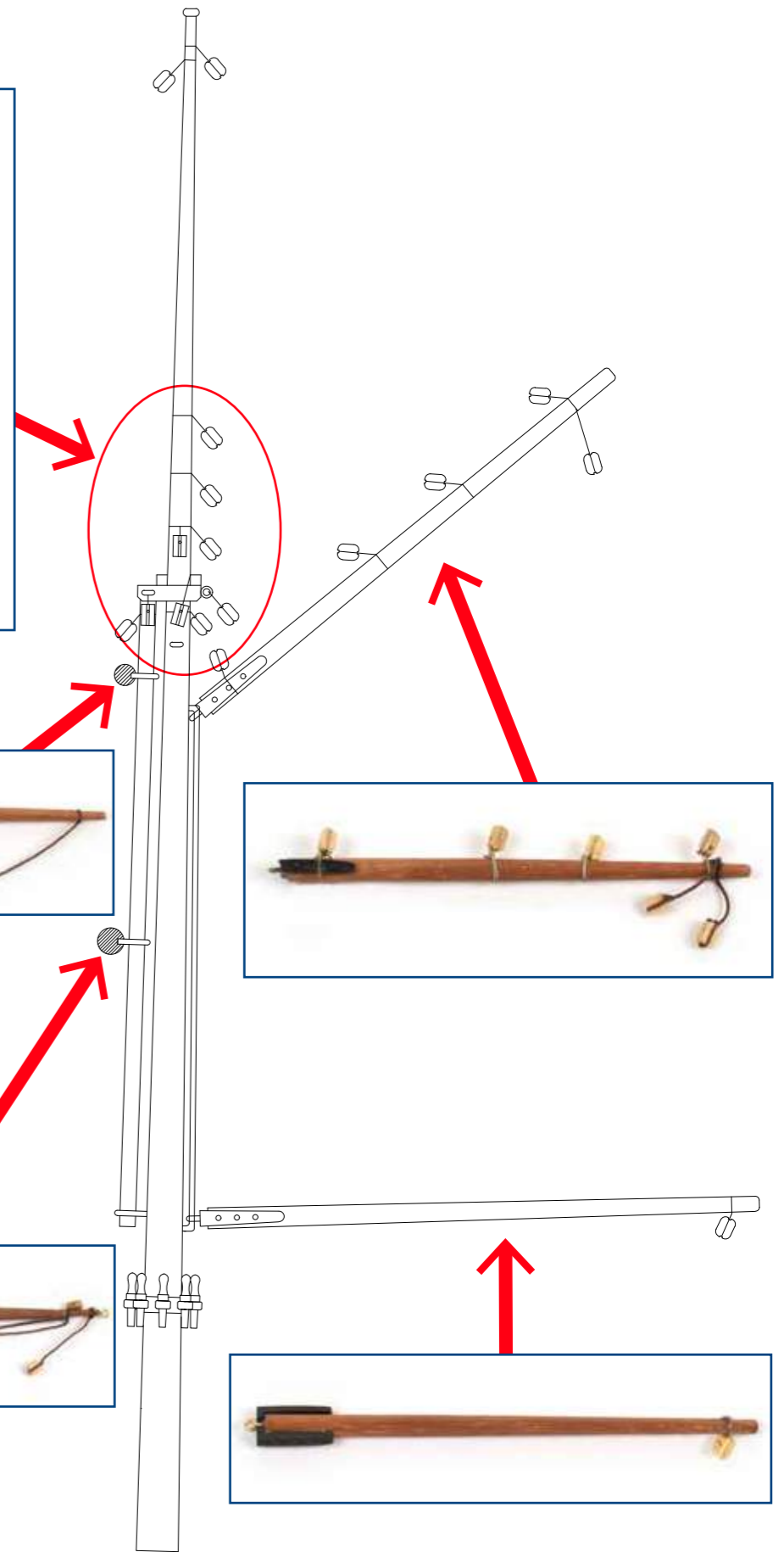
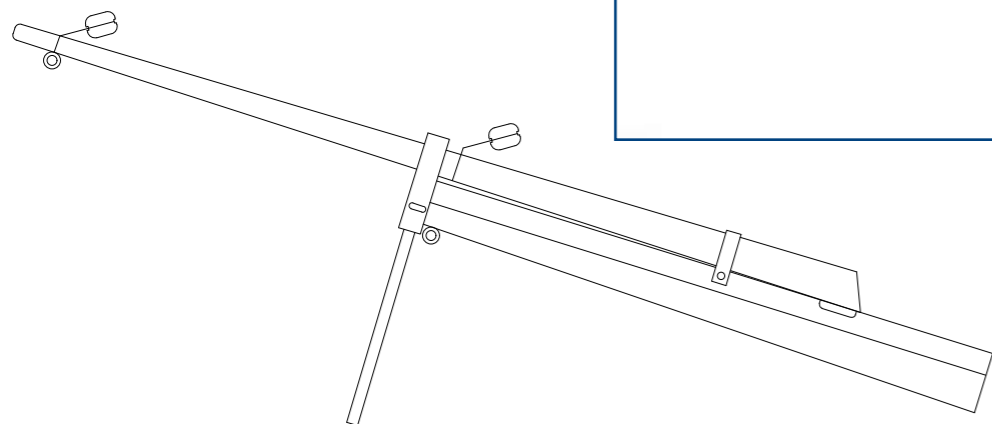

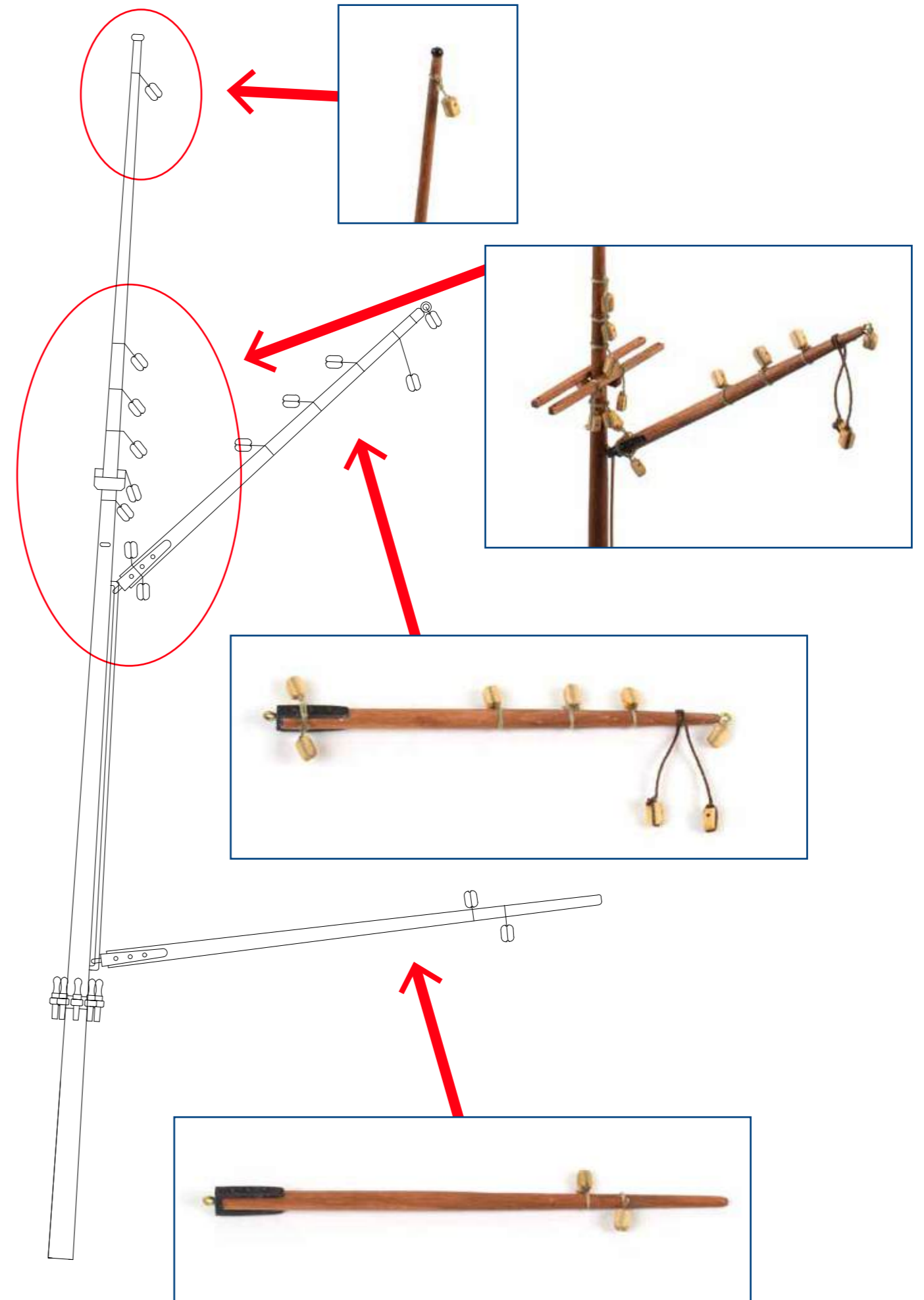
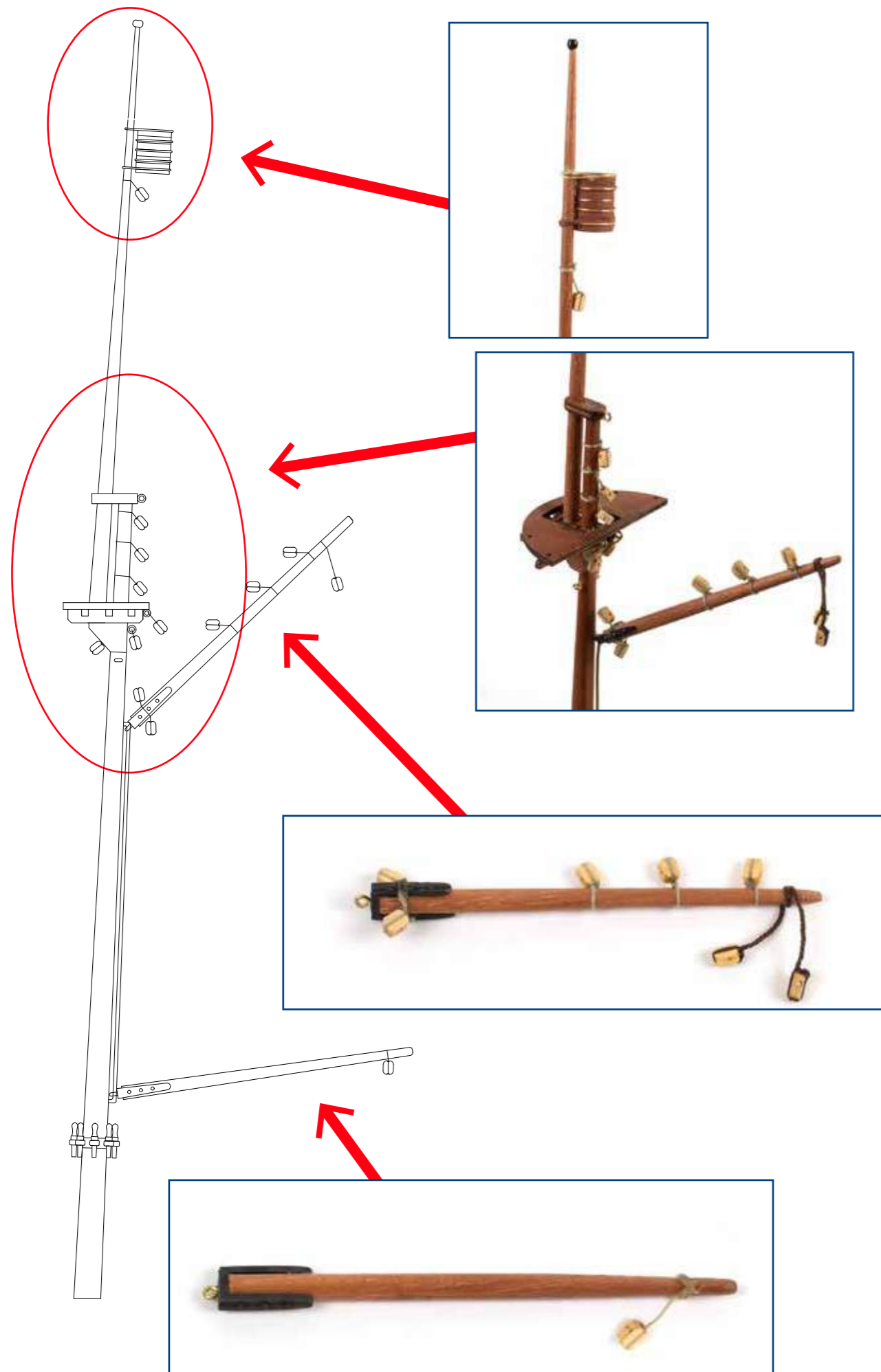

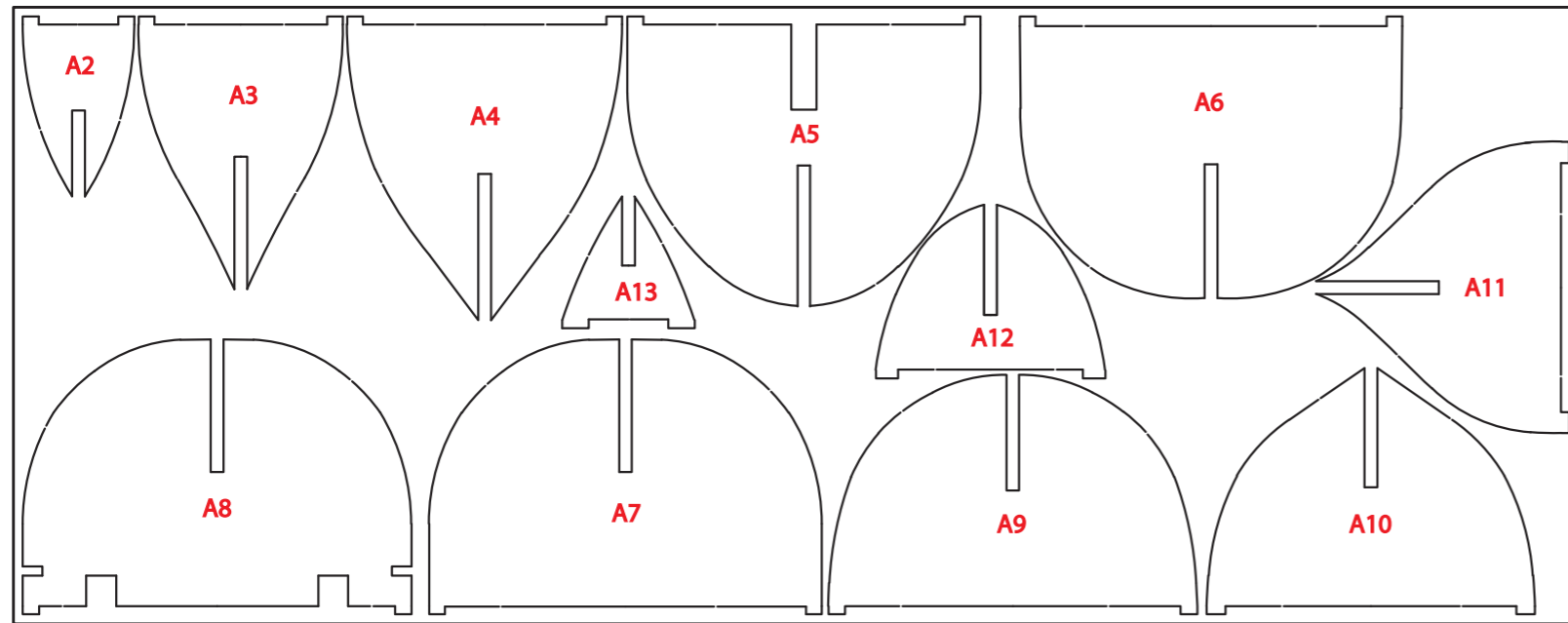

12011-2

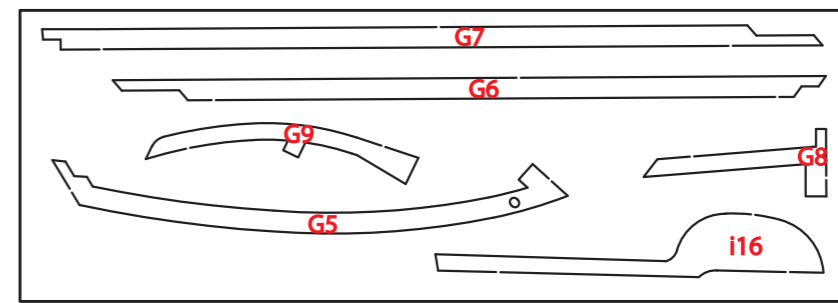

12011-6

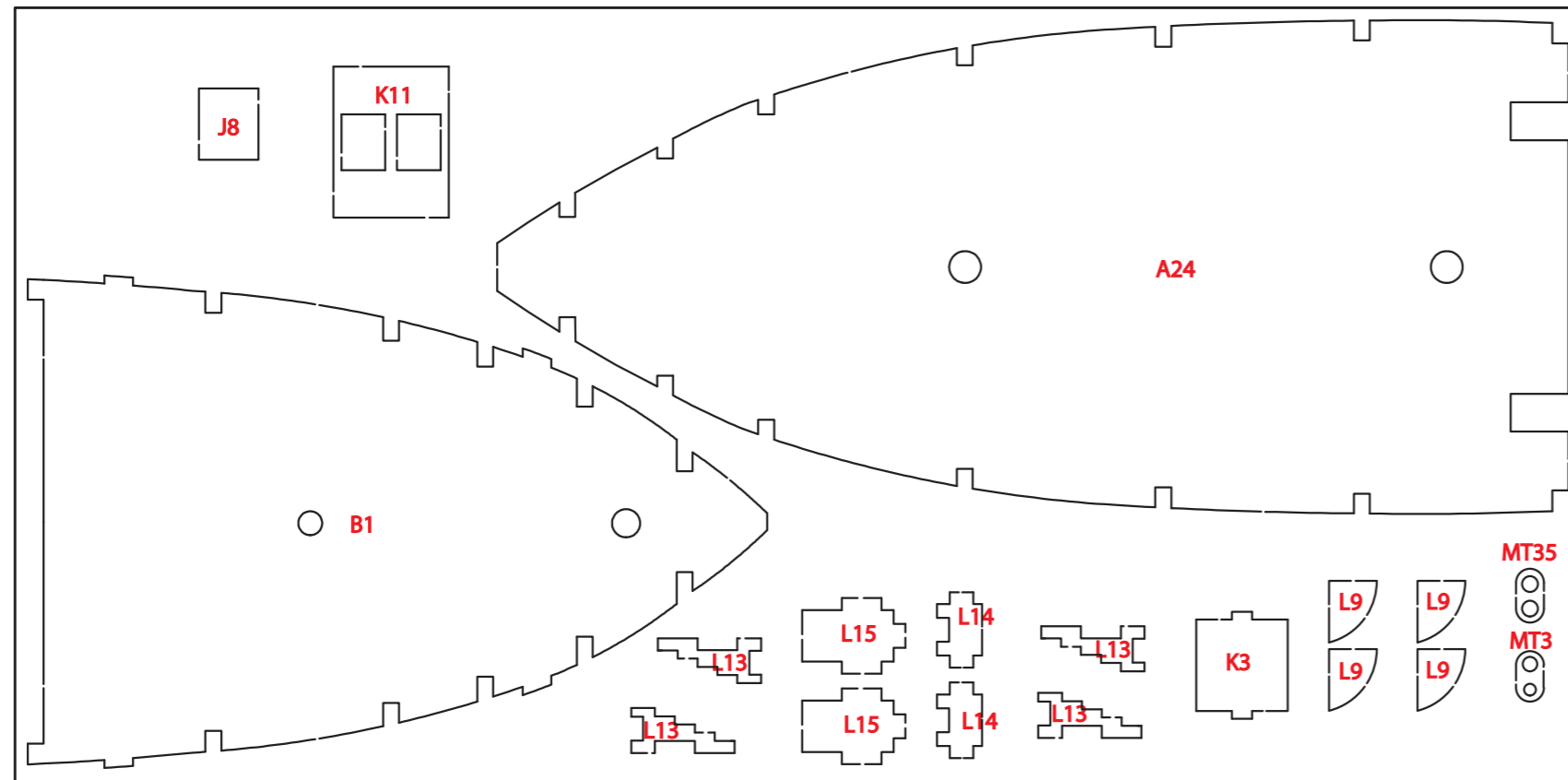

12011-4

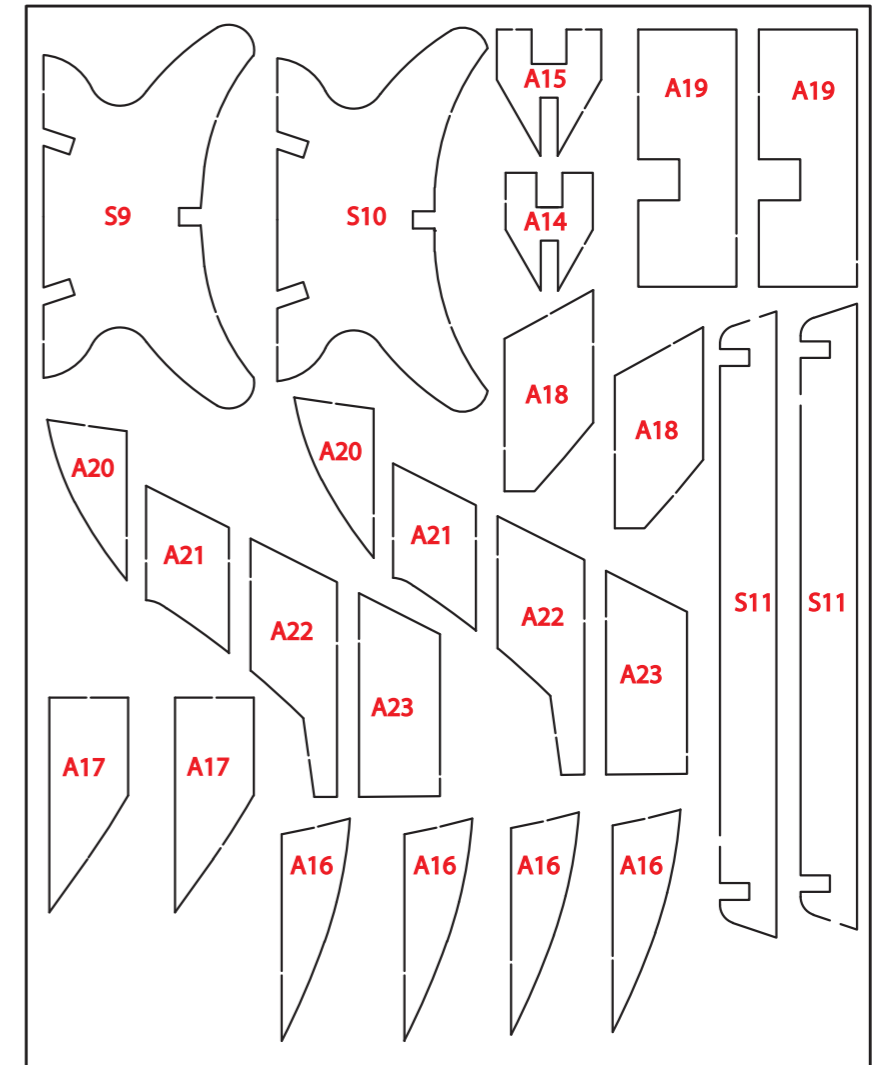

12011-3

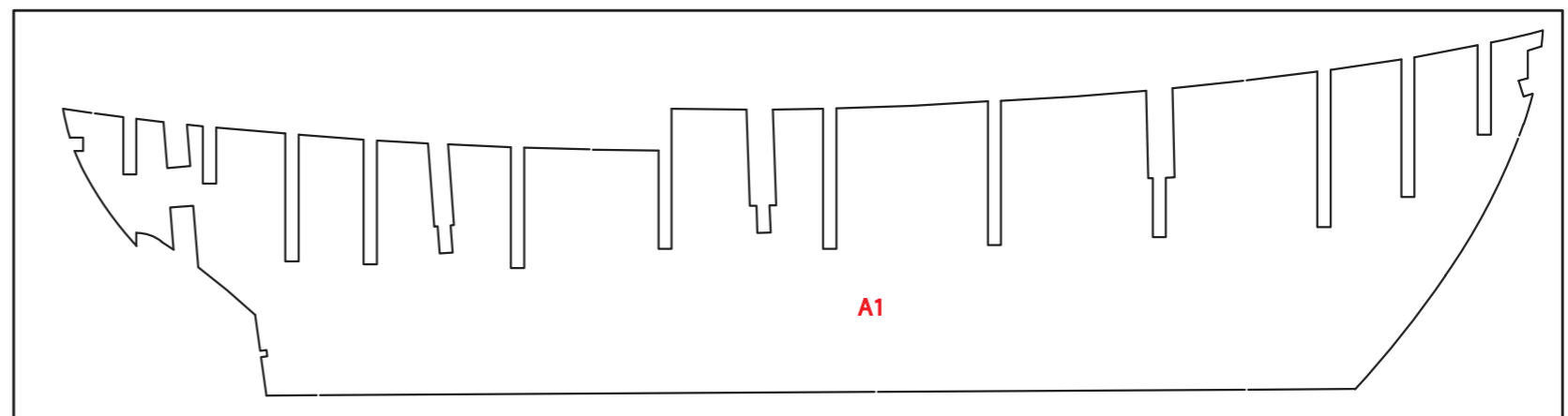

12011-1



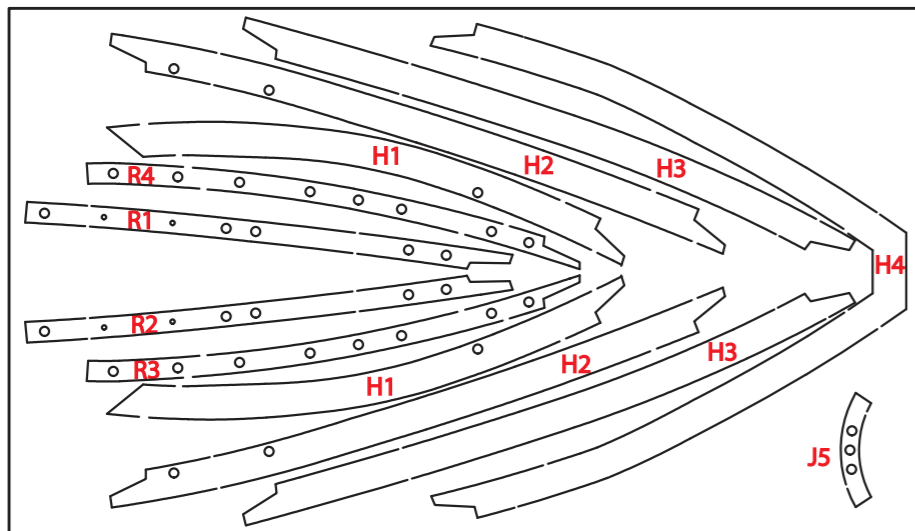

12011-7

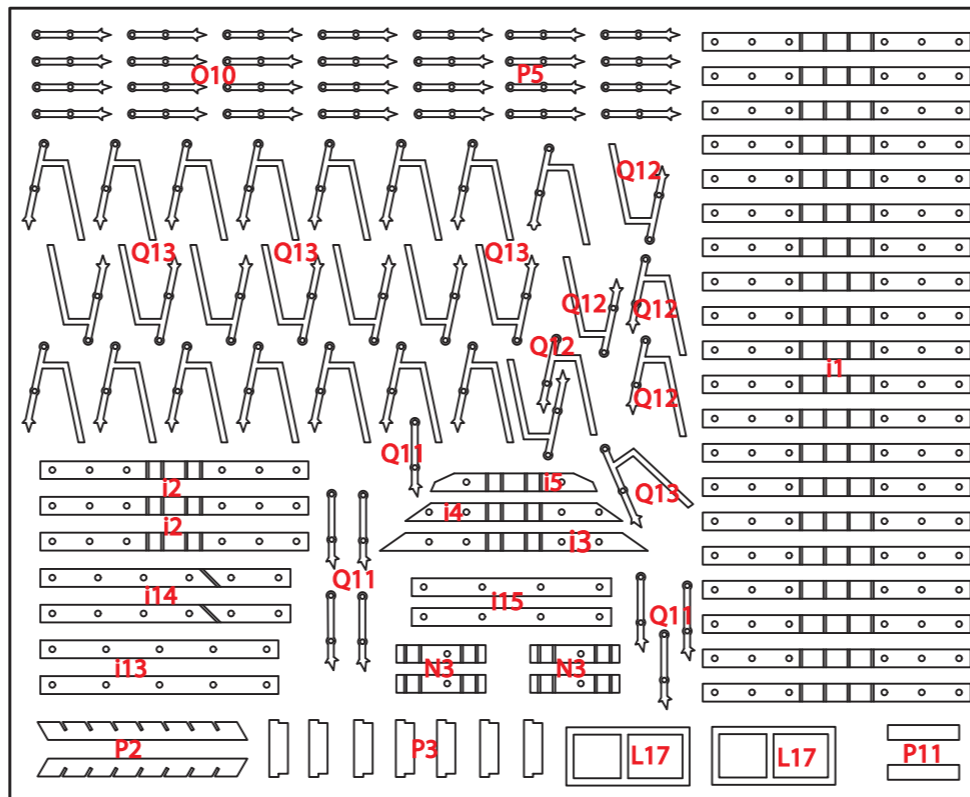

12011-9

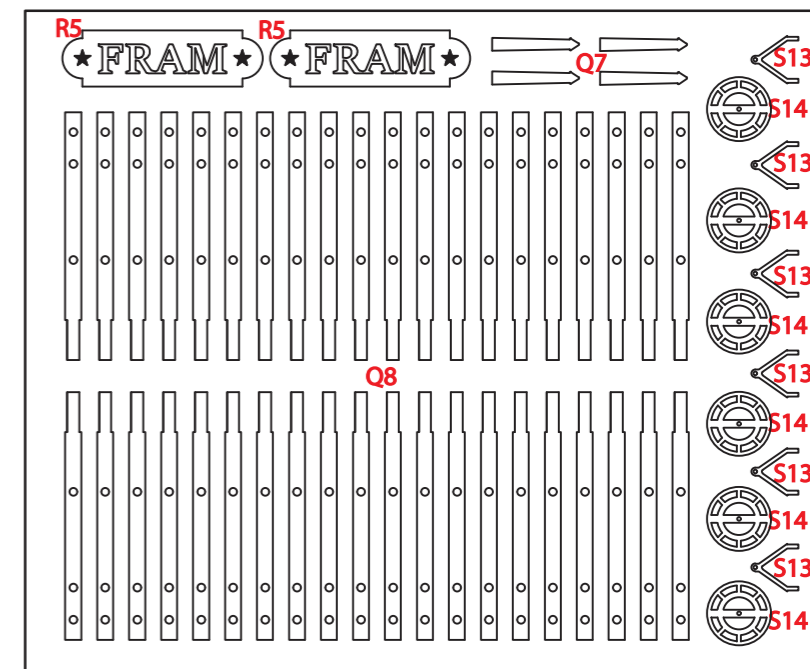

12011-10

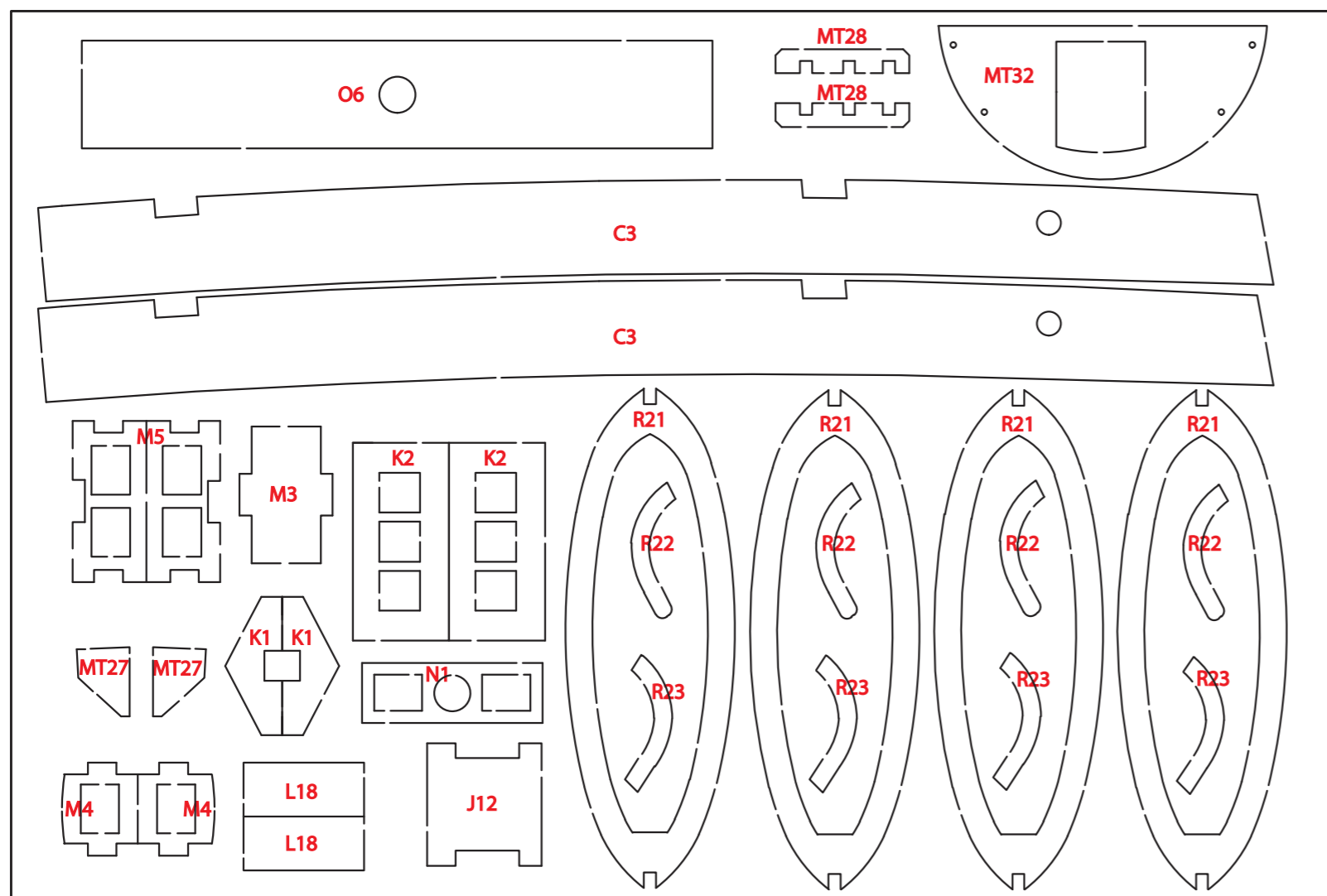

12011-5

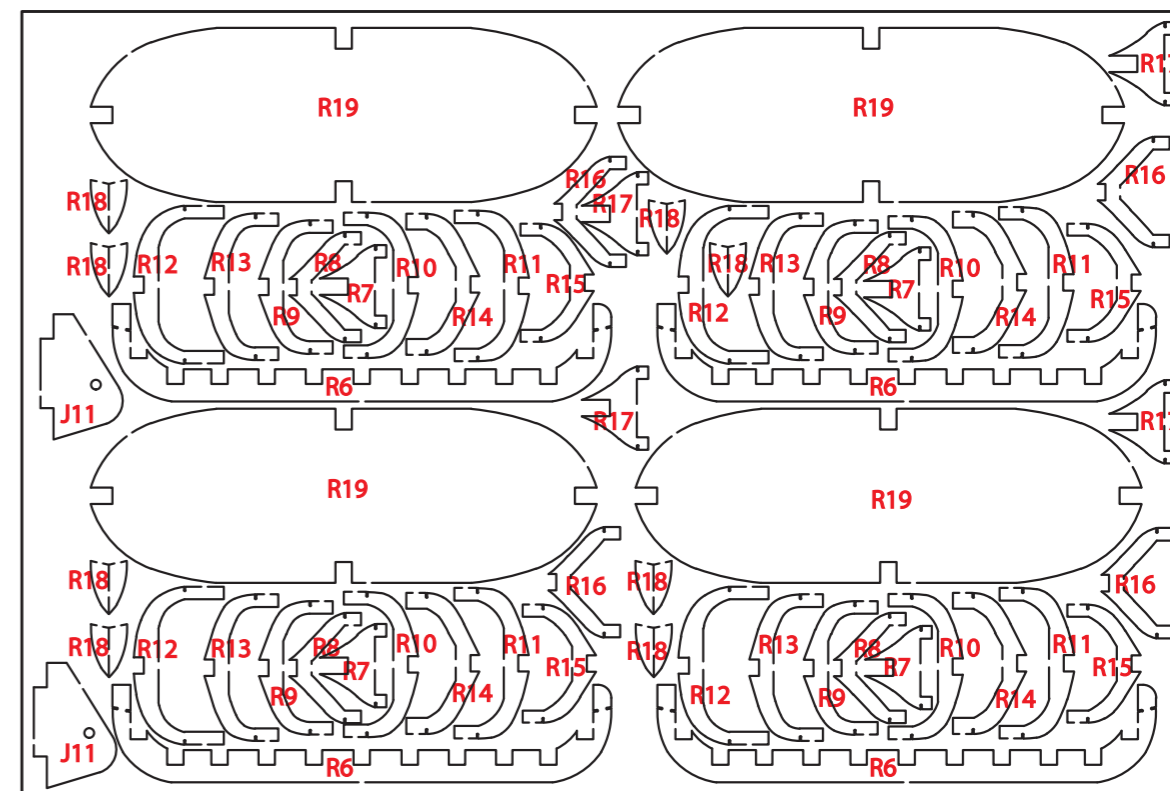

12011-8

Fram PL-01

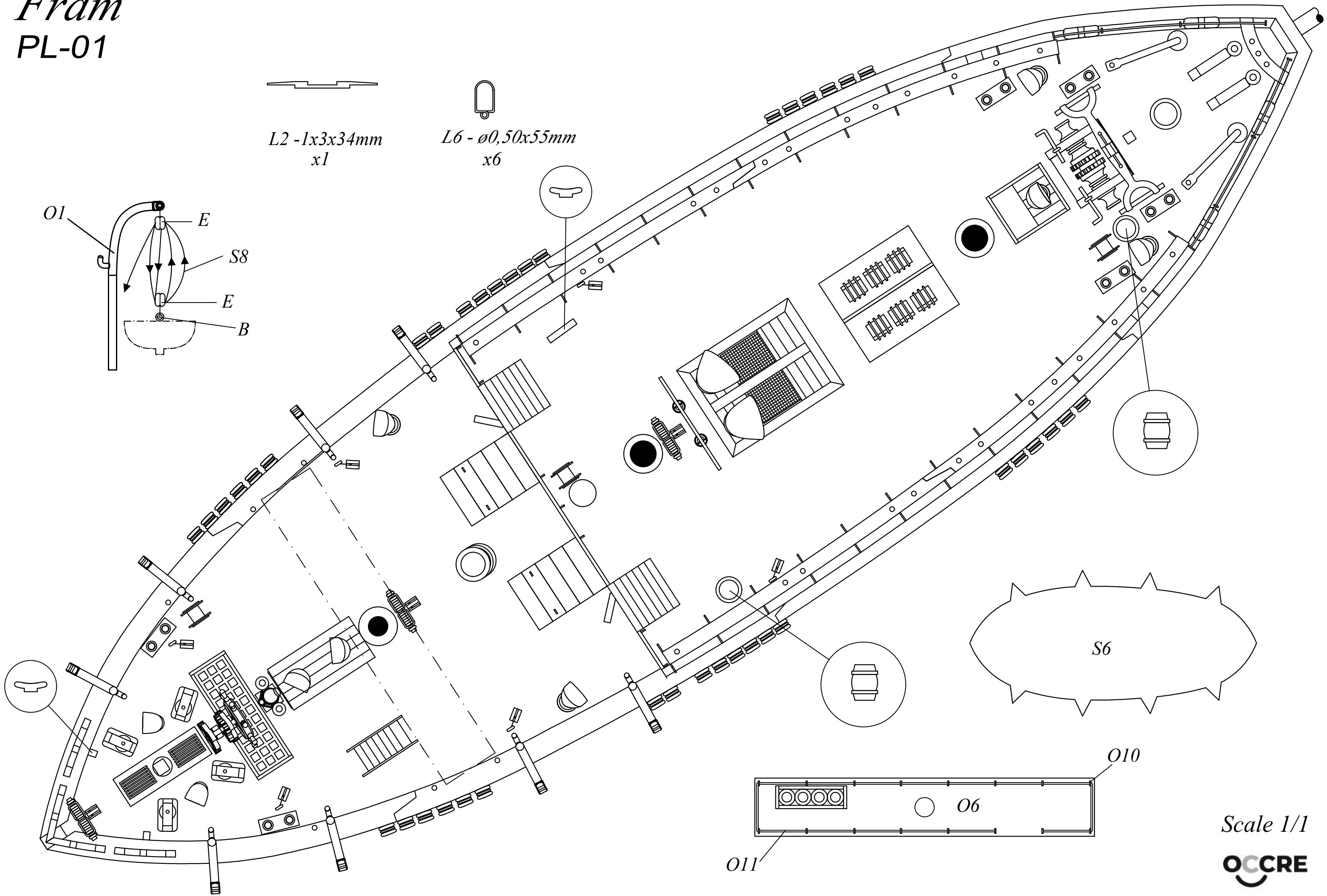

Scale 1/1

Fram

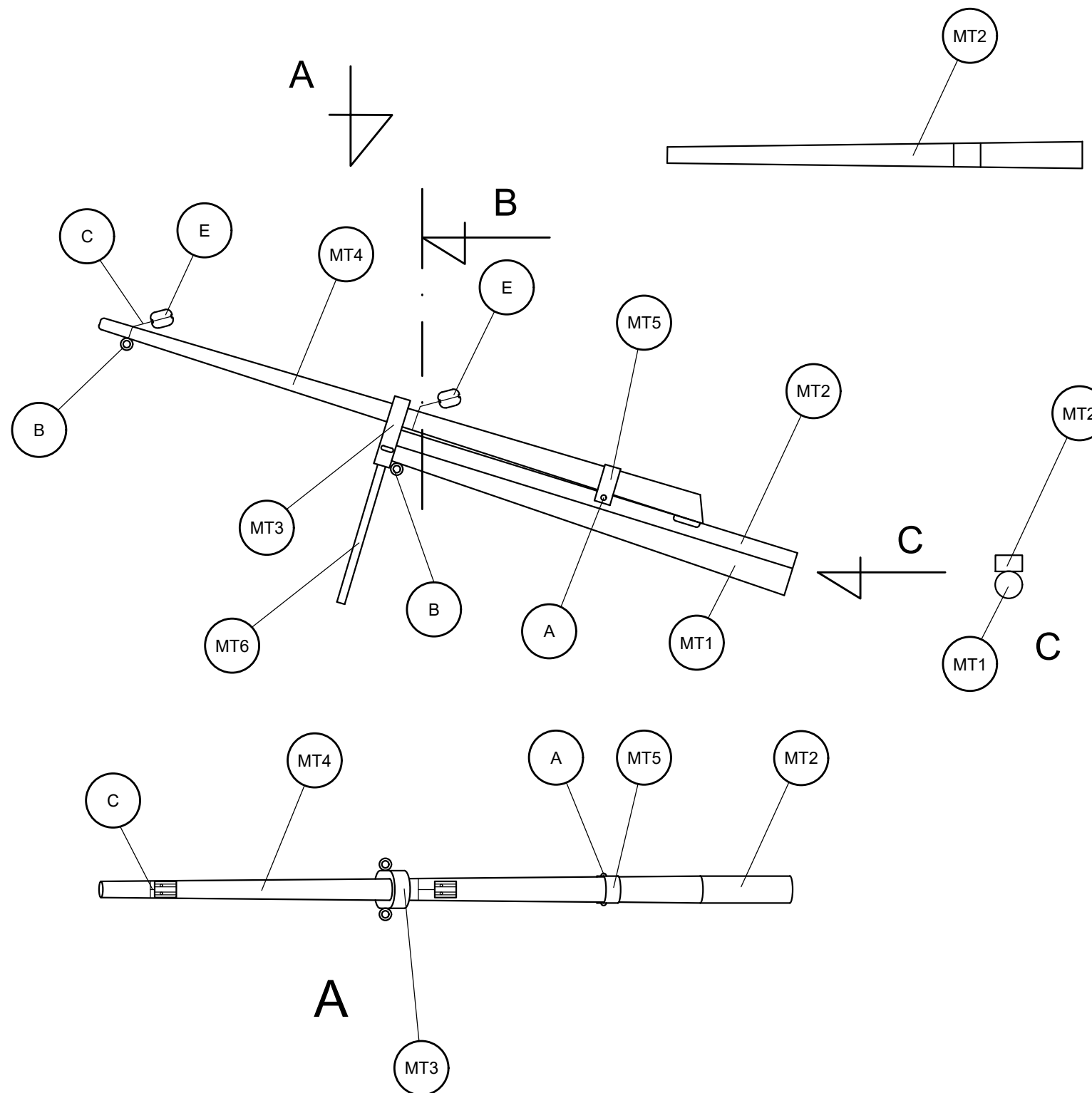
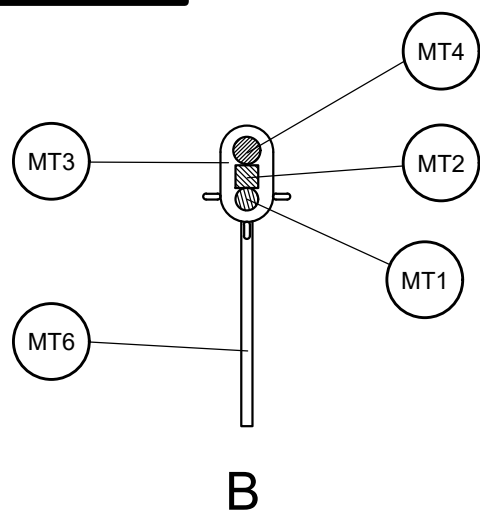
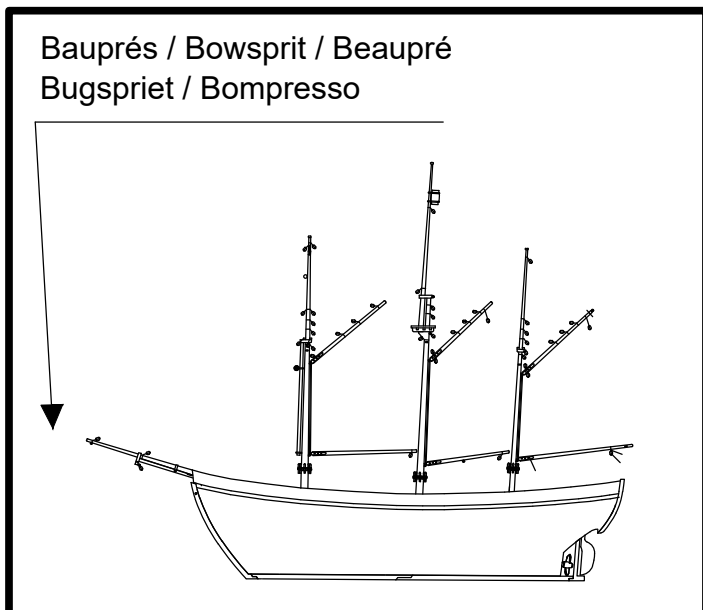

C

MT1	∅5x80	Tilo / Lime wood / Tilleul / Linde / Tiglio
MT2	3x5x77	Tilo / Lime wood / Tilleul / Linde / Tiglio
MT3	Precortado / Precut / Prédécoupé / Vorgeschnitten/ Pretagliato	Tablero / Plywood / Planche / Sperrholz / Tavola
MT4	∅5x118	Tilo / Lime wood / Tilleul / Linde / Tiglio
MT5	3x25	Latón / Brass / Latón / Messing / Ottone
MT6	∅1,5x28	Latón / Brass / Latón / Messing / Ottone
A	10	Metal / Metal / Metal / Metall / Metallo
B	15	Latón / Brass / Laiton / Messing / Ottone
C	∅0,15x100	Hilo crudo / Raw thread / Fil brut / Rohes Baumwollfaden / Filo crudo
D	4	Madera / Wood / Bois / Holz / Legno
E	4	Madera / Wood / Bois / Holz / Legno

Scale 1/1

A		B		D		E		F-G		H		J		K	
<i>Punta</i>		<i>Cáncamo</i>		<i>Moton</i>		<i>Cuadernal</i>		<i>Vigota</i>		<i>Anilla</i>		<i>Cabilla</i>		<i>Vertello</i>	
<i>Pins</i>		<i>Eyebolts</i>		<i>Blocks</i>		<i>Double blocks</i>		<i>Dead eyes</i>		<i>Rings</i>		<i>Belaying Pins</i>		<i>Trucks</i>	
<i>Pointes</i>		<i>Piton à oeil</i>		<i>Poulie</i>		<i>Poulie double</i>		<i>Cap de mouton</i>		<i>Oeil</i>		<i>Cheville</i>		<i>Bertocci</i>	
<i>Stifte</i>		<i>Tragöse</i>		<i>Blockrolle</i>		<i>Block</i>		<i>Jungferblock</i>		<i>Öse</i>		<i>Rundeisen</i>		<i>Racktaublöcke</i>	
<i>Punte</i>		<i>Cavilie di ferro ad anello</i>		<i>Bozzello</i>		<i>Costale</i>		<i>Bigotta</i>		<i>Anello</i>		<i>Caviglia</i>		<i>Pomme de racage</i>	

Fram

Palo trinquete / Fore mast / Mât de misaine
 Albero trinchetto / Fockmast

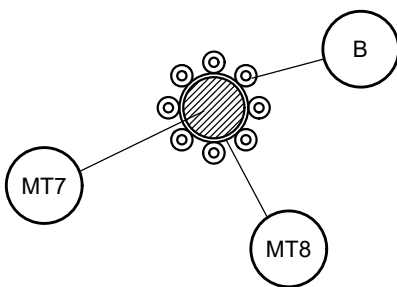
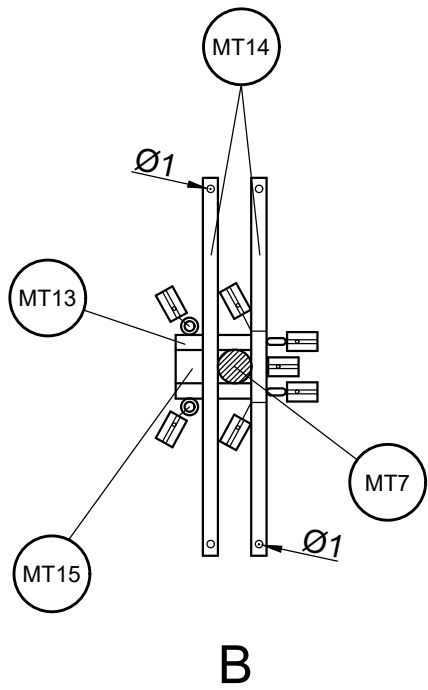
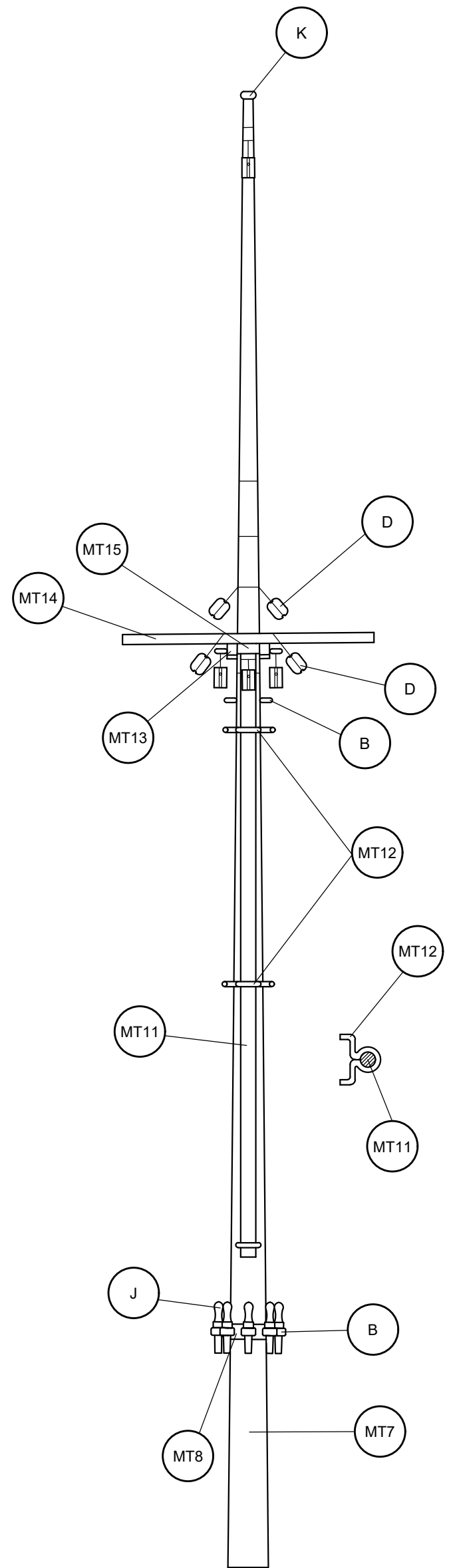
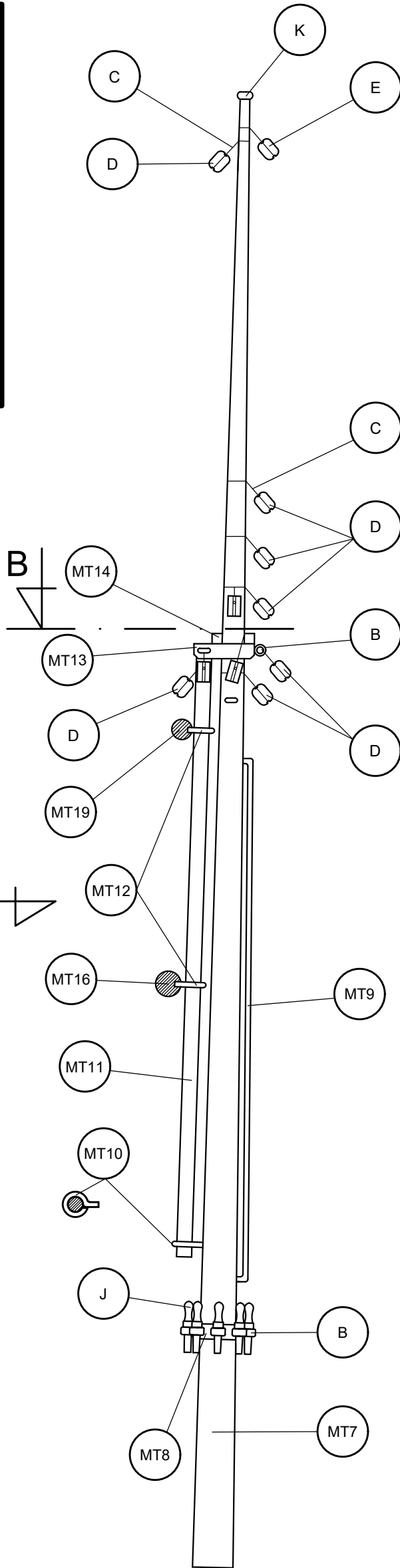
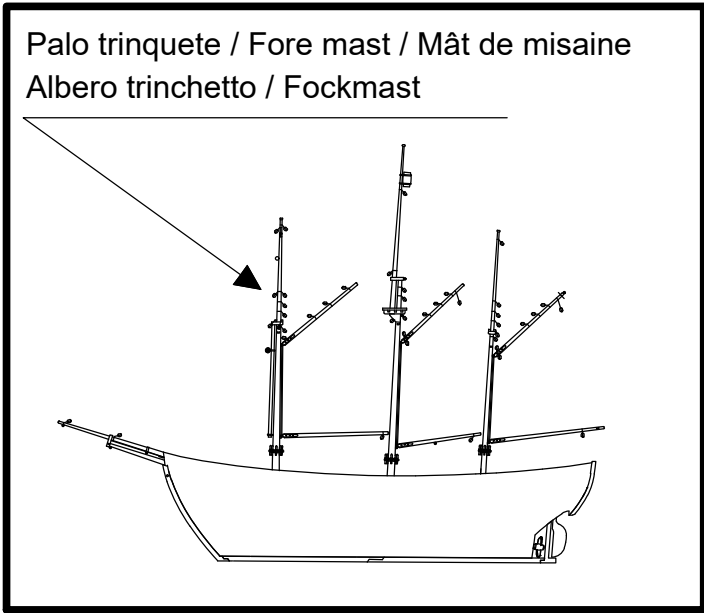

A

Scale 1/1

MT7	ø8x292	Tilo / Lime wood / Tilleul / Linde / Tiglio	MT15	2x5x5	Tilo / Lime wood / Tilleul / Linde / Tiglio
MT8	3x30	Latón / Brass / Laiton / Messing / Ottone	B	15	Latón / Brass / Laiton / Messing / Ottone
MT9	ø1x115	Latón / Brass / Laiton / Messing / Ottone	C	ø0,15x100	Hilo crudo / Raw thread / Fil brut / Rohes Baumwollfaden / Filo crudo
MT10	ø1x20	Latón / Brass / Laiton / Messing / Ottone	D	4	Madera / Wood / Bois / Holz / Legno
MT11	ø3x120	Tilo / Lime wood / Tilleul / Linde / Tiglio	E	4	Madera / Wood / Bois / Holz / Legno
MT12	ø1x40	Latón / Brass / Laiton / Messing / Ottone	J	10	Madera / Wood / Bois / Holz / Legno
MT13	2x3x12	Tilo / Lime wood / Tilleul / Linde / Tiglio	K	ø3	Cristal / Glass / Verre / Glas / Cristallo
MT14	2x2x50	Tilo / Lime wood / Tilleul / Linde / Tiglio			

Fram

Palo trinquete / Fore mast / Mât de misaine
 Albero trinchetto / Fockmast

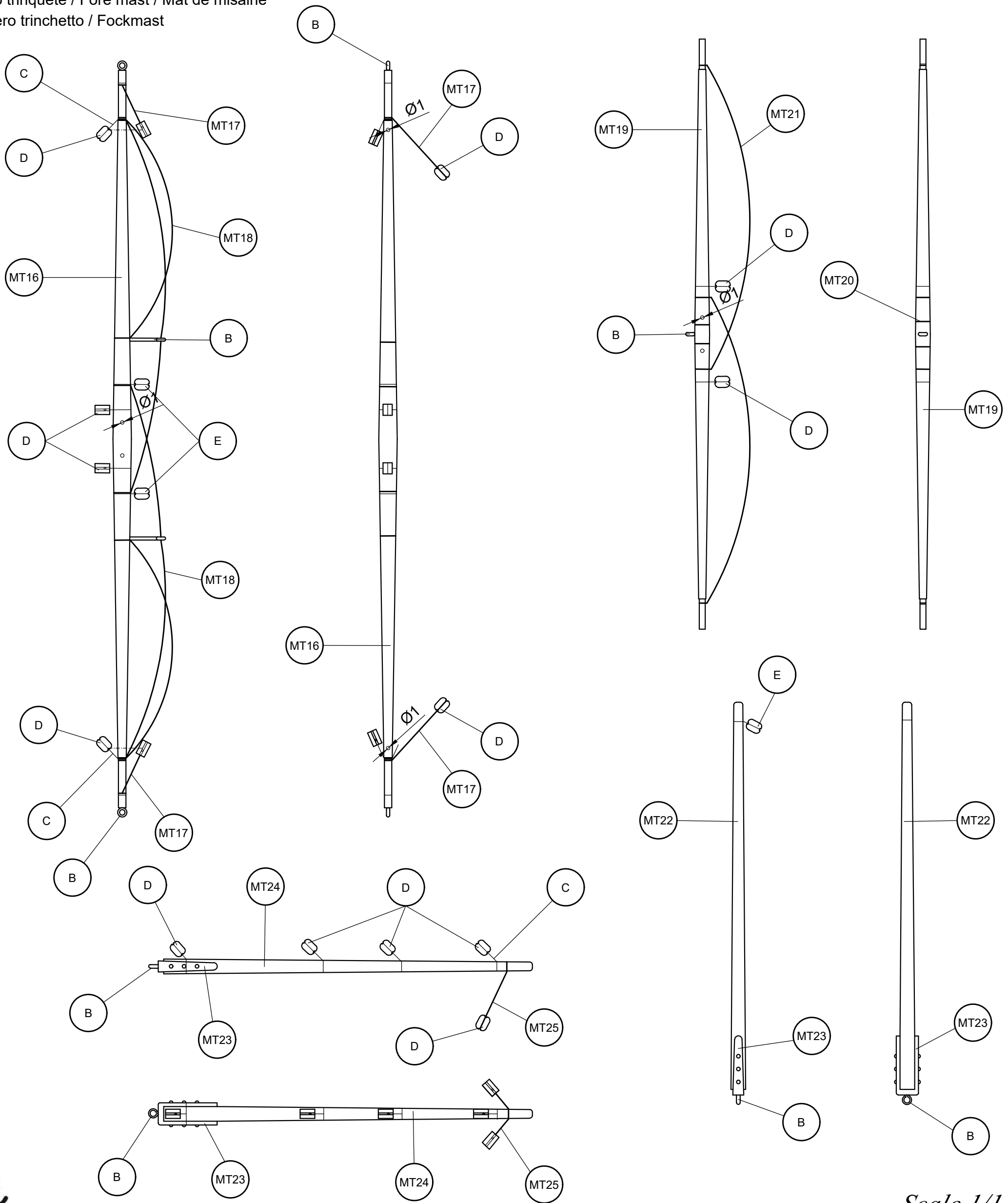

Scale 1/1

MT16	ø5x200	Tilo / Lime wood / Tilleul / Linde / Tiglio	MT23	Preformado / Preformed / Préformé / Vorgeformt / Preformato	Metal / Metal / Metal / Metall / Metallo
MT17	ø0,50x125	Hilo marrón / Brown thread / Fil brun / braunes Baumwollfaden / Filo marrone	MT24	ø4x100	Tilo / Lime wood / Tilleul / Linde / Tiglio
MT18	ø0,50x200	Hilo marrón / Brown thread / Fil brun / braunes Baumwollfaden / Filo marrone	MT25	ø0,50x100	Hilo marrón / Brown thread / Fil brun / braunes Baumwollfaden / Filo marrone
MT19	ø4x160	Tilo / Lime wood / Tilleul / Linde / Tiglio	B	15	Latón / Brass / Laiton / Messing / Ottone
MT20	ø0,50x150	Hilo marrón / Brown thread / Fil brun / braunes Baumwollfaden / Filo marrone	C	ø0,15x100	Hilo crudo / Raw thread / Fil brut / Rohes Baumwollfaden / Filo crudo
MT21	ø0,50x175	Hilo marrón / Brown thread / Fil brun / braunes Baumwollfaden / Filo marrone	D	4	Madera / Wood / Bois / Holz / Legno
MT22	ø4x105	Tilo / Lime wood / Tilleul / Linde / Tiglio	E	4	Madera / Wood / Bois / Holz / Legno

Fram

Palo mayor / Main mast / Grand mât
Hauptmast / Albero maestro

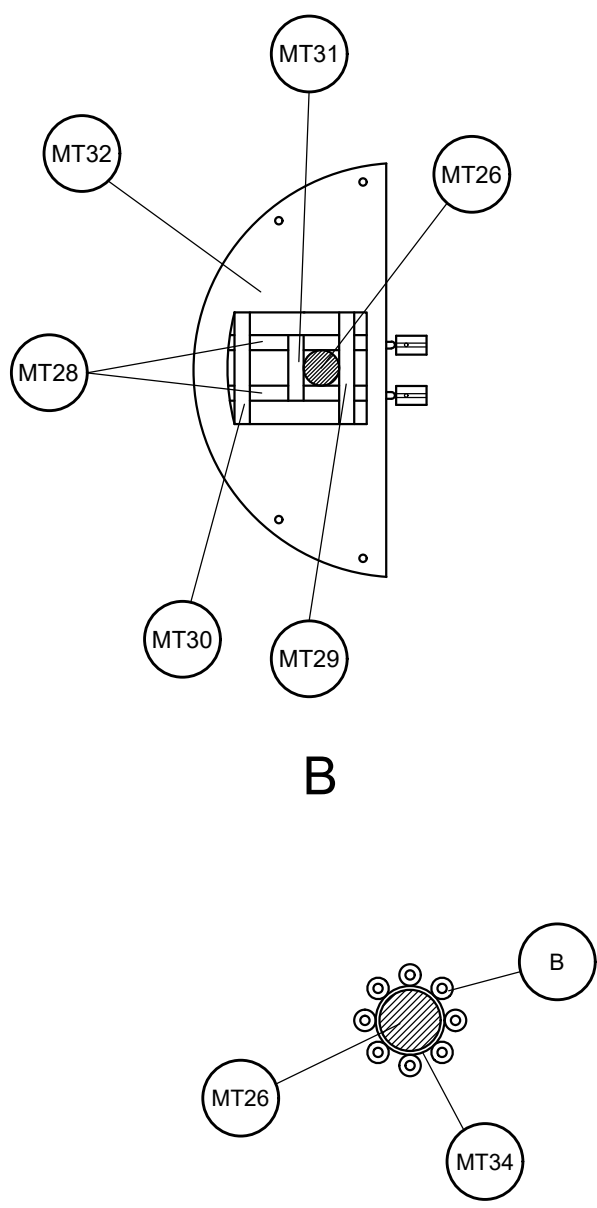
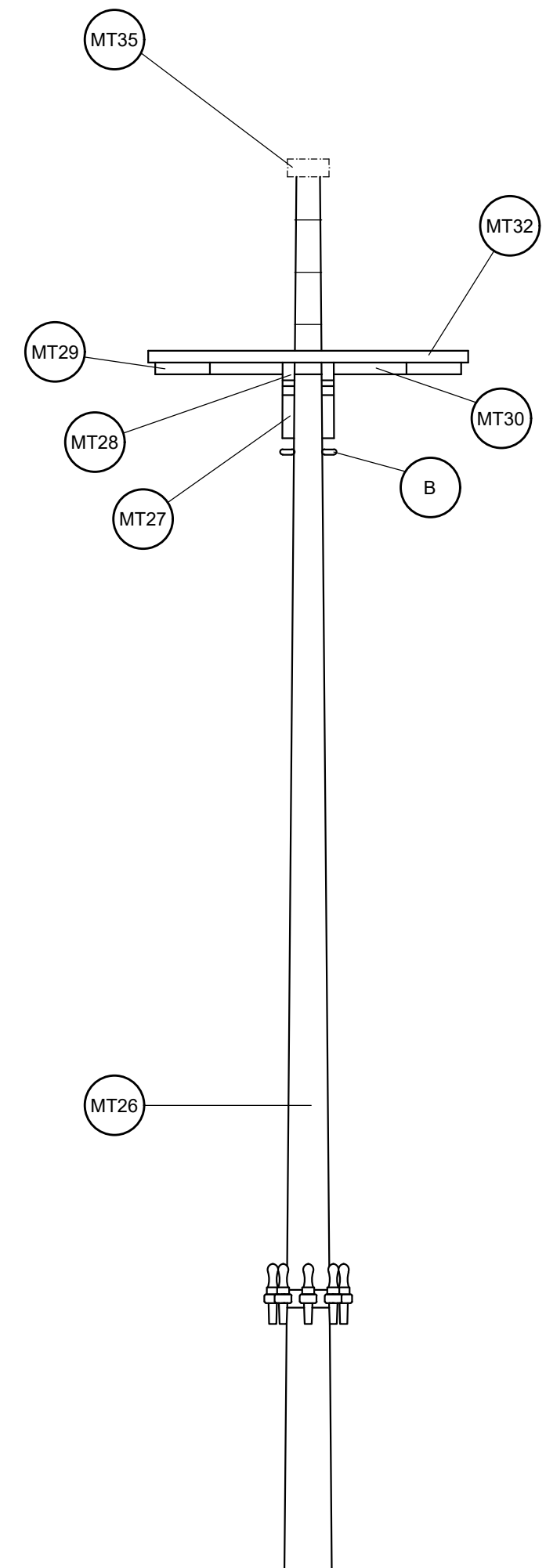
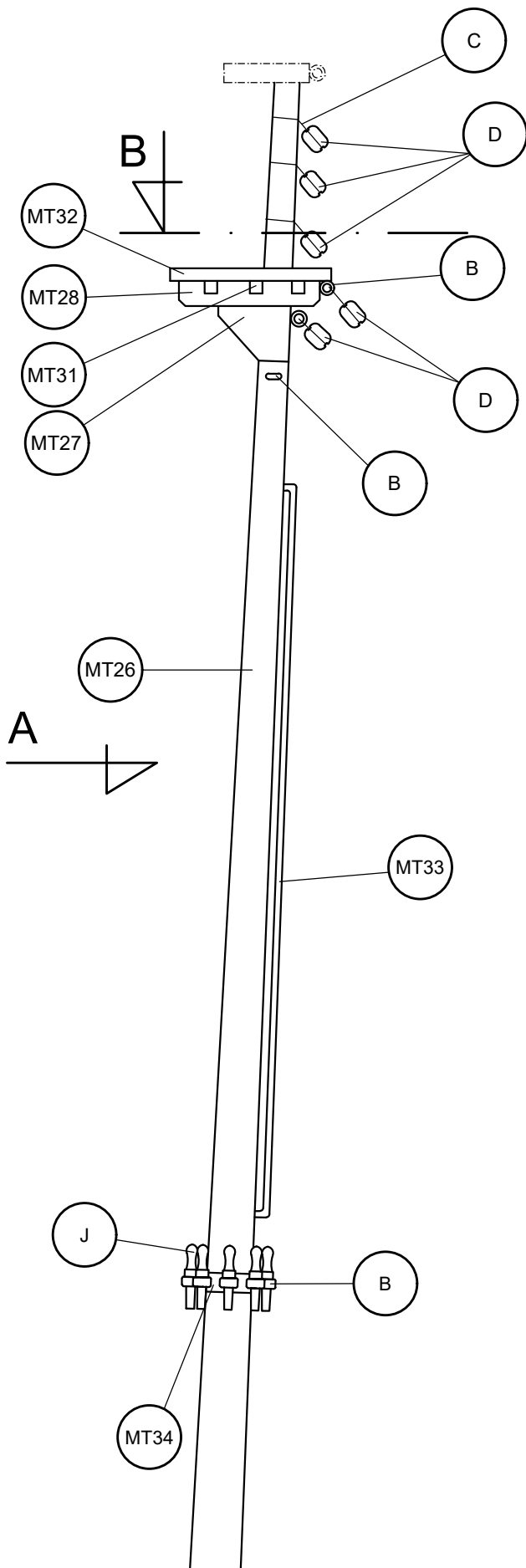
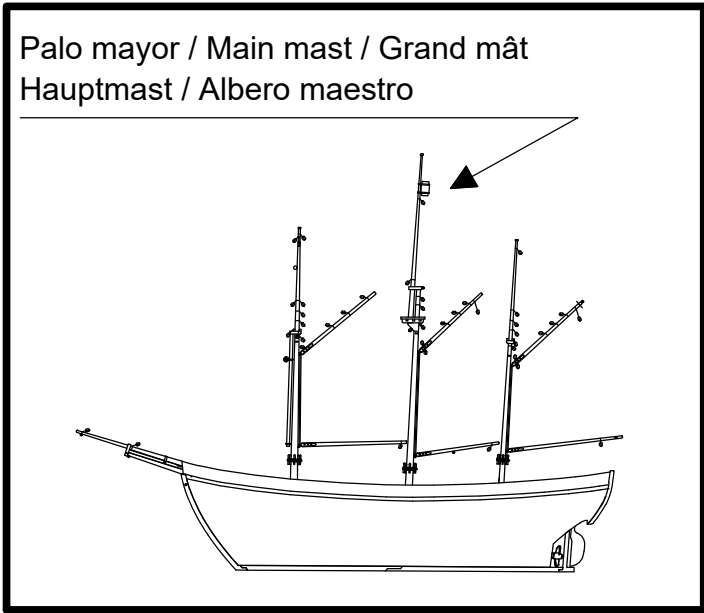

Scale 1/1

MT26	ø8x239	Tilo / Lime wood / Tilleul / Linde / Tiglio	MT33	ø1x120	Latón / Brass / Laiton / Messing / Ottone
MT27	Precortado / Precut / Prédécoupé / Vorgeschnitten / Pretagliato	Tablero / Plywood / Planche / Sperrholz / Tavola	MT34	3x30	Latón / Brass / Laiton / Messing / Ottone
MT28	Precortado / Precut / Prédécoupé / Vorgeschnitten / Pretagliato	Tablero / Plywood / Planche / Sperrholz / Tavola	B	15	Latón / Brass / Laiton / Messing / Ottone
MT29	2x2x52	Tilo / Lime wood / Tilleul / Linde / Tiglio	C	ø0,15x100	Hilo crudo / Raw thread / Fil brut / Rohes Baumwollfaden / Filo crudo
MT30	2x2x33	Tilo / Lime wood / Tilleul / Linde / Tiglio	D	4	Madera / Wood / Bois / Holz / Legno
MT31	2x2x9	Tilo / Lime wood / Tilleul / Linde / Tiglio	E	4	Madera / Wood / Bois / Holz / Legno
MT32	Precortado / Precut / Prédécoupé / Vorgeschnitten / Pretagliato	Tablero / Plywood / Planche / Sperrholz / Tavola	J	10	Madera / Wood / Bois / Holz / Legno

Fram

Palo mayor / Main mast / Grand mât
Hauptmast / Albero maestro

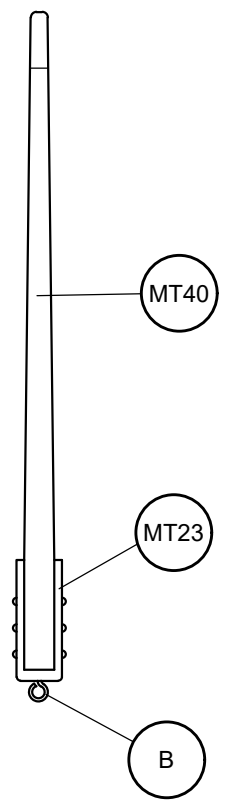
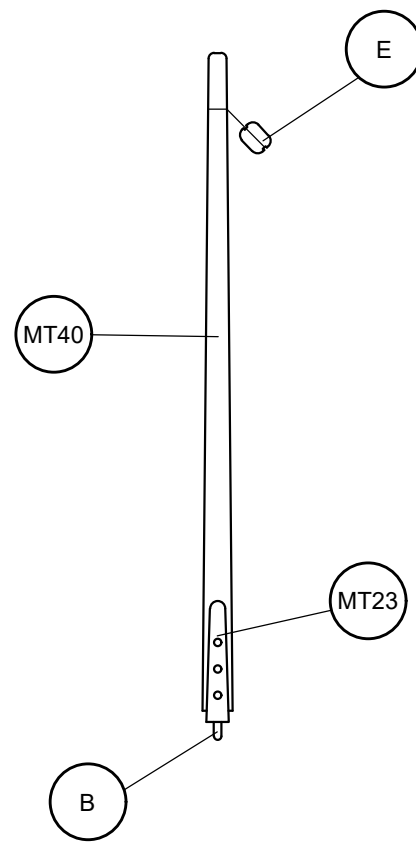
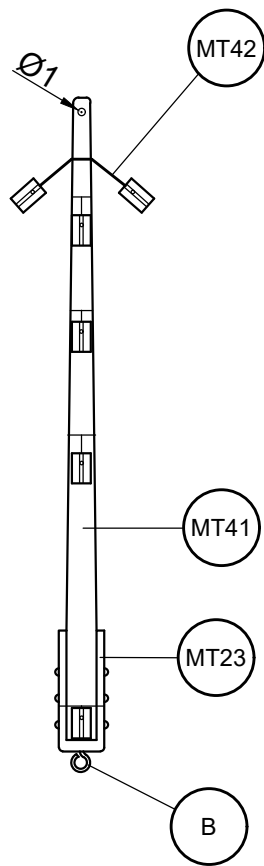
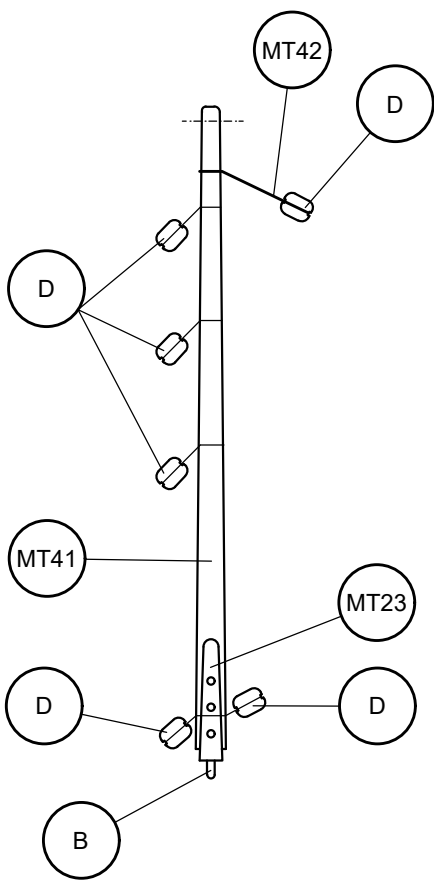
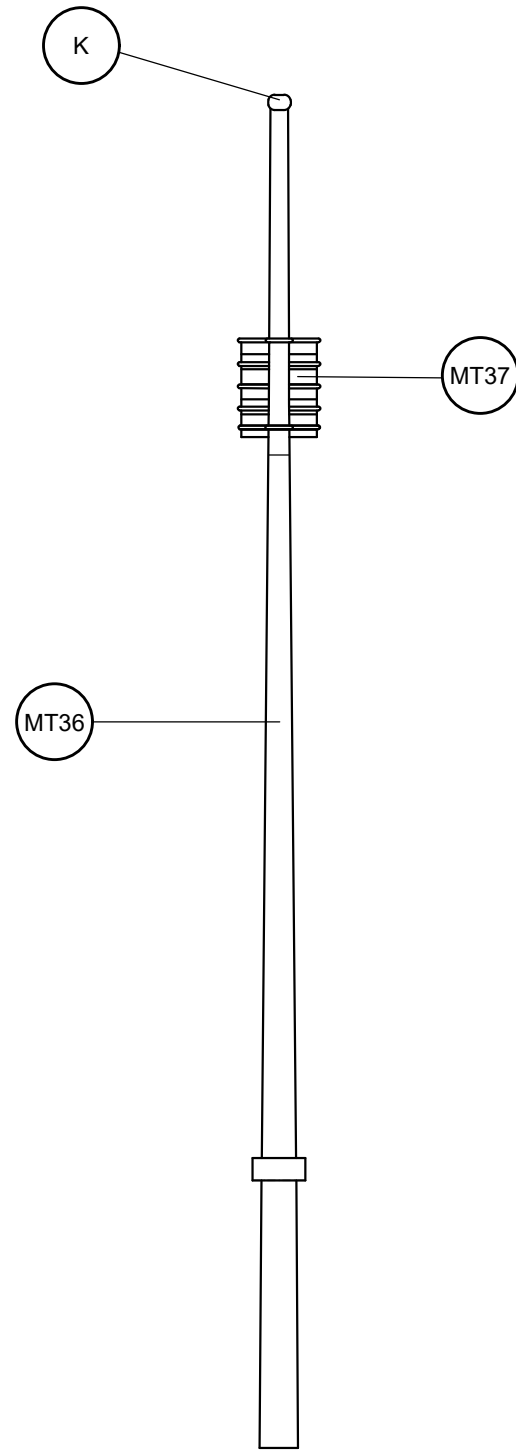
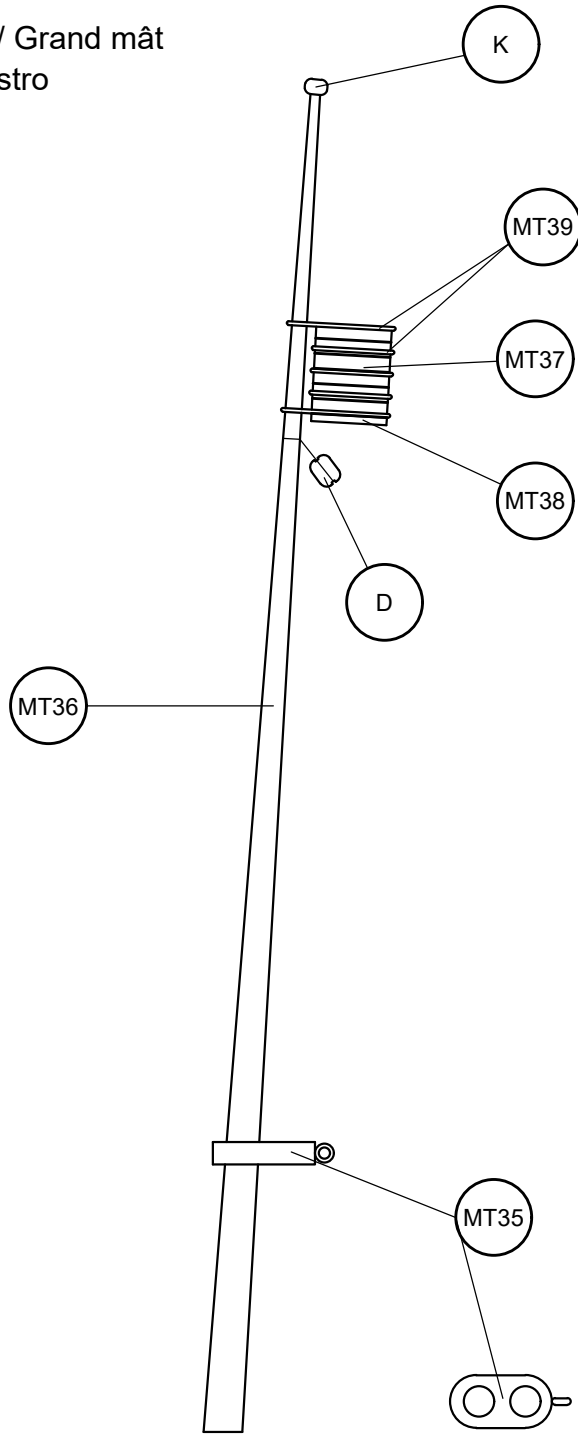

Scale 1/1

MT35	Precortado / Precut / Prédécoupé / Vorgeschnitten/ Pretagliato	Tablero / Plywood / Planche / Sperrholz / Tavola	MT42	ø0,50x100	Hilo marrón / Brown thread / Fil brun /braunes Baumwollfaden / Filo marrone
MT36	ø5x177	Tilo / Lime wood / Tilleul / Linde / Tiglio	B	15	Latón / Brass / Laiton / Messing / Ottone
MT37	Preformado / Preformed/ Préformé / Vorgeformt / Preformato	Madera / Wood / Bois / Holz / Legno	C	ø0,15x100	Hilo crudo / Raw thread / Fil brut / Rohes Baumwollfaden / Filo crudo
MT38	1x3x10	Tilo / Lime wood / Tilleul / Linde / Tiglio	D	4	Madera / Wood / Bois / Holz / Legno
MT39	ø0,50x30	Latón / Brass / Laiton / Messing / Ottone	E	4	Madera / Wood / Bois / Holz / Legno
MT40	ø4x87	Tilo / Lime wood / Tilleul / Linde / Tiglio	K	ø3	Cristal / Glass / Verre / Glas / Cristallo
MT41	ø4x85	Tilo / Lime wood / Tilleul / Linde / Tiglio			

Fram

Palo mesana / Mizze mast / Mât d'artimon
Besanmast / Albero mezzana

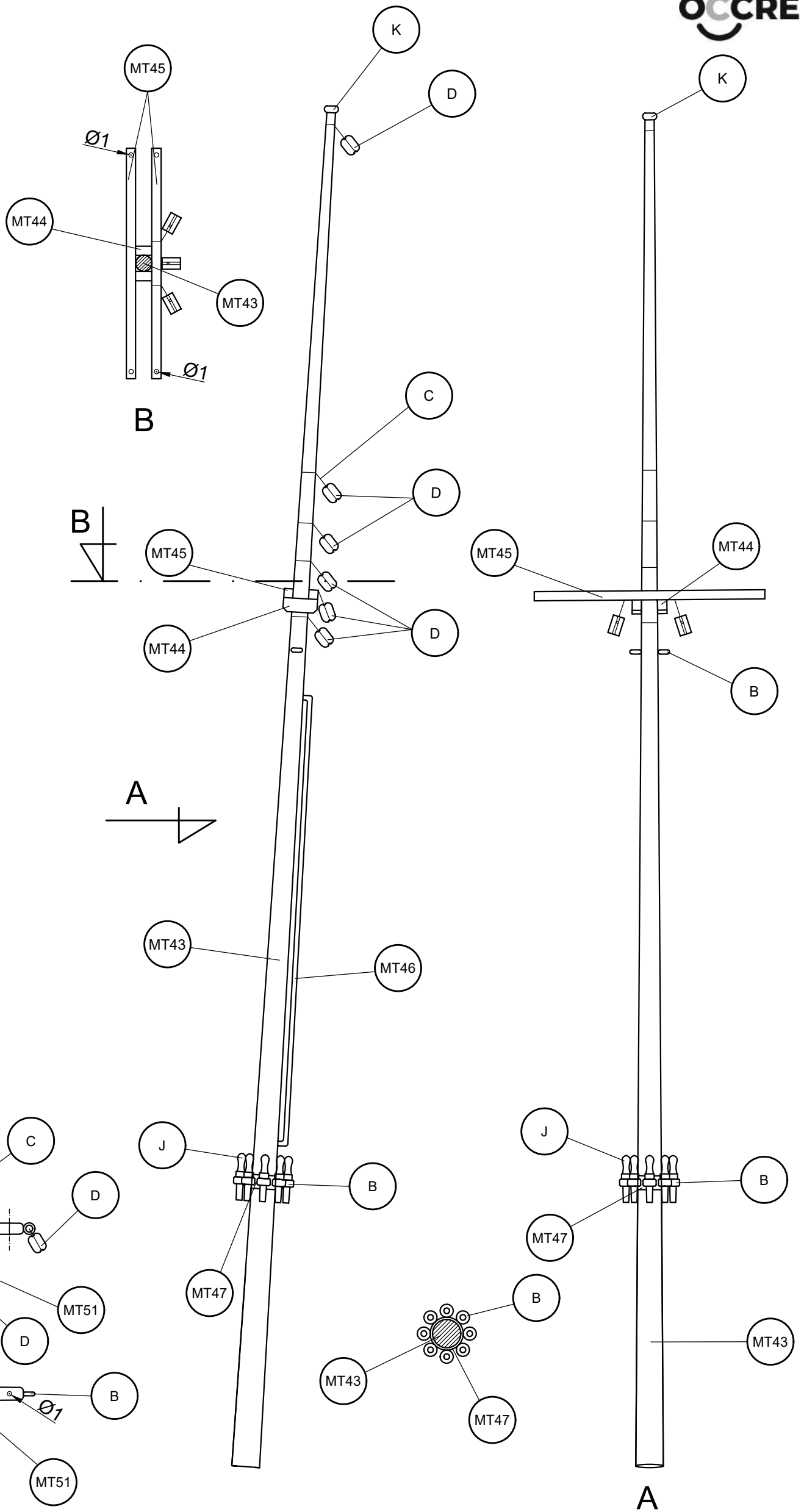
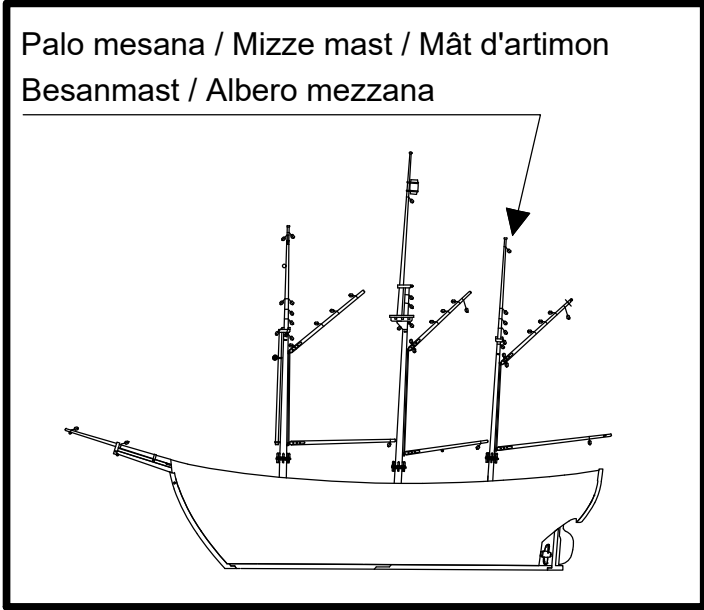

Scale 1/1

MT43	ø6x294	Tilo / Lime wood / Tilleul / Linde / Tiglio	MT51	ø0,50x100	Hilo marrón / Brown thread / Fil brun/braunes Baumwollfaden / Filo marrone
MT44	2x3x8	Tilo / Lime wood / Tilleul / Linde / Tiglio	B	15	Latón / Brass / Laiton / Messing / Ottone
MT45	2x2x50	Tilo / Lime wood / Tilleul / Linde / Tiglio	C	ø0,15x100	Hilo crudo / Raw thread / Fil brut / Rohes Baumwollfaden / Filo crudo
MT46	ø1x110	Latón / Brass / Laiton / Messing / Ottone	D	4	Madera / Wood / Bois / Holz / Legno
MT47	3x30	Latón / Brass / Laiton / Messing / Ottone	E	4	Madera / Wood / Bois / Holz / Legno
MT48	ø4x120	Tilo / Lime wood / Tilleul / Linde / Tiglio	J	10	Madera / Wood / Bois / Holz / Legno
MT49	Preformado / Preformed / Préformé / Vorgeformt / Preformato	Metal / Metal / Metal / Metall / Metallo	K	ø3	Cristal / Glass / Verre / Glas / Cristallo
MT50	ø4x98	Tilo / Lime wood / Tilleul / Linde / Tiglio			

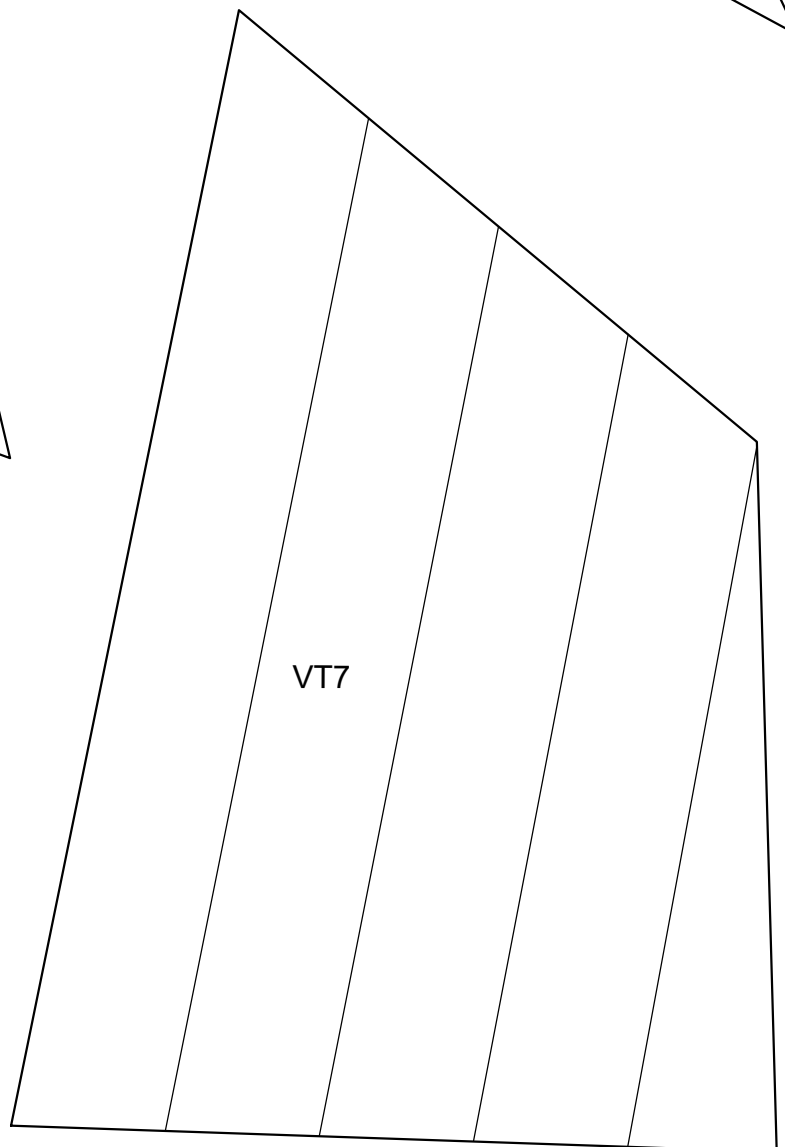
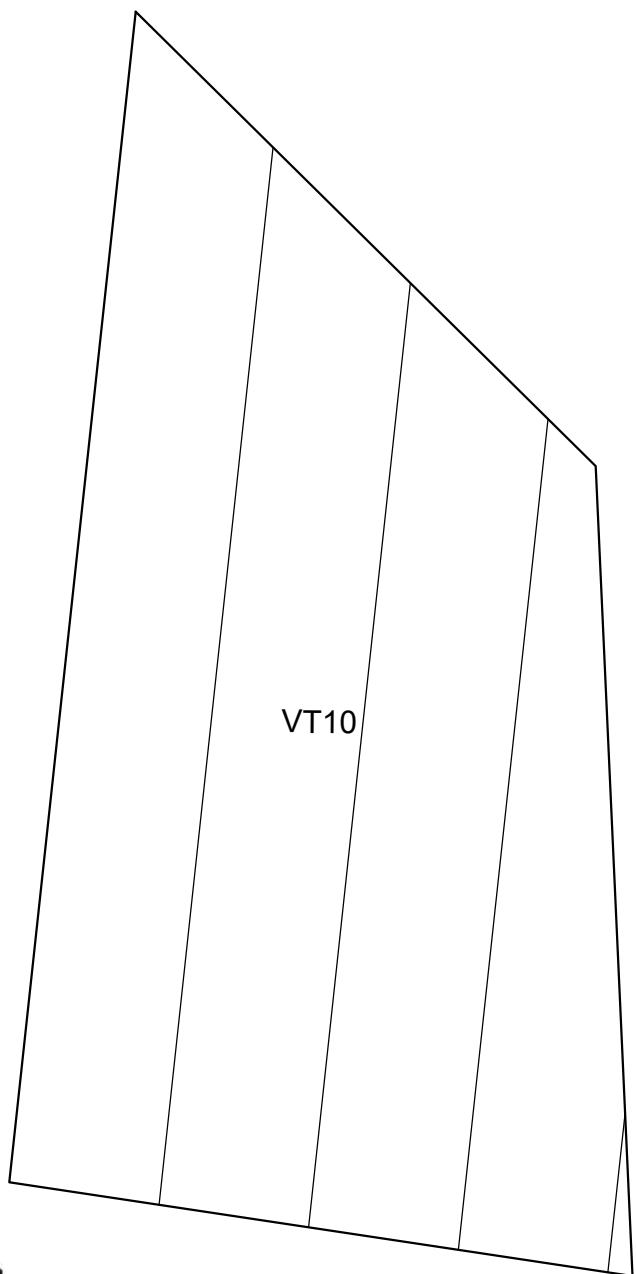
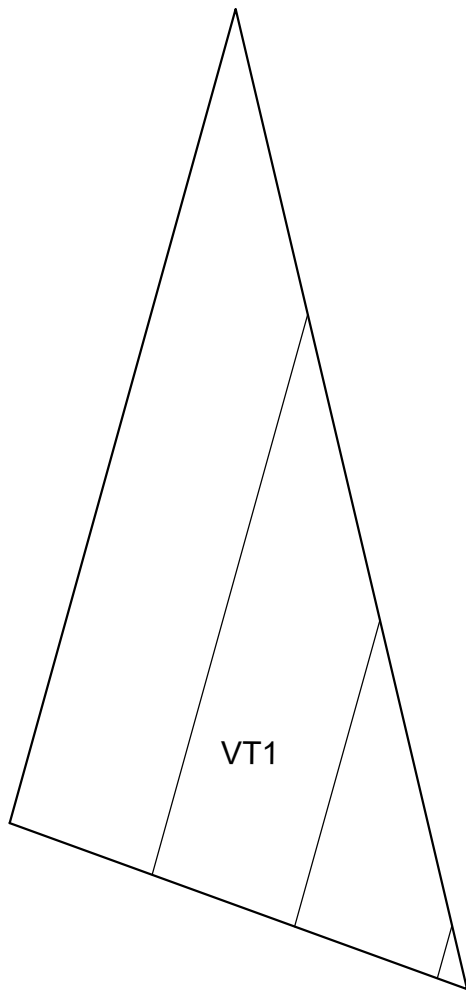
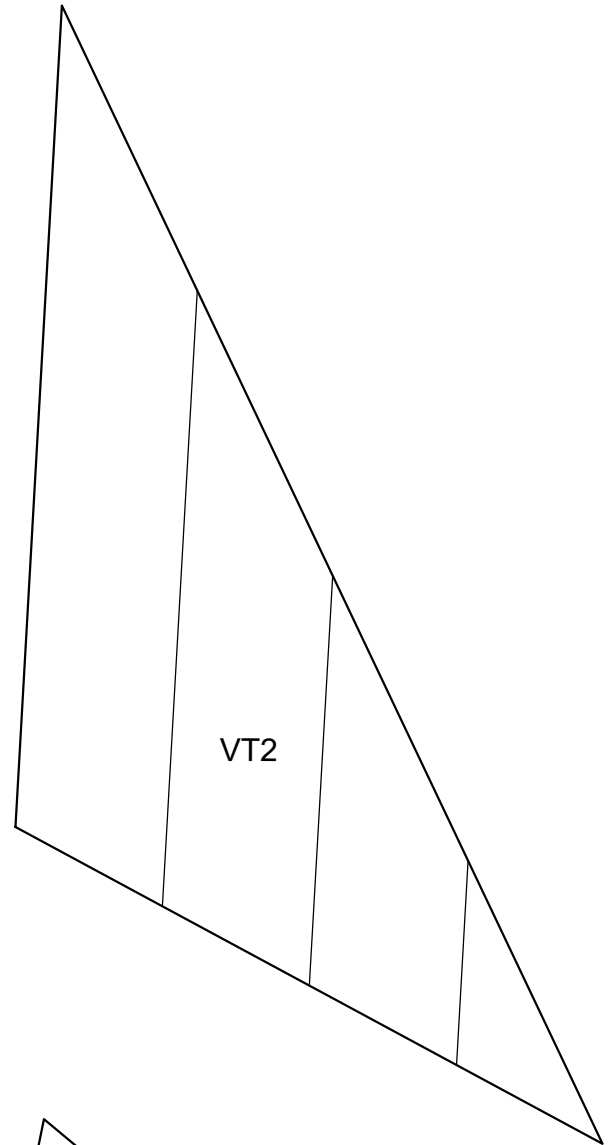
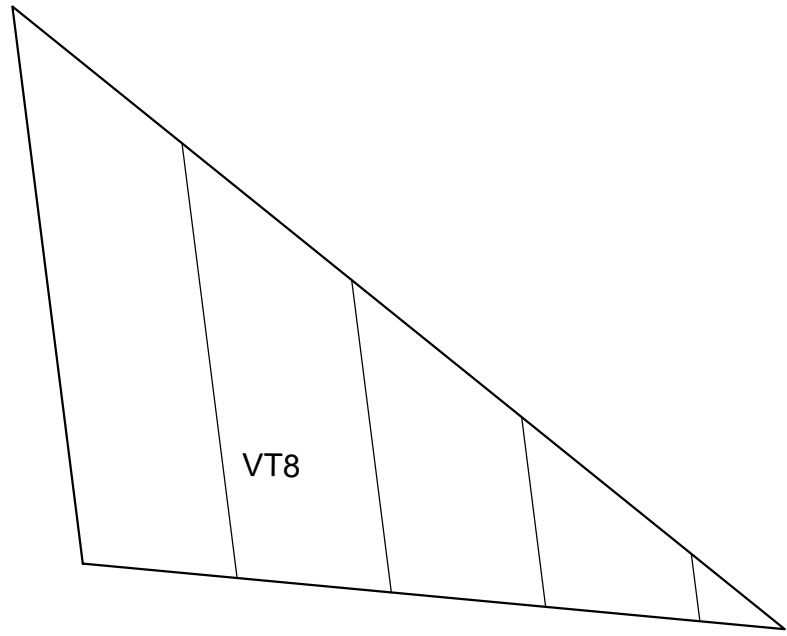
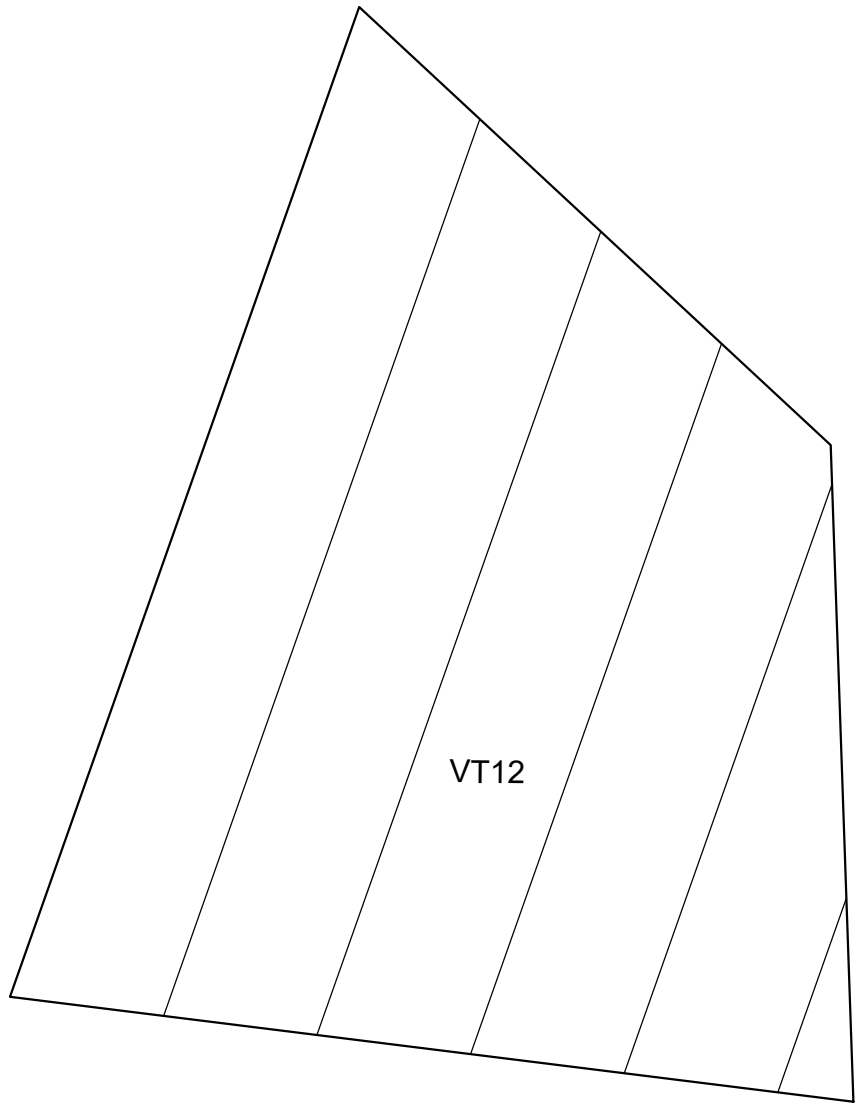

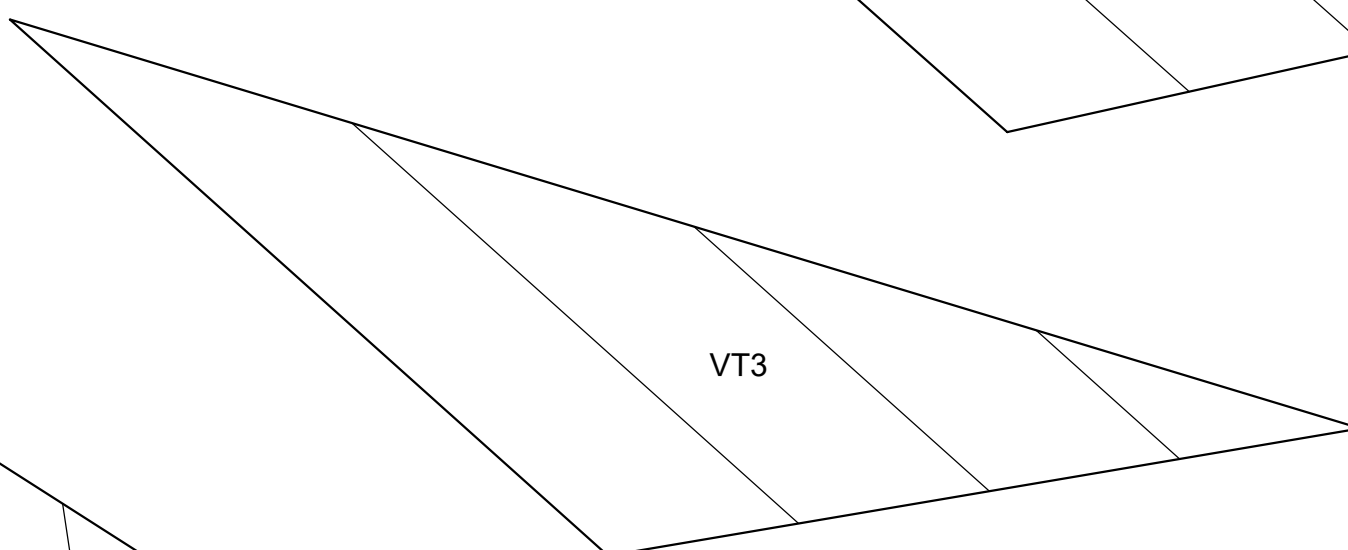
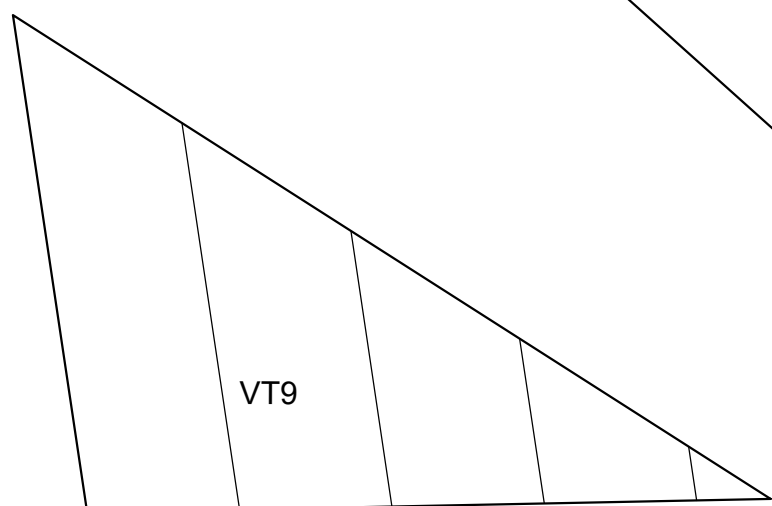
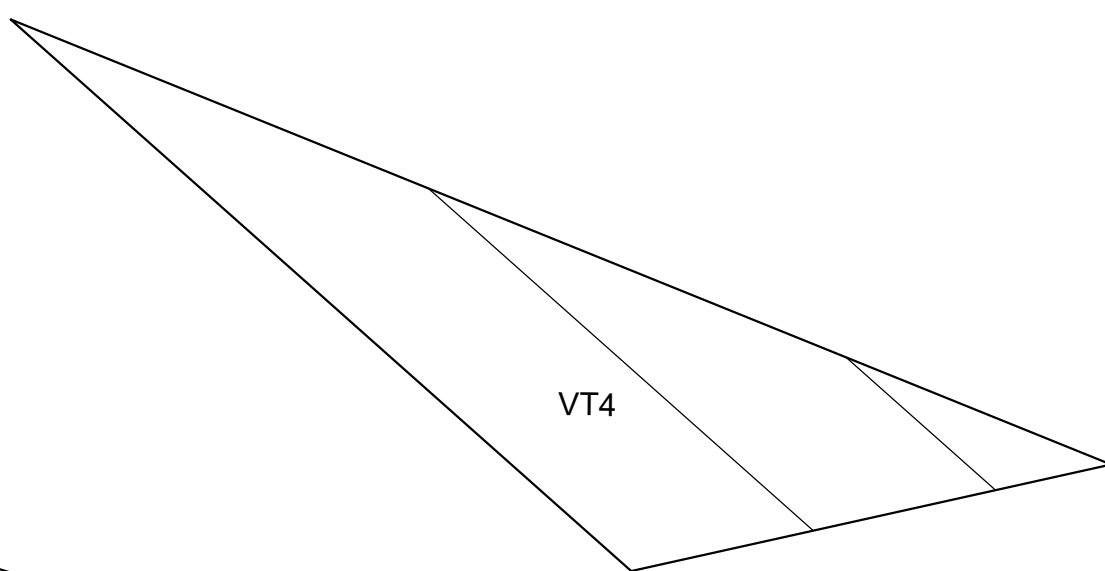
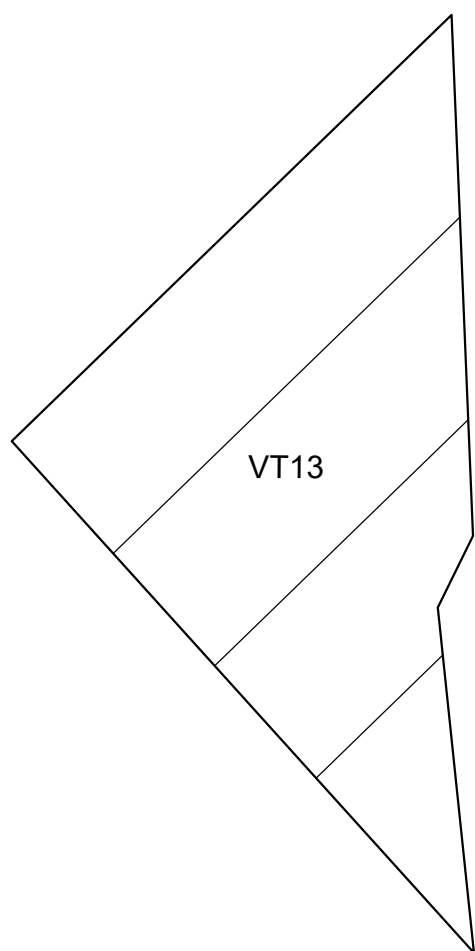
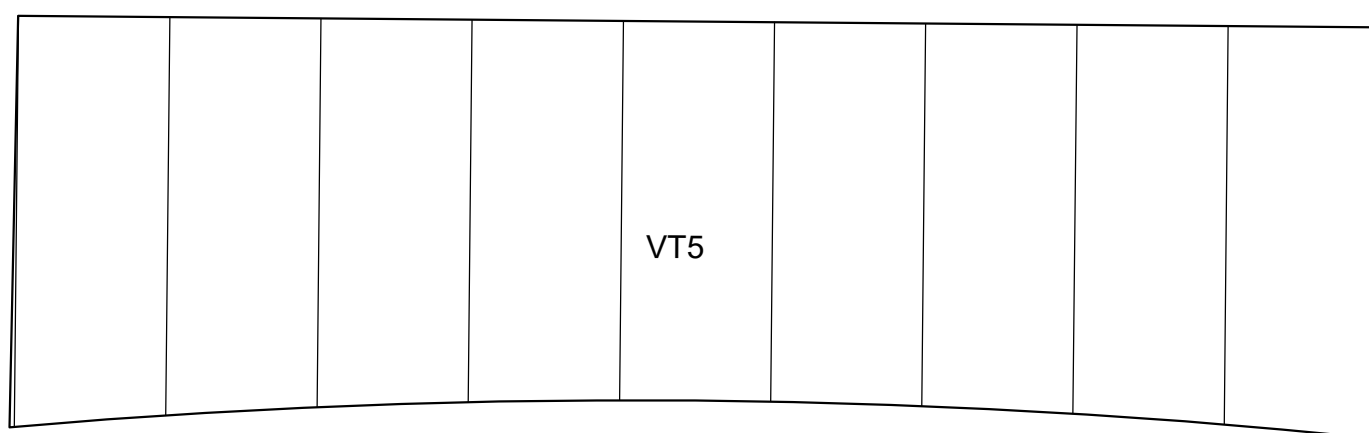
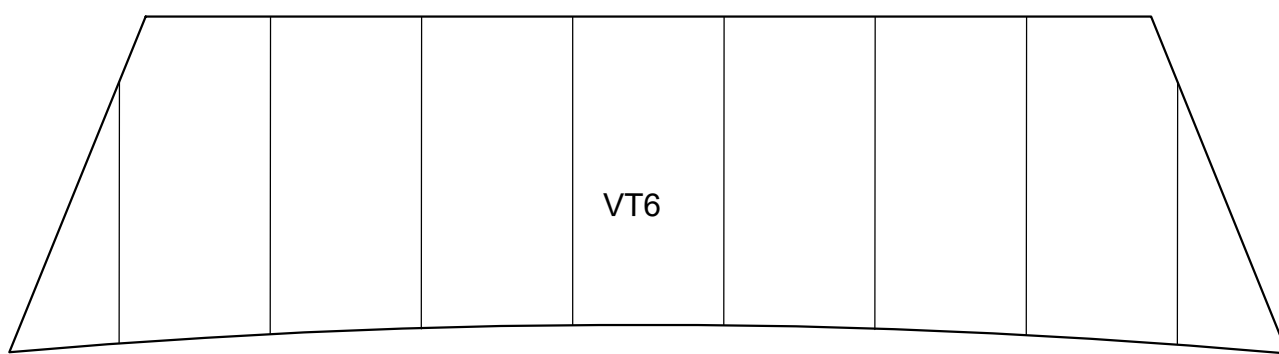
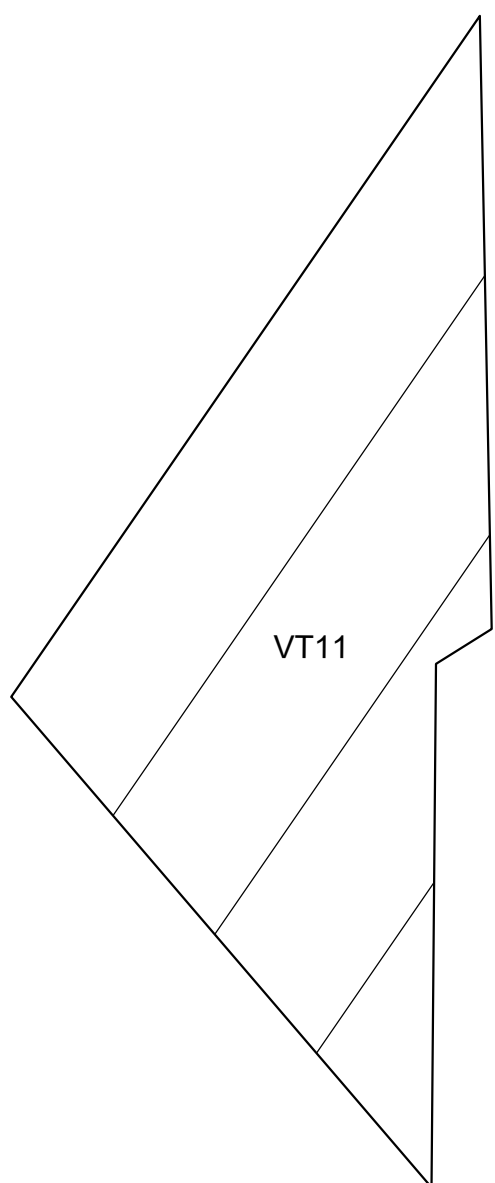

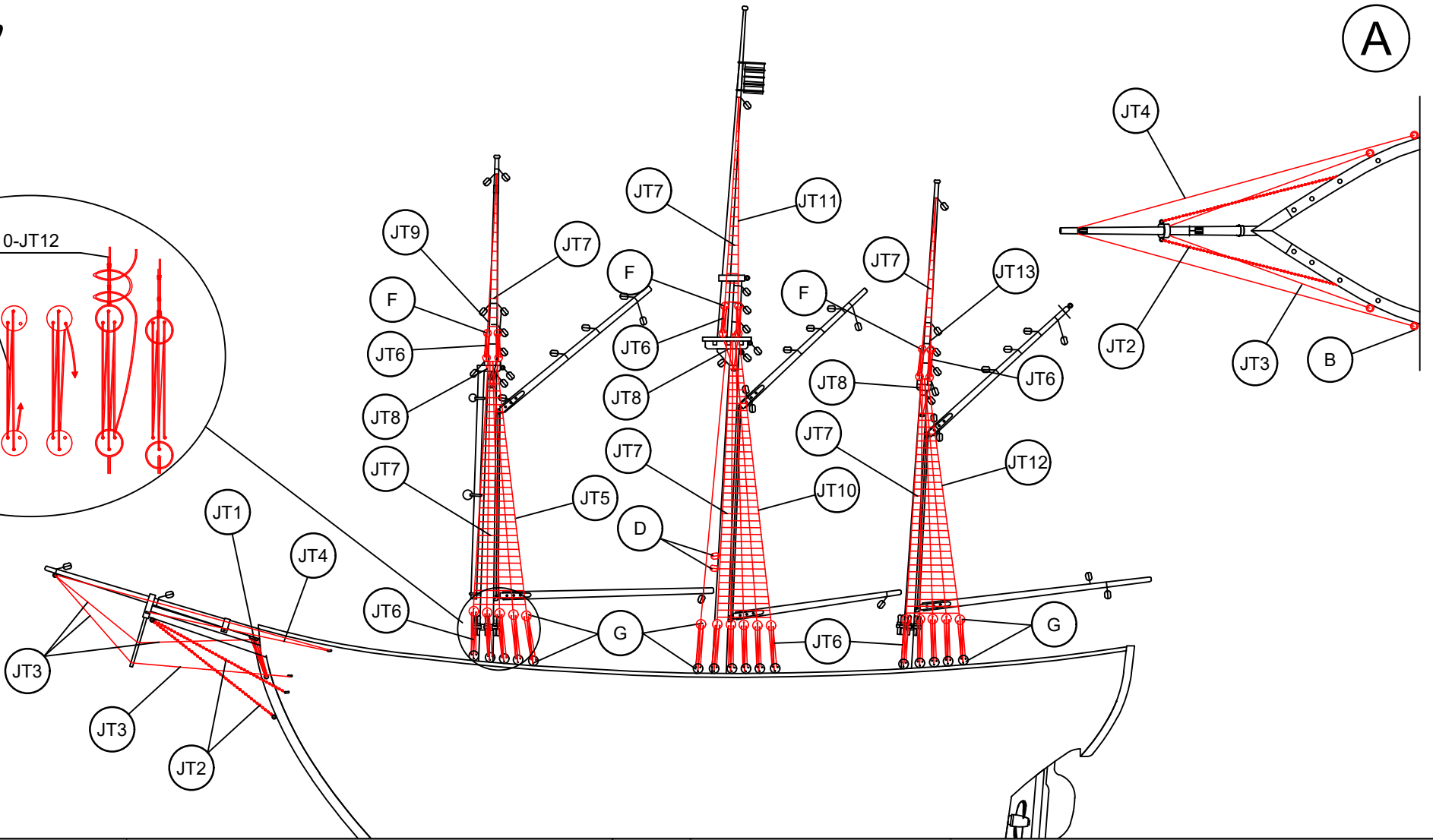
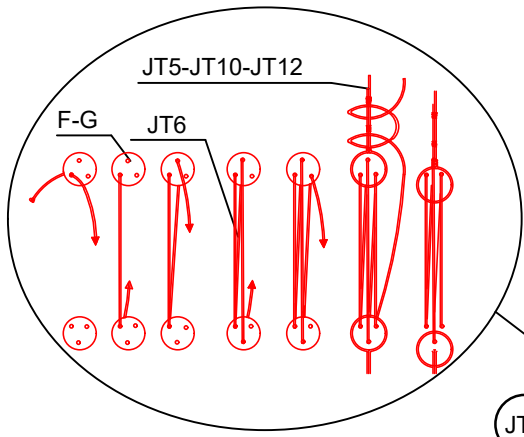

JT1	∅0,50x300	Hilo marrón / Brown thread / Fil brun / braunes Baumwollfaden / Filo marrone	JT9	∅0,50x350	Hilo marrón / Brown thread / Fil brun / braunes Baumwollfaden / Filo marrone
JT2	1x125	Latón / Brass / Laiton / Messing / Ottone	JT10	∅0,50x500	Hilo marrón / Brown thread / Fil brun / braunes Baumwollfaden / Filo marrone
JT3	∅0,50x250	Hilo marrón / Brown thread / Fil brun / braunes Baumwollfaden / Filo marrone	JT11	∅0,50x400	Hilo marrón / Brown thread / Fil brun / braunes Baumwollfaden / Filo marrone
JT4	∅0,50x250	Hilo marrón / Brown thread / Fil brun / braunes Baumwollfaden / Filo marrone	JT12	∅0,50x450	Hilo marrón / Brown thread / Fil brun / braunes Baumwollfaden / Filo marrone
JT5	∅0,50x300	Hilo marrón / Brown thread / Fil brun / braunes Baumwollfaden / Filo marrone	JT13	∅0,50x350	Hilo marrón / Brown thread / Fil brun / braunes Baumwollfaden / Filo marrone
JT6	∅0,15x250	Hilo marrón / Brown thread / Fil brun / braunes Baumwollfaden / Filo marrone	D	4	Madera / Wood / Bois / Holz / Legno
JT7	∅0,15x125	Hilo crudo / Raw thread / Fil brut / Rohes Baumwollfaden / Filo crudo	F	4	Madera / Wood / Bois / Holz / Legno
JT8	∅0,50x150	Hilo marrón / Brown thread / Fil brun / braunes Baumwollfaden / Filo marrone	G	5	Madera / Wood / Bois / Holz / Legno

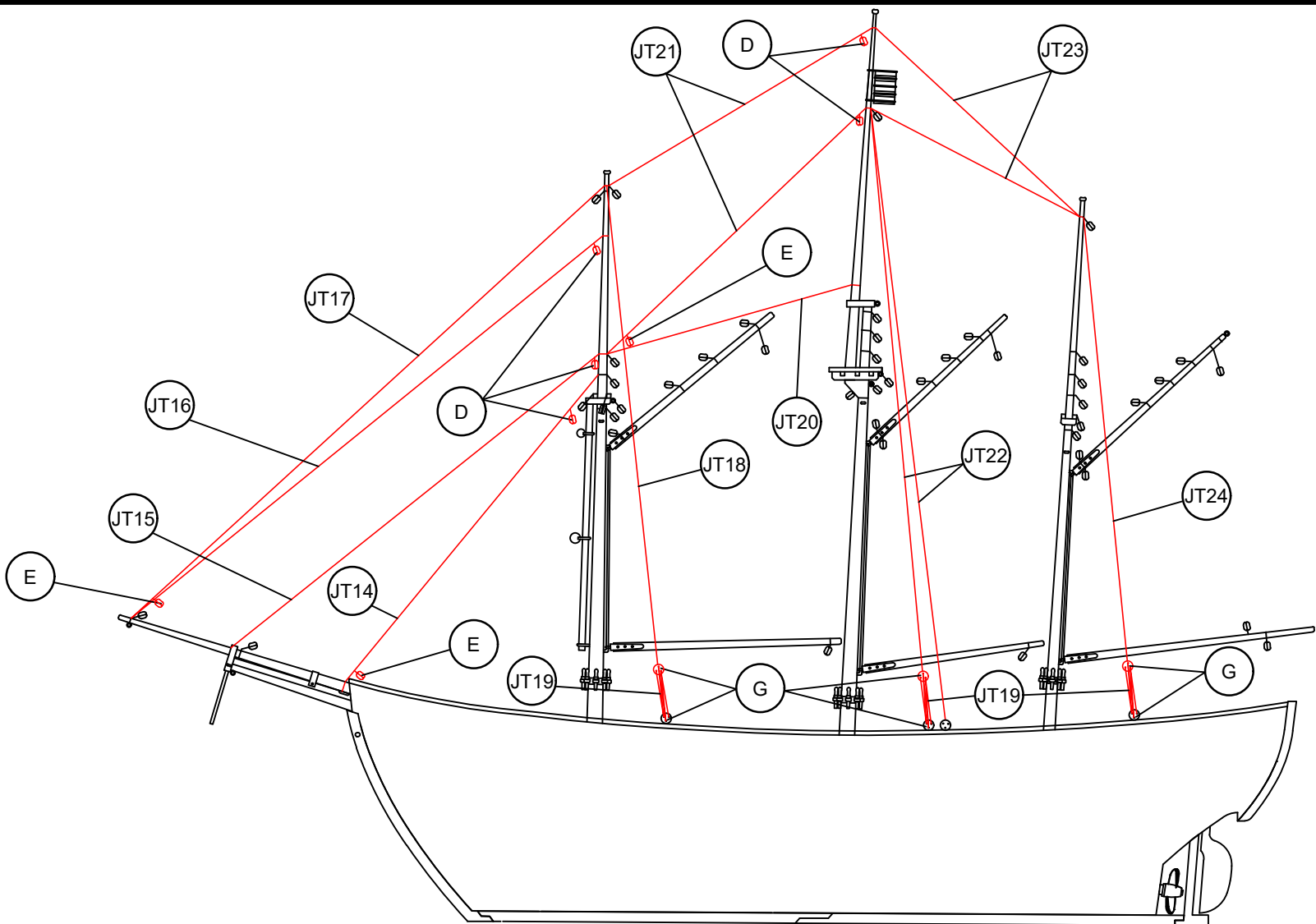

JT14	∅0,50x300	Hilo marrón / Brown thread / Fil brun / braunes Baumwollfaden / Filo marrone	JT21	∅0,50x300	Hilo marrón / Brown thread / Fil brun / braunes Baumwollfaden / Filo marrone
JT15	∅0,50x325	Hilo marrón / Brown thread / Fil brun / braunes Baumwollfaden / Filo marrone	JT22	∅0,50x800	Hilo marrón / Brown thread / Fil brun / braunes Baumwollfaden / Filo marrone
JT16	∅0,50x375	Hilo marrón / Brown thread / Fil brun / braunes Baumwollfaden / Filo marrone	JT23	∅0,50x225	Hilo marrón / Brown thread / Fil brun / braunes Baumwollfaden / Filo marrone
JT17	∅0,50x425	Hilo marrón / Brown thread / Fil brun / braunes Baumwollfaden / Filo marrone	JT24	∅0,50x700	Hilo marrón / Brown thread / Fil brun / braunes Baumwollfaden / Filo marrone
JT18	∅0,50x700	Hilo marrón / Brown thread / Fil brun / braunes Baumwollfaden / Filo marrone	D	4	Madera / Wood / Bois / Holz / Legno
JT19	∅0,15x250	Hilo marrón / Brown thread / Fil brun / braunes Baumwollfaden / Filo marrone	E	4	Madera / Wood / Bois / Holz / Legno
JT20	∅0,50x275	Hilo marrón / Brown thread / Fil brun / braunes Baumwollfaden / Filo marrone	G	5	Madera / Wood / Bois / Holz / Legno

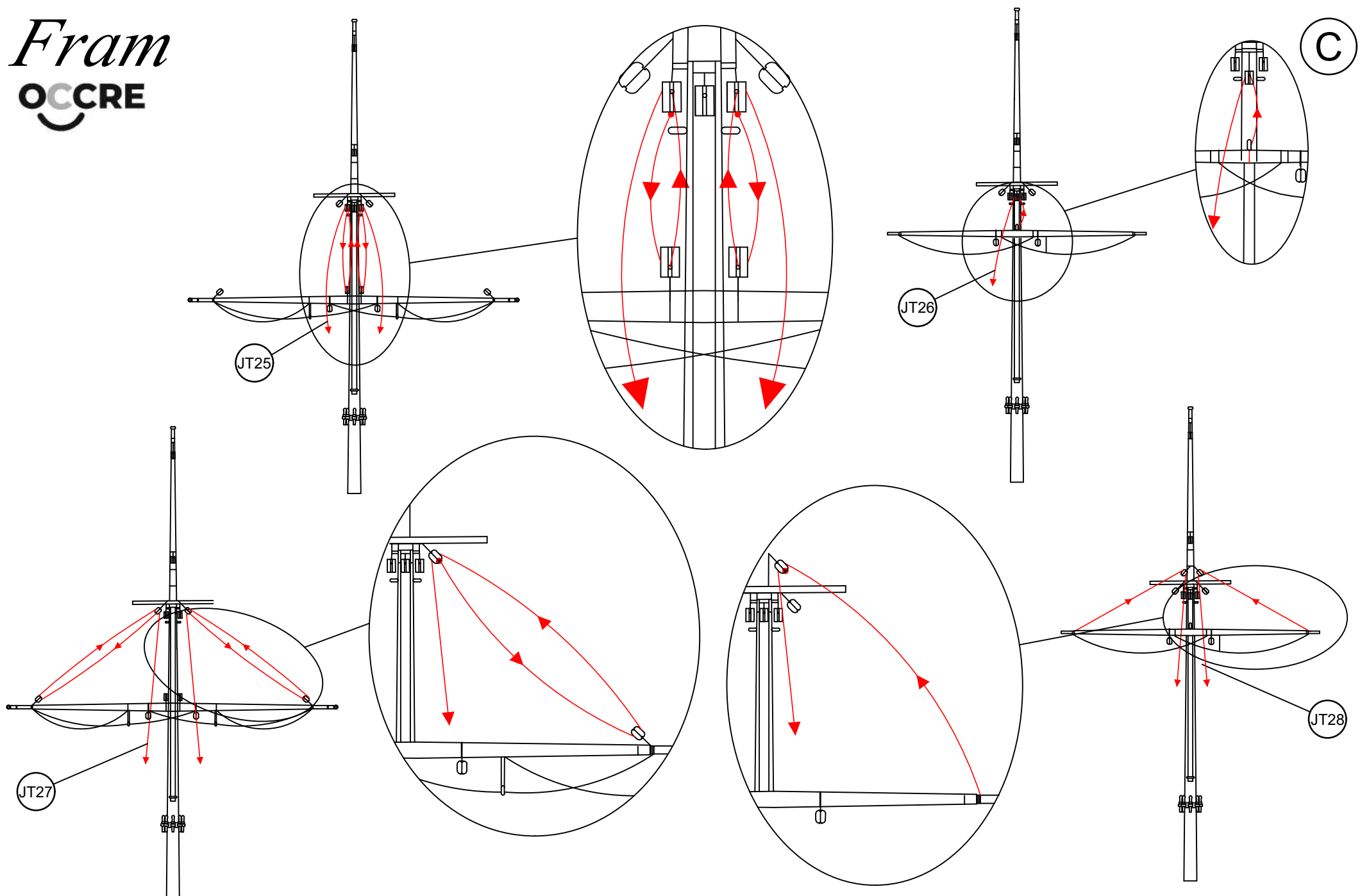

JT25	∅0,15x450	Hilo crudo / Raw thread / Fil brut / Rohes Baumwollfaden / Filo crudo	JT27	∅0,15x500	Hilo crudo / Raw thread / Fil brut / Rohes Baumwollfaden / Filo crudo
JT26	∅0,15x550	Hilo crudo / Raw thread / Fil brut / Rohes Baumwollfaden / Filo crudo	JT28	∅0,15x550	Hilo crudo / Raw thread / Fil brut / Rohes Baumwollfaden / Filo crudo

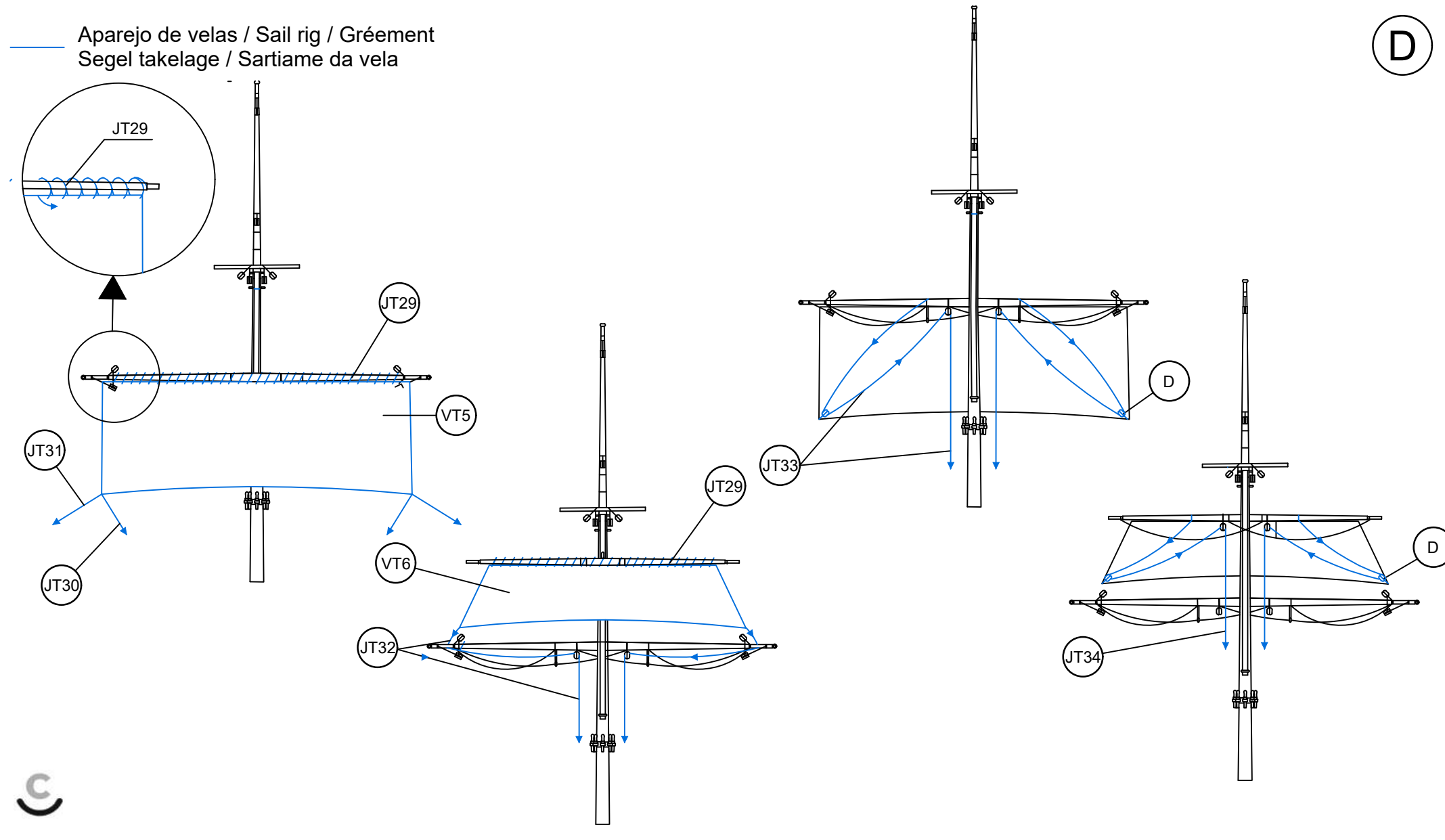

JT29	∅0,15x1000	Hilo crudo / Raw thread / Fil brut / Rohes Baumwollfaden / Filo crudo	JT32	∅0,15x400	Hilo crudo / Raw thread / Fil brut / Rohes Baumwollfaden / Filo crudo
VT5	Preformado / Preformed/ Préformé / Vorgeformt / Preformato	Tela / Cloth / Étoffe / Stoff / Tela	JT33	∅0,15x600	Hilo crudo / Raw thread / Fil brut / Rohes Baumwollfaden / Filo crudo
JT30	∅0,15x450	Hilo crudo / Raw thread / Fil brut / Rohes Baumwollfaden / Filo crudo	JT34	∅0,15x600	Hilo crudo / Raw thread / Fil brut / Rohes Baumwollfaden / Filo crudo
JT31	∅0,15x480	Hilo crudo / Raw thread / Fil brut / Rohes Baumwollfaden / Filo crudo	D	4	Madera / Wood / Bois / Holz / Legno
VT6	Preformado / Preformed/ Préformé / Vorgeformt / Preformato	Tela / Cloth / Étoffe / Stoff / Tela			

Aparejo de velas / Sail rig / Gréement
Segel takelage / Sartiamе da vela

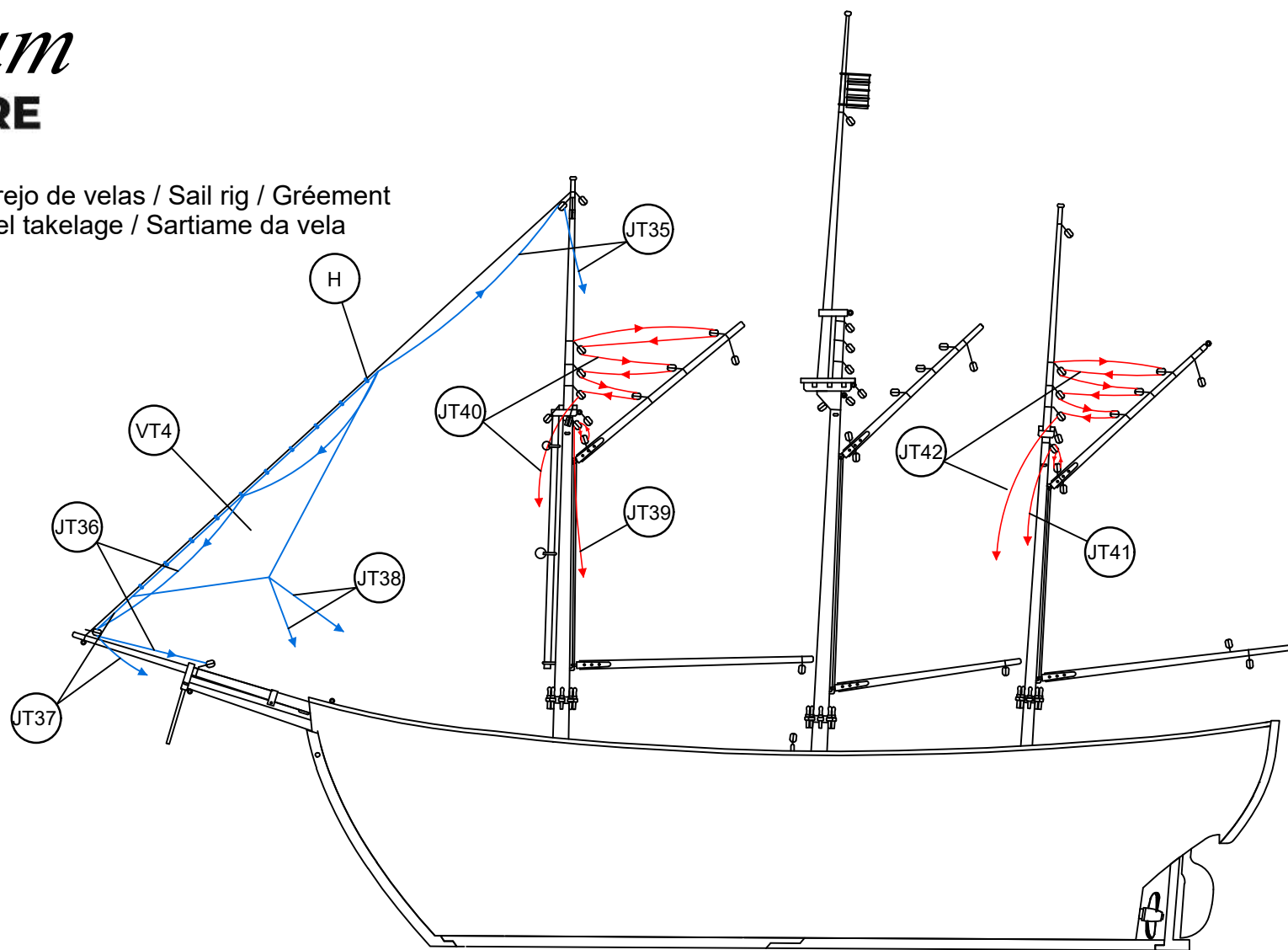

VT4	Preformado / Preformed/ Préformé / Vorgeformt / Preformato	Tela / Cloth / Étoffe / Stoff / Tela	JT39	ø0,15x500	Hilo crudo / Raw thread / Fil brut / Rohes Baumwollfaden / Filo crudo
JT35	ø0,15x500	Hilo crudo / Raw thread / Fil brut / Rohes Baumwollfaden / Filo crudo	JT40	ø0,15x600	Hilo crudo / Raw thread / Fil brut / Rohes Baumwollfaden / Filo crudo
JT36	ø0,15x600	Hilo crudo / Raw thread / Fil brut / Rohes Baumwollfaden / Filo crudo	JT41	ø0,15x500	Hilo crudo / Raw thread / Fil brut / Rohes Baumwollfaden / Filo crudo
JT37	ø0,15x300	Hilo crudo / Raw thread / Fil brut / Rohes Baumwollfaden / Filo crudo	JT42	ø0,15x450	Hilo crudo / Raw thread / Fil brut / Rohes Baumwollfaden / Filo crudo
JT38	ø0,15x300	Hilo crudo / Raw thread / Fil brut / Rohes Baumwollfaden / Filo crudo	H	ø3	Latón / Brass / Latón / Messing / Ottone

Aparejo de velas / Sail rig / Gréement
Segel takelage / Sartiamе da vela

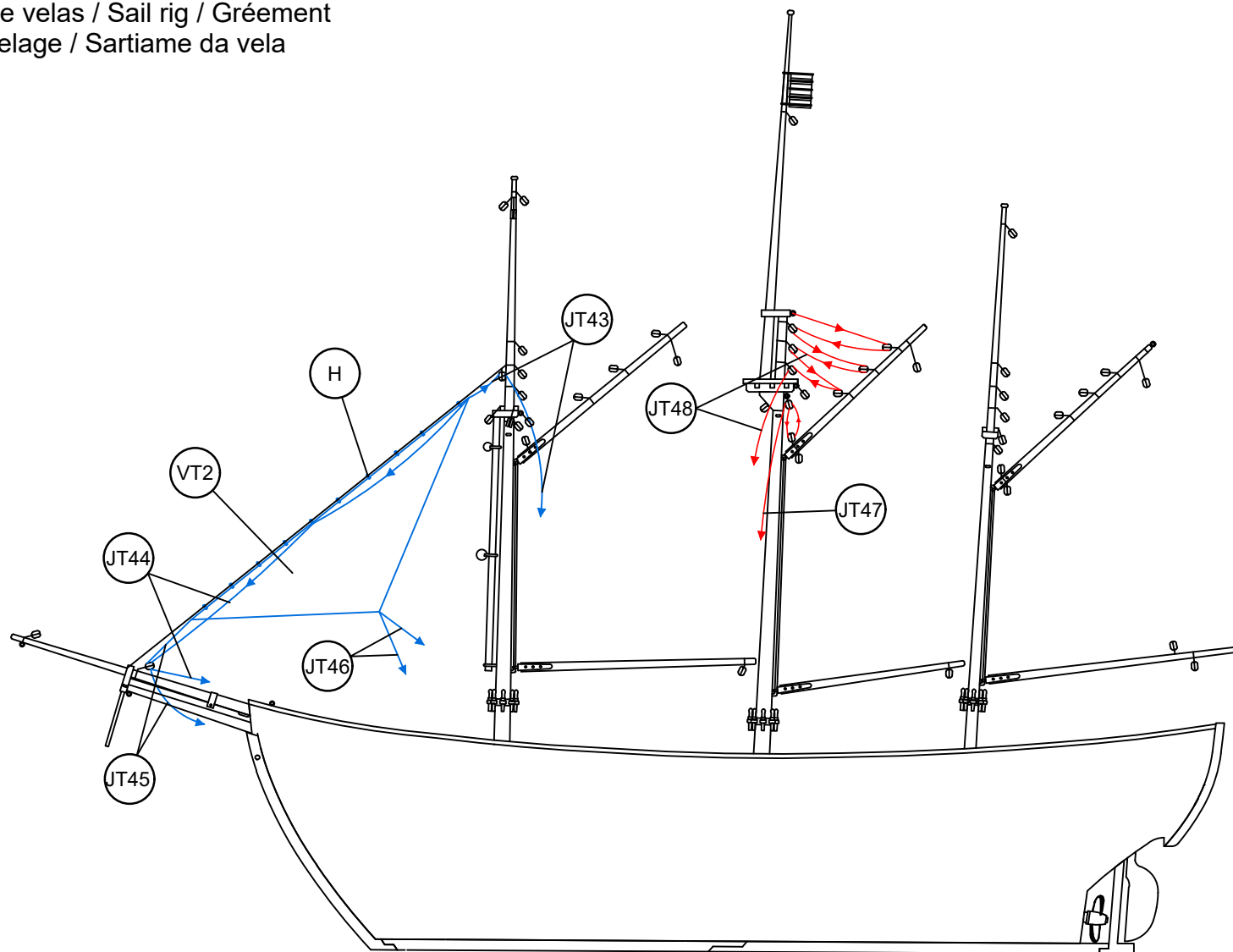

VT2	Preformado / Preformed/ Préformé / Vorgeformt / Preformato	Tela / Cloth / Étoffe / Stoff / Tela	JT46	ø0,15x300	Hilo crudo / Raw thread / Fil brut / Rohes Baumwollfaden / Filo crudo
JT43	ø0,15x500	Hilo crudo / Raw thread / Fil brut / Rohes Baumwollfaden / Filo crudo	JT47	ø0,15x500	Hilo crudo / Raw thread / Fil brut / Rohes Baumwollfaden / Filo crudo
JT44	ø0,15x550	Hilo crudo / Raw thread / Fil brut / Rohes Baumwollfaden / Filo crudo	JT48	ø0,15x400	Hilo crudo / Raw thread / Fil brut / Rohes Baumwollfaden / Filo crudo
JT45	ø0,15x300	Hilo crudo / Raw thread / Fil brut / Rohes Baumwollfaden / Filo crudo	H	ø3	Latón / Brass / Latón / Messing / Ottone

Aparejo de velas / Sail rig / Gréement
Segel takelage / Sartiamе da vela

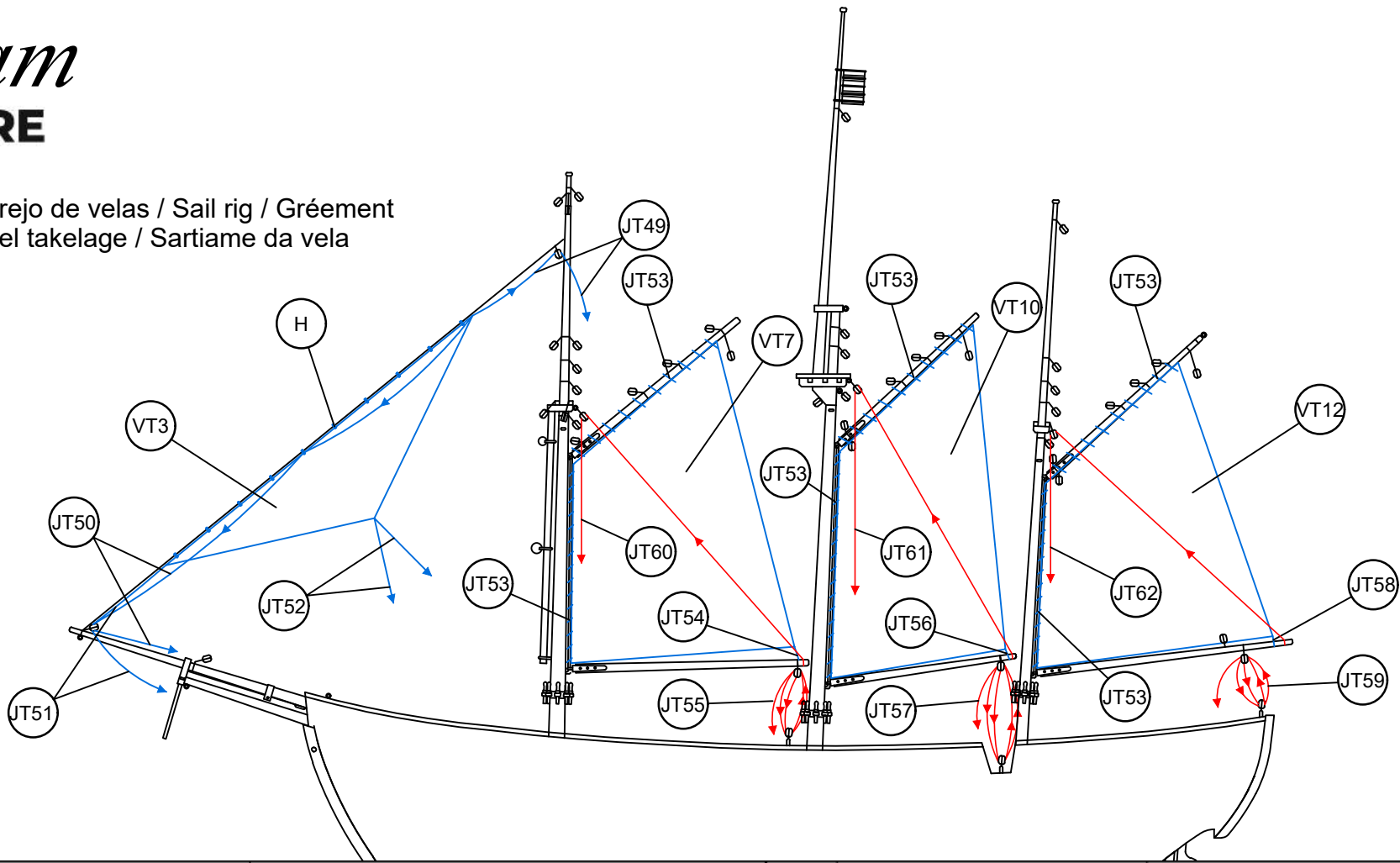

VT3	Preformado / Preformed/ Préformé / Vorgeformt / Preformato	Tela / Cloth / Étoffe / Stoff / Tela	JT55	ø0,15x350	Hilo crudo / Raw thread / Fil brut / Rohes Baumwollfaden / Filo crudo
JT49	ø0,15x500	Hilo crudo / Raw thread / Fil brut / Rohes Baumwollfaden / Filo crudo	JT56	ø0,15x100	Hilo crudo / Raw thread / Fil brut / Rohes Baumwollfaden / Filo crudo
JT50	ø0,15x500	Hilo crudo / Raw thread / Fil brut / Rohes Baumwollfaden / Filo crudo	JT57	ø0,15x350	Hilo crudo / Raw thread / Fil brut / Rohes Baumwollfaden / Filo crudo
JT51	ø0,15x300	Hilo crudo / Raw thread / Fil brut / Rohes Baumwollfaden / Filo crudo	JT58	ø0,15x100	Hilo crudo / Raw thread / Fil brut / Rohes Baumwollfaden / Filo crudo
JT52	ø0,15x280	Hilo crudo / Raw thread / Fil brut / Rohes Baumwollfaden / Filo crudo	JT59	ø0,15x350	Hilo crudo / Raw thread / Fil brut / Rohes Baumwollfaden / Filo crudo
JT53	ø0,15x1000	Hilo crudo / Raw thread / Fil brut / Rohes Baumwollfaden / Filo crudo	JT60	ø0,15x350	Hilo crudo / Raw thread / Fil brut / Rohes Baumwollfaden / Filo crudo
VT7	Preformado / Preformed/ Préformé / Vorgeformt / Preformato	Tela / Cloth / Étoffe / Stoff / Tela	JT61	ø0,15x450	Hilo crudo / Raw thread / Fil brut / Rohes Baumwollfaden / Filo crudo
VT10	Preformado / Preformed/ Préformé / Vorgeformt / Preformato	Tela / Cloth / Étoffe / Stoff / Tela	JT62	ø0,15x500	Hilo crudo / Raw thread / Fil brut / Rohes Baumwollfaden / Filo crudo
VT12	Preformado / Preformed/ Préformé / Vorgeformt / Preformato	Tela / Cloth / Étoffe / Stoff / Tela	H	ø3	Latón / Brass / Latón / Messing / Ottone
JT54	ø0,15x100	Hilo crudo / Raw thread / Fil brut / Rohes Baumwollfaden / Filo crudo			

Aparejo de velas / Sail rig / Gréement
Segel takelage / Sartiamе da vela

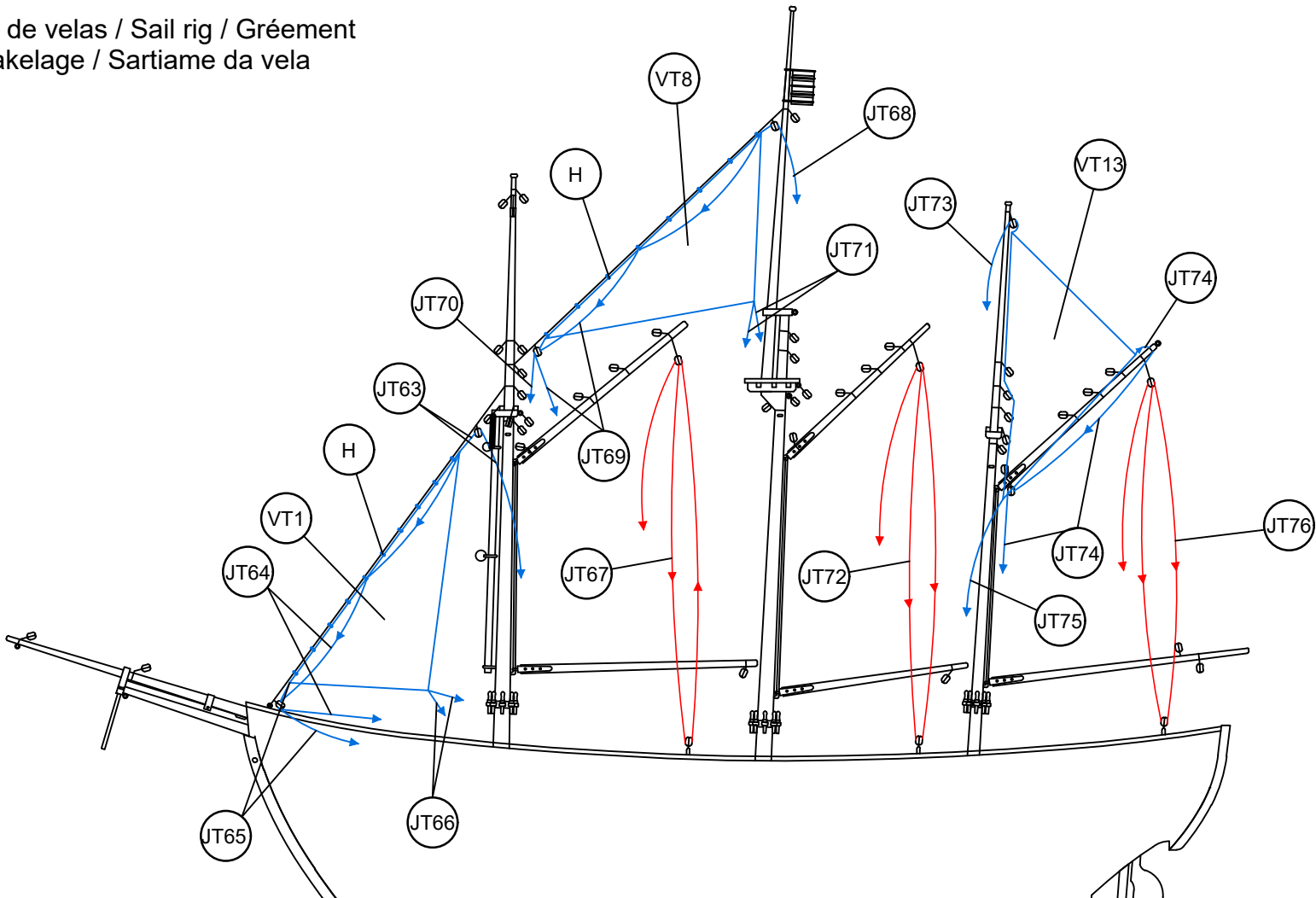

VT1	Preformado / Preformed/ Préformé / Vorgeformt / Preformato	Tela / Cloth / Étoffe / Stoff / Tela	JT70	ø0,15x400	Hilo crudo / Raw thread / Fil brut / Rohes Baumwollfaden / Filo crudo
JT63	ø0,15x350	Hilo crudo / Raw thread / Fil brut / Rohes Baumwollfaden / Filo crudo	JT71	ø0,15x300	Hilo crudo / Raw thread / Fil brut / Rohes Baumwollfaden / Filo crudo
JT64	ø0,15x500	Hilo crudo / Raw thread / Fil brut / Rohes Baumwollfaden / Filo crudo	JT72	ø0,15x700	Hilo crudo / Raw thread / Fil brut / Rohes Baumwollfaden / Filo crudo
JT65	ø0,15x300	Hilo crudo / Raw thread / Fil brut / Rohes Baumwollfaden / Filo crudo	JT73	ø0,15x400	Hilo crudo / Raw thread / Fil brut / Rohes Baumwollfaden / Filo crudo
JT66	ø0,15x275	Hilo crudo / Raw thread / Fil brut / Rohes Baumwollfaden / Filo crudo	VT13	Preformado / Preformed/ Préformé / Vorgeformt / Preformato	Tela / Cloth / Étoffe / Stoff / Tela
JT67	ø0,15x700	Hilo crudo / Raw thread / Fil brut / Rohes Baumwollfaden / Filo crudo	JT74	ø0,15x500	Hilo crudo / Raw thread / Fil brut / Rohes Baumwollfaden / Filo crudo
VT8	Preformado / Preformed/ Préformé / Vorgeformt / Preformato	Tela / Cloth / Étoffe / Stoff / Tela	JT75	ø0,15x375	Hilo crudo / Raw thread / Fil brut / Rohes Baumwollfaden / Filo crudo
JT68	ø0,15x600	Hilo crudo / Raw thread / Fil brut / Rohes Baumwollfaden / Filo crudo	JT76	ø0,15x700	Hilo crudo / Raw thread / Fil brut / Rohes Baumwollfaden / Filo crudo
JT69	ø0,15x600	Hilo crudo / Raw thread / Fil brut / Rohes Baumwollfaden / Filo crudo	H	ø3	Latón / Brass / Latón / Messing / Ottone

Aparejo de velas / Sail rig / Gréement
Segel takelage / Sartiamе da vela

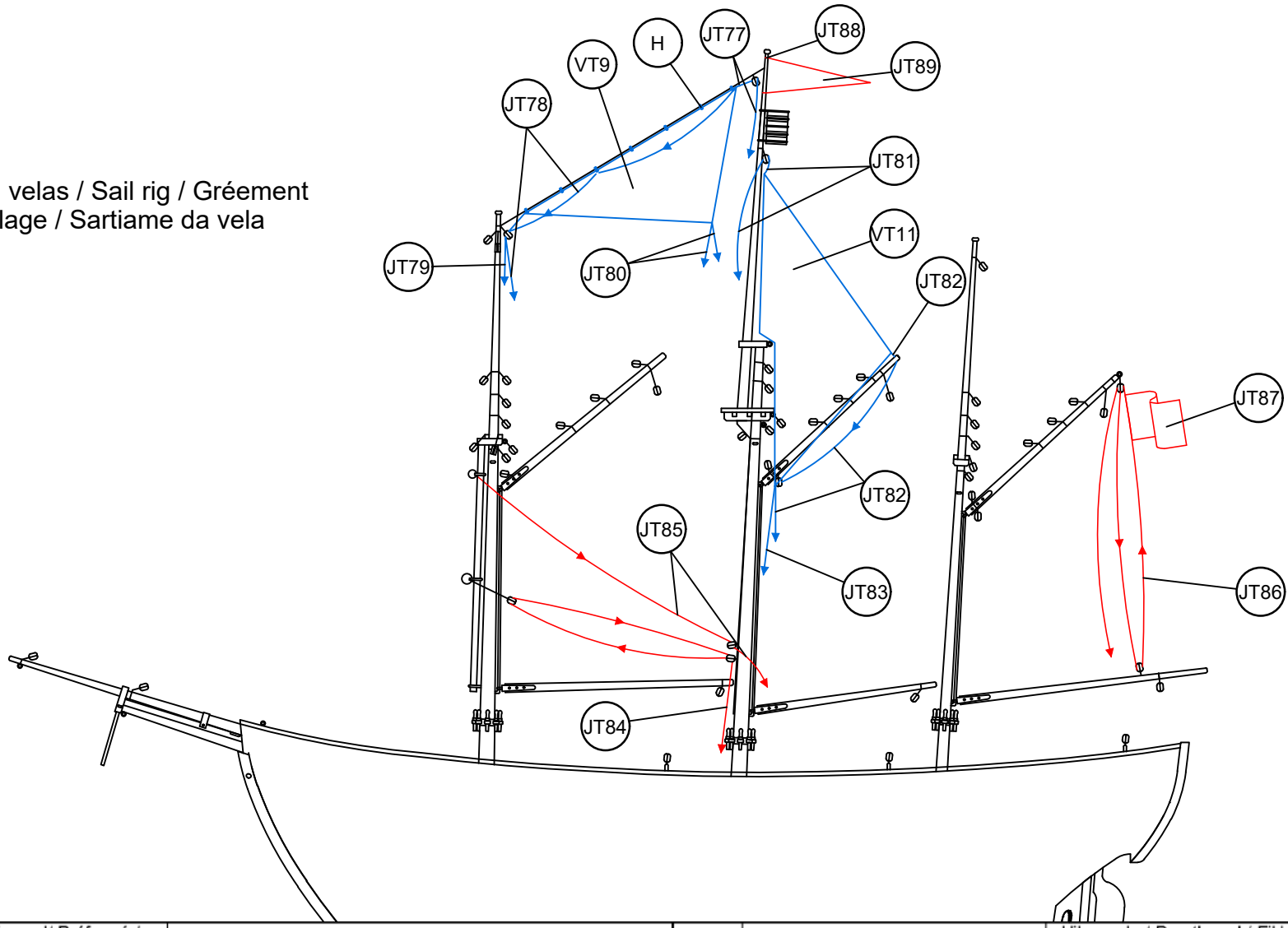

I

VT9	Preformado / Preformed/ Préformé / Vorgeformt / Preformato	Tela / Cloth / Étoffe / Stoff / Tela	JT83	ø0,15x350	Hilo crudo / Raw thread / Fil brut / Rohes Baumwollfaden / Filo crudo
JT77	ø0,15x500	Hilo crudo / Raw thread / Fil brut / Rohes Baumwollfaden / Filo crudo	JT84	ø0,15x600	Hilo crudo / Raw thread / Fil brut / Rohes Baumwollfaden / Filo crudo
JT78	ø0,15x500	Hilo crudo / Raw thread / Fil brut / Rohes Baumwollfaden / Filo crudo	JT85	ø0,15x500	Hilo crudo / Raw thread / Fil brut / Rohes Baumwollfaden / Filo crudo
JT79	ø0,15x400	Hilo crudo / Raw thread / Fil brut / Rohes Baumwollfaden / Filo crudo	JT86	ø0,15x600	Hilo crudo / Raw thread / Fil brut / Rohes Baumwollfaden / Filo crudo
JT80	ø0,15x350	Hilo crudo / Raw thread / Fil brut / Rohes Baumwollfaden / Filo crudo	JT87	Preformado / Preformed/ Préformé / Vorgeformt / Preformato	Tela / Cloth / Étoffe / Stoff / Tela
VT11	Preformado / Preformed/ Préformé / Vorgeformt / Preformato	Tela / Cloth / Étoffe / Stoff / Tela	JT88	ø0,15x200	Hilo crudo / Raw thread / Fil brut / Rohes Baumwollfaden / Filo crudo
JT81	ø0,15x400	Hilo crudo / Raw thread / Fil brut / Rohes Baumwollfaden / Filo crudo	JT89	Preformado / Preformed/ Préformé / Vorgeformt / Preformato	Tela / Cloth / Étoffe / Stoff / Tela
JT82	ø0,15x350	Hilo crudo / Raw thread / Fil brut / Rohes Baumwollfaden / Filo crudo	H	ø3	Latón / Brass / Latón / Messing / Ottone

Aparejo de velas / Sail rig / Gréement
Segel takelage / Sartiamе da vela

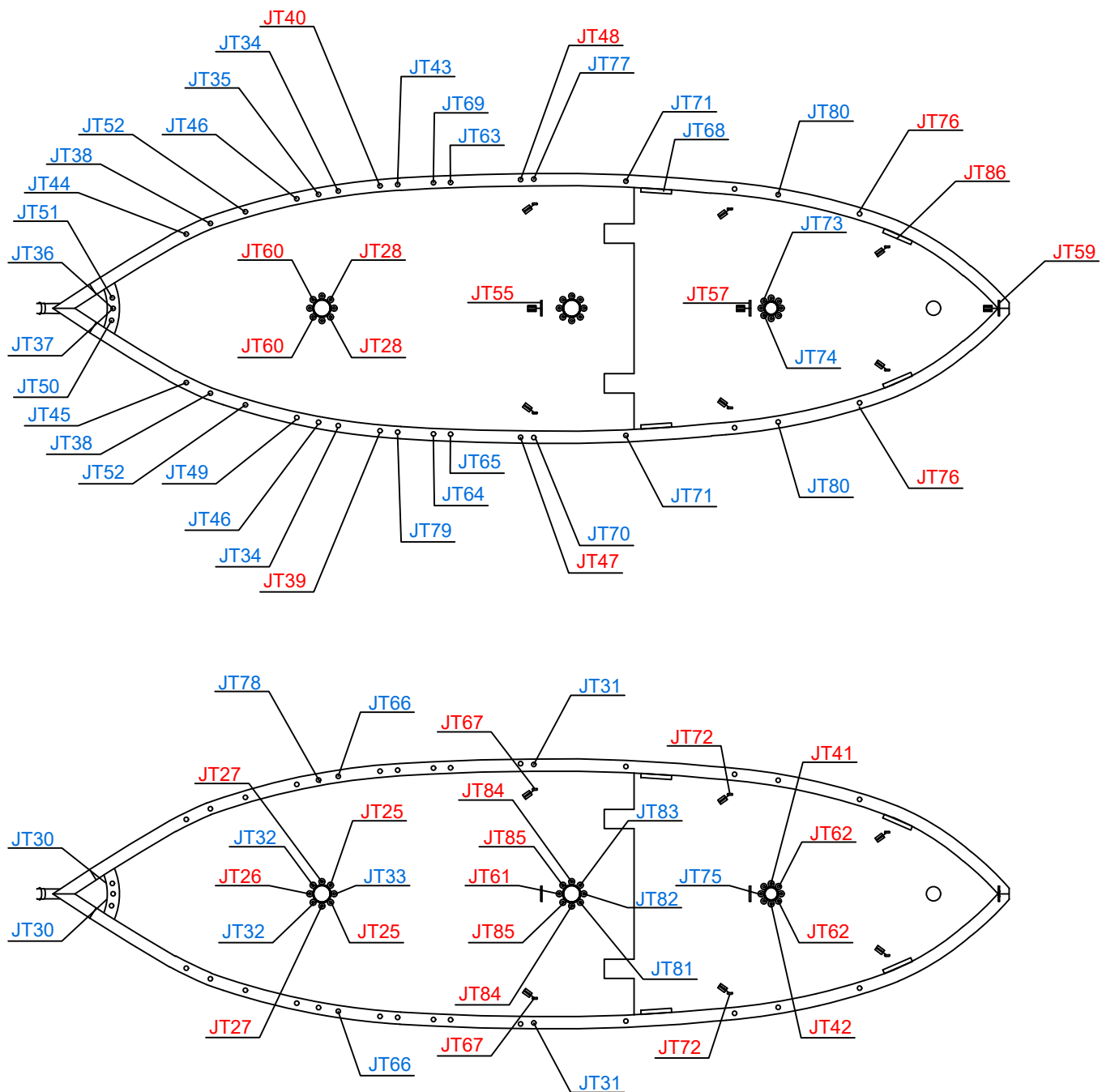

J