

OCCRE

CISNE NEGRO

Ref.12012

1

Instrucciones de montaje
Assembly instructions
Instructions de montage
Istruzioni di montaggio
Bastelanleitung



PREPARACIÓN DEL MATERIAL:

Para poder identificar correctamente las piezas pre-cortadas antes de extraerlas de las planchas de madera, marque en ellas la misma numeración que aparece en las hojas "IP".

INICIO DEL MONTAJE:

Con la ayuda de un cúter y procurando no colocar los dedos en la línea de corte, desprenda las piezas de las planchas eliminando los pequeños nervios que las sujetan. Seguidamente lije con suavidad las piezas con papel de lija de grano fino, para eliminar el repelo de las mismas. El orden numérico del paso a paso indica el orden de elaboración y colocación de las piezas. Es importante comprobar el ajuste de las piezas antes de pegarlas definitivamente. El grueso de los tableros puede variar medio milímetro de más o de menos.

LISTONES Y VARILLAS:

Los modelos incorporan varios tipos de listones y varillas para elaborar las diferentes piezas. La lista de piezas proporciona información sobre el tipo de material y medidas. En algunos casos es conveniente ajustar las medidas de las piezas sobre el propio modelo, conforme avance el montaje. De esta manera se consigue un mejor ajuste.

SERVICIO DE ATENCIÓN AL CLIENTE

Para cualquier duda o información sobre el montaje de nuestros productos, puede contactar con nuestro Servicio Técnico en la dirección: www.occre.com. Le atenderemos con mucho gusto.

A. Siguiendo el orden alfanumérico inserte y pegue las piezas indicadas en las figuras. Antes de encolar las cuadernas, verifique que encajan correctamente en su posición haciendo "tope" en los encajes correspondientes de la falsa quilla. Es importante que las cuadernas queden completamente perpendiculares a la falsa quilla para que posteriormente encajen bien las cubiertas. Para esta operación utilice como adhesivo cola blanca, (cola de carpintero. Ref.19200).

B. Trace una línea longitudinal que divida la cubierta B1 en dos mitades simétricas. Comience a forrar ajustando la primera tira a la línea de lápiz. Utilice como adhesivo cola de contacto, (cola de zapatero). Con el mango de madera de una herramienta, frote fuertemente las chapas contra la cubierta para que se adhieran con firmeza. Coloque la cubierta bocabajo y corte los sobrantes de las chapas. Después, trace unas líneas para simular la tablación. Lije la cubierta y aplíquele barniz satinado, (Ref.19419). Siga los mismos procedimientos para preparar las demás cubiertas. Ajuste y fije las cubiertas como le muestran las imágenes.

C. Forre los mamparos con las piezas C1 a C3. Después, corte los sobrantes de las chapas. Elabore y fije las piezas C4 a C10. Aplique barniz satinado, (Ref.19419), a las piezas de madera que vaya añadiendo. Ajuste y pegue las cubiertas y refuerzos indicados en las imágenes.

D. Coloque el casco boca abajo y comience a lijarlo, empezando desde proa y avanzando hacia popa. Debe desbastar las aristas de las cuadernas, pero sin deformar su forma original. El lijado del casco ha de quedar simétrico, es decir, que el lateral derecho ha de quedar igual que el izquierdo. También debe lijarse los refuerzos de proa y de popa. El lijado debe ser progresivo y suave. Compruebe con un listón, que el lijado es correcto. Para ello, debe deslizar el listón, sobre las cuadernas, para ver como se ajusta a su forma. Sumerja en agua las piezas D3 para que recuperen flexibilidad y poder curvarlas sin que se rompan. Las piezas D3, puede teñirlas con tinte de color nogal, (Ref.19421), o no teñirlas y pintarlas de color negro más adelante. Apique cola y pegue las piezas D3 a ambos lados del casco. Fíjelas mediante puntas A. Para este proceso puede utilizar un clavador, (Ref.19108), o un martillo.

E-F. Encole y fije las piezas E1 a ambos lados del casco. Después, pegue las piezas E2 por la parte interior de las aberturas de las piezas E1. Estas piezas son los fondos para más adelante fijar los cañones de la batería inferior. Continúe añadiendo las piezas que le muestran las imágenes. Es aconsejable que humedezca y curve las piezas E4 antes de fijarlas de forma definitiva. Es importante que aplique cola a las piezas E4 para que se fijen a las cuadernas y entre ellas. Fije las piezas E4 mediante puntas A. A medida que vaya avanzando con el forrado del casco, corte las piezas en la parte delantera del casco, dejando un espacio de 5mm de ancho. En la parte de popa, córtelas a ras del casco. Elabora piezas a medida y encóclelas para cerrar los huecos del forro del casco.

G-H-I. Lime las cabezas de las puntas hasta que queden enrasadas con el forro. Después, lije todo el casco. Debe quedar suave y sin desniveles.

Utilizando como adhesivo, cola de contacto, (cola de zapatero), coloque el forro G1 y G2. Este segundo forro, se coloca de la misma manera que el primero. Debe cerrar los huecos con cuñas y frotar las chapas con firmeza para que se adhieran al casco. A medida que avance con el forro, abra los orificios que las amuradas llevan de origen. Procure que las tiras de forro queden lo más juntas posible para conseguir un buen acabado. Continúe el forrado del casco hasta completarlo. Después, lije todo el casco con lija de grano fino para dejar su superficie uniforme. Elabore y pegue las piezas que le indican las imágenes. Después aplique barniz, (Ref.19419).

J-K-L. Utilice una herramienta para elaborar los rebajes que le indica la imagen a un listón J1. Después, pegue los listones J1 a ambos lados del barco. Ajuste y pegue las piezas J1, a J4. Elabore y pegue las piezas J5 a J13. Para las zonas curvas del casco, corte las piezas J8 y después de pegarlas, líjelas para dejarlas con el ancho requerido. Elabore y fije las piezas K1 a K8. Ranure un listón para elaborar las piezas L1. Corte a medida las piezas y añádalas al casco. Continúe añadiendo las piezas que indican las imágenes. Después, aplique barniz, (Ref.19419), a todo el casco. Barnice todas aquellas piezas de madera que vaya añadiendo al casco.

M-N. Construya la balconada con las piezas M1 a M10. Después, lije el conjunto obtenido. Compruebe y adapte el conjunto al casco. Enmasille las uniones de las piezas con masilla, (Ref.19143). Después, lije para igualar las superficies. Forre los tejados con las piezas M11 a M13. Ajuste y pegue las piezas M14 a M20. Utilice un taladro y unas pinzas para trenzar dos hilos de latón dobles. Corte a medida y pegue las piezas N1 a N6. Pinte la balconada de color negro, (Ref.19196). Después, lije los acetados para dejarlos velados. Corte a medida y pegue los acetados por el interior de la balconada, con cola blanca. Lije la pala del timón N9 para darle forma. Ajuste la forma y medida de las bisagras N10 y fíjelas al timón mediante puntas A, y pegamento rápido. Deberá ajustar la longitud de las puntas con unos alicates de corte. Ajuste y fije la pala del timón al casco mediante puntas A.

O-P. Si desea pintar el casco del barco como le indicamos a continuación, deberá lijarse previamente. Utilice papel de lija de grano fino para lijarse todas las piezas que vaya a pintar. Después, límpiolo eliminando el polvo resultante del pulido. Utilice cinta de carrocería para aislar y proteger la zona que no desee pintar. Aplique pintura de color negro, (Ref.19396), a la parte superior del casco. Pinte la parte inferior del casco de color blanco, (Ref.19395). Cuando la pintura se haya secado, aplique betún de Judea, (Ref.19417), a la parte inferior del casco. Este producto puede aplicarlo directamente o diluirlo si lo desea. O puede aplicarlo directamente y después, si lo desea, con un paño húmedo puede aclararlo. Para pintar las piezas metálicas, previamente deberá limpiar las piezas con alcohol y aplicarles imprimación, (Ref.19418). Pinte las piezas de color negro, (Ref.19396), y después, aplique pintura de color oro, (Ref.19408), a pincel seco. Vaya construyendo y añadiendo al barco, las piezas y conjuntos que le indican las imágenes. Aplique betún de Judea, (Ref.19417), a las cubiertas y mamparos para conseguir un acabado envejecido.

Q-R. Inserte entre si las piezas Q1 para construir un enjaretado. Después, córtelo a medida y elabore su marco. Elabore y barnice las piezas que le muestran las imágenes. Después, aplíqueles betún de Judea para igualar el acabado con las cubiertas. Continúe construyendo y fijando piezas. Utilice la plantilla PL-01 para posicionar las piezas en las cubiertas. Para construir el cabrestante puede utilizar la varilla MT31 para alinear las piezas.

S. Extraiga las piezas que formarán la barca y tíñalas con tinte de color nogal, (Ref.19421). Construya el esqueleto de la barca con las piezas S1 a S10. Después, lije las cuadernas y refuerzos. Forre el esqueleto con las piezas S11. Complete la barca con las piezas S12 a S19. Después, barnice la barca y aplíquele betún de Judea.

T-U. Pegue las anclas con los cepos y decore los conjuntos obtenidos. Añada los componentes que le indican las imágenes. Construya la lumbrera y decórela de color negro por fuera y blanco por dentro. Pegue los acetados T10 por el interior de las piezas T9. Pegue los tejados de la lumbrera. Tíñe las piezas T12 a T14 con tinte nogal, (Ref.19421), después, construya el conjunto. Decore el rótulo del nombre y péguelo como le muestra la imagen. Anude las vigotas F y G con el hilo U1. Inserte las vigotas por las mesas de guarnición y fíjelas mediante puntas A. Añada las piezas que le indican las imágenes.

ARBOLADURA

Para elaborar los mástiles, el primer paso a seguir será cortar las varillas según las medidas que indica la lista de piezas, o bien tomarlas directamente de los planos que están impresos a escala 1/1.

Todos los mástiles y vergas tienen cierta conicidad que se deberá realizar.

Para realizar la conicidad a los mástiles, lije las varillas, (con un lijador), aumentando el desgaste de ésta a medida que se acerca al extremo donde se quiere disminuir el diámetro.

Haga rodar la varilla para que el desgaste sea igual por todo el contorno hasta conseguir llegar al diámetro que indica el plano.

Para elaborar la conicidad de las vergas, realice las mismas operaciones, pero esta vez a ambos extremos de la varilla.

Deberá teñir o pintar las varillas en función del modelo que esté construyendo.

Para realizar correctamente los mástiles de este modelo se deberá tener en cuenta:

- Los planos
- Las fotos de detalle de los mástiles
- Las medidas y descripción de materiales de la lista de piezas
- Las hojas "IP" de identificación de piezas
- La plantilla PL-01

Los mástiles se deberán barnizar y algunas de las piezas que los componen se deberán pintar. Véanse las fotos generales de detalle de los mástiles.

Una vez montados y barnizados, deberán colocarse los aparejos, (estobos, cuadernales, cáncamos, motones, etc.), y fijarlos al barco.

Los mástiles se deben introducir hasta hacer tope en los encajes de la falsa quilla.

JARCIA

Para elaborar la jarcia de este barco, siga el orden alfabético de las figuras impresas de los planos, que indican el orden de colocación: de hilos, vigotas, motones, velas, etc, destacados en color rojo. La lista de piezas le orientará sobre el tipo de materiales y medidas a utilizar.

Para simular el envejecido de las velas, se les puede dar un baño con infusión de té, sin hacerlas hervir, y dejarlas secar bien arrugadas.

Se colocaran sin planchar para que tengan cuerpo.

PREPARING THE MATERIAL:

In order to correctly identify the precut parts, before removing them from the wooden sheets, mark on them the same numbers that appear on the "IP" sheets.

STARTING THE ASSEMBLY:

Using a cutter, and making sure you do not put your fingers along the cutting line, remove the parts from the wooden sheets, eliminating the small sprues that hold them in place. In continuation smoothly sand down the parts, using fine grain sandpaper, to eliminate the pickup of the parts. The numerical order indicates the order in which the different parts must be made up and fitted.

STRIPS AND RODS:

These models incorporate a variety of different types of strips and rods with which to make up different parts of the kit. The list of parts proportions information on the type of material and measurements. In some cases it is advisable to adjust the measurements on the basis of the model itself, as assembly progresses. In this way you will achieve a better fit. The thickness of the boards can vary by half a millimeter more or less.

CUSTOMER ATTENTION SERVICE:

In the case of whatsoever doubt or further information that you may require regarding the assembly of our products, please contact our Technical Service online at the address: www.occre.com. We will be delighted to attend to you.

A. Following the alphanumeric order insert and glue the parts as shown in the illustrations. Before gluing the frames, check that they fit correctly in their position by fitting them into the corresponding sockets of the false keel. It is important that the frames are completely perpendicular to the false keel so that the decks fit well afterwards. For this operation, use white glue (carpenter's glue). Ref 19200).

B. Draw a longitudinal line that divides deck B1 into two symmetrical halves. Start lining by fitting the first strip to the pencil line. Use contact glue, (shoemaker's glue). Using the wooden handle of a tool, rub the strips firmly against the cover so that they adhere firmly. Place the deck upside down and cut the leftovers from the sheets. Then, draw some lines to simulate the planking. Sand the cover and apply satin varnish, (Ref.19419). Follow the same procedures to prepare the other decks. Adjust and secure the decks as shown in the images.

C. Line the bulkheads with parts C1 to C3. Then, cut the excess from the plates. Assemble and fit parts C4 to C10. Apply satin varnish, (Ref.19419), to the wooden pieces that you fit. Adjust and glue the decks and reinforcements shown in the illustrations.

D. Place the hull upside down and start sanding starting from bow to stern. You must roughen the edges of the frames, but without spoiling their original shape. Sanding the hull must be symmetrical; that is, the right side must be identical to the left. You should also sand the bow and stern reinforcements. Sanding must be progressive and smooth. Use a straight edge to check that the sanding is correct. To do so, you must slide the edge over the frames, to see how it fits its shape. Soak parts D3 in water to make them flexible and can bend without breaking. You can dye parts D3 with walnut colour dye, (Ref.19421), or not dye them and paint them black later. Apply glue and stick the D3 parts on both sides of the hull. Secure them with A pins. For this process you can use a nailing tool, (Ref.19108), or a hammer.

E-F. Glue and fit parts E1 to both sides of the hull. Then, stick the E2 parts to the inside of the E1 part openings. These parts are the bases for later fixing the cannons of the lower battery. Continue fitting the pieces shown in the illustrations. It is advisable to moisten and bend the E4 parts before fixing them permanently. It is important that you apply glue to the E4 parts so that they stick to the frames and each other. Secure the E4 pieces using A pins. As you progress with the hull lining, cut the pieces at the front of the hull, leaving a 5mm wide space. At the stern, cut them flush with the hull. Prepare custom pieces and glue them to close the gaps in the hull lining.

G-H-I. File the heads of the pins until they are flush with the lining. Then, sand the entire hull. It should be smooth and even.

Using contact glue as adhesive (shoemaker's glue), fit the G1 and G2 lining. This second lining is placed in the same way as the first. You must close the gaps with wedges and firmly rub the plates so that they adhere to the hull. As you proceed with the lining, open the holes that the bulwarks originally have. Ensure that the lining strips are as close together as possible to achieve a good finish. Continue lining the hull until it is complete. Then, sand the entire hull with fine-grain sandpaper to make its surface smooth and even. Assemble and stick the pieces as shown by the illustrations. Then apply varnish, (Ref.19419).

J-K-L. Use a tool to make the notches indicated by the image on a J1 slat. Then, stick the J1 slats on both sides of the boat. Adjust and glue parts J1 to J4. Assemble and fit parts J5 to J13. For the curved areas of the hull, cut parts J8 and after gluing them, sand them to the required width. Assemble and fit parts K1 to K8. Slot a strip to make the L1 parts. Cut the pieces to size and add them to the hull. Continue fitting the pieces shown in the illustrations. Then, apply varnish (Ref.19419) to the entire hull. Varnish all the wooded parts you fit to the hull.

M-N. Build the balcony using parts M1 to M10. Then, sand them. Check and adjust the set to the hull. Seal the joints of the pieces with putty, (Ref.19143). Then, sand to even out the surfaces. Line the roofs with the M11 to M13 pieces. Adjust and glue parts M14 to M20. Use a drill and pliers to twist two double brass wires. Cut to size and stick parts N1 to N6. Paint the balcony black, (Ref.19196). Then, sand the acetate sheets to leave them translucent. Cut to size and stick the acetates on the inside of the balcony, using white glue. Sand the rudder blade N9 to shape it. Adjust the shape and size of the N10 hinges and fit them to the rudder using A pins and instant glue. You will need to adjust the length of the pins with wire cutters. Adjust and secure the rudder blade to the hull using A pins.

O-P. If you wish to paint the boat's hull as shown below, you must sand it beforehand. Use fine-grain sandpaper to sand all the pieces you are going to paint. Then, clean it by removing the dust resulting from the polishing. Use masking tape to isolate and protect the area you do not wish to paint. Apply black paint, (Ref.19396), to the upper part of the hull. Paint the bottom part of the hull white, (Ref.19395). Once the paint has dried, apply bitumen of Judea, (Ref.19417), to the lower part of the hull. You can apply this product directly or dilute it if you wish. You can apply it directly and then, if you wish, you can wipe it with a damp cloth. To paint the metal parts, you must first clean them with alcohol and apply a primer (Ref.19418). Paint the pieces black (Ref.19396) and afterwards, apply gold paint, (Ref.19408), with a dry brush. Continue building and the ship and adding the pieces and sets shown in the illustrations. Apply bitumen of Judea (Ref.19417) to the decks and bulkheads to achieve an aged finish.

Q-R. Fit parts Q1 together to construct a grating. Then, cut it to size and make the frame. Prepare and varnish the pieces shown in the illustrations. Then, apply bitumen of Judea to match the finish of the decks. Continue building and fitting pieces. Use template PL-01 to position the parts on the decks. To assemble the winch, use the MT31 rod to align the parts.

S. Extract the pieces that will make the boat and stain them with walnut-coloured dye, (Ref.19421). Build the skeleton of the boat using parts S1 to S10. Then, sand the frames and reinforcements. Line the framing with parts S11. Complete the boat using parts S12 to S19. Then, varnish the boat and apply bitumen of Judea to it.

T-U. Stick the anchors and their stocks and paint the completed item. Add the components as shown in the illustrations. Build the skylight and paint it black on the outside and white on the inside. Stick the T10 acetates on the inside of the T9 parts. Stick the roofs of the skylight. Stain parts T12 to T14 with walnut dye, (Ref.19421), then, assemble them. Decorate the escutcheon and stick it as shown in the picture. Join deadeyes F and G using U1 thread. Insert the deadeyes through the chain-wales and secure them using A pins. Fit the parts as shown in the illustrations.

MASTS AND SPARS

In order to make up the masts the first step is to cut the rods to size, as indicated in the parts list, or by taking measurements directly from the plans, which are printed in 1/1 scale.

All of the masts and spars have to have a certain conical shape, which they will have to be given.

In order to achieve this conical shape for the masts, sand down the rod (using a sander), increasing the amount of sanding down as you get closer to the end at which you want to decrease the diameter. Turn the rod so that you sand it down evenly on all sides, until achieving the diameter indicated in the plan.

To achieve this conical shape for the spars carry out the above operations but in this case evenly reducing the diameter at both ends of the rod.

The rods will have to be stained or painted, depending on the model that you are building.

To correctly make up the mast for this model you must take into account:

- The plans
- The close-up photos of the masts and spars
- The measurements and material descriptions of the parts list
- The "PI" parts identification sheets
- Template PL-01

The masts and spars need to be varnished, while some of the parts that make them up are meant to be painted. Examine the general and close-up photos of the masts

Once the mast and spars has been assembled and varnished fix the tackle (slings, blocks, eyebolts, clump blocks, etc.) into place on the ship. The masts will have to be fully inserted into the sockets prepared to receive them in the false keel.

SAILS AND RIGGING

In order to make up the running gear for this ship follow the alphabetic order of the images printed on the plans, indicating the order for fitting the (ropes, clump blocks, blocks, sails, etc.) highlighted in red. In combination with the parts list this will serve as a guide with regard to the type of material to be used and the measurements.

A method for simulating the aging of the sails is to soak them in an infusion of tea, without boiling, and then leaving them to dry all wrinkled up. Fit them in place without ironing so that they will have a certain consistency.

PRÉPARATION DU MATÉRIEL :

Pour pouvoir identifier correctement les pièces prédécoupées, avant de les extraire des planches de bois, inscrivez sur elles la même numérotation qui apparaît sur la page « IP ».
L'épaisseur des planches peut varier d'un demi-millimètre plus ou moins.

DÉBUT DU MONTAGE :

À l'aide d'un cutter, et en essayant de ne pas poser les doigts sur la ligne de découpe, séparez les pièces des planches en éliminant les petits nerfs qui les retiennent. Puis poncez doucement les pièces à l'aide d'un papier de verre à grain fin, pour éliminer le contrefil. L'ordre numérique des étapes photographiques et des plans indique l'ordre d'élaboration et d'installation des pièces.

LISTEAUX ET BAGUETTES :

Les modèles intègrent plusieurs types de listeaux et de baguettes destinés à confectionner les différentes pièces. La liste de pièces indique le type de matériau et les dimensions des pièces. Il est parfois recommandé d'ajuster les mesures sur le modèle lui-même, au fur et à mesure que nous avançons dans le montage. De cette manière, on obtient un meilleur réglage.

SERVICE CLIENT :

Pour toute question ou information concernant le montage de nos produits, vous pouvez contacter notre Service Technique à l'adresse suivante :
www.occre.com. Nous répondrons avec plaisir à vos questions.

A. Suivant l'ordre alphanumérique, insérez et collez les pièces indiquées sur les figures. Avant de coller les couples, vérifiez qu'ils s'ajustent correctement à leur place et font office de « taquet » dans les emboîtements correspondants de la fausse quille. Il est important que les couples restent totalement perpendiculaires à la fausse quille afin que les ponts viennent s'emboîter correctement par la suite. Pour cette opération, utilisez comme adhésif de la colle blanche (colle de menuisier. Réf. 19200).

B. Tracez une ligne longitudinale divisant le pont B1 en deux moitiés symétriques. Commencez à border en faisant suivre la première rangée sur la ligne tracée au crayon. Utilisez la colle de contact (colle de cordonnier). À l'aide du manche en bois d'un outil, frottez fortement la planche contre le pont pour qu'elle y adhère fermement. Renversez le pont et découpez les excédents de plaques. Puis tracez des lignes et des points pour simuler le bordage. Poncez le pont et appliquez le vernis satiné (Réf. 19419). Suivez la même procédure pour préparer les autres ponts. Ajustez et fixez les ponts comme le montrent les images.

C. Bordez les cloisons à l'aide des pièces C1 à C3. Puis, découpez les excédents des plaques. Confectionnez et fixez les pièces C4 à C10. Appliquez du vernis satiné (Réf. 19419), sur les pièces en bois au fur et à mesure que vous les posez. Ajustez et collez les ponts et les renforts comme indiqué sur les images.

D. Placez la coque à l'envers et commencez à poncer en commençant par la proue et en avançant vers la poupe. Il faudra dégrossir les arêtes des couples, mais sans en altérer la forme originale. Le ponçage de la coque doit être symétrique, c'est à dire que le côté droit doit être identique au gauche. Les renforts de proue et de poupe doivent être poncés également. Le ponçage doit être progressif et doux. Vérifiez à l'aide d'un listeau que le ponçage est correct. Pour cela, faites glisser le listeau sur les couples pour vérifier qu'il s'ajuste à leur forme. Plongez les pièces D3 dans l'eau pour qu'elles récupèrent en flexibilité et pouvoir les courber sans qu'elles se cassent. Les pièces D3 peuvent être colorées avec de la teinte couleur noyer (Réf. 19421), ou ne pas les teinter et les peindre de couleur noire plus tard. Appliquez de la colle et collez les pièces D3 de part et d'autre de la coque. Fixez-les à l'aide des pointes A. Pour cette opération, vous pouvez utiliser un marteau de cloueur (Réf. 19108) ou un marteau simple.

E-F. Collez et fixez les pièces E1 de part et d'autre de la coque. Puis, collez les pièces E2 par la partie intérieure des ouvertures des pièces E1. Ces pièces constituent un fond pour ensuite fixer les canons de la batterie inférieure. Continuez à ajouter les pièces indiquées sur les images. Il est conseillé d'humidifier et de courber les pièces E4 avant de les fixer de manière définitive. Il est important d'appliquer la colle sur les pièces E4 afin qu'elles soient fixées sur les couples et entre elles. Fixez les pièces E4 à l'aide de pointes A. À mesure que vous avancez avec le bordage de la coque, découpez les pièces de la partie avant de la coque, en laissant un espace de 5 mm de large. Sur la partie de la poupe, découpez-les au ras de la coque. Élaborez des pièces sur mesure et collez-les pour refermer les creux dans le bordé de la coque.

G-H-I. Limez les têtes des pointes, jusqu'à ce qu'elles restent au niveau du bordé. Puis poncez toute la coque. Elle doit être douce et régulière.

En utilisant comme adhésif de la colle de contact (colle de cordonnier), placez le bordé G1 et G2. Ce deuxième bordé est placé de la même manière que le premier. Il faut refermer les orifices avec des cales et frotter les planches fermement pour qu'elles adhèrent à la coque. À mesure que vous avancez avec le bordé, ouvrez les orifices que les pavois ont d'origine. Faites en sorte que les lattes du bordé restent le plus jointes possible afin d'obtenir une belle finition. Poursuivez le bordage de la coque jusqu'à ce qu'il soit complet. Puis, poncez toute la coque à l'aide d'une éponge de ponçage à grain fin pour laisser une surface uniforme. Élaborez et décorez les pièces indiquées sur les images. Ensuite, appliquez dessus du vernis (Réf. 19419).

J-K-L. Utilisez un outil pour élaborer les rainures comme indiqué sur l'image sur un listeau J1. Puis, collez les listeaux J1 de part et d'autre du bateau. Ajustez et collez les pièces J1 à J4. Élaborez et collez les pièces J5 à J13. Pour les zones courbes de la coque, découpez les pièces J8 puis collez-les, poncez-les pour leur donner la largeur requise. Confectionnez et fixez les pièces K1 à K8. Rainurez un listeau pour élaborer les pièces L1. Découpez sur mesure les pièces et ajoutez-les à la coque. Continuez à coller les pièces indiquées sur les images. Puis, appliquez du vernis (Réf. 19419) sur toute la coque. Vernissez toutes les pièces en bois que vous ajoutez sur la coque.

M-N. Construisez le balcon à l'aide des pièces M1 à M10. Puis, poncez l'ensemble obtenu. Vérifiez et adaptez l'ensemble à la coque. Recouvrez les points d'unions des pièces avec du mastic (Réf. 19143). Puis, poncez pour égaliser les surfaces. Bordez les toits à l'aide des pièces M11 à M13. Ajustez et collez les pièces M14 à M20. Utilisez une perceuse et des pinces pour tresser deux fils de laiton doubles. Découpez aux dimensions et collez les pièces N1 à N6. Peignez le balcon de couleur noire (Réf. 19196). Puis, poncez les feuilles d'acétate pour leur donner un aspect voilé. Découpez aux dimensions et collez les feuilles d'acétate par l'intérieur du balcon, avec de la colle blanche. Poncez le safran du gouvernail N9 pour lui donner une forme. Ajustez la forme et les dimensions des charnières N10 et fixez-les au gouvernail à l'aide des pointes A, et de la colle rapide. Vous devrez ajuster la longueur des pointes avec des pinces coupantes. Ajustez et fixez le safran du gouvernail sur la coque à l'aide des pointes A.

O-P. Si vous souhaitez peindre la coque du bateau, comme nous vous l'indiquons ci-après, vous devrez la poncer au préalable. Utilisez du papier de verre à grain fin pour poncer toutes les pièces que vous allez peindre. Puis, nettoyez-les pour éliminer la poussière de ponçage. Utilisez du ruban de masquage pour isoler et protéger la zone à ne pas peindre. Appliquez de la peinture de couleur noire (Réf. 19396), sur la partie supérieure de la coque. Peignez la sous-marine de la coque avec de la peinture de couleur blanche (Réf. 19395). Lorsque la peinture sera sèche, appliquez du cirage (Réf. 19417), sur la sous-marine de la coque. Ce produit peut être appliqué directement ou dilué si vous le souhaitez. Vous pouvez aussi l'appliquer directement et ensuite, l'éclaircir au choix avec un chiffon humide. Pour peindre les pièces métalliques, vous devrez d'abord nettoyer les pièces avec de l'alcool et leur appliquer de l'apprêt (Réf. 19418). Peignez les pièces de couleur noire (Réf. 19396), puis appliquez de la peinture de couleur or (Réf. 19408), avec un pinceau sec. Confectionnez et ajoutez au bateau les pièces et ensembles indiqués sur les images. Appliquez du cirage (Réf. 19417) sur les ponts et les cloisons pour obtenir une finition ancienne.

Q-R. Insérez entre elles les pièces Q1 pour construire un caillebotis. Puis découpez-le aux dimensions et confectionnez son cadre. Élaborez et vernissez les pièces indiquées sur les images. Puis appliquez leur le cirage pour homogénéiser la finition avec les ponts. Poursuivez en construisant et en fixant les pièces. Utilisez la base PL-01 pour positionner les pièces sur les ponts. Pour construire le cabestan, vous pouvez utiliser la baguette MT31 pour aligner les pièces.

S. Extrayez les pièces qui formeront la barque et teintez-les de couleur noyer (Réf. 19421). Construisez la charpente de la barque à l'aide des pièces S1 à S10. Ensuite, poncez les couples et les renforts. Bordez la charpente à l'aide des pièces S11. Complétez la barque avec les pièces S12 à S19. Puis vernissez la barque et appliquez-lui du cirage.

T-U. Collez les ancres avec les jas, et décorez les ensembles obtenus. Ajoutez les composants que vous indiquent les images. Confectionnez la claire-voie et décorez-la de couleur noire à l'extérieur et en blanc à l'intérieur. Collez les feuilles d'acétate T10 à l'intérieur des pièces T9. Collez les toits de la claire-voie. Teintez les pièces T12 à T14 avec de la teinte noyer (Réf. 19421), puis construisez l'ensemble. Décorez la plaque avec le nom et collez-la comme le montre l'image. Ajoutez les caps F et G avec le fil U1. Insérez les caps dans les porte-haubans et fixez-les à l'aide des pointes A. Ajoutez les pièces indiquées sur les images.

MÂTURE

La première chose à faire pour confectionner les mâts est de couper les baguettes aux dimensions indiquées dans la liste des pièces ou de prendre ces mesures directement des plans qui sont imprimés à l'échelle 1/1.

Tous les mâts et les vergues possèdent une certaine conicité qui doit être travaillée.

Pour réaliser la conicité des mâts, poncez les baguettes (avec une ponceuse) en augmentant le dégrossissage au fur et à mesure qu'on s'approche de l'extrémité où l'on souhaite diminuer le diamètre. Faire rouler la baguette afin que l'usure soit égale sur tout le contour jusqu'à ce qu'on obtienne le diamètre indiqué sur le plan.

Effectuer les mêmes opérations pour réaliser la conicité des vergues mais, dans ce cas, aux deux extrémités de la baguette.

Il faudra teinter ou peindre les baguettes en fonction de la maquette qui sera construite.

Pour réaliser correctement les mâts de cette maquette, il faudra tenir compte :

- Des plans
- Des photos de détail des mâts.
- Des dimensions et de la description des matériaux de la liste des pièces.
- Des feuilles « IP » d'identification des pièces.
- Le patron PL-01

Les mâts devront être vernis et certaines des pièces qui les composent devront être peintes. Voir les photos générales de détail des mâts.

Lorsque les mâts seront montés et vernis, on placera leurs appareils (estropes, mouffes, pitons, poulies, etc.) et on les attachera au bateau. Les mâts doivent être introduits de sorte qu'ils s'emboîtent à fond contre la fausse quille.

GRÉEMENT

Pour réaliser le gréement de ce bateau, on suivra l'ordre alphabétique des figures imprimées des plans, qui indiquent l'ordre de montage (fils, caps de mouton, poulies, etc.) mis en évidence en rouge. La liste des pièces indique le type de matériaux et les dimensions à utiliser.

Pour simuler le vieillissement des voiles, on peut les faire tremper dans une infusion de thé, sans les faire bouillir, et les laisser sécher bien chiffonnées. Les voiles seront placées non repassées afin d'avoir du volume.

PREPARAZIONE DEL MATERIALE:

Per poter identificare in maniera corretta i pezzi che sono stati ritagliati, prima di estrarli dai blister di legno occorre segnarli con la stessa numerazione che è indicata nella pagina "IP" (Identificazione pezzi) che si trova nelle istruzioni. Lo spessore delle tavole può variare di mezzo millimetro in più o in meno.

INIZIO DEL MONTAGGIO:

Con l'aiuto di un cutter, ed evitando di collocare le dita lungo la linea di taglio, separare i pezzi dai blister eliminando i piccoli nervi che li mantengono attaccati. In seguito, scartavetrare con delicatezza i pezzi, utilizzando una carta vetrata a grana fine, onde eliminare le sbavature degli stess. L'ordine numerico del passo per passo indica l'ordine d'elaborazione e di collocazione dei pezzi. È importante verificare che questi combacino bene, prima d'incollarli definitivamente.

ASTE E BACCHETTE:

I modelli sono dotati di vari tipi di aste e bacchette per formare i diversi pezzi. L'elenco dei pezzi offre informazioni sul tipo di materiale e sulle misure. In alcuni casi è conveniente modificarne le misure quando sono sul modello, man mano che si avanza nel montaggio. In questo modo si potrà ottenere che combacino meglio.

SERVIZIO ASSISTENZA CLIENTE:

Per qualsiasi dubbio o informazione sul montaggio dei nostri prodotti, contattare il nostro Servizio Tecnico al seguente indirizzo:
www.occre.com. Seremo lieti di potervi aiutare.

A. Seguendo l'ordine alfanumerico, inserire e incollare le parti indicate nelle figure. Prima di incollare le coste, verificare che si inseriscano correttamente in posizione "incastrandole" nei corrispondenti alloggiamenti della falsa chiglia. È importante che le coste siano completamente perpendicolari alla falsa chiglia in modo che i ponti si incastrino correttamente. Per questa operazione, utilizzare come collante la colla bianca (colla da falegname, (rif.19200).

B. Tracciare una linea longitudinale che divida il ponte B1 in due metà simmetriche. Iniziare a rivestire adattando la prima striscia alla linea a matita. Utilizzare la colla a contatto (colla per ciabattini) come collante. Con il manico di legno di un utensile, strofinare con forza le lastre contro il ponte in modo che aderiscano saldamente. Posizionare il ponte a faccia in giù e tagliare la lastra in eccesso. Quindi tracciare le linee per simulare il fasciame. Carteggiare il ponte e applicare la vernice satinata (rif.19419). Seguire le stesse procedure per preparare gli altri ponti. Regolare e fissare i ponti come mostrato nelle immagini.

C. Rivestire le paratie con le parti da C1 a C3. Tagliare quindi la lamiera in eccesso. Elaborare e fissare i pezzi da C4 a C10. Applicare la vernice satinata (rif.19419) sulle parti in legno man mano che vengono aggiunte. Montare e incollare le ponti e i rinforzi indicati nelle immagini.

D. Capovolgere lo scafo e iniziare a carteggiare, partendo da prua e procedendo verso poppa. I bordi delle coste devono essere irruviditi, ma senza distorcere la forma originale. Lo scafo deve essere carteggiato in modo simmetrico, cioè il lato destro deve essere uguale a quello sinistro. Anche i rinforzi di prua e di poppa devono essere levigati. La carteggiatura deve essere progressiva e uniforme. Controllare che la levigatura sia corretta con un'asta. A tale scopo, è necessario far scorrere l'asta sulle coste per vedere come si adatta alla loro forma. Immergere i pezzi di D3 in acqua per ripristinare la loro flessibilità e poterli piegare senza romperli. È possibile tingere i pezzi D3 con tintura di noce (cod. 19421), oppure non tingerti e dipingerli di nero in seguito. Applicare la colla e incollare i pezzi D3 su entrambi i lati dello scafo. Fissarli con chiodini A. Per questa operazione si può utilizzare una chiodatrice (rif.19108) o un martello.

E-F. Incollare e fissare i pezzi E1 su entrambi i lati dello scafo. Incollare quindi i pezzi E2 all'interno delle aperture dei pezzi E1. Questi pezzi sono il fondo per il successivo fissaggio dei cannoni della batteria inferiore. Continuare ad aggiungere i pezzi mostrati nelle immagini. Si consiglia di bagnare e curvare i pezzi E4 prima di fissarli definitivamente. È importante applicare la colla sulle parti E4 in modo che siano fissate alla costa e tra loro. Fissare i pezzi E4 con pezzi A. Procedendo con il fasciame dello scafo, tagliare i pezzi nella parte anteriore dello scafo, lasciando uno spazio largo 5 mm. A poppa, tagliarli a filo dello scafo. Realizzare pezzi a misura e incollarli per chiudere gli spazi vuoti nel fasciame dello scafo.

G-H-I. Carteggiare le teste dei chiodini finché non sono a filo con il rivestimento. Quindi carteggiare l'intero scafo. Dovrebbe essere liscio e uniforme.

Utilizzando la colla a contatto (colla per ciabattini) come adesivo, posizionare il rivestimento G1 e G2. Questo secondo rivestimento viene posizionato nello stesso modo del primo. Chiudere le fessure con dei cunei e strofinare con forza le lastre in modo che aderiscano allo scafo. Man mano che si procede con il rivestimento, aprire i fori originali nelle paratie. Assicurarsi che le lastre di rivestimento siano il più vicine possibile per ottenere una buona finitura. Continuare a rivestire lo scafo fino a completarlo. Quindi carteggiare l'intero scafo con carta vetrata a grana fine per ottenere una superficie uniforme. Lavorare e incollare le parti come mostrato nelle immagini. Applicare quindi la vernice (rif.19419).

J-K-L. Con un attrezzo, realizzare le rientranze indicate nella figura su un listello J1. Incollare quindi i listelli J1 su entrambi i lati della barca. Incollare i pezzi J1 a J4. Incollare i pezzi J5 a J13. Per le aree curve dello scafo, tagliare i pezzi J8 e, dopo l'incollaggio, levigarli fino alla larghezza desiderata. Ritagliare e incollare i pezzi da K1 a K8. Incidere un listello per ottenere i pezzi L1. Tagliare i pezzi a misura e aggiungerli allo scafo. Continuare ad aggiungere i pezzi come mostrato nelle immagini. Applicare quindi la vernice (rif.19419) su tutto lo scafo. Verniciare tutte le parti in legno aggiunte allo scafo.

M-N. Costruire la balconata con i pezzi da M1 a M10. Quindi carteggiare l'assemblaggio ottenuto. Controllare e adattare l'assemblaggio allo scafo. Riempire le giunzioni dei pezzi con stucco (rif.19143). Quindi carteggiare per uniformare le superfici. Rivestire i tetti con i pezzi da M11 a M13. Montare e incollare i pezzi da M14 a M20. Con un trapano e una pinza intrecciare due doppi fili di ottone. Tagliare a misura e incollare i pezzi da N1 a N6. Dipingere il balcone di nero (rif.19196). Successivamente, carteggiare gli acetati per renderli velati. Tagliare a misura e incollare gli acetati all'interno della balconata con colla bianca. Carteggiare la pala del timone N9. Regolare la forma e le dimensioni delle cerniere N10 e fissarle al timone con pezzi A e colla rapida. È necessario regolare la lunghezza delle punte con un paio di pinze da taglio. Montare e fissare la pala del timone allo scafo utilizzando i pezzi A.

O-P. Se si desidera verniciare lo scafo della barca come illustrato di seguito, è necessario prima carteggiare lo scafo. Utilizzare carta vetrata a grana fine per carteggiare tutte le parti da verniciare. Pulire quindi lo scafo rimuovendo la polvere prodotta dalla carteggiatura. Utilizzare del nastro adesivo per isolare e proteggere l'area che non si desidera verniciare. Applicare la vernice nera (rif.19396) sulla parte superiore dello scafo. Dipingere di bianco la parte inferiore dello scafo (rif.19395). Quando la vernice si è asciugata, applicare il bitume di Giudea (rif.19417) sulla parte inferiore dello scafo. Questo prodotto può essere applicato direttamente o diluito, se lo si desidera. Oppure si può applicare direttamente e poi, se si vuole, con un panno umido si può risciacquare. Per verniciare le parti metalliche, è necessario prima pulirle con alcool e applicare il primer (rif.19418). Dipingere le parti di nero (rif.19396) e poi applicare la vernice dorata (cod. 19408) con un pennello asciutto. Costruire e aggiungere alla barca le parti e gli assemblaggi indicati nelle immagini. Applicare il bitume di Giudea (rif.19417) sui ponti e sulle paratie per ottenere una finitura invecchiata.

Q-R. Inserire i pezzi Q1 l'uno nell'altro per creare un carabottino. Quindi tagliare a misura e realizzare il carabottino. Lavorare e verniciare i pezzi mostrati nelle immagini. Quindi, applicare il bitume di Giudea per abbinare la finitura ai ponti. Continuare a costruire e attaccare i pezzi. Utilizzare la dima PL-01 per posizionare i pezzi sui ponti. Per costruire l'argano si può usare l'asta MT31 per allineare i pezzi.

S. Rimuovere i pezzi che formeranno la barca e tingerti con un colorante color noce (rif.19421). Costruire lo scheletro della barca con i pezzi da S1 a S10. Quindi carteggiare le cornici e i rinforzi. Rivestire lo scheletro con i pezzi S11. Completare la barca con i pezzi da S12 a S19. Quindi verniciare la barca e applicare il bitume di Giudea.

T-U. Incollare gli ancoraggi con le scorte e decorare gli assemblaggi ottenuti. Aggiungere i componenti indicati nelle immagini. Costruire la persiana e decorarla in nero all'esterno e in bianco all'interno. Incollare gli acetati T10 all'interno dei pezzi T9. Incollare i tetti della persiana. Colorare i pezzi da T12 a T14 con il colore noce (cod. 19421), quindi costruire l'insieme. Decorare la scritta del nome e incollarla come mostrato nell'immagine. Annodare le bigotte F e G con il filo U1. Inserire le travi attraverso le tavole di guarnizione e fissarle con i chiodini A. Aggiungere i pezzi come mostrato nelle immagini.

ALBERATURA

Per realizzare l'alberatura, il primo passo da seguire sarà quello di tagliare le aste secondo le misure indicate nell'elenco dei pezzi, oppure prenderle direttamente dalle planimetrie che sono stampate in scala 1/1.

Tutti gli alberi e i pennoni hanno una certa conicità che si dovrà ottenere.

Per ottenere la conicità degli alberi, occorre scartavetrare le aste (con una smerigliatrice), aumentando l'azione della stessa a misura che ci si avvicina all'estremità dove si deve diminuire il diametro. Far girare l'asta affinché la smerigliatura sia uguale su tutto il contorno, fino ad arrivare al diametro indicato nella planimetria.

Per ottenere la conicità dei pennoni, realizzare le stesse operazioni, ma in questo caso su entrambe le estremità dell'asta. Si dovranno verniciare o tingere le aste in funzione del modello che si stia realizzando.

Per realizzare gli alberi di questo modello in maniera corretta si dovranno utilizzare:

- Le planimetrie;
- Le foto dettagliate degli alberi;
- Le misure e la descrizione dei materiali nell'elenco dei pezzi;
- Le pagine "IP" con l'identificazione dei pezzi.
- La sagoma PL-01

Gli alberi devono essere smaltati ed alcuni dei pezzi che li compongono devono essere verniciati. Vedi le foto generali dettagliate degli alberi.

Una volta montati e smaltati, devono essere collocati gli attrezzi (stropi, quarnali, golfare, bozzelli, ecc.) e fissati al vascello.

Gli alberi devono essere introdotti fino in fondo negli appositi incastri della falsa chiglia.

SARTIA

Per elaborare la sartia di questo vascello occorre seguire l'ordine alfabetico delle figure stampate delle planimetrie, che indicano l'ordine di collocazione delle cime, delle bigotte, dei bozzelli, delle vele, ecc., risaltati in colore rosso. L'elenco dei pezzi serve ad orientare in merito al tipo di materiali ed alle misure da utilizzare.

Per simulare l'invecchiamento delle vele, queste possono essere bagnate con te, senza farle bollire, e poi lasciarle asciugare mantenendole ben arrugate.

Poi si collocano senza stirarle, affinché mantengano corpo.

VORBEREITUNG DER MATERIALIEN:

Damit die einzelnen Bauteile korrekt zugeordnet werden können, empfehlen wir, auf den Holzplättchenvor dem Herausnehmen mit einem Bleistift die Nummer auf dem Blatt IP (Identifikation Teile) zu markieren. Die Dicke der Bretter kann um mehr oder weniger einen halben Millimeter variieren.

BEGINN DES ZUSAMMENBAUS:

Die Teile mit einem Schneidewerkzeug (Cutter) herauslösen und die kleinen Befestigungsenden entfernen. Dabei darauf achten, die Finger nicht zu verletzen. Danach die Teile vorsichtig mit feinem Schmirgelpapier säubern, um ausgefranste Ränder zu entfernen. Die Nummernfolge der Schritte auf Fotos und Skizzen gibt an, in welcher Reihenfolge die Teile zusammengebaut werden.

LEISTEN UND STÄBE:

Die Modelle enthalten mehrere Arten von Leisten und Stäben, aus denen die einzelnen Teile des Bausatzes geformt werden. In einigen Fällen kann es angebracht sein, die Maße im Zuge des Zusammenbaus entsprechend dem Modell anzupassen. Auf diese Weise wird eine bessere Passform errichtet.

UNSER KUNDENDIENST:

Bei Fragen zum Aufbau unserer Modelle steht Ihnen unser Kundendienst zur Verfügung. Sie erreichen uns online unter: www.occre.com. Wir stehen Ihnen gern mit Rat und Tipps zur Verfügung.

A. Die auf den Abbildungen gezeigten Teile in der angegebenen Reihenfolge einsetzen und aufkleben. Vor dem Aufkleben der Spanten sicherstellen, dass die sie korrekt sitzen und mit den dazugehörigen Einkerbungen des falschen Kiels abschließen. Die Spanten müssen vollkommen senkrecht auf dem falschen Kiel stehen, damit danach die Decks gut eingesetzt werden können. Für diese Schritte weißen Kleber (Tischlerleim, Ref. 19200) verwenden.

B. Eine Längslinie ziehen, mit der das Deck B1 in zwei symmetrische Hälften geteilt wird. Dabei die erste Plankenreihe an der Bleistiftlinie ausrichten. Zum Kleben Kontaktkleber verwenden (Schusterleim). Mit dem Holzstiel eines Werkzeugs das Furnier kräftig auf das Deck reiben, bis es fest haftet. Das Deck mit der Oberseite nach unten aufsetzen und die überstehenden Teile der Leisten abschneiden. Abschließend Linien ziehen und Markierungen anbringen, um die Schiffsbeplankung zu simulieren. Das Deck glatt schmirgeln und Satinlack auftragen (Ref. 19419). Bei der Vorbereitung der anderen Decks ebenso verfahren. Die Decks wie auf den Abbildungen gezeigt anpassen und befestigen.

C. Die Schotts mit den Teilen C1 bis C3 verkleiden. Anschließend die überstehenden Enden der Leisten abschneiden. Die Teile C4 bis C10 anfertigen und befestigen. Satinlack (Ref. 19419) auf die Holzstücke auftragen, die hinzugefügt werden. Die auf den Abbildungen gezeigten Decks und Verstrebungen anpassen und aufkleben.

D. Den Rumpf mit der Oberseite nach unten anbringen und vom Bug in Richtung Heck glatt schleifen. Die Kanten der Spanten glätten, aber dabei nicht das ursprüngliche Profil verändern. Beim Glätten des Rumpfs darauf achten, dass beide Seiten symmetrisch zueinander sein müssen. Die Verstrebungen am Bug und Heck ebenfalls glattschmirgeln. Die Oberfläche nach und nach vorsichtig glätten. Mit der Leiste testen, ob eine gleichmäßige Oberfläche hergestellt wurde. Dazu die Leiste über die Spanten fahren und prüfen, wie sie sich der Form anpasst. Die Leisten D3 in Wasser einweichen, damit sie biegsamer werden und nicht brechen. Die Teile D3 mit Nussbaumfarbe (Ref.19421) lackieren oder unlackiert lassen und später schwarz anmalen. Auf die Teile D3 Leim auftragen und sie an beiden Seiten des Rumpfs aufkleben. Mit den Stiften A befestigen. Dazu kann man einen Nagler (Ref.19108) oder einen Hammer verwenden.

E-F. Die Teile E1 zurechtschneiden und an beiden Seiten des Rumpfs befestigen. Anschließend die Teile E2 auf die Innenseite der Öffnungen der Teile E1 kleben. Diese Teile sind die Böden, auf denen später die Kanonen der unteren Geschützbatterie angebracht werden. Die Teile, die auf den Abbildungen zu sehen sind, hinzufügen. Es ist ratsam, die Teile E4 vor der endgültigen Befestigung zu befeuchten und zu biegen. Es ist wichtig, die Teile E4 mit Klebstoff zu bestreichen, um sie an den Spanten und untereinander befestigen zu können. Die Teile E4 mit Stiften A festmachen. Beim Auskleiden des Rumpfs die Teile an der Vorderseite des Rumpfs abschneiden, so dass ein 5 mm breiter Spalt entsteht. Am hinteren Ende die Teile bündig zum Rumpf abschneiden. Individuelle Teile nach Maß zurechtschneiden und zusammenkleben, um die Löcher in der Rumpfverkleidung zu schließen.

G-H-I. Die Stiftpföpfe glattfeilen, bis sie auf einer Höhe mit den Plankenreihen sind. Anschließend den gesamten Rumpf glatt schmirgeln. Es muss eine glatte und gleichmäßige Oberfläche entstehen.

Kontaktkleber (Schusterleim) verwenden, die Beplankung G1 und G2 aufsetzen. Diese zweite Beplankung wird auf die gleiche Weise wie die erste angebracht. Die Zwischenräume mit Schlusskeilen abschließen und die Leisten fest andrücken, damit sie am Rumpf anhaften. Die Planken, die die Öffnungen der Schanzverkleidung verdecken, während des Wegerns nach und nach öffnen. Für ein gleichmäßiges Finish darauf achten, dass die Plankenreihen so nah wie möglich nebeneinander sitzen. Den Schiffsrumpf vollständig mit Planken versehen. Anschließend die Teile vorsichtig mit feinem Schmirgelpapier bearbeiten, so dass eine gleichmäßige Oberfläche entsteht. Die Teile, die auf den Abbildungen zu sehen sind, anfertigen, lackieren und ankleben. Anschließend Lack auftragen (Ref.19419).

J-K-L. Mit einem Werkzeug die auf der Abbildung gezeigten Aussparungen an einer Leiste J1 anbringen. Anschließend die Leisten J1 auf beiden Schiffsseiten aufkleben. Die Teile J1 bis J4 zurechtschneiden und aufkleben. Die Teile J5 bis J13 anfertigen und aufkleben. Für die gebogenen Bereiche des Rumpfs die Teile J8 zurechtschneiden und nach dem Zusammenkleben auf die gewünschte Breite zurechtfeilen. Die Teile K1 bis K8 anfertigen und befestigen. Eine Leiste mit einem Schlitz versehen, um die Teile L1 anzufertigen. Die Teile nach Maß zurechtschneiden und am Rumpf anbringen. Die Teile, die auf den Abbildungen zu sehen sind, hinzufügen. Anschließend Lack (Ref.19419) auf den gesamten Rumpf auftragen. Alle Holzteile, die am Rumpf angebracht werden müssen, lackieren.

M-N. Den Heckbalkon aus den Teilen M1 bis M10 anfertigen. Anschließend die entstandene Baugruppe glatt schmirgeln. Die Baugruppe überprüfen und an den Rumpf anpassen. Die Fugen der Teile mit Fugen Kitt (Ref. 19143) abdecken. Anschließend glatt schmirgeln, um eine gleichmäßige Oberfläche herzustellen. Die Dächer mit den Teilen M11 bis M13 verkleiden. Die Teile M14 bis M20 zurechtschneiden und aufkleben. Mithilfe einer Bohrmaschine und einer Zange zwei doppelte Messingdrähte flechten. Die Teile N1 bis N6 zurechtschneiden und aufkleben. Den Heckbalkon schwarz (Ref.19196) anmalen. Anschließend die Fensterfolien abschleifen, um ihnen Patina zu verleihen. Die Fensterfolien zurechtschneiden und mit weißem Leim an die Innenseite der Fenster kleben. Das Steuerblatt N9 glatt schmirgeln und in die passende Form bringen. Die Scharniere N10 in die passende Form und Größe bringen und mit Stiften A und Sekundenkleber am Steuer befestigen. Die Stifte mit einer Zange auf die erforderlichen Längen zurechtschneiden. Das Steuerblatt am Rumpf anpassen und mit den Stiften A befestigen.

O-P. Vor dem Lackieren des Rumpfs in der unten beschriebenen Form den Rumpf zunächst glatt schmirgeln. Dazu feines Schleifpapier verwenden und alle zu lackierenden Teile abschleifen. Anschließend den dabei entstandenen Staub entfernen. Kreppband verwenden, um die Bereiche, die nicht lackiert werden sollen, abzudecken. Schwarze Farbe (Ref.19396) auf die Oberseite des Rumpfs auftragen. Die Unterseite des Rumpfs in weiß (Ref.19395) lackieren. Wenn die Farbe getrocknet ist, Asphaltfarbe (Ref. 19417) auf die Unterseite des Rumpfs auftragen. Dieses Produkt kann direkt oder falls gewünscht verdünnt aufgetragen werden. Sie können die Farbe auch direkt auftragen und anschließend mit einem feuchten Tuch abwaschen. Um Metallteile zu lackieren, die Teile zunächst mit Alkohol reinigen und mit Grundierung (Ref. 19418) behandeln. Die Teile schwarz (Ref. 19396) anmalen und anschließend mit einem trockenen Pinsel goldene Farbe (Ref. 19408) auftragen. Die auf den Abbildungen gezeigten Teile und Baugruppen anfertigen und auf dem Schiffsmodell anbringen. Asphaltfarbe (Ref. 19417) auf Decks und Schotts auftragen, um dem Modell eine verwitterte Optik zu verleihen.

Q-R. Die Teile Q1 ineinander stecken, um eine Grating anzufertigen. Anschließend zurechtschneiden und den Rahmen anfertigen. Die Teile, die auf den Abbildungen zu sehen sind, anfertigen und lackieren. Dann Asphaltfarbe auftragen, um die Teile an die Dächer anzupassen. Die gezeigten Teile anfertigen und befestigen. Die die Schablone PL-01 verwenden, um die Teile auf den Decks zu platzieren. Zum Bau des Spills den Stab MT31 zum Ausrichten der Teile verwenden.

S. Die Teile, aus denen das Boot gebaut wird, mit Walnusstinte (Ref. 19421) lackieren. Das Skelett des Beiboots aus den Teilen S1 bis S10 anfertigen. Anschließend Rahmen und Verstärkungen glatt schmirgeln. Das Bootskelett mit den S11-Teilen verkleiden. Das Boot mit den Teilen S12 bis S19 fertigstellen. Anschließend lackieren und Asphaltfarbe auftragen.

T-U. Die Ankerstöcke an die Anker kleben und die so erhaltenen Baugruppen verzieren. Die Komponenten, die auf den Abbildungen zu sehen sind, hinzufügen. Das Oberlicht anfertigen und außen schwarz und innen weiß anmalen. Die Folie T10 auf die Innenseite der Teile T9 kleben. Dächer des Oberlichts aufkleben. Die Teile T12 bis T14 mit Walnusstinte (Ref. 19421) anmalen und anschließend die Baugruppe zusammenbauen. Das Namensschild verzieren und wie auf der Abbildung gezeigt ankleben. Die Klampböcke F und G mit dem Faden U1 verknoten. Die Klampböcke durch die Rüste ziehen und mit den Stiften A befestigen. Die Teile, die auf den Abbildungen zu sehen sind, hinzufügen.

BEMASTUNG

Zur Herstellung der Masten müssen zuerst die Stäbe entsprechend der Maße zurecht geschnitten werden, die in der Teilleiste angegeben sind oder die direkt anhand der Skizze abgemessen wurde. Die Skizzen sind im Maßstab 1/1 angefertigt.

Alle Masten und Rahen müssen leicht konisch verlaufen und vor dem Einbau entsprechen vorbereitet werden.

Um die Masten in Konusform zu bringen, müssen die Masten (mit einer Feile) zurecht geschliffen werden, und zwar in der Form, dass sie nach oben hin verjüngt werden. Die Stäbe dabei drehen und an allen Seiten gleichmäßig abschleifen, bis sie zu dem auf der Skizze angegebenen Durchmesser passen.

Um die Rahen in Konusform zu bringen, ebenso verfahren, allerdings hier an beiden Enden der Stangen.

Die Stäbe in Abhängigkeit vom Modell färben oder anmalen.

Um die Masten dieses Schiffsbaumodells richtig vorzubereiten, müssen die folgenden Punkte beachtet werden:

-Die Skizzen - Detailfotos der Masten - Maße und Materialien der Teilleiste - IP-Blätter zur Identifikation der Bauteile - Schablone PL-01

Die Masten müssen lackiert werden und einige der Einzelteile der Masten müssen angemalt werden. Siehe Fotos mit allgemeiner Ansicht der Masten

Nach Aufstellung und Lackierung der Masten wird die Takelung (Stroppe, Rollenblöcke, Ösen, Blockrollen etc.) an den Masten und dann am Schiff befestigt. Die Masten müssen eingesetzt werden, bis sie an die Einkerbungen des falschen Kiels stoßen.

TAKELAGE

Zur Takelung des Schiffsmodells die alphabetische Reihenfolge der Abbildungen befolgen, auf denen die Anbringung der Takelung (Faden, Klampböcke, Blockrollen usw.) erläutert wird. Sie sind in Rot hervorgehoben. Auf der Teilleiste sehen Sie, welche Materialien zum Bau des Modells notwendig sind.

Zur künstlichen Alterung der Segel die Stoffstücke in Tee legen (nicht kochen) und trocknen lassen, bis die Stoffe faltig werden.

Die Segel ohne vorheriges Bügeln anbringen, damit sie Volumen haben.

OCCRE

CISNE NEGRO

Ref.12012

2

Listas de piezas
Parts lists
Liste de pièces
Elenchi dei pezzi
Liste der teile



Lista de piezas / Parts List / Liste des pièces / Teilleiste / Elenco delle parti

N°/No./N° / Nr. No	Cantidad / Quantity / Quantité / Menge / Quantità	Medidas / Measurements / Dimensions /Maße / Misure	Material / Material / Matériau / Material / Materiale
A1	1	Precortado / Precut / Prédécoupé / Vorgeschnitten / Pretagliatto	Tablero / Plywood / Planche / Sperrholz / Tavola
A2-A10	9	Precortado / Precut / Prédécoupé / Vorgeschnitten / Pretagliatto	Tablero / Plywood / Planche / Sperrholz / Tavola
A11-A12	3	Precortado / Precut / Prédécoupé / Vorgeschnitten / Pretagliatto	Tablero / Plywood / Planche / Sperrholz / Tavola
A13-A14	4	Precortado / Precut / Prédécoupé / Vorgeschnitten / Pretagliatto	Tablero / Plywood / Planche / Sperrholz / Tavola
A15-A16	4	Precortado / Precut / Prédécoupé / Vorgeschnitten / Pretagliatto	Tablero / Plywood / Planche / Sperrholz / Tavola
B1	1	Precortado / Precut / Prédécoupé / Vorgeschnitten / Pretagliatto	Tablero / Plywood / Planche / Sperrholz / Tavola
B2	120	0,6x5x50	Sicomoro / Sycamore / Sycomore / Bergahorn / Sicomoro
B3	1	Precortado / Precut / Prédécoupé / Vorgeschnitten / Pretagliatto	Tablero / Plywood / Planche / Sperrholz / Tavola
B4	36	0,6x5x50	Sicomoro / Sycamore / Sycomore / Bergahorn / Sicomoro
B5	1	Precortado / Precut / Prédécoupé / Vorgeschnitten / Pretagliatto	Tablero / Plywood / Planche / Sperrholz / Tavola
B6	52	0,6x5x50	Sicomoro / Sycamore / Sycomore / Bergahorn / Sicomoro
B7	1	Precortado / Precut / Prédécoupé / Vorgeschnitten / Pretagliatto	Tablero / Plywood / Planche / Sperrholz / Tavola
B8	17	0,6x5x50	Sicomoro / Sycamore / Sycomore / Bergahorn / Sicomoro
B9	1	Precortado / Precut / Prédécoupé / Vorgeschnitten / Pretagliatto	Tablero / Plywood / Planche / Sperrholz / Tavola
B10	6	0,6x5x50	Sicomoro / Sycamore / Sycomore / Bergahorn / Sicomoro
B11	1	Precortado / Precut / Prédécoupé / Vorgeschnitten / Pretagliatto	Tablero / Plywood / Planche / Sperrholz / Tavola
B12	10	0,6x5x50	Sicomoro / Sycamore / Sycomore / Bergahorn / Sicomoro
B13	1	Precortado / Precut / Prédécoupé / Vorgeschnitten / Pretagliatto	Tablero / Plywood / Planche / Sperrholz / Tavola
C1	9	0,6x5x100	Sicomoro / Sycamore / Sycomore / Bergahorn / Sicomoro
C2	5	0,6x5x85	Sicomoro / Sycamore / Sycomore / Bergahorn / Sicomoro
C3	3	0,6x5x110	Sicomoro / Sycamore / Sycomore / Bergahorn / Sicomoro
C4	1	1x3x69	Tilo / Lime wood / Tilleul / Linde / Tiglio
C5	5	1x3x37	Tilo / Lime wood / Tilleul / Linde / Tiglio
C6	6	1x3x15	Tilo / Lime wood / Tilleul / Linde / Tiglio
C7	1	1x3x65	Tilo / Lime wood / Tilleul / Linde / Tiglio
C8	4	1x3x20	Tilo / Lime wood / Tilleul / Linde / Tiglio
C9	1	1x3x92	Tilo / Lime wood / Tilleul / Linde / Tiglio
C10	4	1x3x16	Tilo / Lime wood / Tilleul / Linde / Tiglio
C11-C12	4	Precortado / Precut / Prédécoupé / Vorgeschnitten / Pretagliatto	Tablero / Plywood / Planche / Sperrholz / Tavola
C13-C14	4	Precortado / Precut / Prédécoupé / Vorgeschnitten / Pretagliatto	Tablero / Plywood / Planche / Sperrholz / Tavola
C15	2	Precortado / Precut / Prédécoupé / Vorgeschnitten / Pretagliatto	Tablero / Plywood / Planche / Sperrholz / Tavola
C16	2	Precortado / Precut / Prédécoupé / Vorgeschnitten / Pretagliatto	Tablero / Plywood / Planche / Sperrholz / Tavola
C17	1	Precortado / Precut / Prédécoupé / Vorgeschnitten / Pretagliatto	Tablero / Plywood / Planche / Sperrholz / Tavola
C18	4	Precortado / Precut / Prédécoupé / Vorgeschnitten / Pretagliatto	Tablero / Plywood / Planche / Sperrholz / Tavola
D1	6	0,6x5x50	Sicomoro / Sycamore / Sycomore / Bergahorn / Sicomoro
D2	1	2x5x600	Tilo / Lime wood / Tilleul / Linde / Tiglio
D3	2	Precortado / Precut / Prédécoupé / Vorgeschnitten / Pretagliatto	Tablero / Plywood / Planche / Sperrholz / Tavola
E1	2	Precortado / Precut / Prédécoupé / Vorgeschnitten / Pretagliatto	Tablero / Plywood / Planche / Sperrholz / Tavola
E2	24	Precortado / Precut / Prédécoupé / Vorgeschnitten / Pretagliatto	Tablero / Plywood / Planche / Sperrholz / Tavola
E3	10	2x5x90	Tilo / Lime wood / Tilleul / Linde / Tiglio
E4	2	2x5x600	Tilo / Lime wood / Tilleul / Linde / Tiglio
F1	40	2x5x600	Tilo / Lime wood / Tilleul / Linde / Tiglio
G1	18	0,6x5x90	Sapelly / Sapelli / Sapelli / Sapelly-Holz / Sapelli
G2	2	0,6x5x600	Sapelly / Sapelli / Sapelli / Sapelly-Holz / Sapelli

Lista de piezas / Parts List / Liste des pièces / Teilleiste / Elenco delle parti

Nº/No./Nº / Nr. No	Cantidad / Quantity / Quantité / Menge / Quantità	Medidas / Measurements / Dimensions /Maße / Misure	Material / Material / Matériau / Material / Materiale
H1	40	0,6x5x600	Sapelly / Sapelli / Sapelli / Sapelly-Holz / Sapelli
i1	6	0,6x5x600	Sapelly / Sapelli / Sapelli / Sapelly-Holz / Sapelli
i2	1	Precortado / Precut / Prédécoupé / Vorgeschnitten / Pretagliatto	Nogal africano / African walnut / Noyer africain / Afrikanisches Nußbaumholz / Noce africano
i3	1	Precortado / Precut / Prédécoupé / Vorgeschnitten / Pretagliatto	Nogal africano / African walnut / Noyer africain / Afrikanisches Nußbaumholz / Noce africano
i4-i5	2	Precortado / Precut / Prédécoupé / Vorgeschnitten / Pretagliatto	Nogal africano / African walnut / Noyer africain / Afrikanisches Nußbaumholz / Noce africano
i6	1	Precortado / Precut / Prédécoupé / Vorgeschnitten / Pretagliatto	Nogal africano / African walnut / Noyer africain / Afrikanisches Nußbaumholz / Noce africano
i7	1	Precortado / Precut / Prédécoupé / Vorgeschnitten / Pretagliatto	Nogal africano / African walnut / Noyer africain / Afrikanisches Nußbaumholz / Noce africano
J1	2	2x2x600	Tilo / Lime wood / Tilleul / Linde / Tiglio
J2	4	1x5x400	Tilo / Lime wood / Tilleul / Linde / Tiglio
J3	2	2x2x600	Tilo / Lime wood / Tilleul / Linde / Tiglio
J4	2	2x2x600	Tilo / Lime wood / Tilleul / Linde / Tiglio
J5	20	1x3x15	Tilo / Lime wood / Tilleul / Linde / Tiglio
J6	2	1x3x45	Tilo / Lime wood / Tilleul / Linde / Tiglio
J7	2	2x6x150	Tilo / Lime wood / Tilleul / Linde / Tiglio
J8	34	2x2x6	Tilo / Lime wood / Tilleul / Linde / Tiglio
J9	2	2x6x70	Tilo / Lime wood / Tilleul / Linde / Tiglio
J10	1	2x6x59	Tilo / Lime wood / Tilleul / Linde / Tiglio
J11	2	2x6x60	Tilo / Lime wood / Tilleul / Linde / Tiglio
J12	2	2x6x54	Tilo / Lime wood / Tilleul / Linde / Tiglio
J13	2	2x6x18	Tilo / Lime wood / Tilleul / Linde / Tiglio
K1	55	2x2x5	Tilo / Lime wood / Tilleul / Linde / Tiglio
K2	2	1x3x70	Tilo / Lime wood / Tilleul / Linde / Tiglio
K3	1	1x3x67	Tilo / Lime wood / Tilleul / Linde / Tiglio
K4	2	1x3x188	Tilo / Lime wood / Tilleul / Linde / Tiglio
K5	2	1x3x65	Tilo / Lime wood / Tilleul / Linde / Tiglio
K6	4	2x2x12	Tilo / Lime wood / Tilleul / Linde / Tiglio
K7	4	2x2x32	Tilo / Lime wood / Tilleul / Linde / Tiglio
K8	4	2x2x46	Tilo / Lime wood / Tilleul / Linde / Tiglio
L1	20	2x2x10	Tilo / Lime wood / Tilleul / Linde / Tiglio
L2-L4	3	Precortado / Precut / Prédécoupé / Vorgeschnitten / Pretagliatto	Tablero / Plywood / Planche / Sperrholz / Tavola
L5	4	Precortado / Precut / Prédécoupé / Vorgeschnitten / Pretagliatto	Tablero / Plywood / Planche / Sperrholz / Tavola
L6	4	2x2x70	Tilo / Lime wood / Tilleul / Linde / Tiglio
L7	2	Preformado / Preformed/ Préformé / Vorgeformt / Preformato	Latón / Brass / Latón / Messing / Ottone
L8	2	2x6x12	Tilo / Lime wood / Tilleul / Linde / Tiglio
L9-L10	4	Precortado / Precut / Prédécoupé / Vorgeschnitten / Pretagliatto	Tablero / Plywood / Planche / Sperrholz / Tavola
L11	3	1x3x28	Tilo / Lime wood / Tilleul / Linde / Tiglio
L12	2	1x3x42	Tilo / Lime wood / Tilleul / Linde / Tiglio
L13	1	1x3x64	Tilo / Lime wood / Tilleul / Linde / Tiglio
L14	12	1x3x15	Tilo / Lime wood / Tilleul / Linde / Tiglio
L15	1	Preformado / Preformed/ Préformé / Vorgeformt / Preformato	Madera / Wood / Bois / Holz / Legno
L16-L17	3	Precortado / Precut / Prédécoupé / Vorgeschnitten / Pretagliatto	Tablero / Plywood / Planche / Sperrholz / Tavola
M1	1	Precortado / Precut / Prédécoupé / Vorgeschnitten / Pretagliatto	Tablero / Plywood / Planche / Sperrholz / Tavola
M2	1	Precortado / Precut / Prédécoupé / Vorgeschnitten / Pretagliatto	Tablero / Plywood / Planche / Sperrholz / Tavola
M3	2	Precortado / Precut / Prédécoupé / Vorgeschnitten / Pretagliatto	Tablero / Plywood / Planche / Sperrholz / Tavola

Lista de piezas / Parts List / Liste des pièces / Teilleiste / Elenco delle parti

N°/No./N° / Nr. No	Cantidad / Quantity / Quantité / Menge / Quantità	Medidas / Measurements / Dimensions /Maße / Misure	Material / Material / Matériau / Material / Materiale
M4	1	Precortado / Precut / Prédécoupé / Vorgeschnitten / Pretagliatto	Tablero / Plywood / Planche / Sperrholz / Tavola
M5	2	Precortado / Precut / Prédécoupé / Vorgeschnitten / Pretagliatto	Tablero / Plywood / Planche / Sperrholz / Tavola
M6	2	Precortado / Precut / Prédécoupé / Vorgeschnitten / Pretagliatto	Tablero / Plywood / Planche / Sperrholz / Tavola
M7-M10	8	Precortado / Precut / Prédécoupé / Vorgeschnitten / Pretagliatto	Tablero / Plywood / Planche / Sperrholz / Tavola
M11	5	1x3x80	Tilo / Lime wood / Tilleul / Linde / Tiglio
M12	10	1x3x56	Tilo / Lime wood / Tilleul / Linde / Tiglio
M13	10	4x4x13	Tilo / Lime wood / Tilleul / Linde / Tiglio
M14	2	Preformado / Preformed/ Préformé / Vorgeformt / Preformato	Latón / Brass / Latón / Messing / Ottone
M15	1	Preformado / Preformed/ Préformé / Vorgeformt / Preformato	Latón / Brass / Latón / Messing / Ottone
M16	2	Preformado / Preformed/ Préformé / Vorgeformt / Preformato	Latón / Brass / Latón / Messing / Ottone
M17	1	Preformado / Preformed/ Préformé / Vorgeformt / Preformato	Latón / Brass / Latón / Messing / Ottone
M18	1	Preformado / Preformed/ Préformé / Vorgeformt / Preformato	Latón / Brass / Latón / Messing / Ottone
M19	2	Preformado / Preformed/ Préformé / Vorgeformt / Preformato	Latón / Brass / Latón / Messing / Ottone
M20	1	Preformado / Preformed/ Préformé / Vorgeformt / Preformato	Latón / Brass / Latón / Messing / Ottone
N1	12	ø0,50x34	Latón / Brass / Latón / Messing / Ottone
N2	4	ø0,50x20	Latón / Brass / Latón / Messing / Ottone
N3	2	ø0,50x62	Latón / Brass / Latón / Messing / Ottone
N4	1	ø0,50x85	Latón / Brass / Latón / Messing / Ottone
N5	2	ø0,50x14	Latón / Brass / Latón / Messing / Ottone
N6	2	0,6x5x27	Sicomoro / Sycamore / Sycomore / Bergahorn / Sicomoro
N7-N8	3	Preformado / Preformed/ Préformé / Vorgeformt / Preformato	Acetato / Acetate / Acétate / Acetat / Acetato
N9	1	Precortado / Precut / Prédécoupé / Vorgeschnitten / Pretagliatto	Nogal africano / African walnut / Noyer africain / Afrikanisches Nußbaumholz / Noce africano
N10	8	Preformado / Preformed/ Préformé / Vorgeformt / Preformato	Latón / Brass / Latón / Messing / Ottone
N11	4	ø1,5x6	Latón / Brass / Latón / Messing / Ottone
o1	2	Preformado / Preformed/ Préformé / Vorgeformt / Preformato	Tablero / Plywood / Planche / Sperrholz / Tavola
o2	2	Preformado / Preformed/ Préformé / Vorgeformt / Preformato	Tablero / Plywood / Planche / Sperrholz / Tavola
o3	2	Preformado / Preformed/ Préformé / Vorgeformt / Preformato	Tablero / Plywood / Planche / Sperrholz / Tavola
o4	2	Preformado / Preformed/ Préformé / Vorgeformt / Preformato	Tablero / Plywood / Planche / Sperrholz / Tavola
o5	2	2x2x15	Tilo / Lime wood / Tilleul / Linde / Tiglio
o6	2	2x2x25	Tilo / Lime wood / Tilleul / Linde / Tiglio
o7	2	2x2x59	Tilo / Lime wood / Tilleul / Linde / Tiglio
o8	2	2x2x70	Tilo / Lime wood / Tilleul / Linde / Tiglio
o9	1	Preformado / Preformed/ Préformé / Vorgeformt / Preformato	Metal / Metal / Metal / Metall / Metallo
o10-o11	2	Preformado / Preformed/ Préformé / Vorgeformt / Preformato	Metal / Metal / Metal / Metall / Metallo
o12	3	Preformado / Preformed/ Préformé / Vorgeformt / Preformato	Metal / Metal / Metal / Metall / Metallo
o13	3	ø1,5x10	Latón / Brass / Latón / Messing / Ottone
o14	4	Preformado / Preformed/ Préformé / Vorgeformt / Preformato	Metal / Metal / Metal / Metall / Metallo
o15	12	Preformado / Preformed/ Préformé / Vorgeformt / Preformato	Metal / Metal / Metal / Metall / Metallo
o16	1	Preformado / Preformed/ Préformé / Vorgeformt / Preformato	Metal / Metal / Metal / Metall / Metallo
o17	1	Preformado / Preformed/ Préformé / Vorgeformt / Preformato	Metal / Metal / Metal / Metall / Metallo
o18	1	Preformado / Preformed/ Préformé / Vorgeformt / Preformato	Metal / Metal / Metal / Metall / Metallo
P1	1	2x2x75	Tilo / Lime wood / Tilleul / Linde / Tiglio
P2	24	Precortado / Precut / Prédécoupé / Vorgeschnitten / Pretagliatto	Tablero / Plywood / Planche / Sperrholz / Tavola
P3	24	Precortado / Precut / Prédécoupé / Vorgeschnitten / Pretagliatto	Tablero / Plywood / Planche / Sperrholz / Tavola



Lista de piezas / Parts List / Liste des pièces / Teilleiste / Elenco delle parti

N°/No./N° / Nr. No	Cantidad / Quantity / Quantité / Menge / Quantità	Medidas / Measurements / Dimensions /Maße / Misure	Material / Material / Matériau / Material / Materiale
P4	48	Preformado / Preformed/ Préformé / Vorgeformt / Preformato	Latón / Brass / Latón / Messing / Ottone
P5	1	Preformado / Preformed/ Préformé / Vorgeformt / Preformato	Metal / Metal / Metal / Metall / Metallo
P6	2	Preformado / Preformed/ Préformé / Vorgeformt / Preformato	Metal / Metal / Metal / Metall / Metallo
P7	2	Preformado / Preformed/ Préformé / Vorgeformt / Preformato	Metal / Metal / Metal / Metall / Metallo
P8	1	Preformado / Preformed/ Préformé / Vorgeformt / Preformato	Madera / Wood / Bois / Holz / Legno
P9	2	2x3x17	Tilo / Lime wood / Tilleul / Linde / Tiglio
P10	2	2x3x20	Tilo / Lime wood / Tilleul / Linde / Tiglio
P11	1	2x3x19	Tilo / Lime wood / Tilleul / Linde / Tiglio
P12	1	2x3x22	Tilo / Lime wood / Tilleul / Linde / Tiglio
P13	2	1x80	Latón / Brass / Latón / Messing / Ottone
Q1	32	Preformado / Preformed/ Préformé / Vorgeformt / Preformato	Madera / Wood / Bois / Holz / Legno
Q2	2	2x3x32	Tilo / Lime wood / Tilleul / Linde / Tiglio
Q3	2	2x3x51	Tilo / Lime wood / Tilleul / Linde / Tiglio
Q4	2	Precortado / Precut / Prédécoupé / Vorgeschnitten / Pretagliatto	Tablero / Plywood / Planche / Sperrholz / Tavola
Q5	1	2x5x29	Tilo / Lime wood / Tilleul / Linde / Tiglio
Q6	2	2x6x27	Tilo / Lime wood / Tilleul / Linde / Tiglio
Q7	1	2x5x36	Tilo / Lime wood / Tilleul / Linde / Tiglio
Q8	2	2x5x56	Tilo / Lime wood / Tilleul / Linde / Tiglio
Q9	2	2x5x41	Tilo / Lime wood / Tilleul / Linde / Tiglio
Q10	12	3x3x6	Tilo / Lime wood / Tilleul / Linde / Tiglio
Q11	4	3x3x16	Tilo / Lime wood / Tilleul / Linde / Tiglio
Q12	4	Preformado / Preformed/ Préformé / Vorgeformt / Preformato	Latón / Brass / Latón / Messing / Ottone
Q13	34	Preformado / Preformed/ Préformé / Vorgeformt / Preformato	Latón / Brass / Latón / Messing / Ottone
Q14	4	Preformado / Preformed/ Préformé / Vorgeformt / Preformato	Latón / Brass / Latón / Messing / Ottone
Q15	2	Preformado / Preformed/ Préformé / Vorgeformt / Preformato	Latón / Brass / Latón / Messing / Ottone
Q16	1	ø1,5x10	Latón / Brass / Latón / Messing / Ottone
Q17	2	Precortado / Precut / Prédécoupé / Vorgeschnitten / Pretagliatto	Tablero / Plywood / Planche / Sperrholz / Tavola
Q18	1	Preformado / Preformed/ Préformé / Vorgeformt / Preformato	Madera / Wood / Bois / Holz / Legno
Q19	1	2x2x12	Tilo / Lime wood / Tilleul / Linde / Tiglio
Q20	4	Preformado / Preformed/ Préformé / Vorgeformt / Preformato	Latón / Brass / Latón / Messing / Ottone
R1	2	Precortado / Precut / Prédécoupé / Vorgeschnitten / Pretagliatto	Tablero / Plywood / Planche / Sperrholz / Tavola
R2	24	Preformado / Preformed/ Préformé / Vorgeformt / Preformato	Metal / Metal / Metal / Metall / Metallo
R3	10	Preformado / Preformed/ Préformé / Vorgeformt / Preformato	Metal / Metal / Metal / Metall / Metallo
R4-R5	30	Precortado / Precut / Prédécoupé / Vorgeschnitten / Pretagliatto	Tablero / Plywood / Planche / Sperrholz / Tavola
R6	20	ø1,5x15	Latón / Brass / Latón / Messing / Ottone
R7	40	Preformado / Preformed/ Préformé / Vorgeformt / Preformato	Madera / Wood / Bois / Holz / Legno
R8-R9	4	Precortado / Precut / Prédécoupé / Vorgeschnitten / Pretagliatto	Tablero / Plywood / Planche / Sperrholz / Tavola
R10	8	2x2x10	Tilo / Lime wood / Tilleul / Linde / Tiglio
R11	6	ø1x12	Latón / Brass / Latón / Messing / Ottone
R12	2	4x4x32	Tilo / Lime wood / Tilleul / Linde / Tiglio
R13	1	ø0,15x150	Hilo crudo / Raw thread / Fil brut / Rohes Baumwollfaden / Filo crudo
R14	4	Preformado / Preformed/ Préformé / Vorgeformt / Preformato	Madera / Wood / Bois / Holz / Legno
R14	2	ø1,5x70	Hilo marrón / Brown thread / Fil brun /braunes Baumwollfaden / Filo marrone
S1	1	Precortado / Precut / Prédécoupé / Vorgeschnitten / Pretagliatto	Tablero / Plywood / Planche / Sperrholz / Tavola









Lista de piezas / Parts List / Liste des pièces / Teileliste / Elenco delle parti

Nº/No./Nº / Nr. No	Cantidad / Quantity / Quantité / Menge / Quantità	Medidas / Measurements / Dimensions /Maße / Misure	Material / Material / Matériau / Material / Materiale
S2-S8	16	Precortado / Precut / Prédécoupé / Vorgeschnitten / Pretagliatto	Tablero / Plywood / Planche / Sperrholz / Tavola
S9	1	Precortado / Precut / Prédécoupé / Vorgeschnitten / Pretagliatto	Tablero / Plywood / Planche / Sperrholz / Tavola
S10	2	Precortado / Precut / Prédécoupé / Vorgeschnitten / Pretagliatto	Tablero / Plywood / Planche / Sperrholz / Tavola
S11	18	1x3x110	Tilo / Lime wood / Tilleul / Linde / Tiglio
S12	1	2x2x47	Tilo / Lime wood / Tilleul / Linde / Tiglio
S13	4	2x2x44	Tilo / Lime wood / Tilleul / Linde / Tiglio
S14	1	Precortado / Precut / Prédécoupé / Vorgeschnitten / Pretagliatto	Tablero / Plywood / Planche / Sperrholz / Tavola
S15	1	2x2x55	Tilo / Lime wood / Tilleul / Linde / Tiglio
S16	1	Precortado / Precut / Prédécoupé / Vorgeschnitten / Pretagliatto	Tablero / Plywood / Planche / Sperrholz / Tavola
S17	5	1x3x31	Tilo / Lime wood / Tilleul / Linde / Tiglio
S18	2	1x3x85	Tilo / Lime wood / Tilleul / Linde / Tiglio
S19	1	1x3x24	Tilo / Lime wood / Tilleul / Linde / Tiglio
T1	2	Preformado / Preformed/ Préformé / Vorgeformt / Preformato	Metal / Metal / Metal / Metall / Metallo
T2	2	Preformado / Preformed/ Préformé / Vorgeformt / Preformato	Metal / Metal / Metal / Metall / Metallo
T3	2	Preformado / Preformed/ Préformé / Vorgeformt / Preformato	Latón / Brass / Latón / Messing / Ottone
T4	2	ø1,5x350	Hilo marrón / Brown thread / Fil brun /braunes Baumwollfaden / Filo marrone
T5	2	ø0,15x100	Hilo crudo / Raw thread / Fil brut / Rohes Baumwollfaden / Filo crudo
T6-T8	5	Precortado / Precut / Prédécoupé / Vorgeschnitten / Pretagliatto	Tablero / Plywood / Planche / Sperrholz / Tavola
T9	2	Preformado / Preformed/ Préformé / Vorgeformt / Preformato	Latón / Brass / Latón / Messing / Ottone
T10	2	8x18	Acetato / Acetate / Acétate / Acetat / Acetato
T11	1	Preformado / Preformed/ Préformé / Vorgeformt / Preformato	Metal / Metal / Metal / Metall / Metallo
T12-T14	4	Precortado / Precut / Prédécoupé / Vorgeschnitten / Pretagliatto	Tablero / Plywood / Planche / Sperrholz / Tavola
T15	2	3x3x5	Tilo / Lime wood / Tilleul / Linde / Tiglio
T16	2	1x3x18	Tilo / Lime wood / Tilleul / Linde / Tiglio
T17	1	ø0,15x300	Hilo crudo / Raw thread / Fil brut / Rohes Baumwollfaden / Filo crudo
U1	42	ø0,50x100	Hilo marrón / Brown thread / Fil brun /braunes Baumwollfaden / Filo marrone
U2	2	Preformado / Preformed/ Préformé / Vorgeformt / Preformato	Latón / Brass / Latón / Messing / Ottone
U3	1	ø0,15x200	Hilo crudo / Raw thread / Fil brut / Rohes Baumwollfaden / Filo crudo
U4	3	ø0,15x250	Hilo crudo / Raw thread / Fil brut / Rohes Baumwollfaden / Filo crudo
U5	10	ø0,50x150	Hilo marrón / Brown thread / Fil brun /braunes Baumwollfaden / Filo marrone
U6	4	ø0,15x200	Hilo crudo / Raw thread / Fil brut / Rohes Baumwollfaden / Filo crudo

Lista de piezas / Parts List / Liste des pièces / Teileliste / Elenco delle parti

Nº/No./Nº / Nr. / No	Descripción / Description / Description / Beschreibung / Descrizione	Cantidad / Quantity / Quantité / Menge / Quantità	Material / Material / Matériau / Material / Materiale
A		800	Metal / Metal / Metal / Metall / Metallo
B		17	Latón / Brass / Latón / Messing / Ottone
C		124	Hilo crudo / Raw thread / Fil brut / Rohes Baumwollfaden / Filo crudo

Lista de piezas / Parts List / Liste des pièces / Teilleiste / Elenco delle parti

Nº/No./Nº / Nr. No	Cantidad / Quantity / Quantité / Menge / Quantità	Medidas / Measurements / Dimensions /Maße / Misure	Material / Material / Matériau / Material / Materiale
D		120	Madera / Wood / Bois / Holz / Legno
E		17	Madera / Wood / Bois / Holz / Legno
F		60	Madera / Wood / Bois / Holz / Legno
G		64	Madera / Wood / Bois / Holz / Legno
H		24	Latón / Brass / Latón / Messing / Ottone
J		57	Madera / Wood / Bois / Holz / Legno
K		3	Cristal / Glass / Verre / Glas / Vetro
M		10	Madera / Wood / Bois / Holz / Legno

Fotos paso a paso y hojas de identificación de piezas
Step by step photos and part identification sheets
Photos pas-à-pas et feuilles d'identification des pièces
Foto passo-passo e schede di identificazione dei pezzi
Bebilderte schritt-für-schritt-anleitung
und liste mit teilekennzeichnung



Accede a videos tutoriales fotografiando los códigos QR.
Access tutorial videos photographing QR codes.
Accédez aux didacticiels vidéo photographiant les codes QR.
Greifen Sie auf Video-Tutorials zu, die QR-Code fotografieren.
Accedi ai video tutorial fotografando i codici QR.
Доступ к видеоурокам фотографирования QR-кодов.

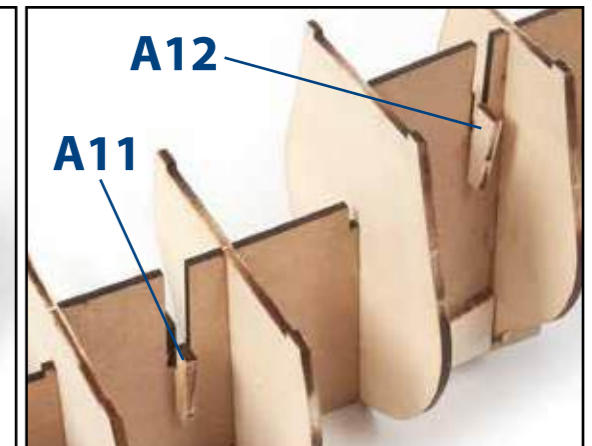
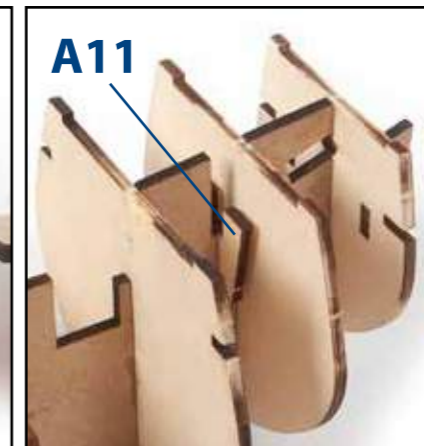
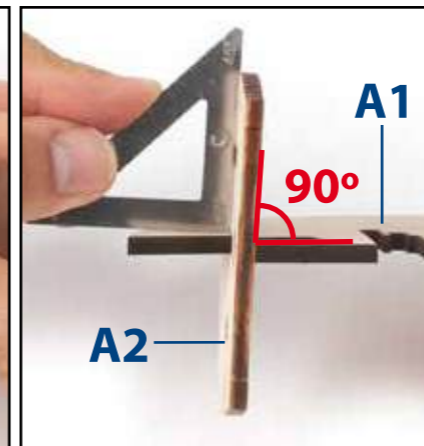
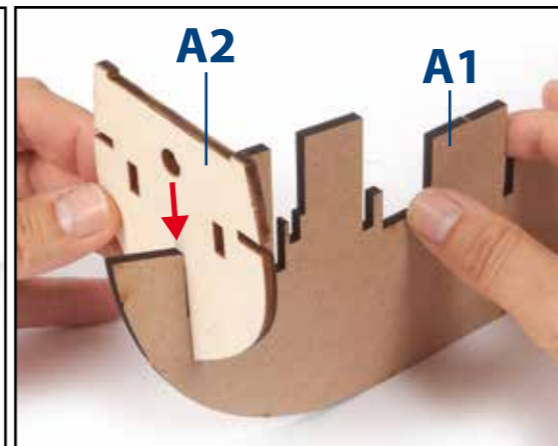
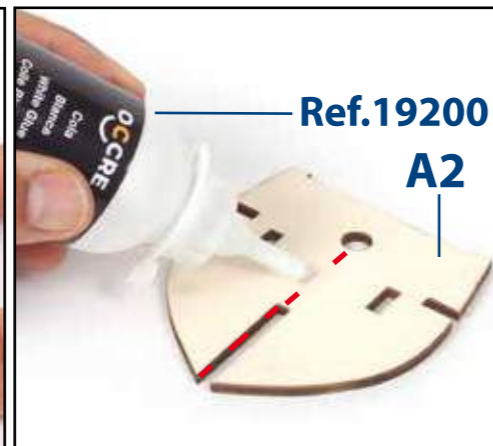
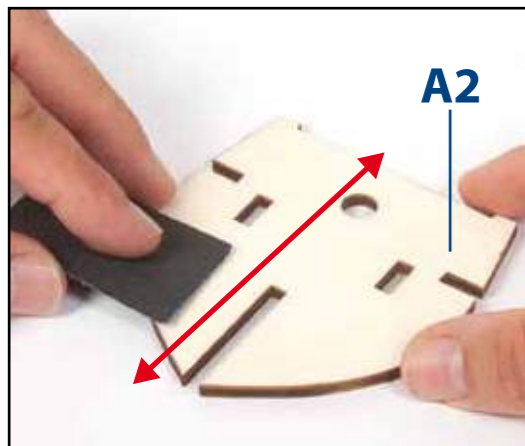
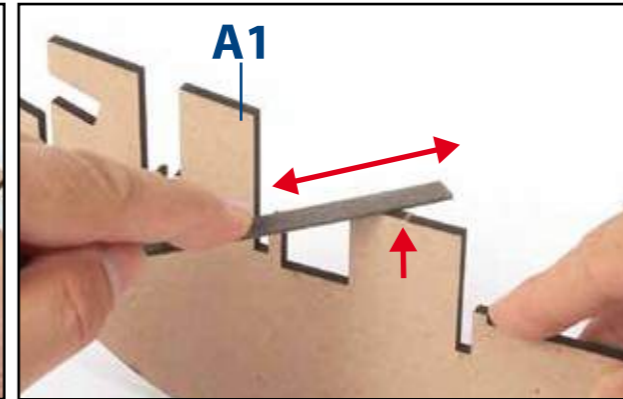
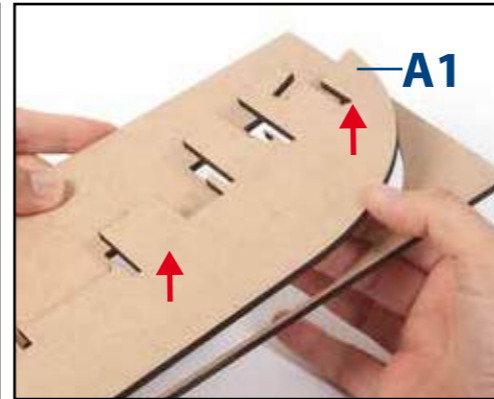
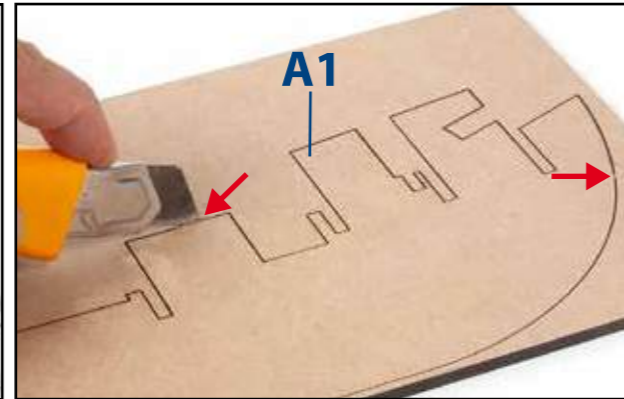
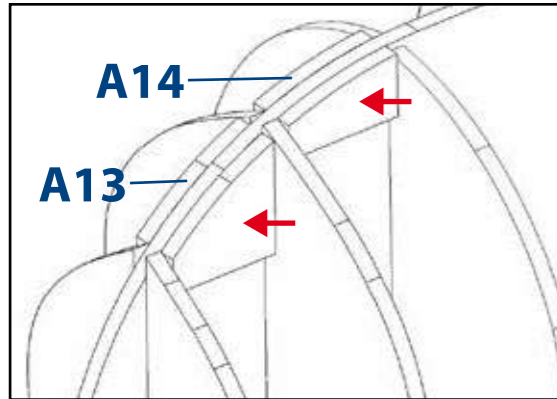
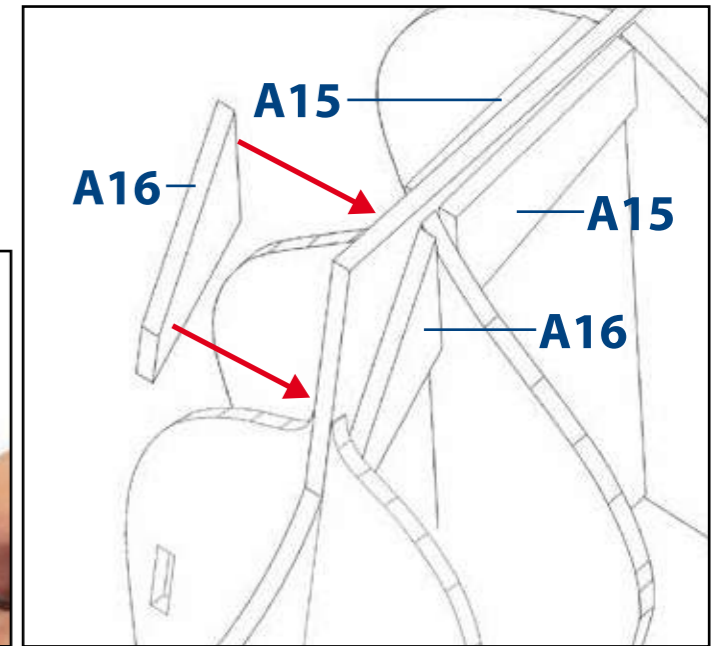
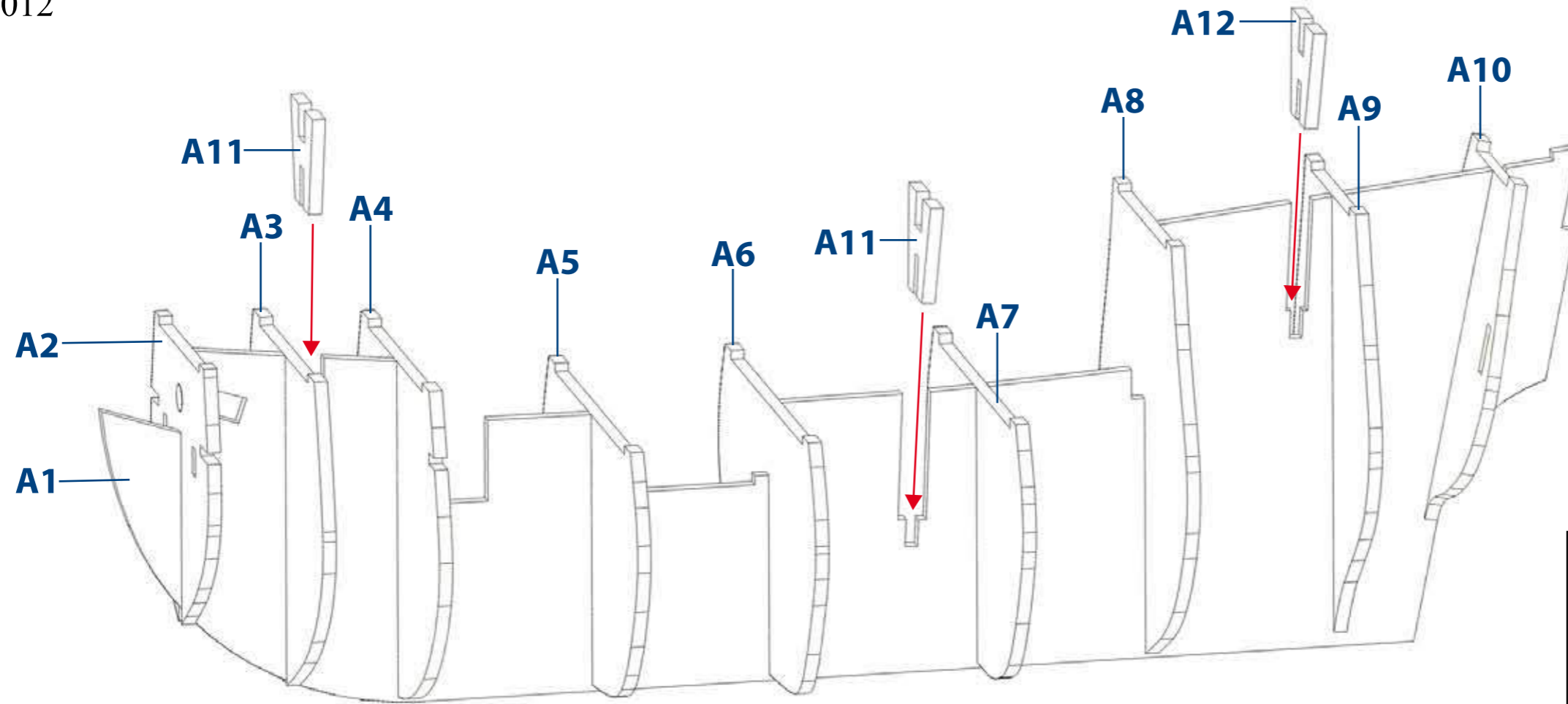

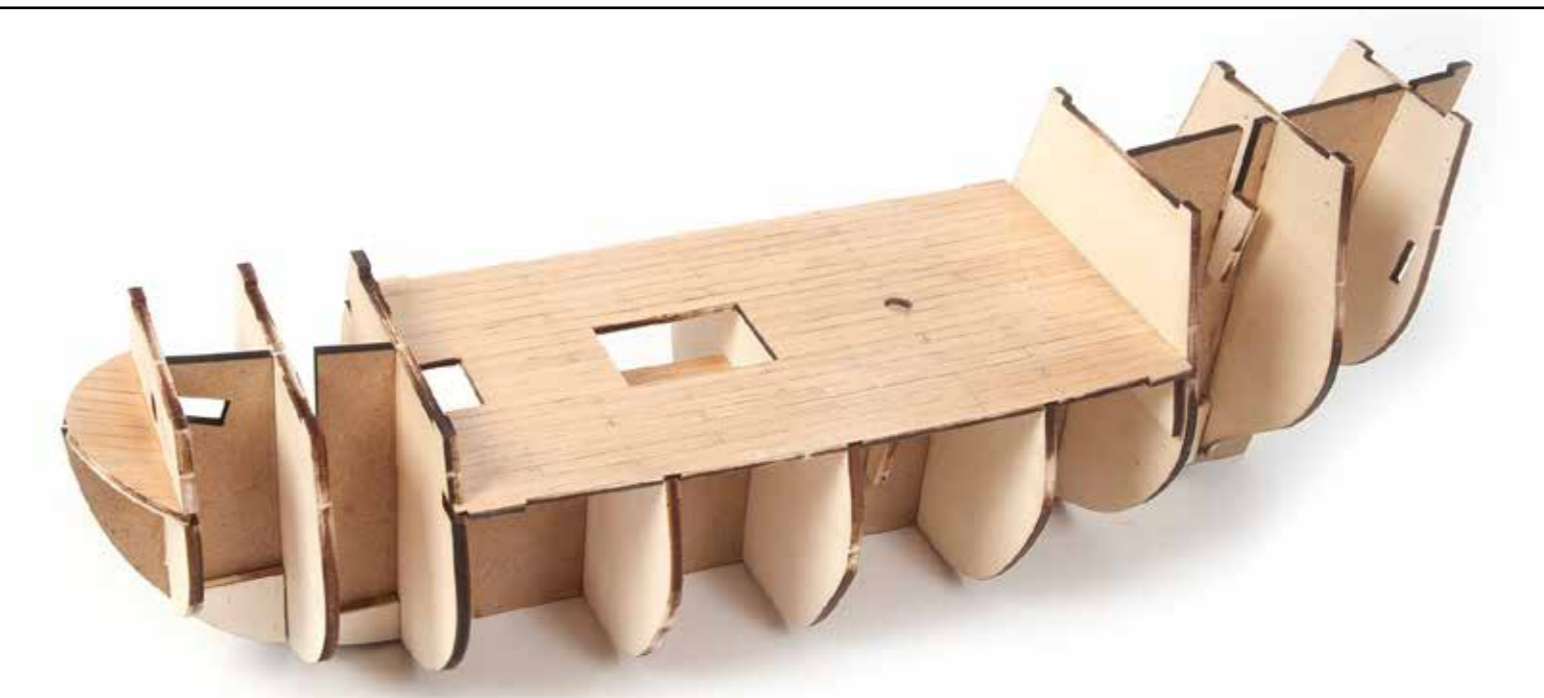
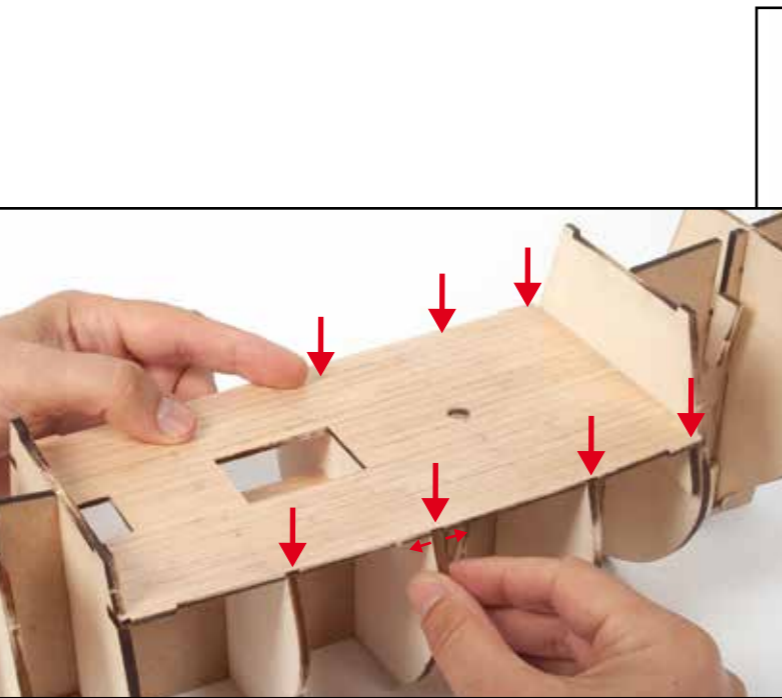
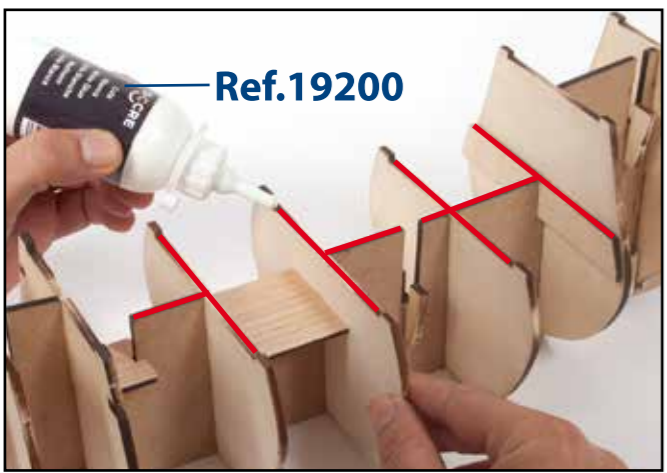
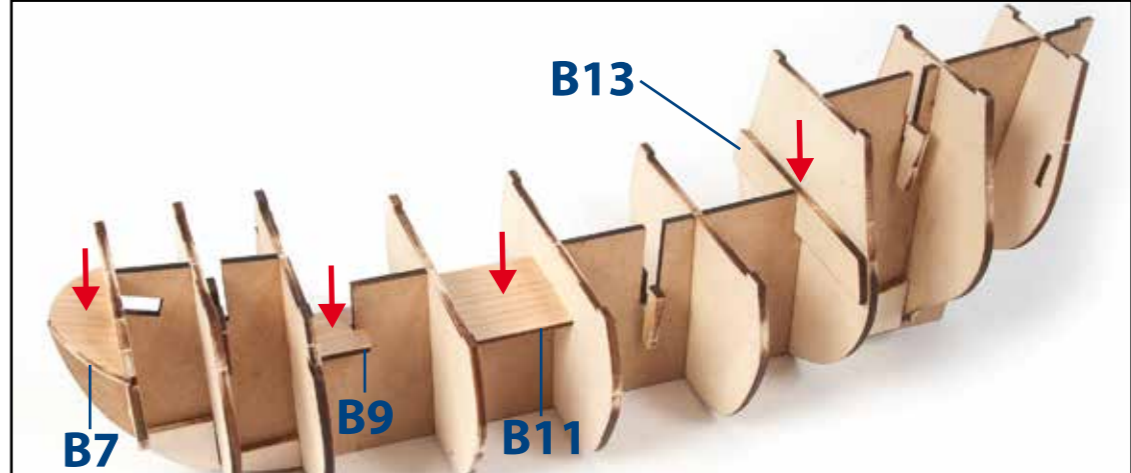
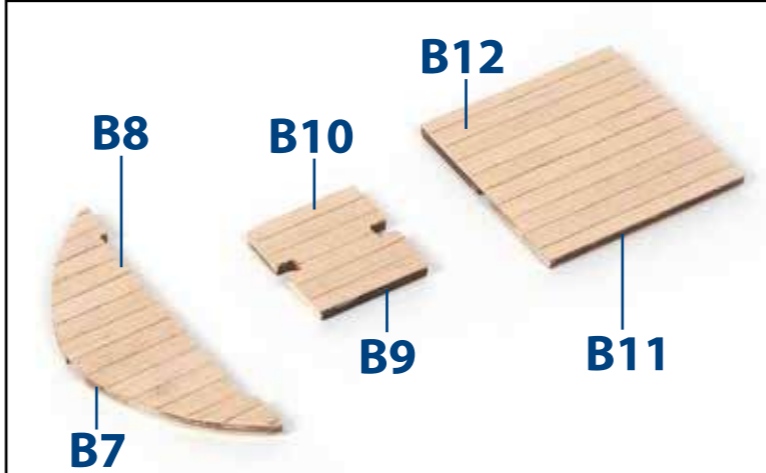
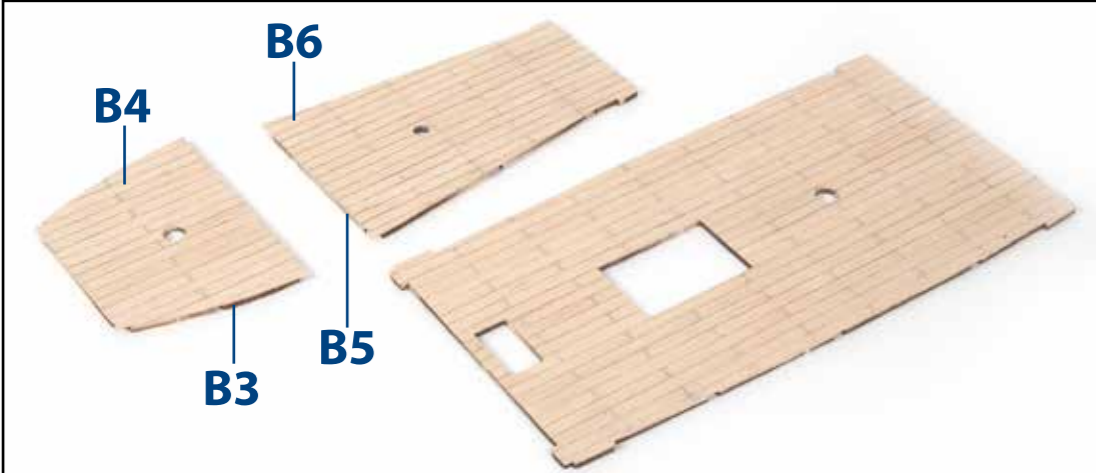
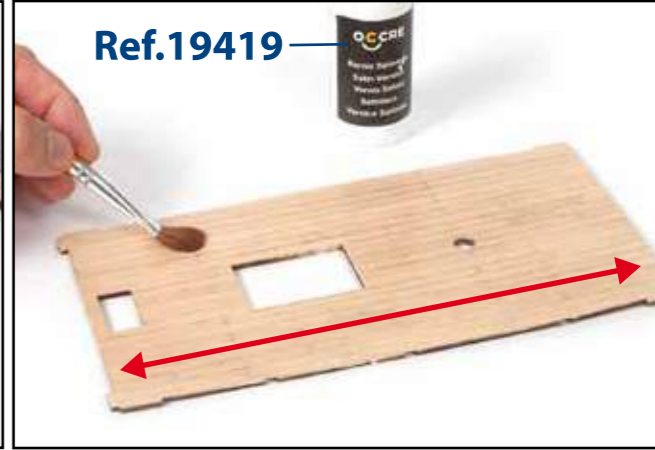
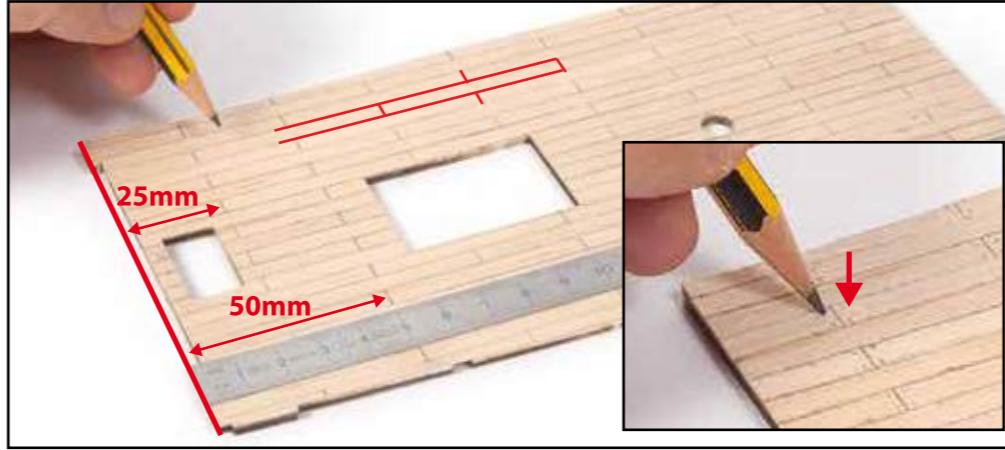
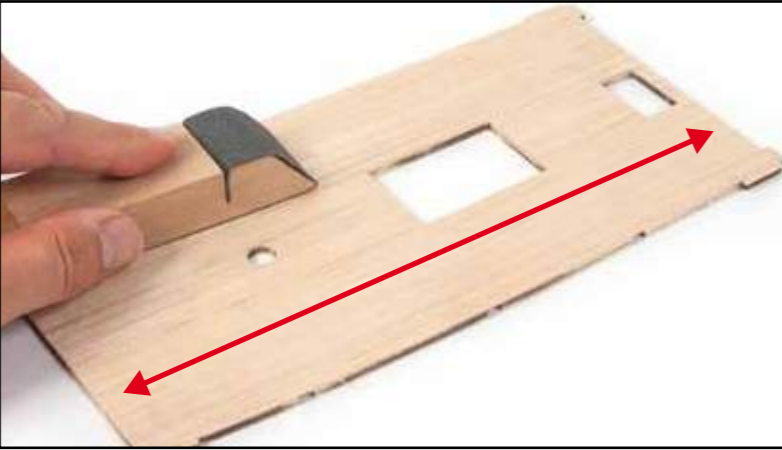
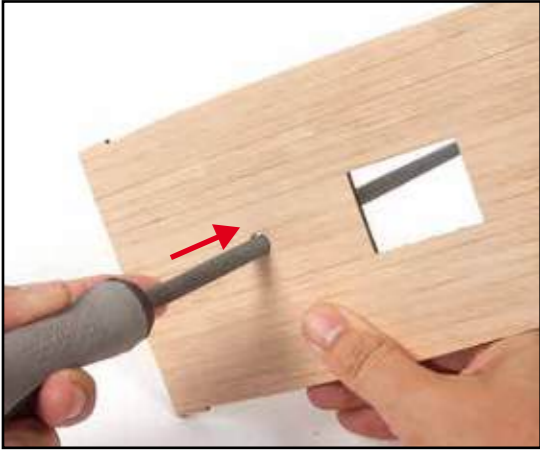
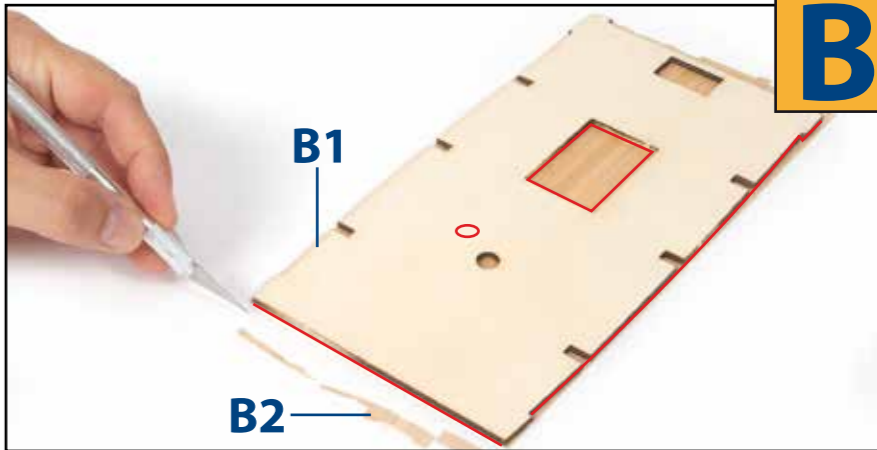
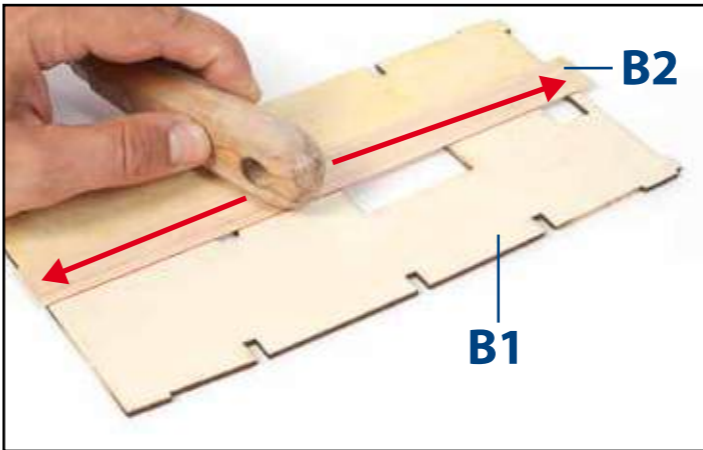
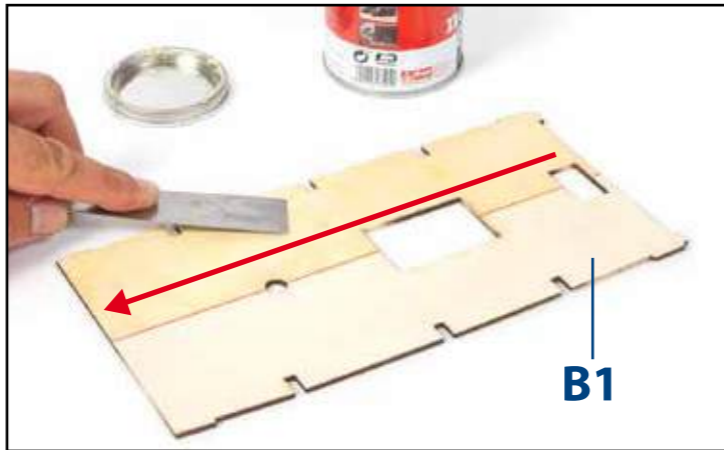
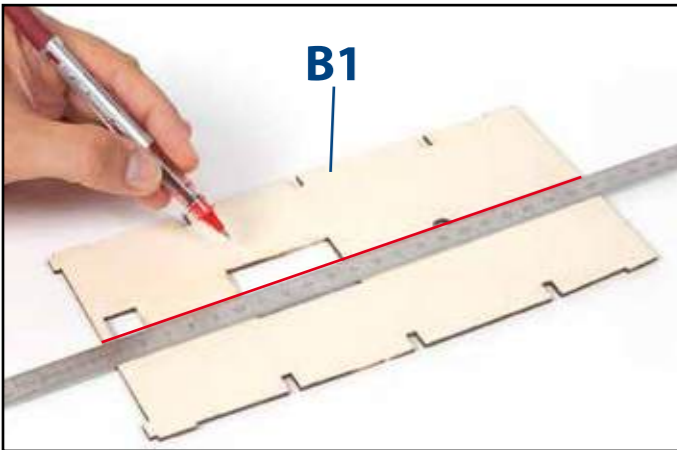

C

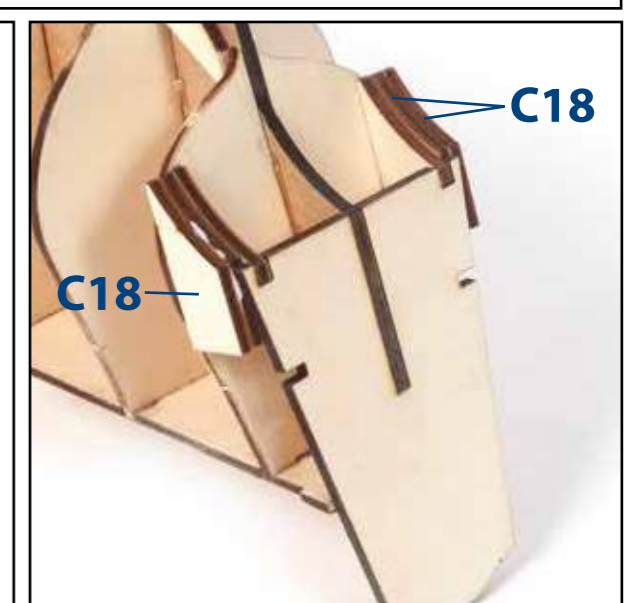
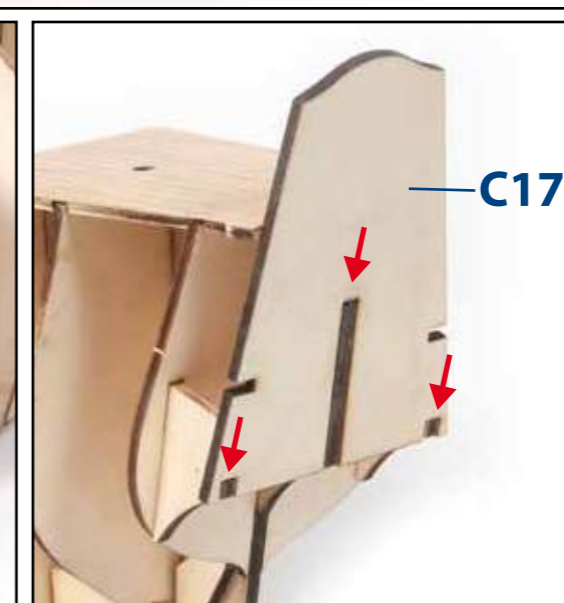
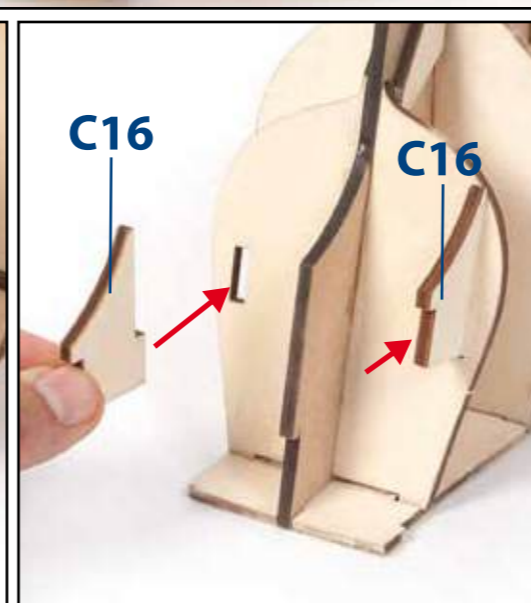
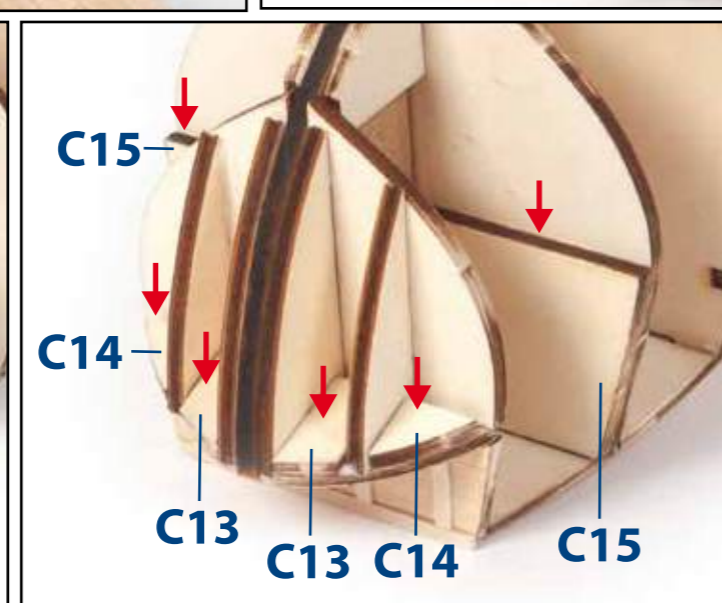
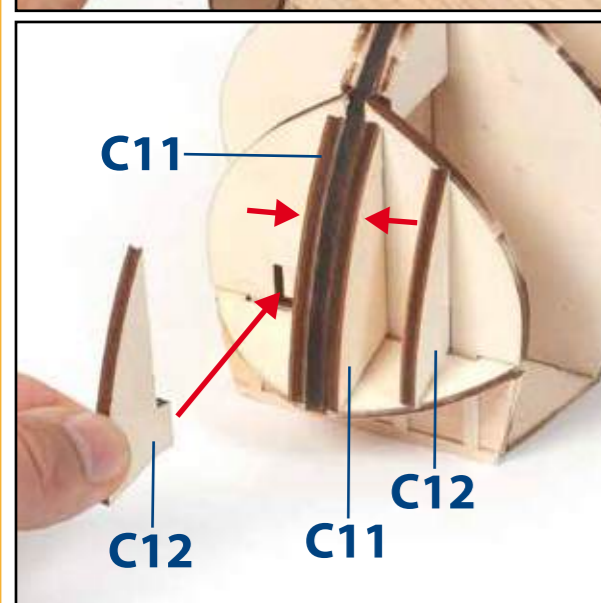
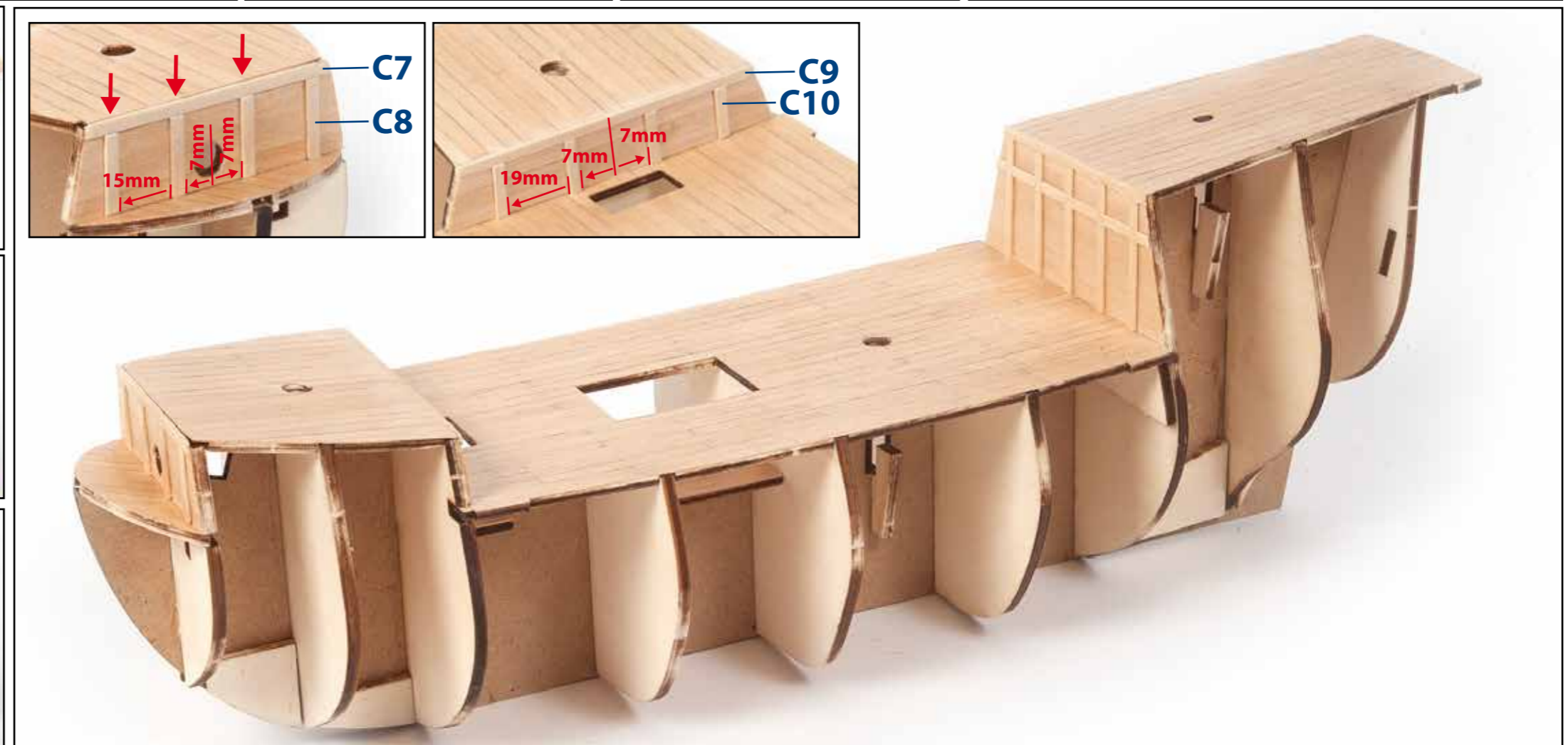
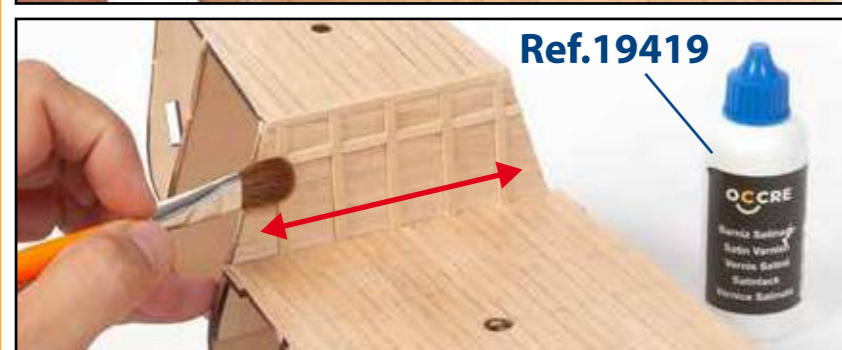
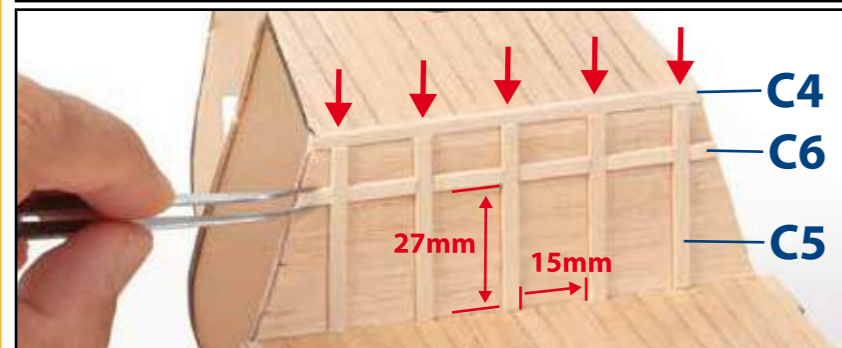
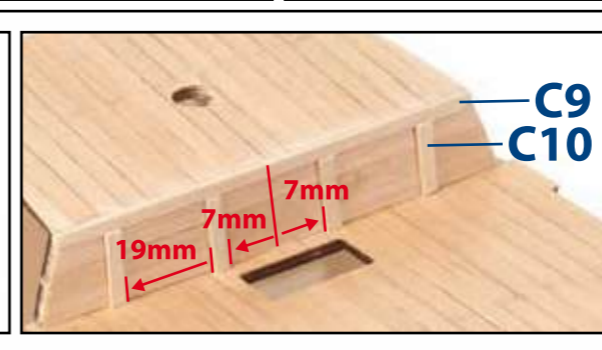
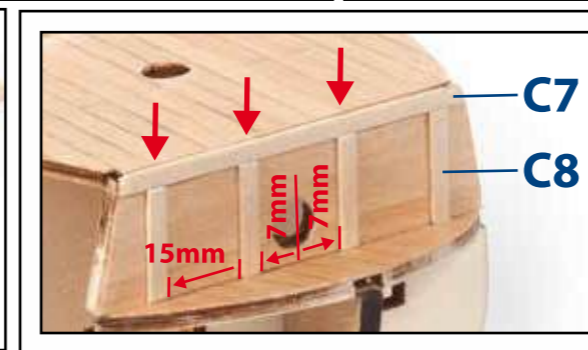
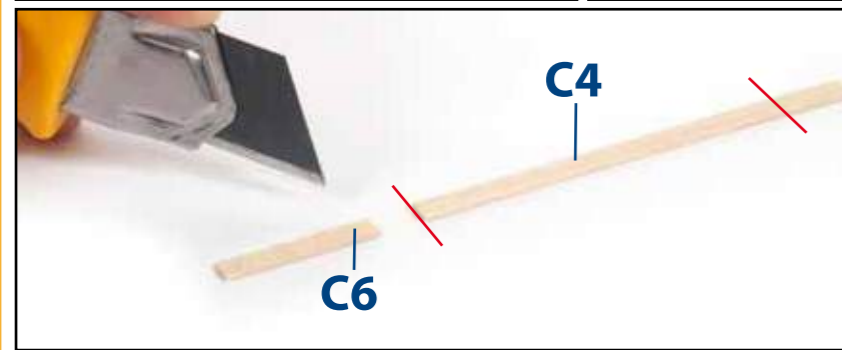
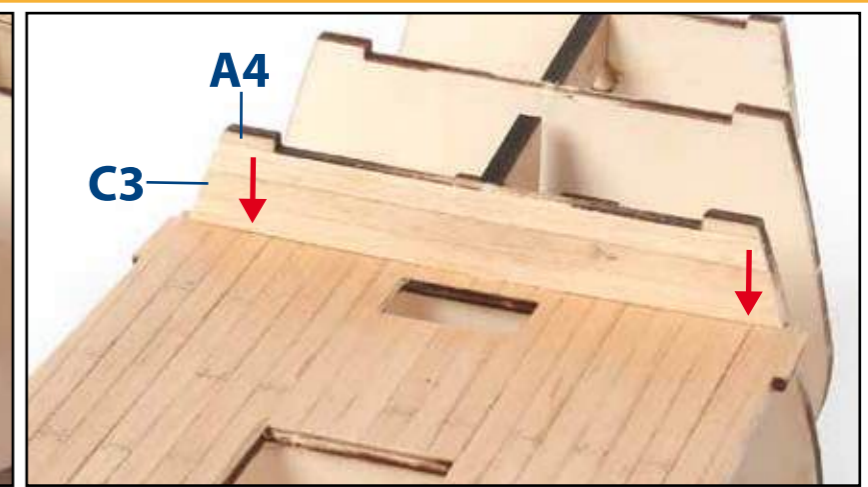
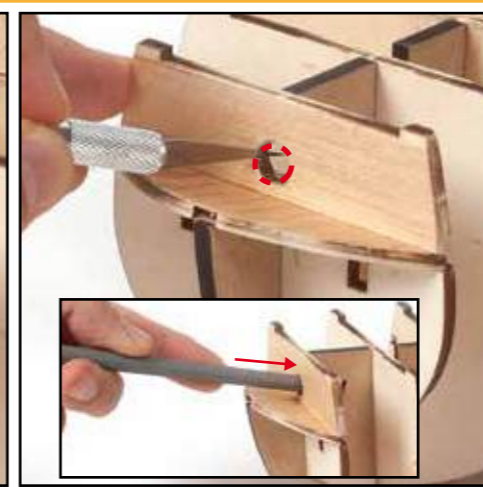
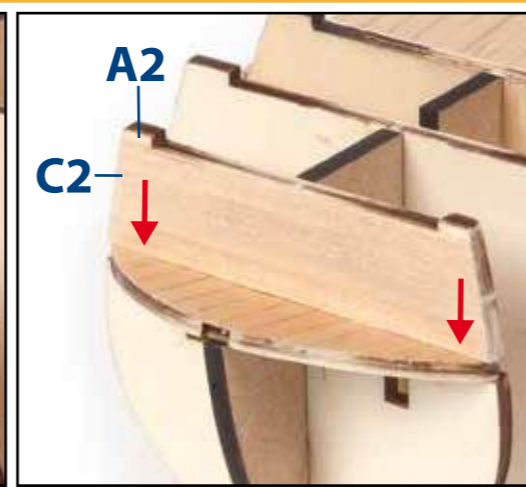
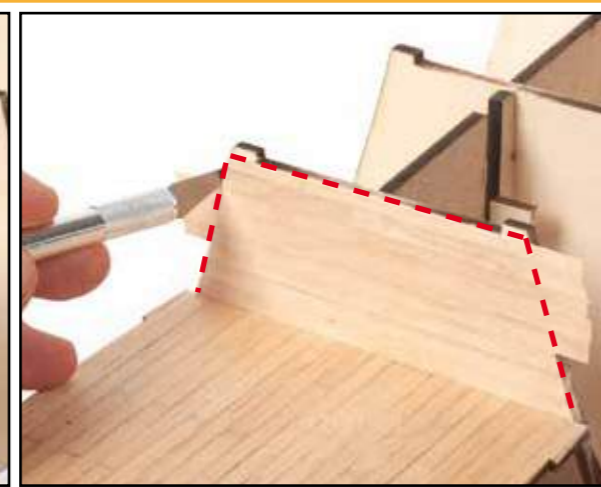
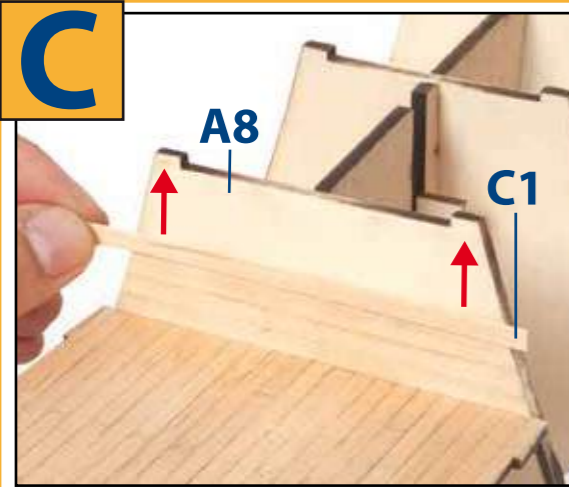

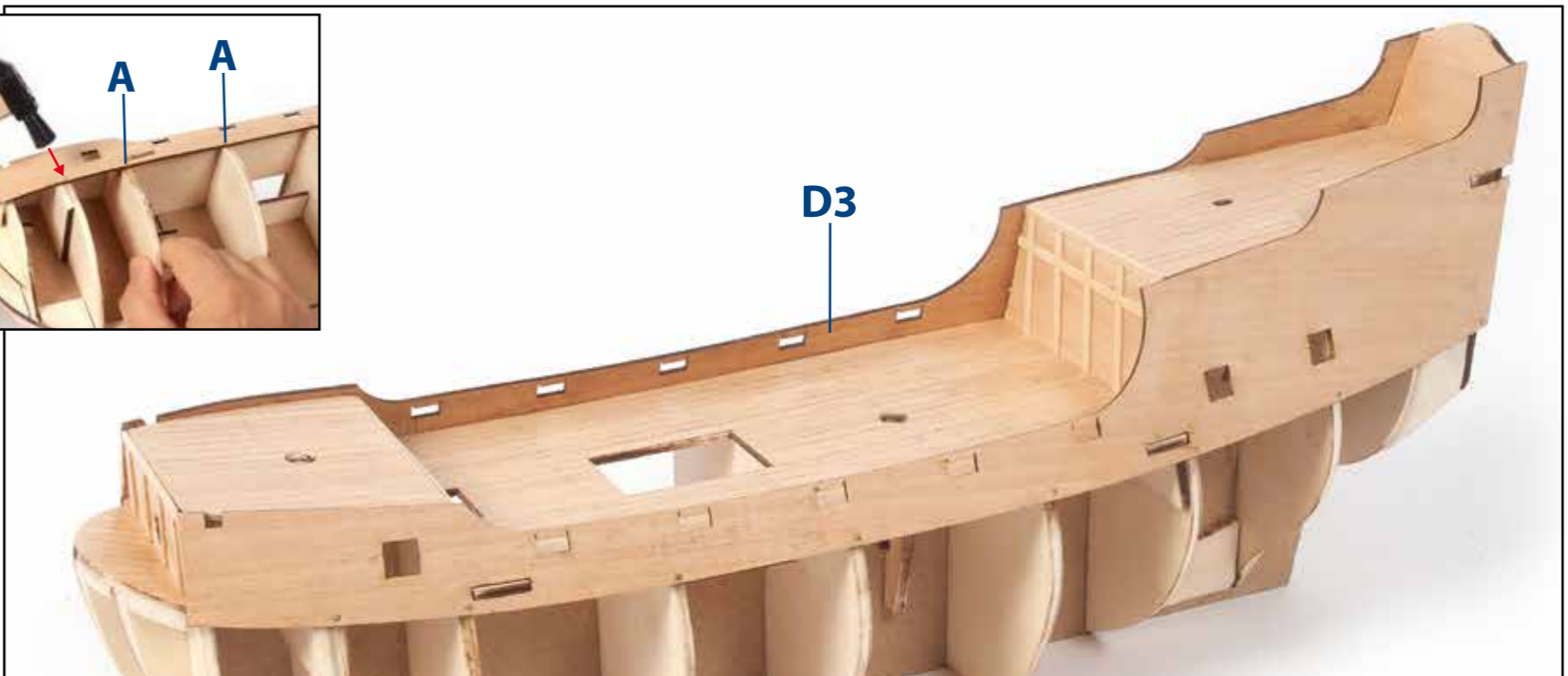
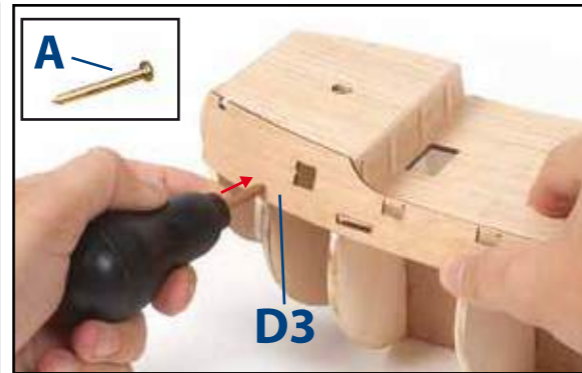
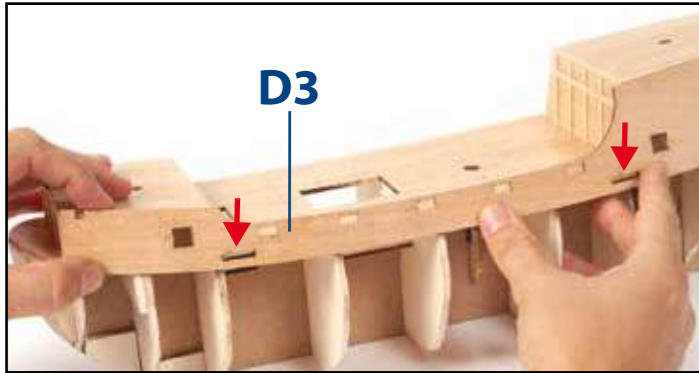
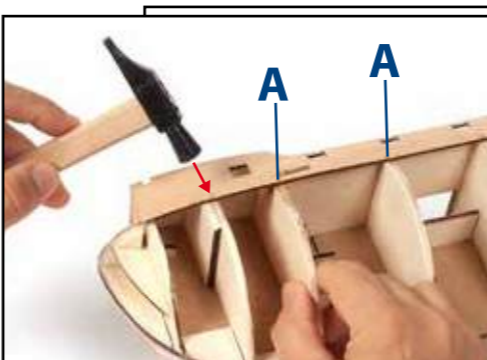
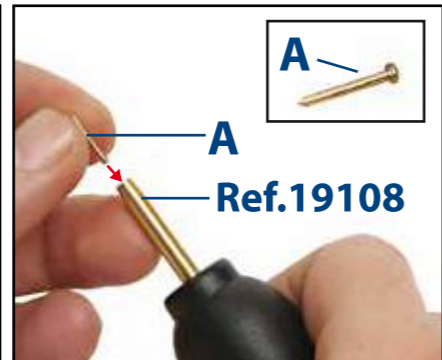
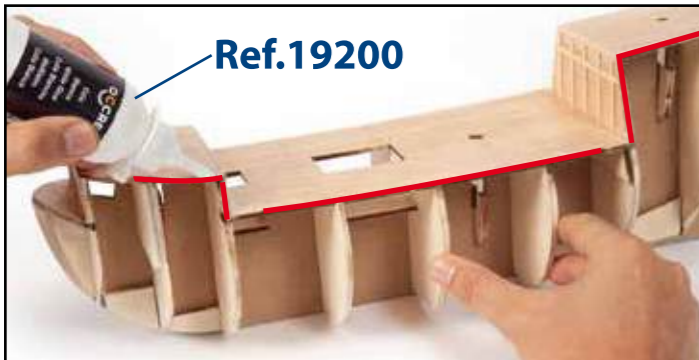
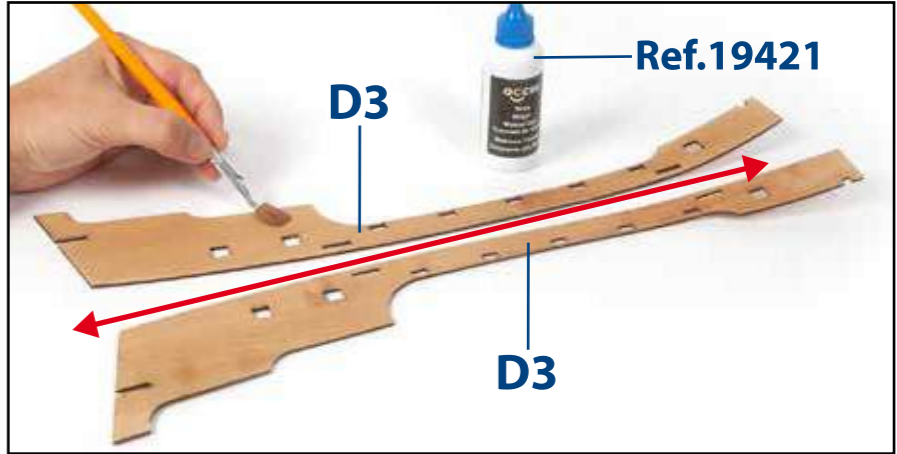
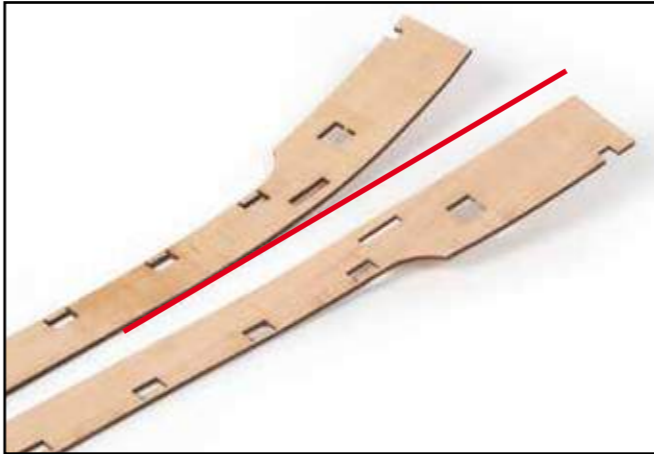
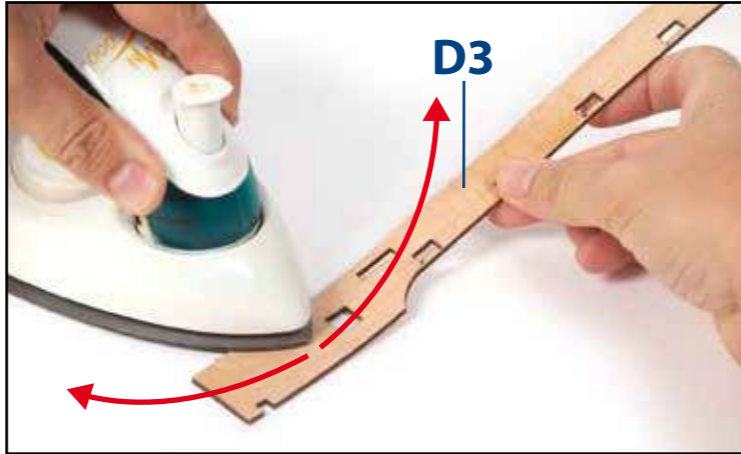
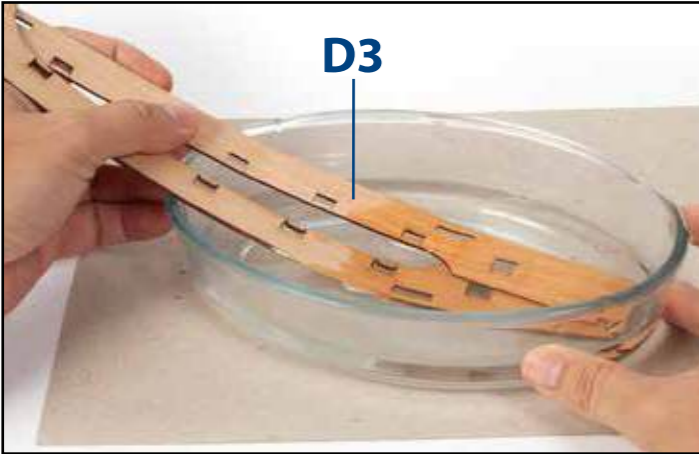
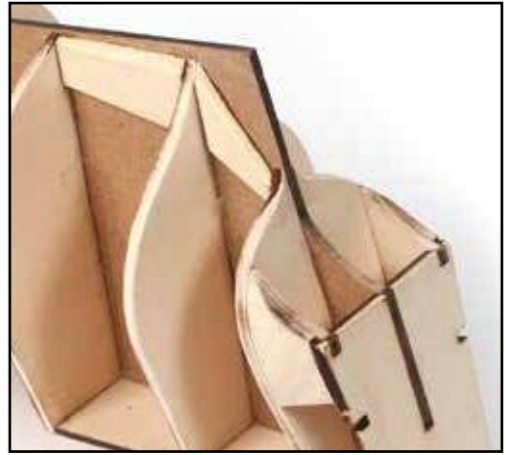
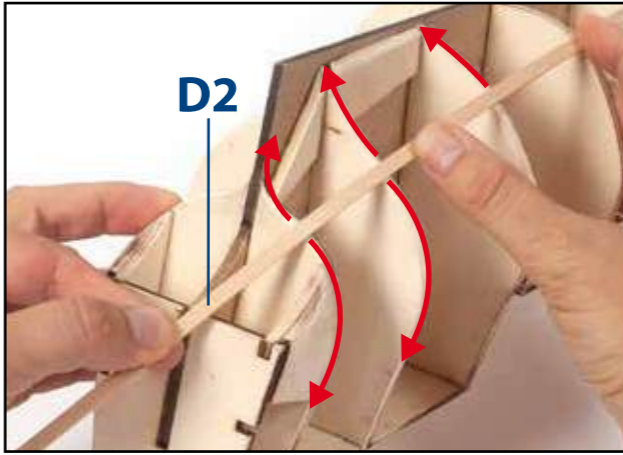
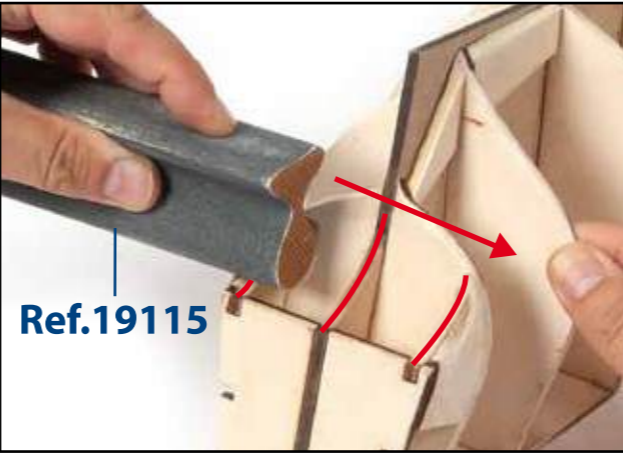
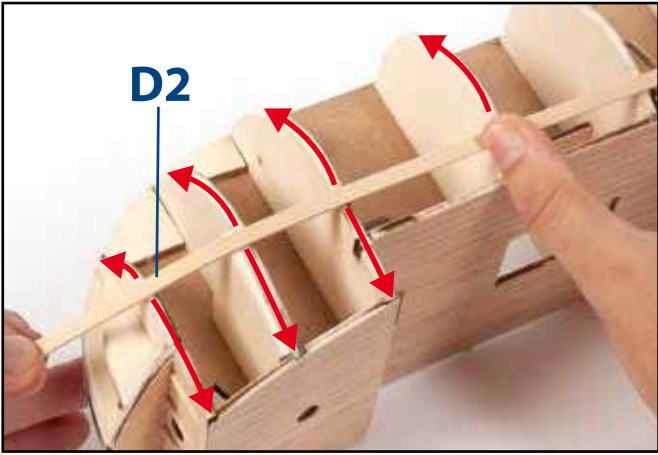
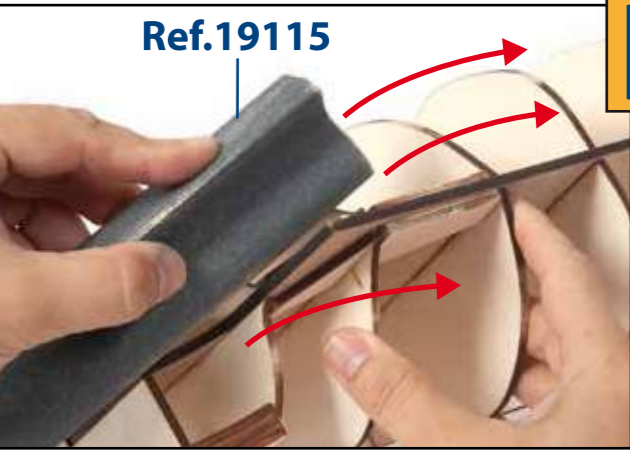
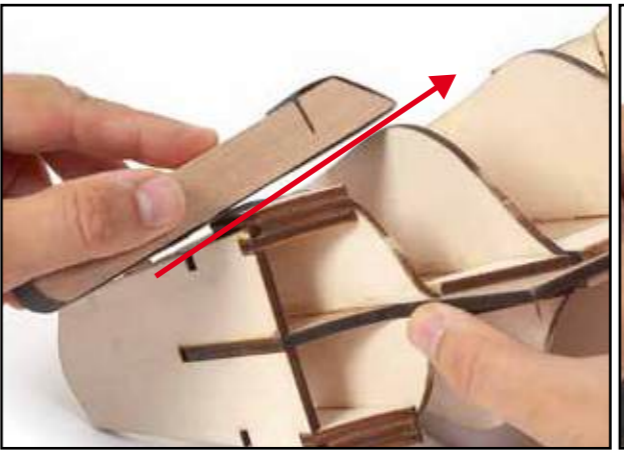
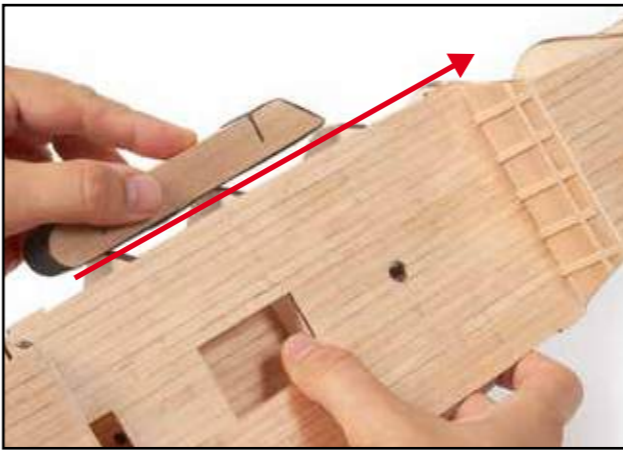
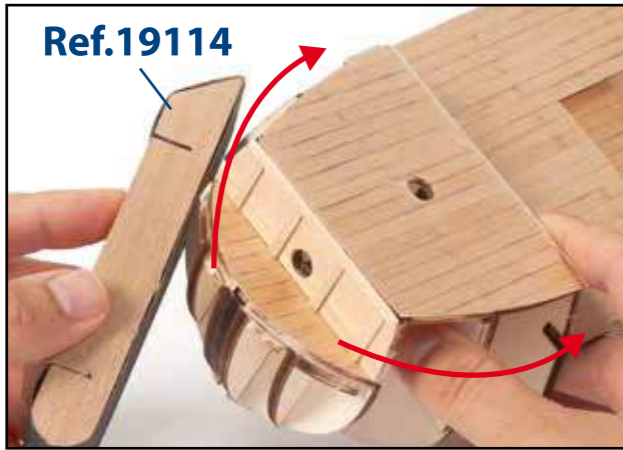

E

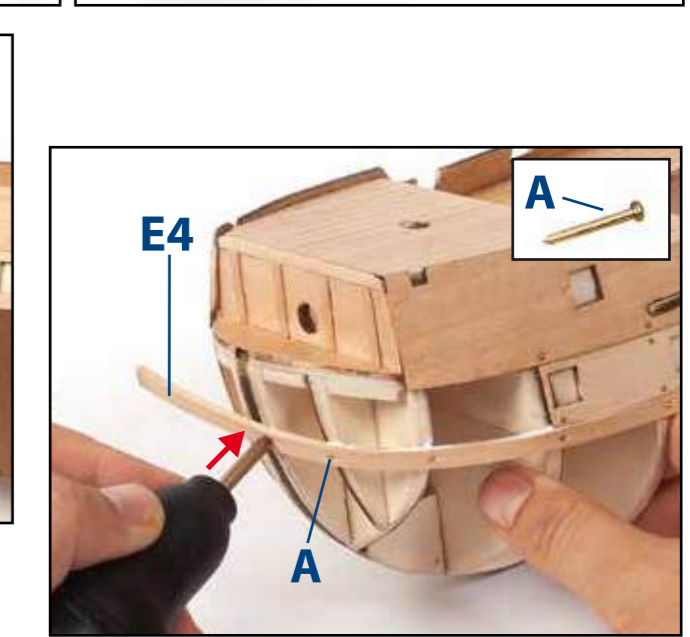
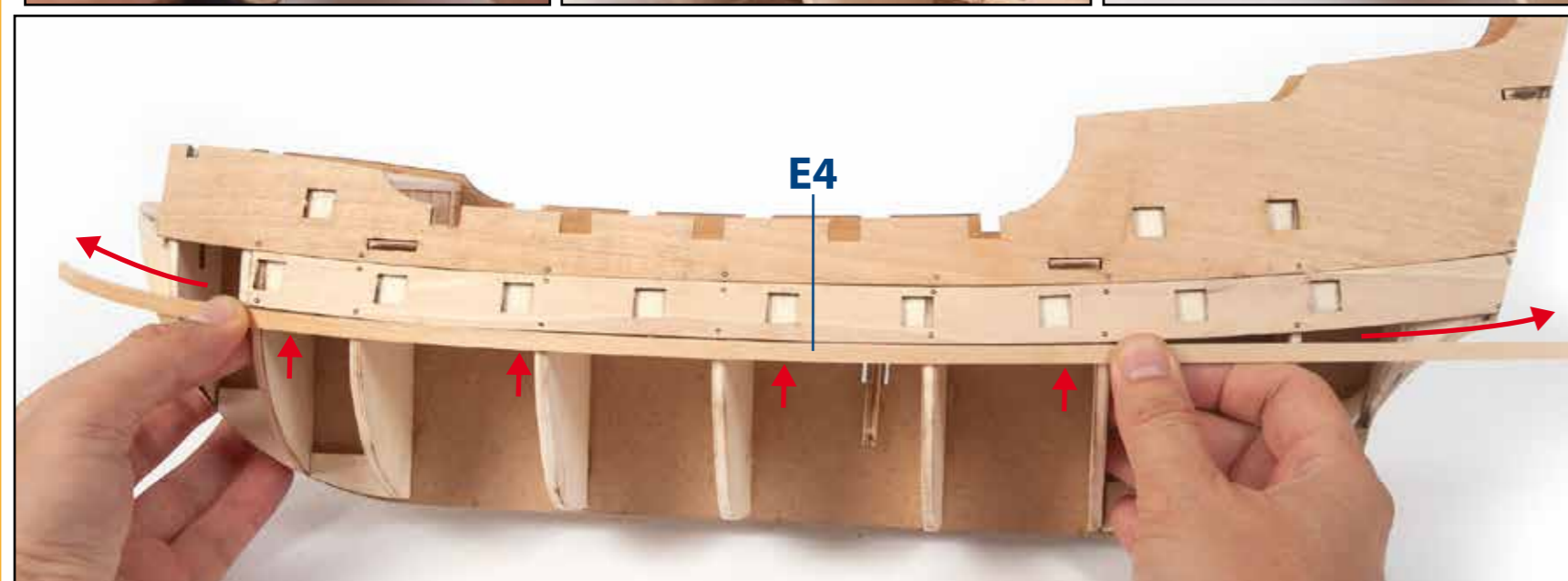
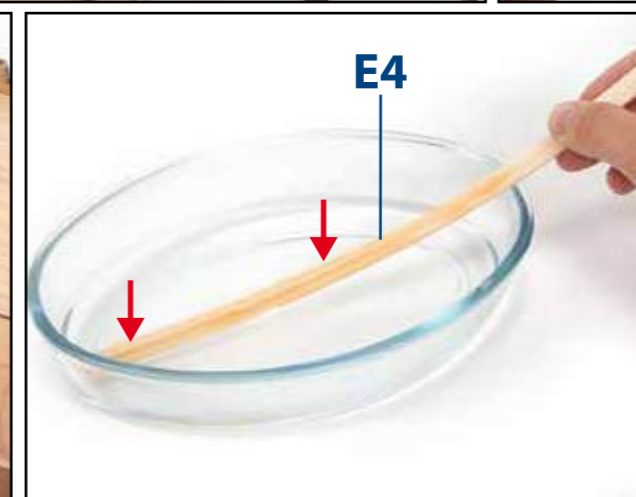
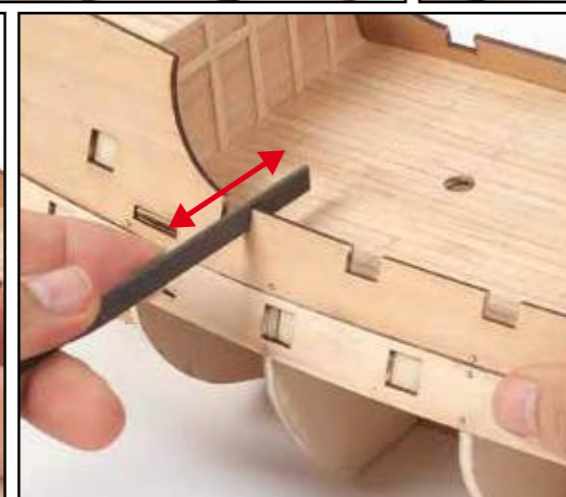
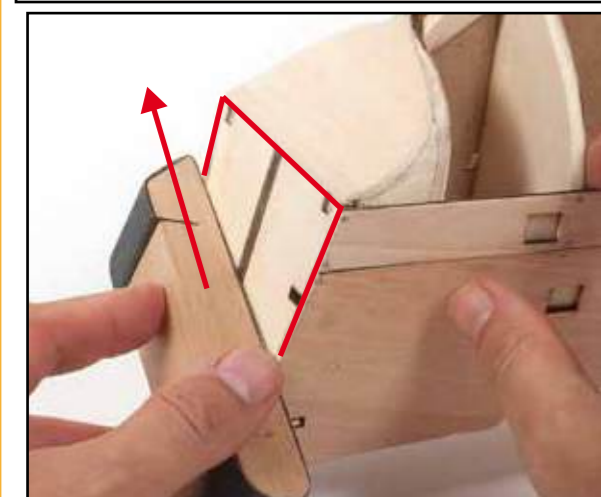
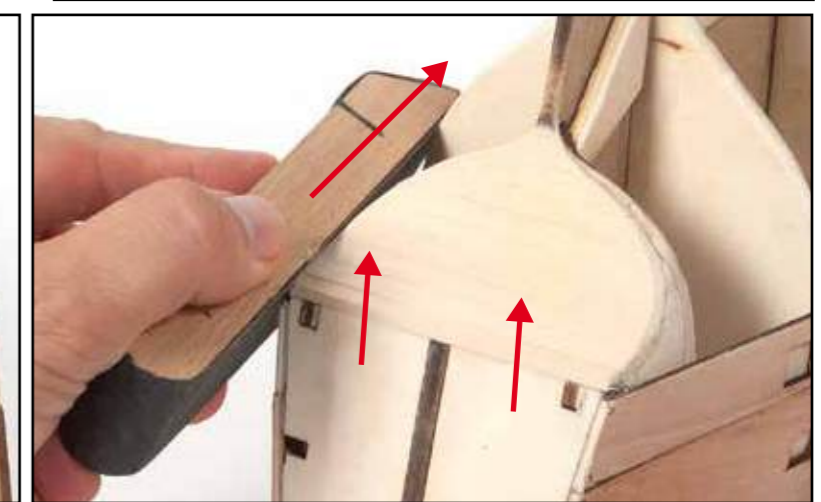
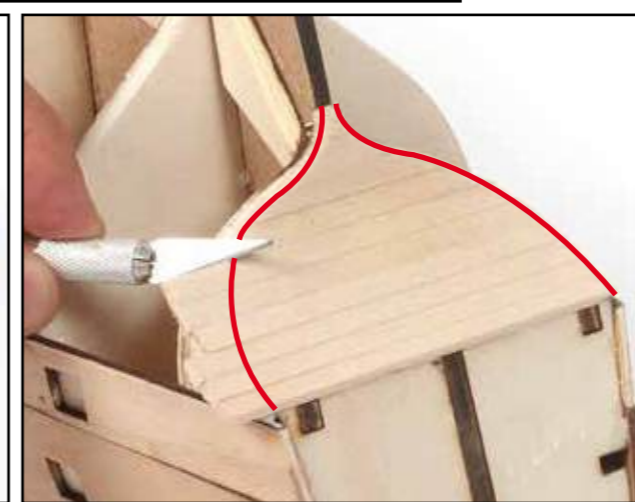
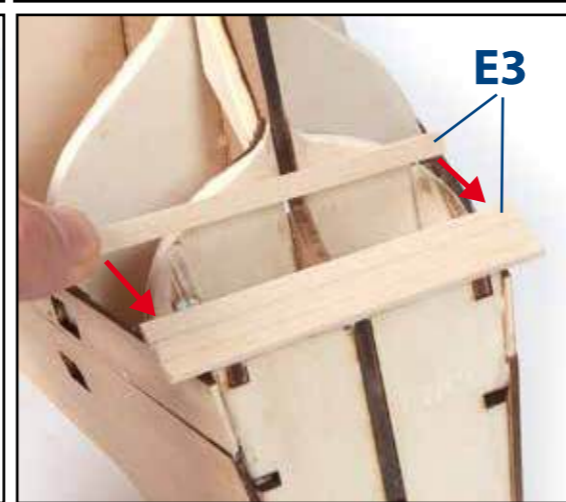
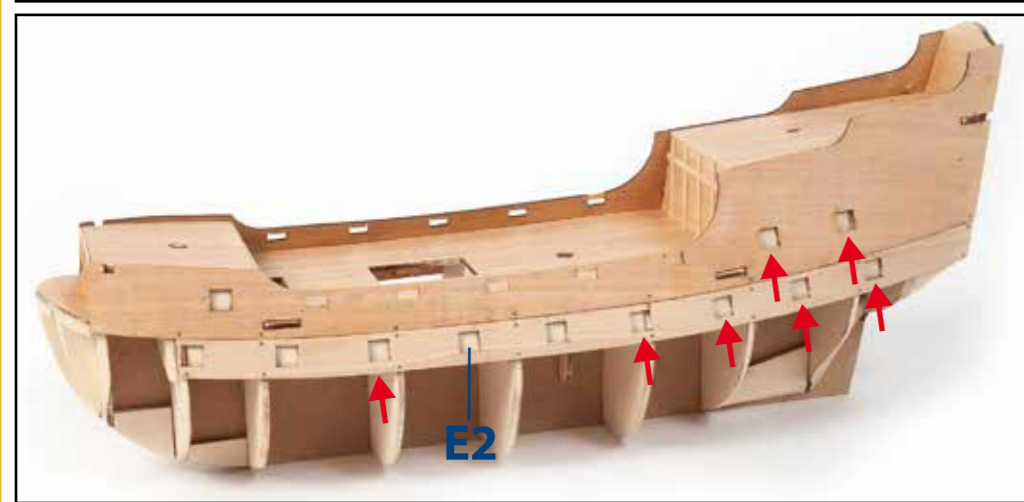
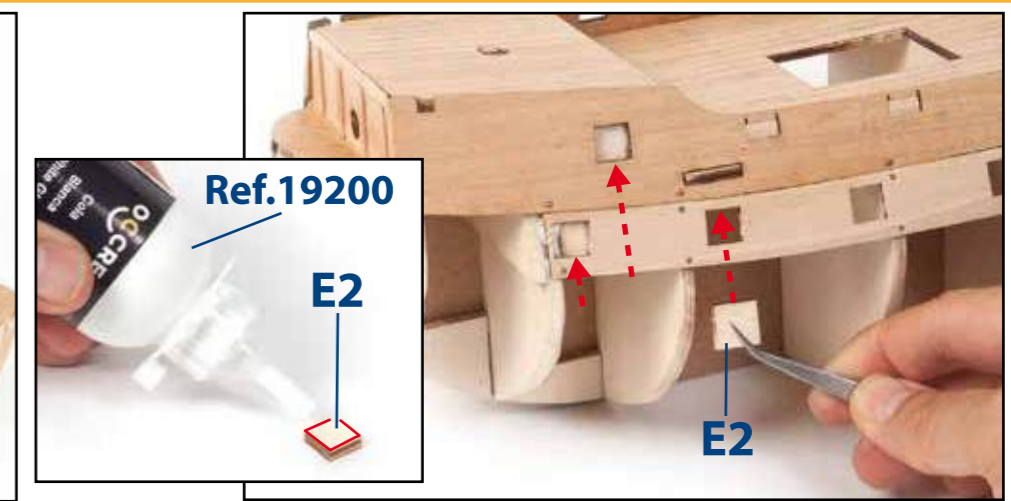
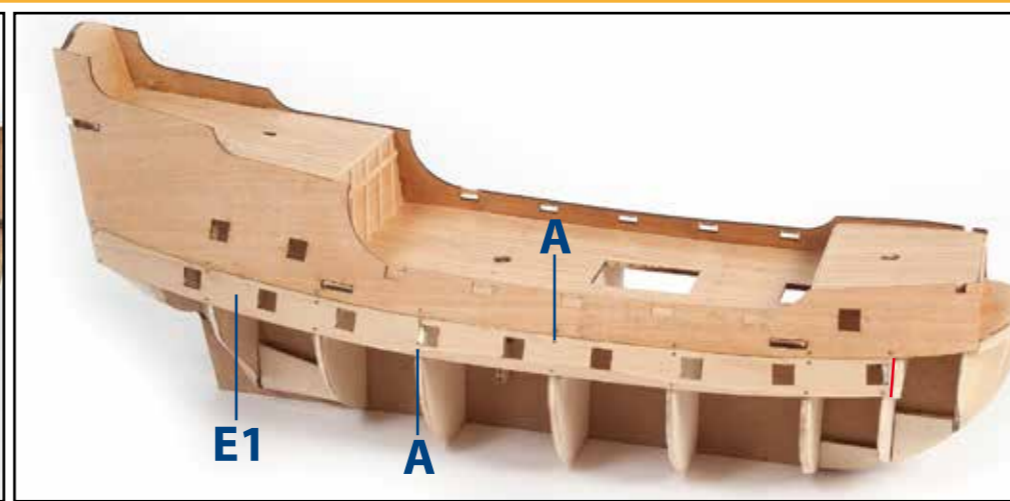

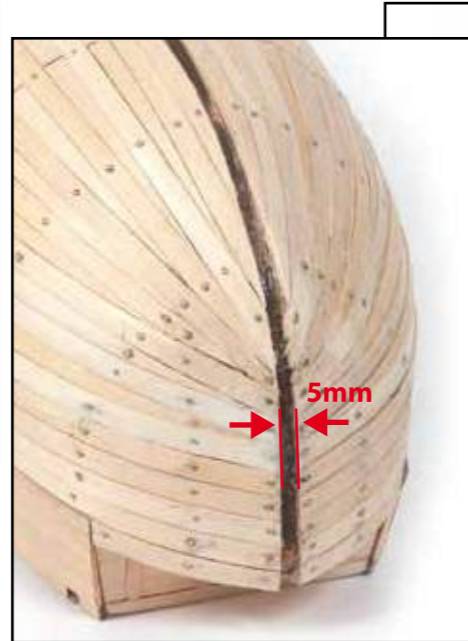
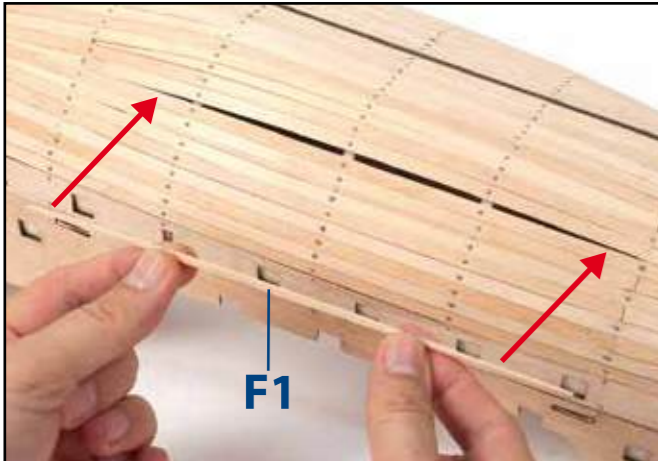
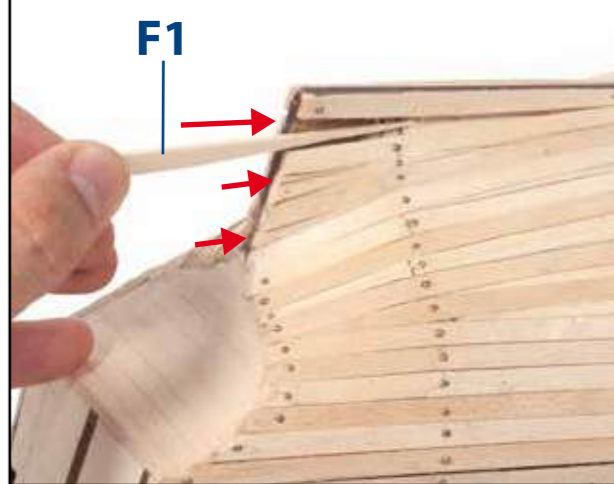
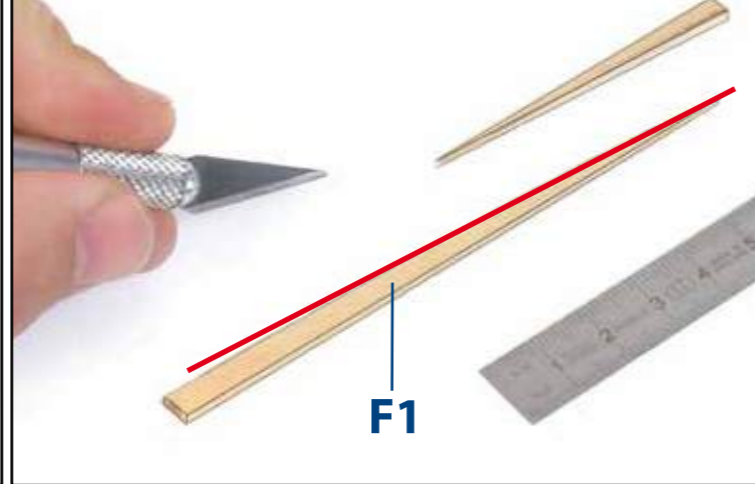
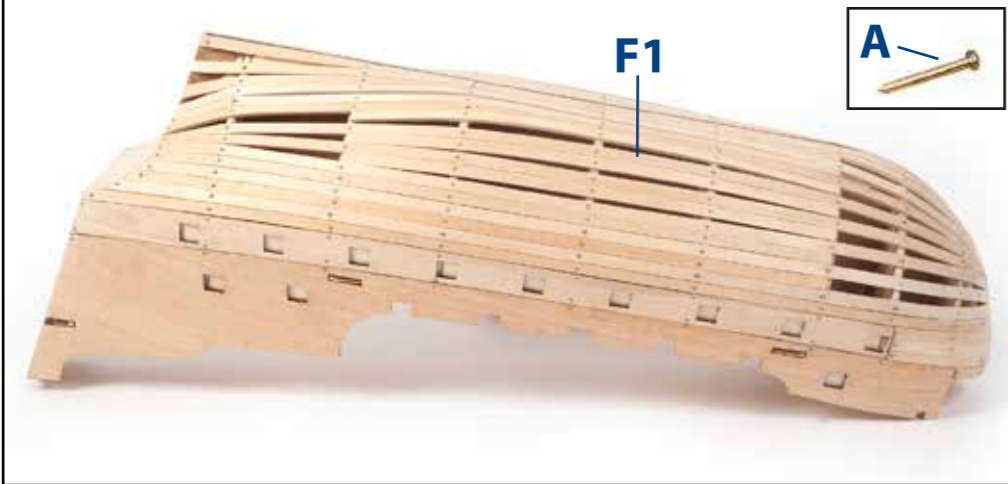
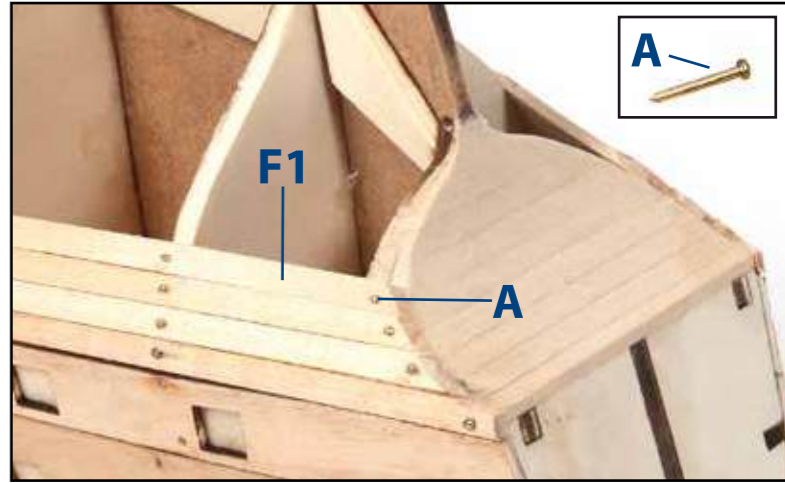
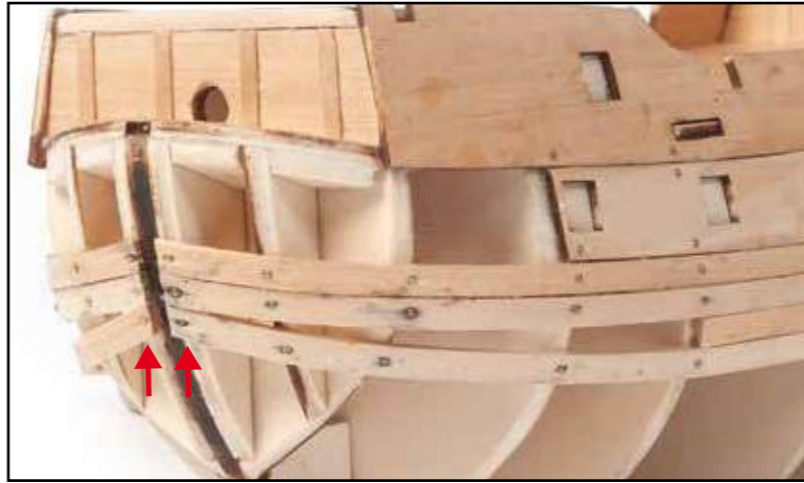
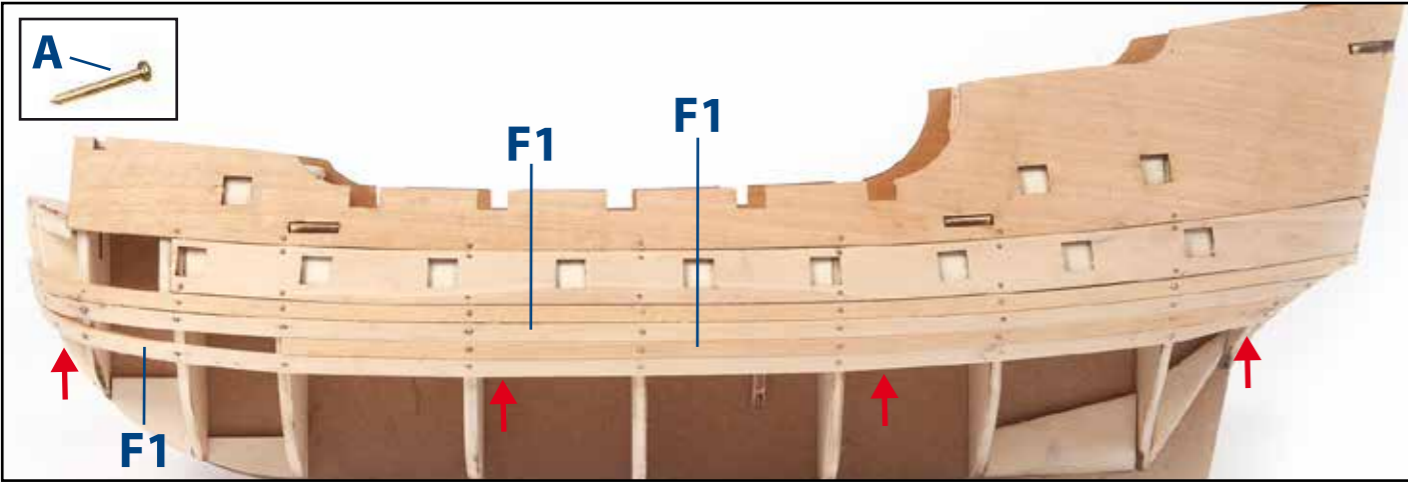
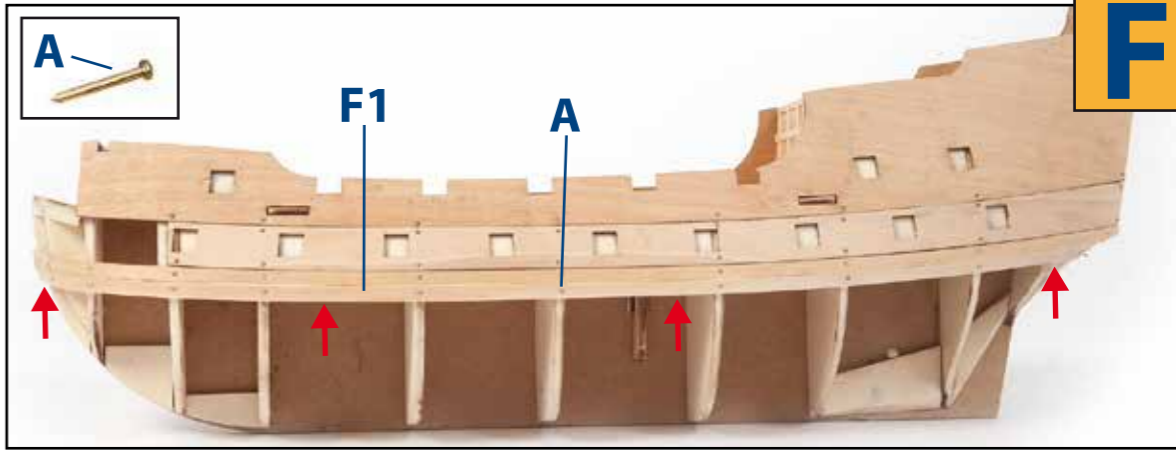
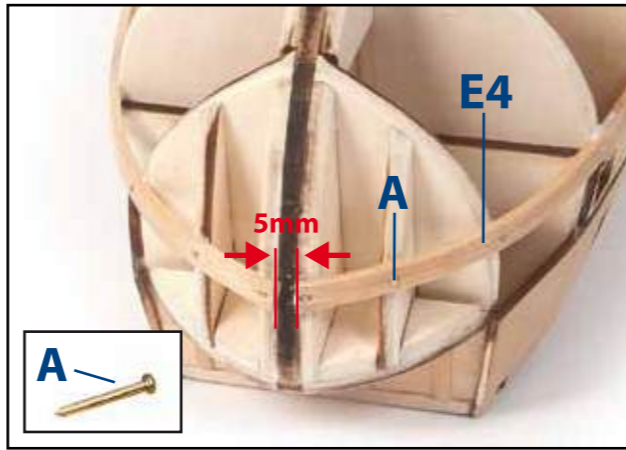

G

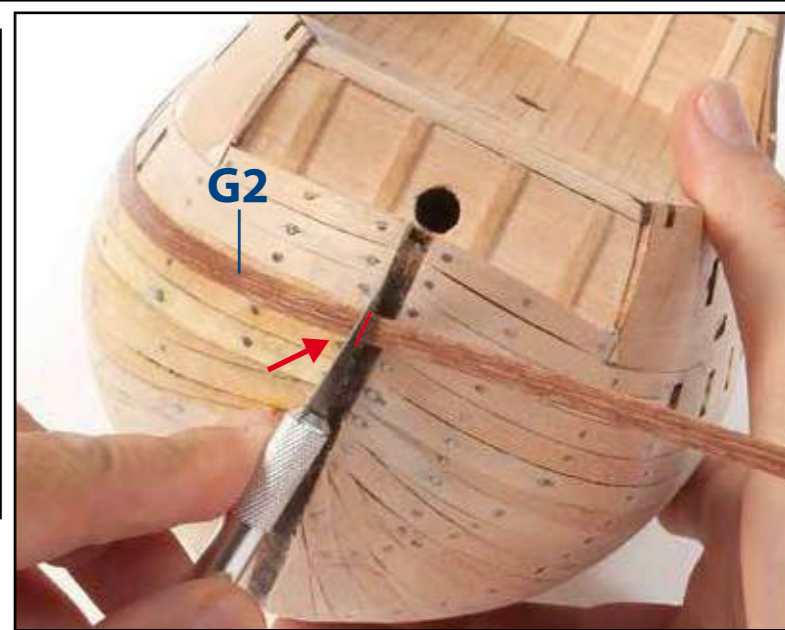
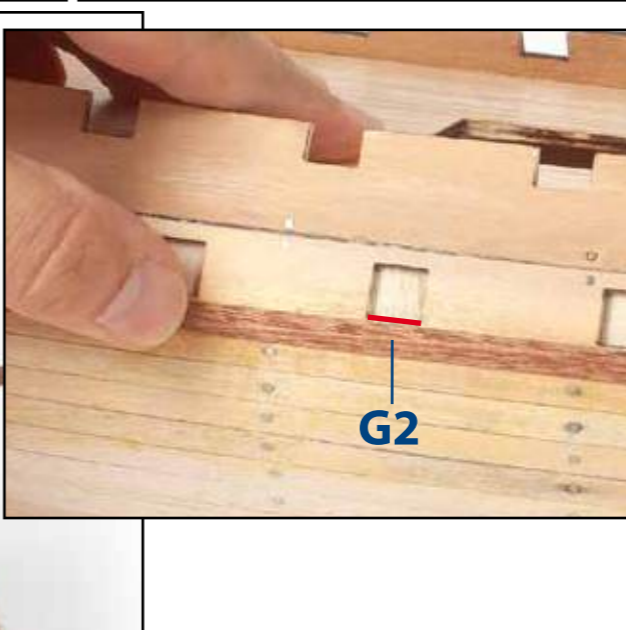
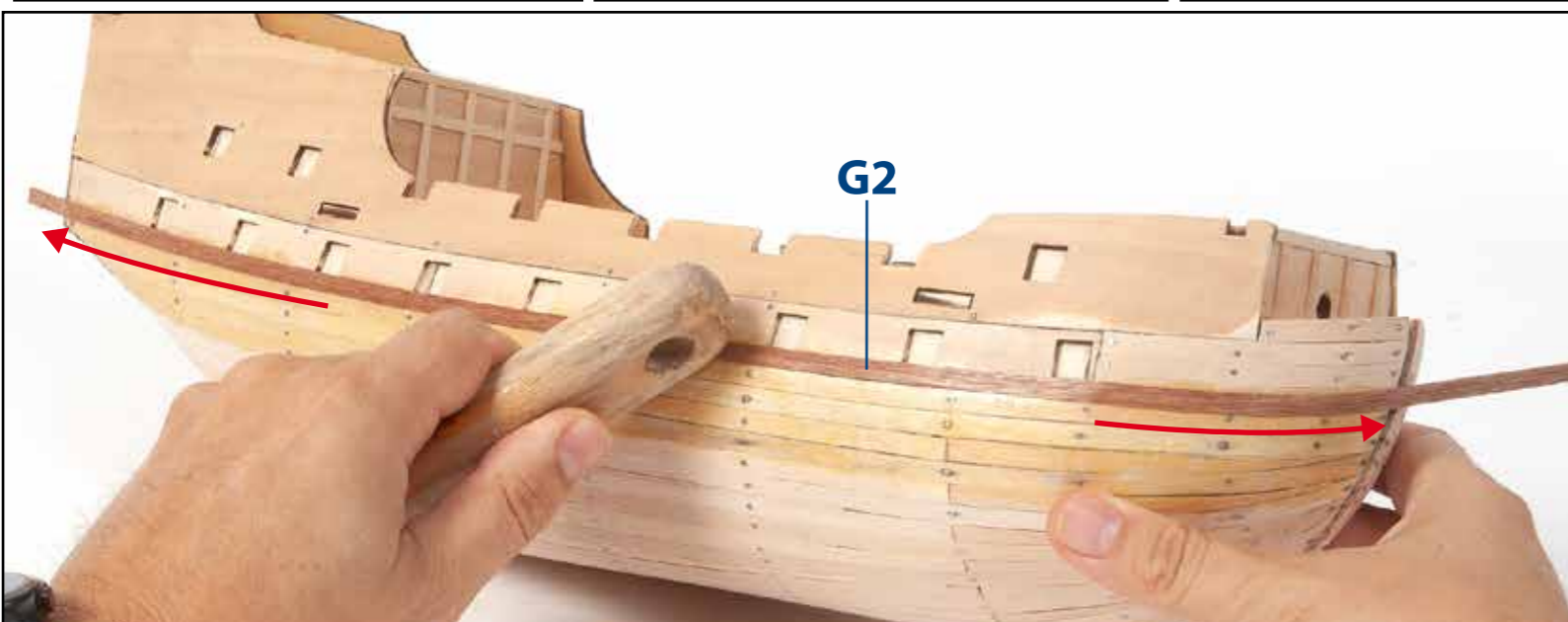
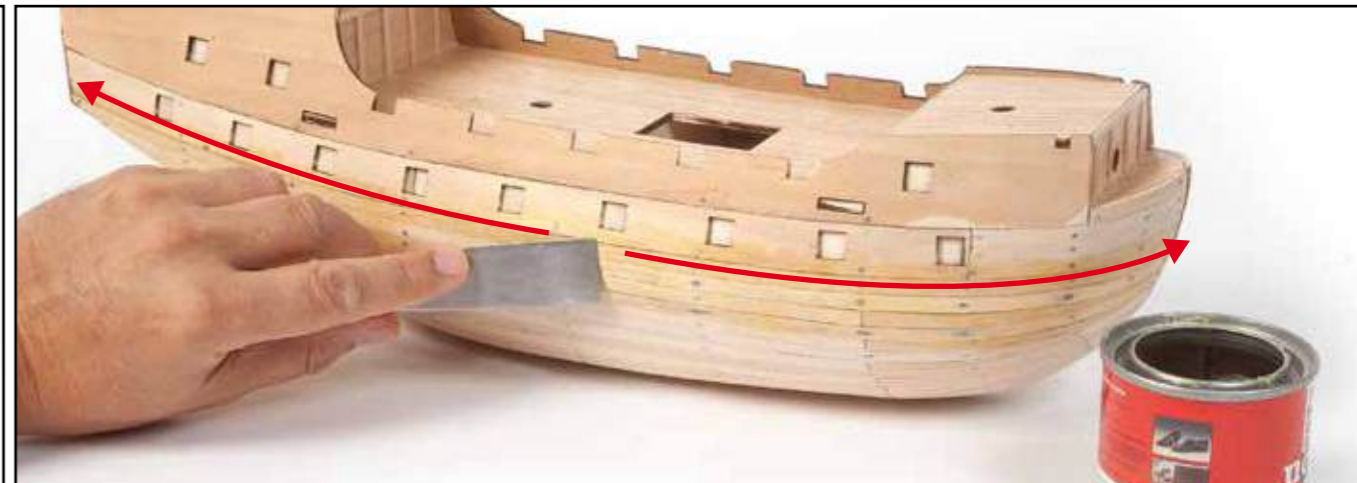
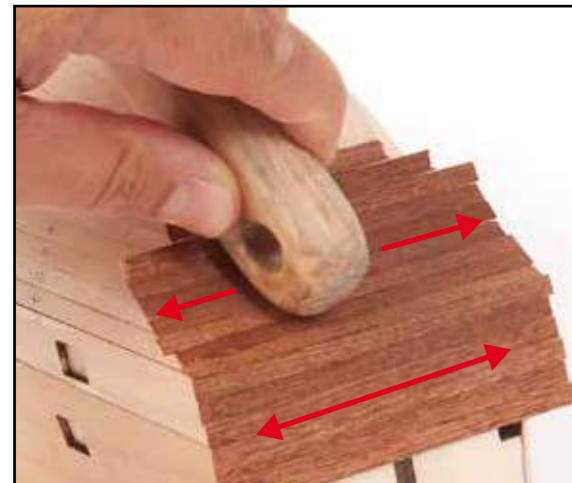
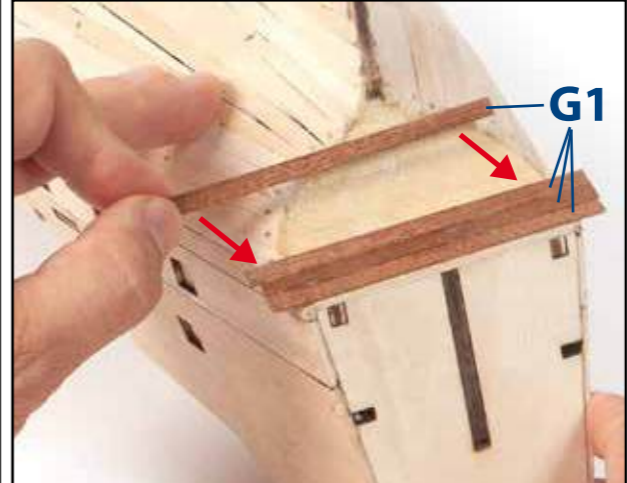
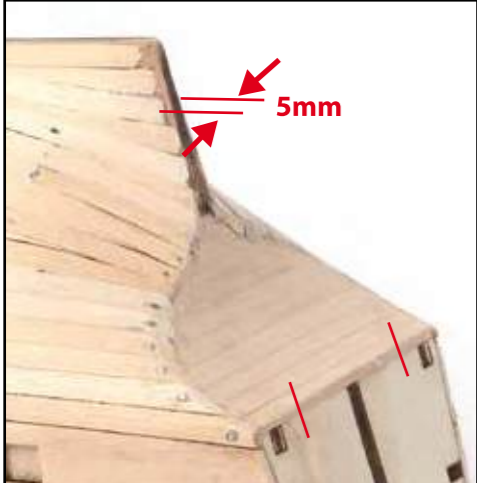
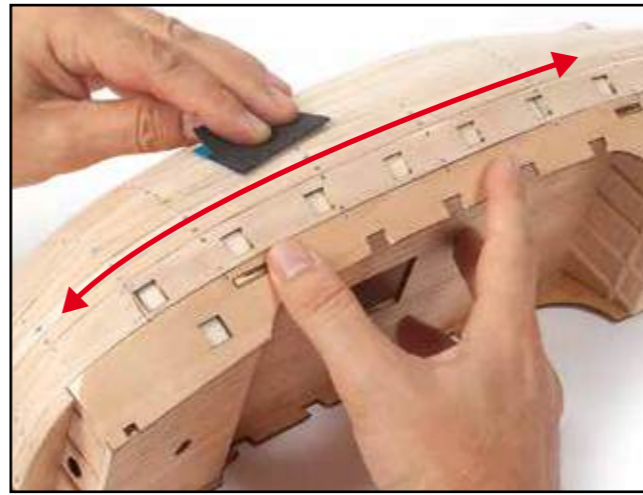
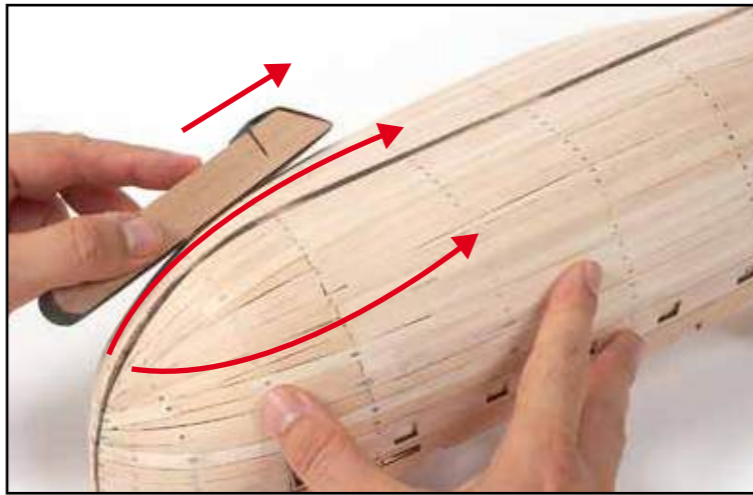

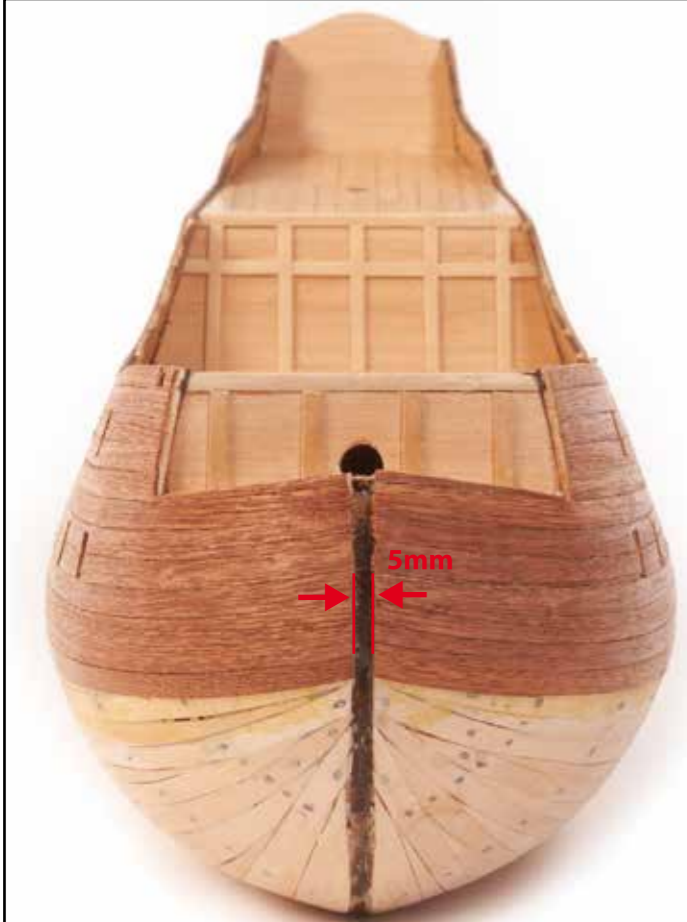
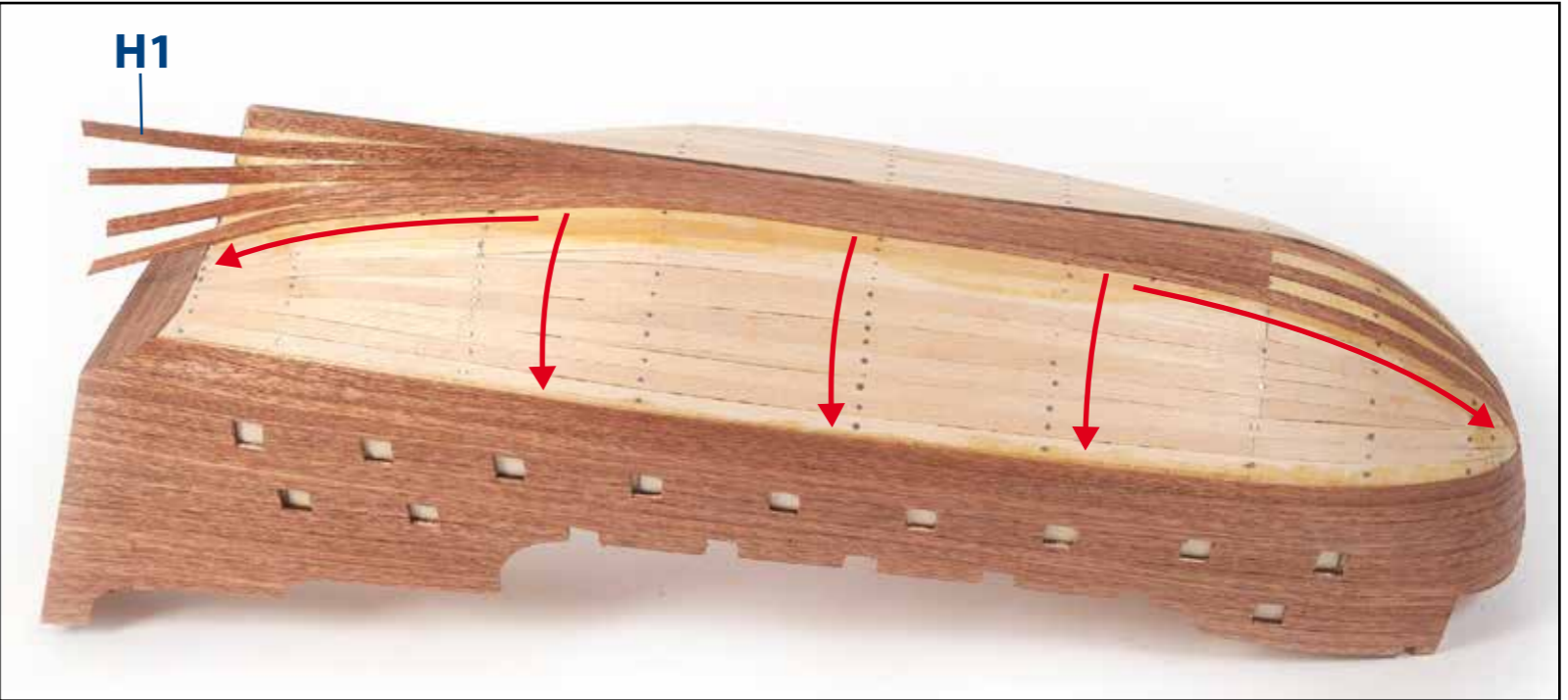
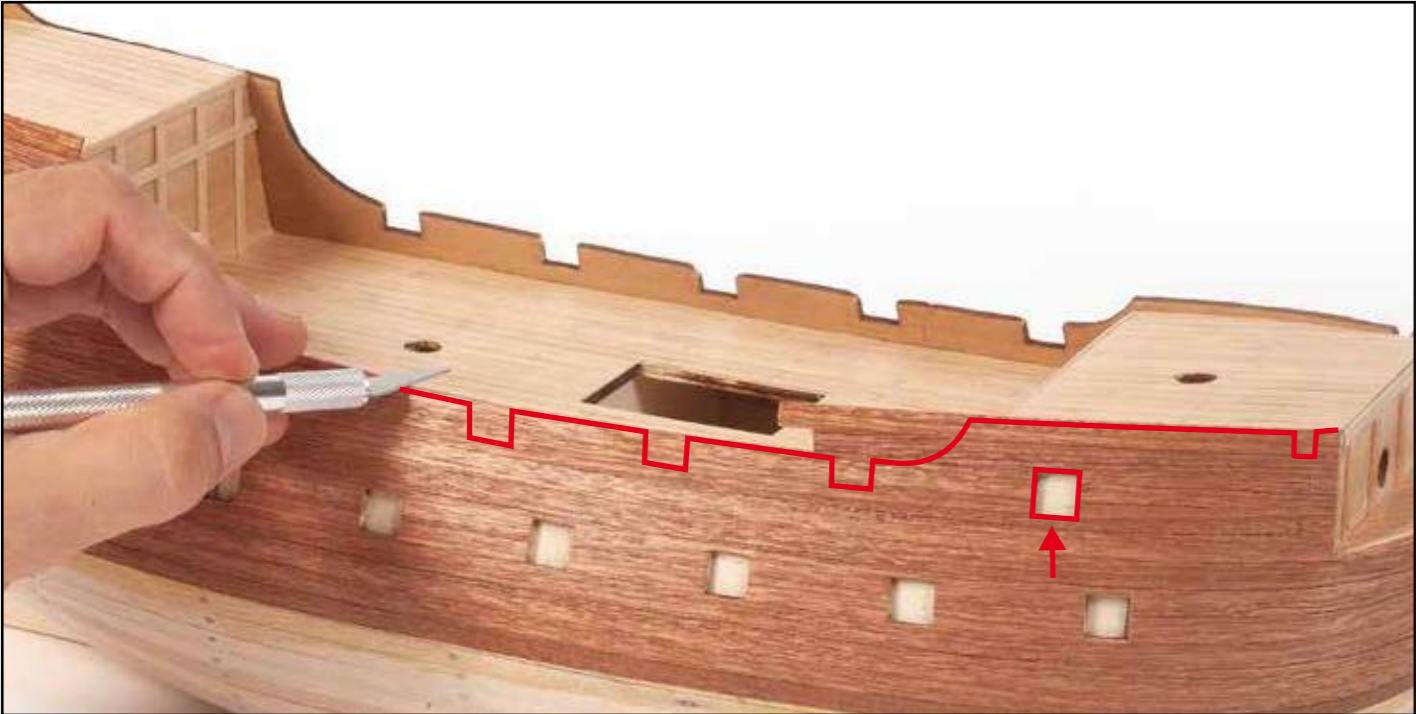
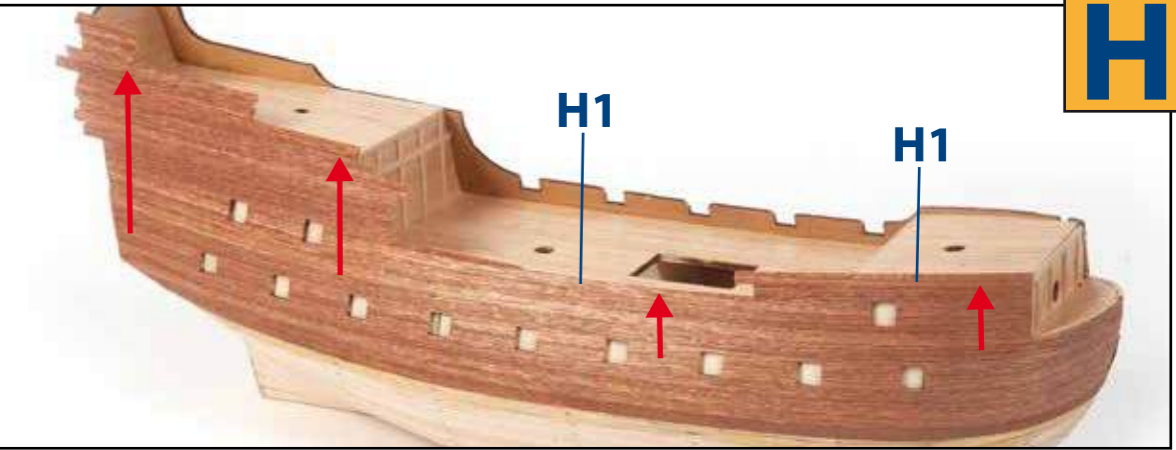
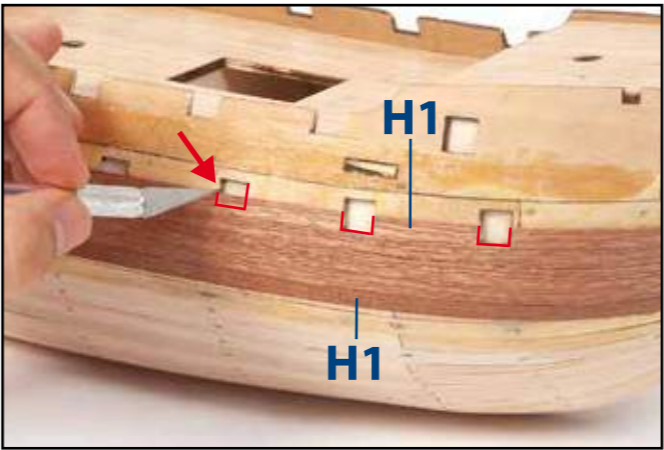
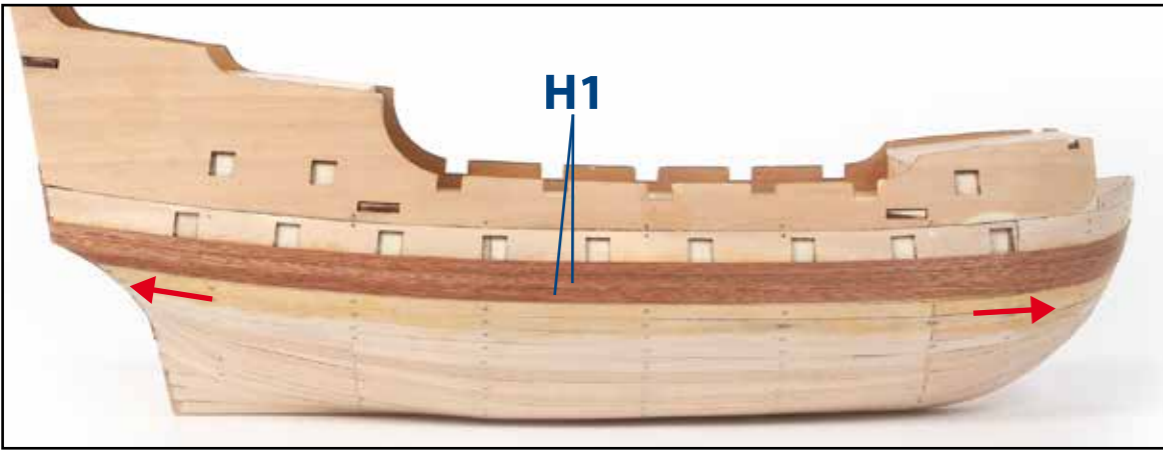

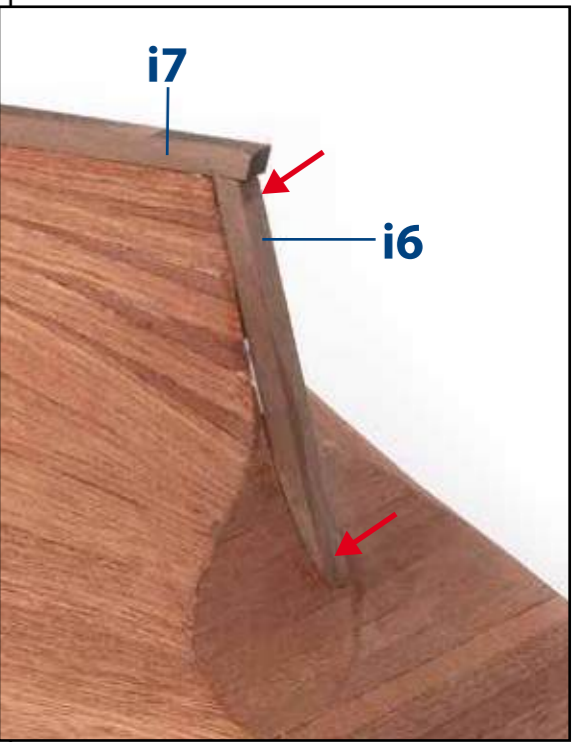
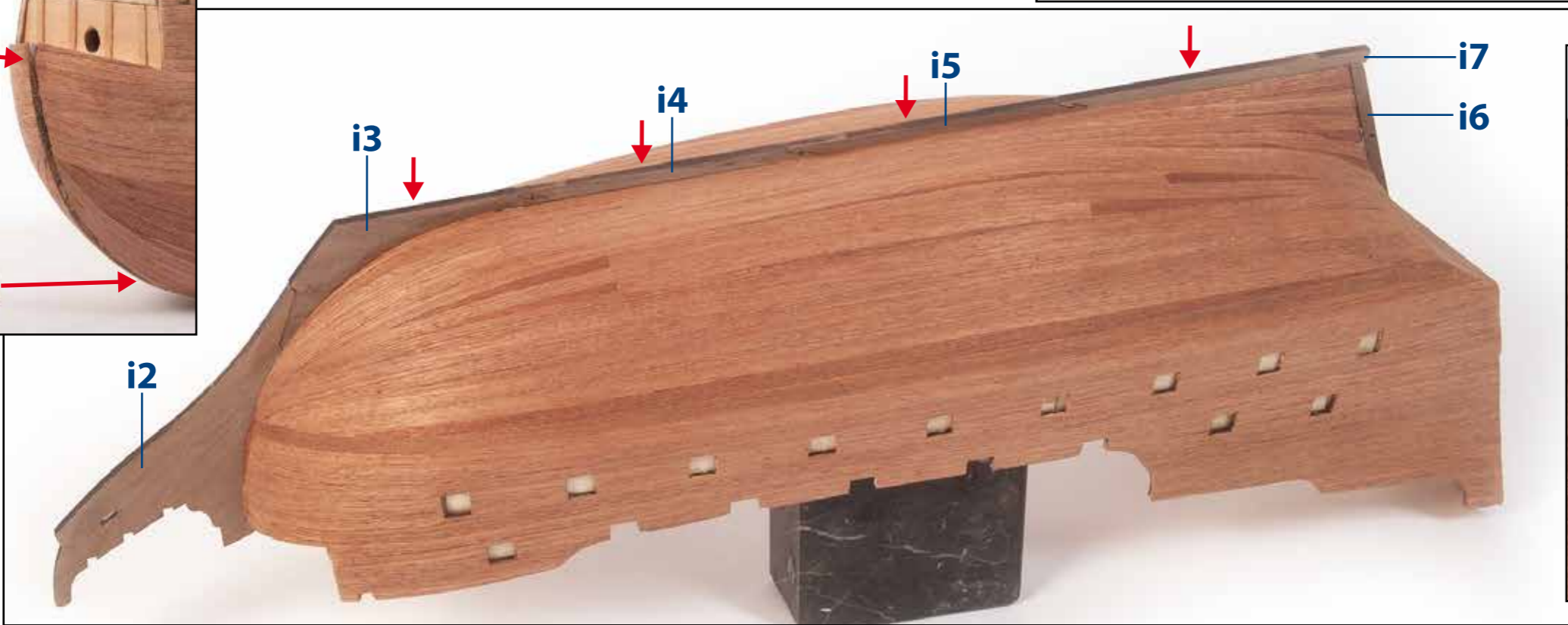
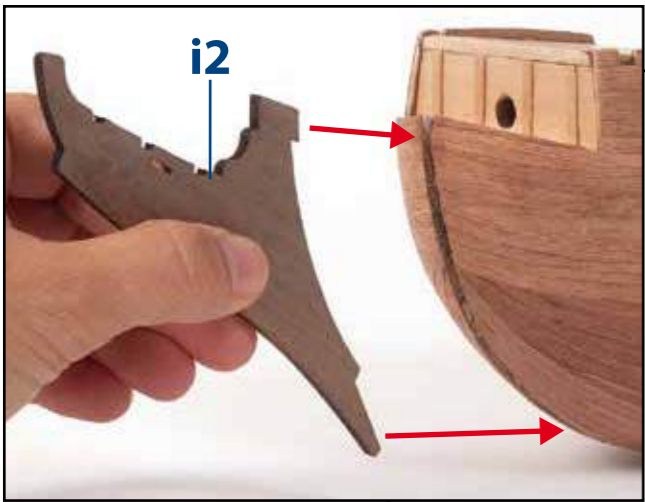
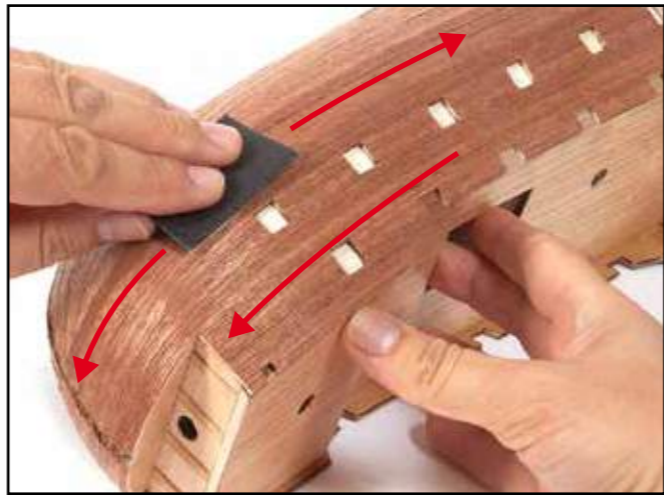
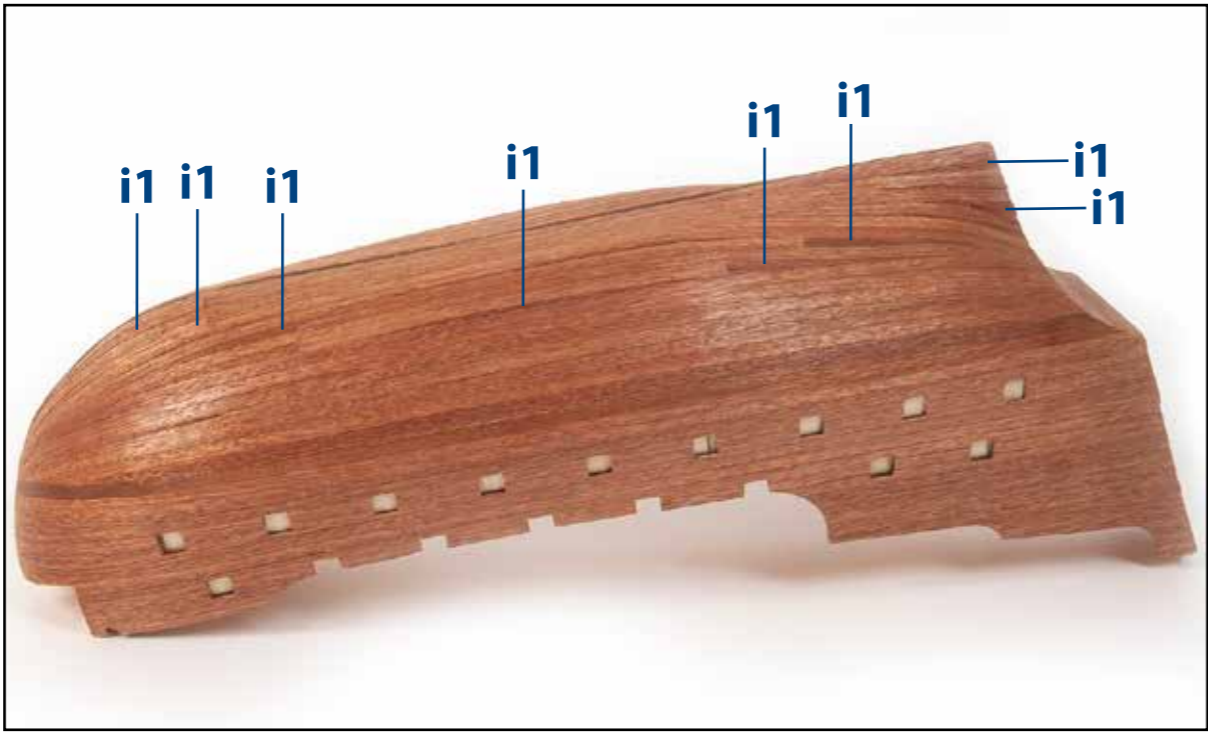
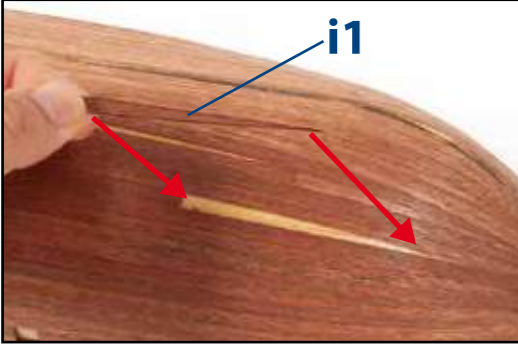

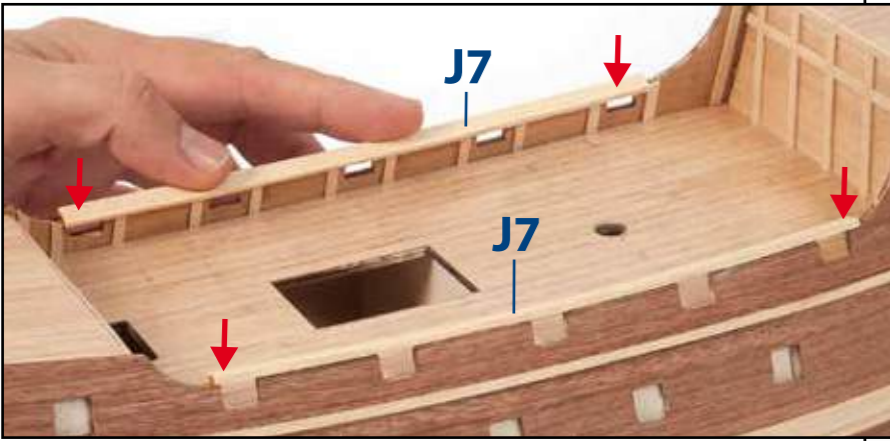
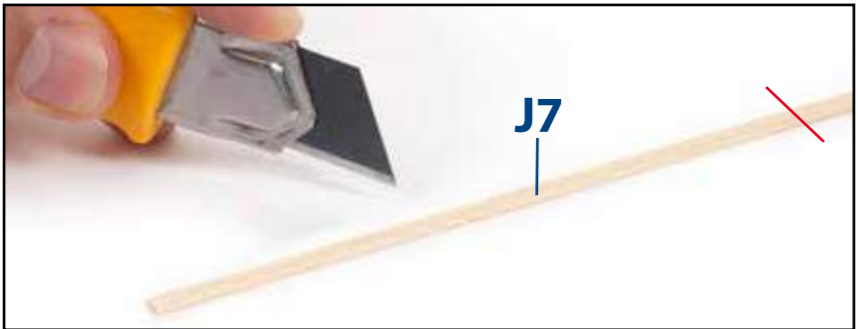
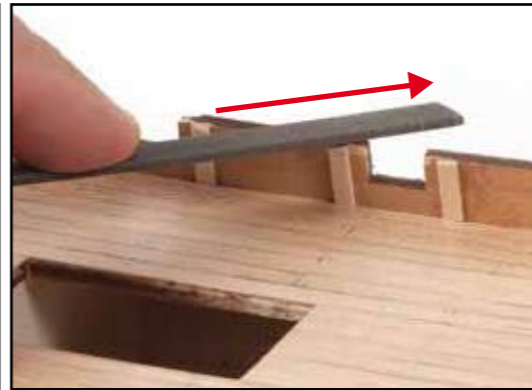
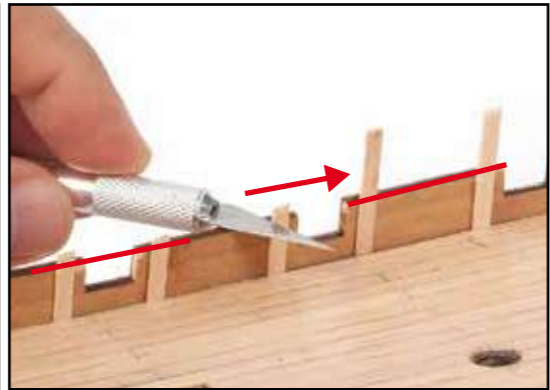
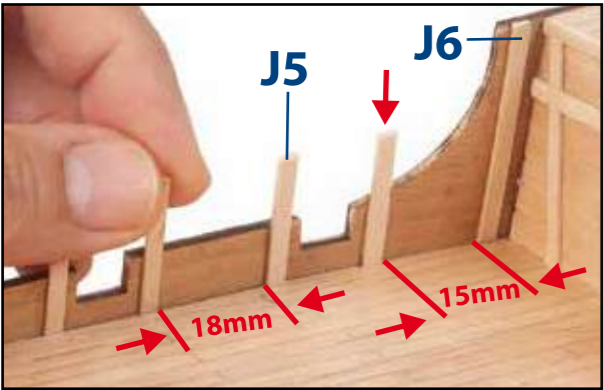
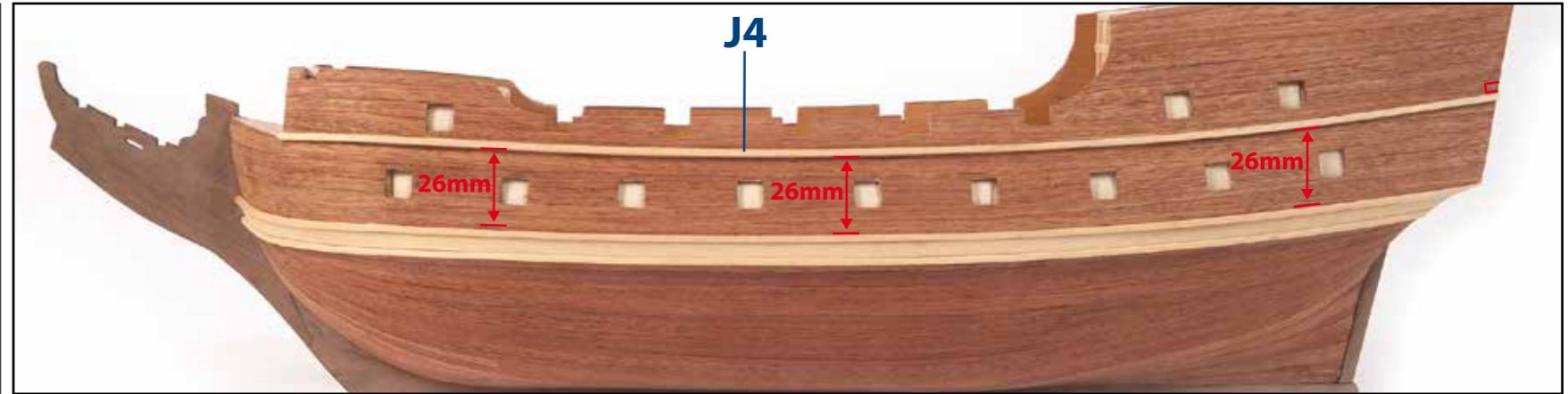
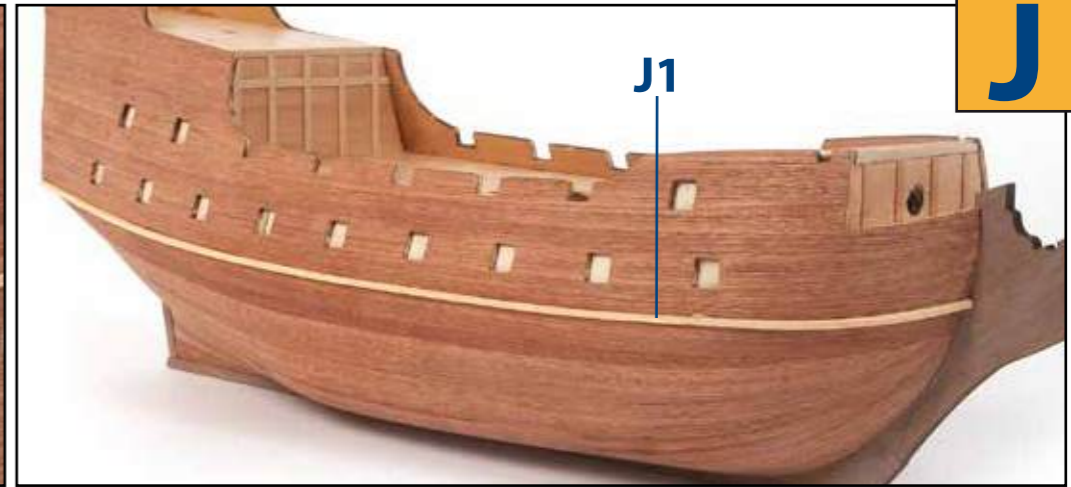
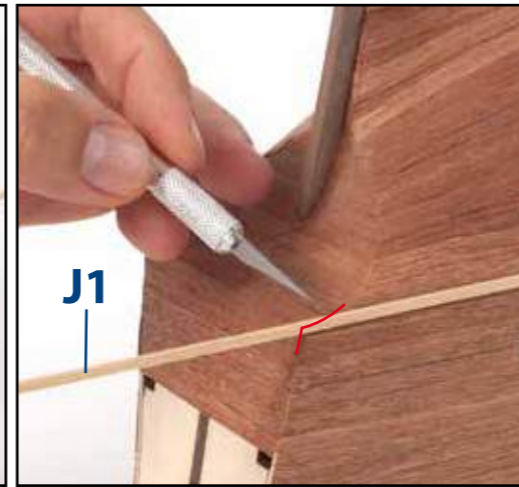
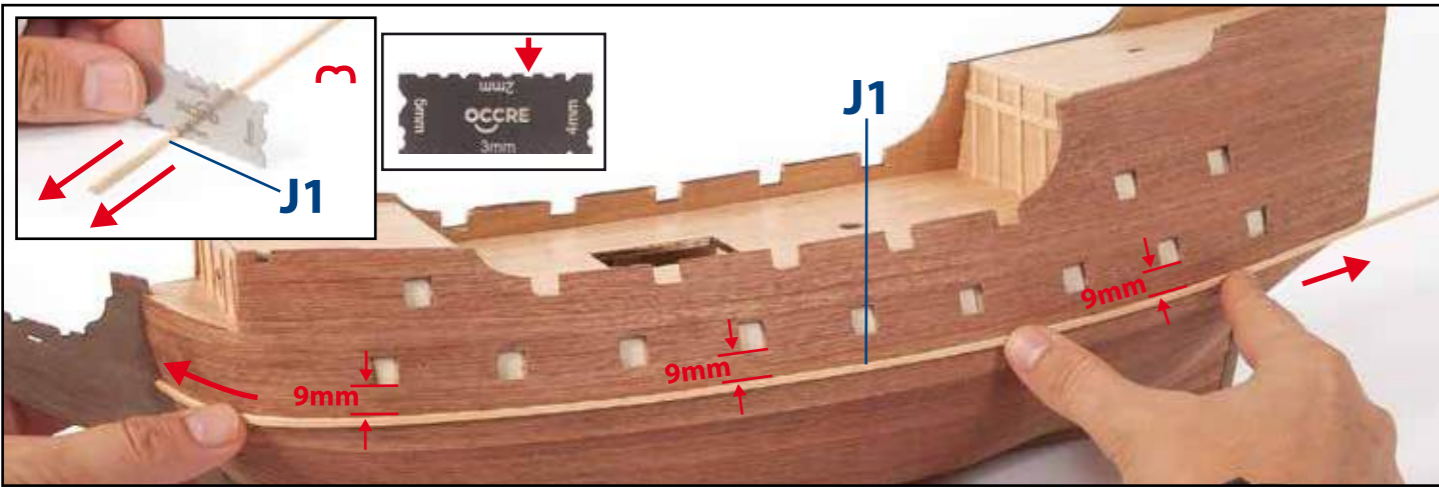

K

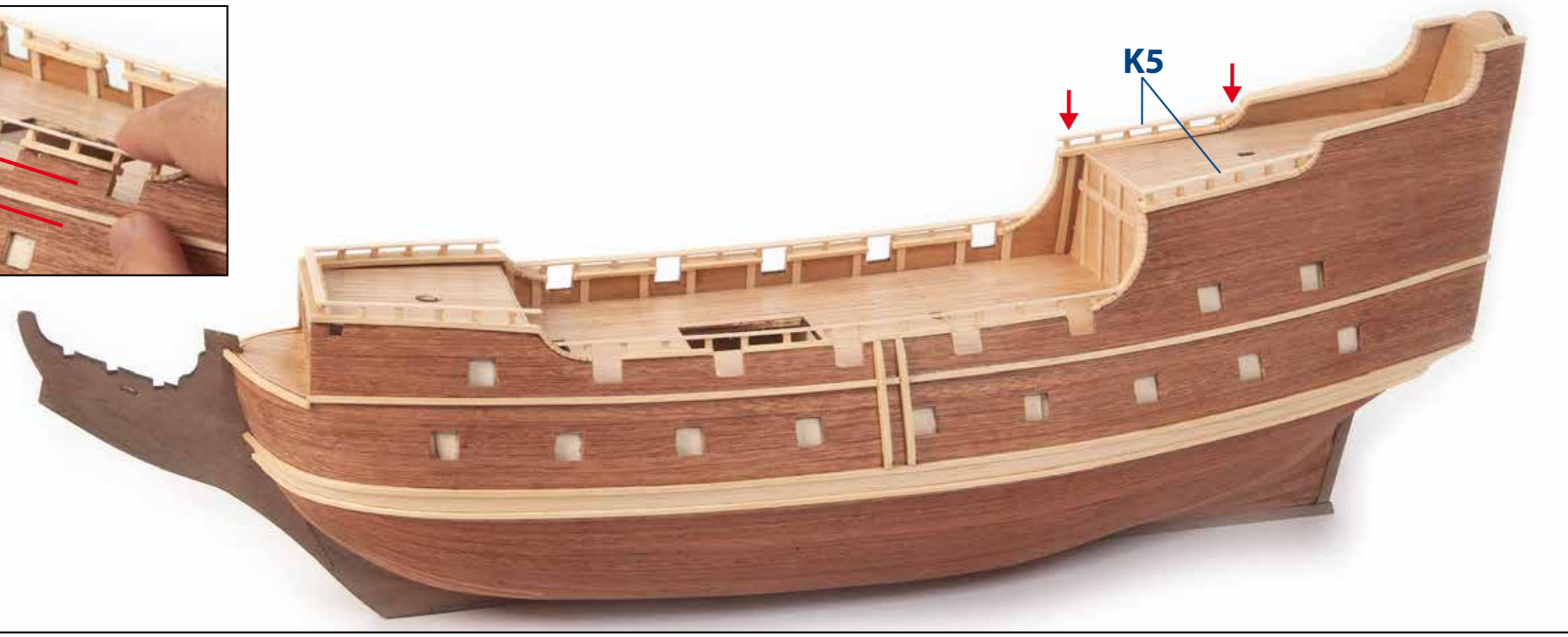
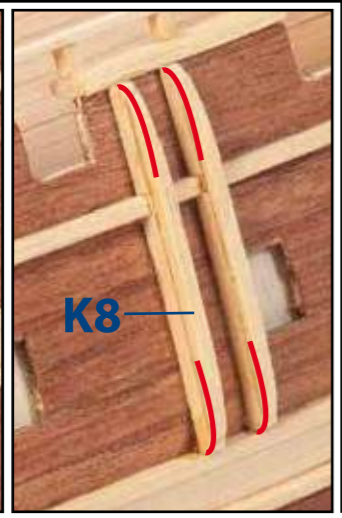
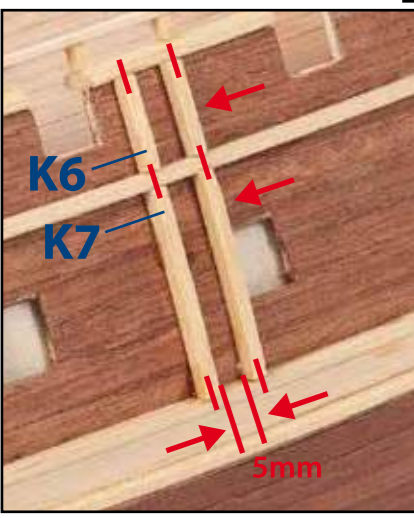
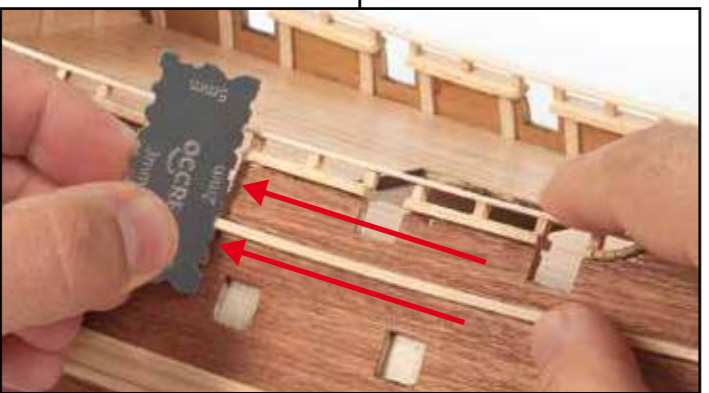
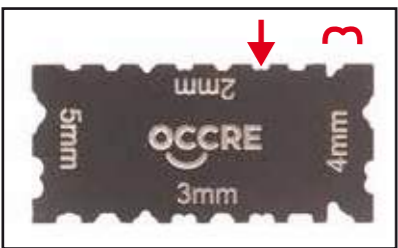
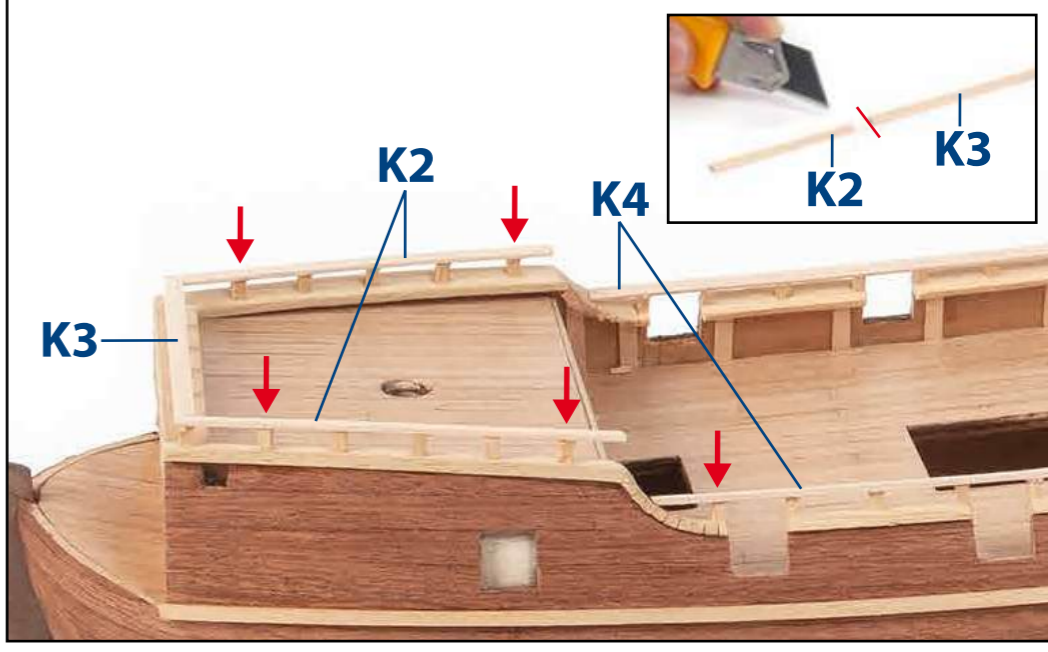
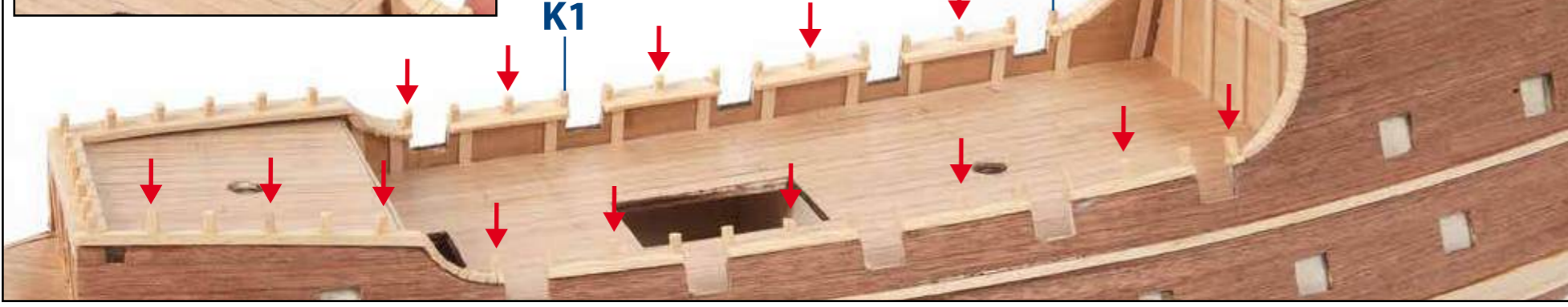
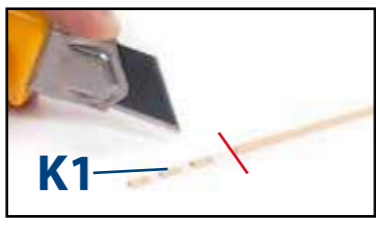
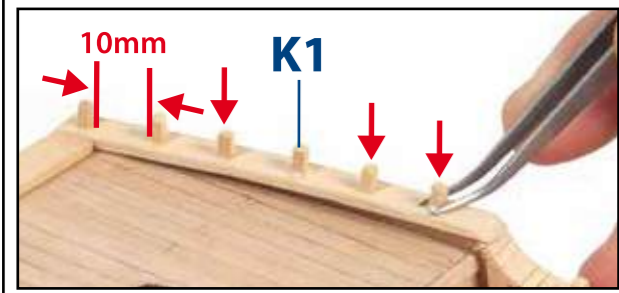
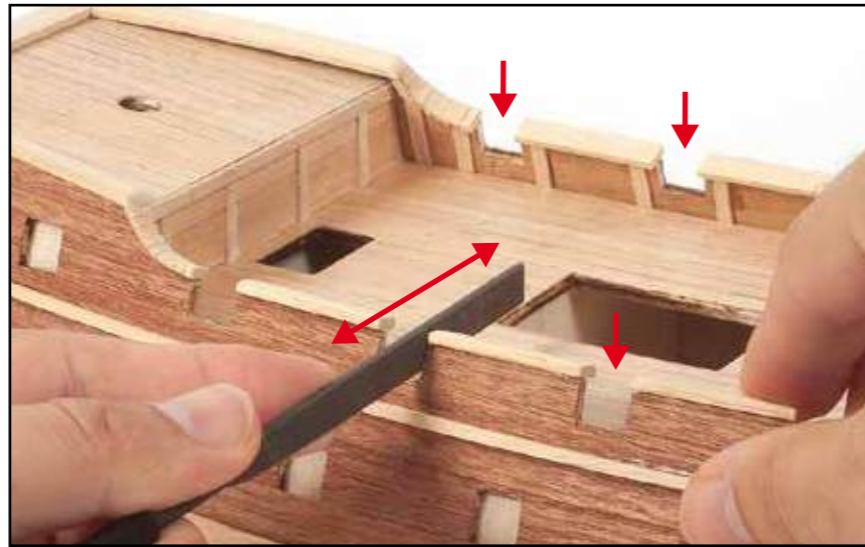
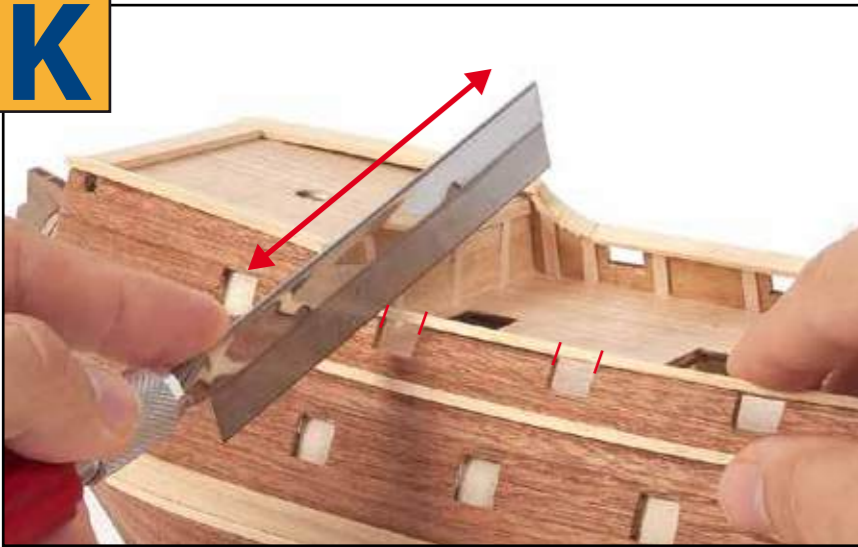

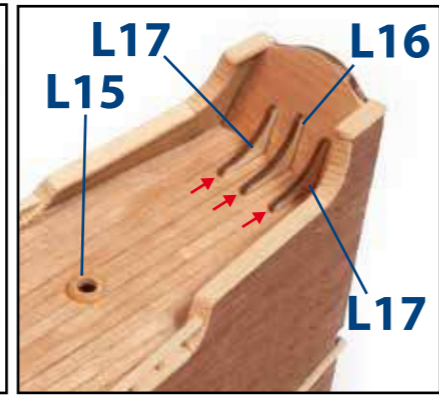
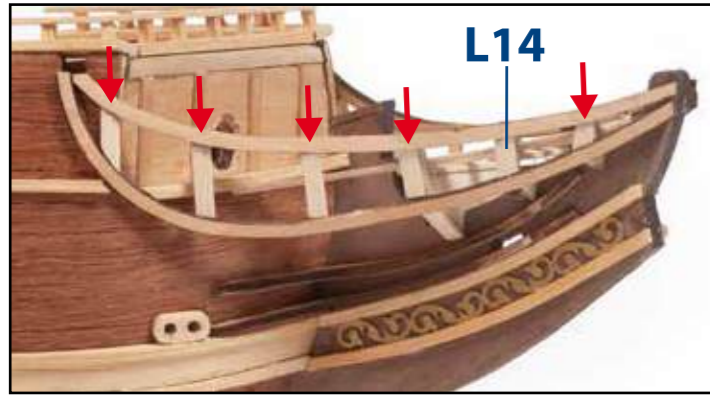
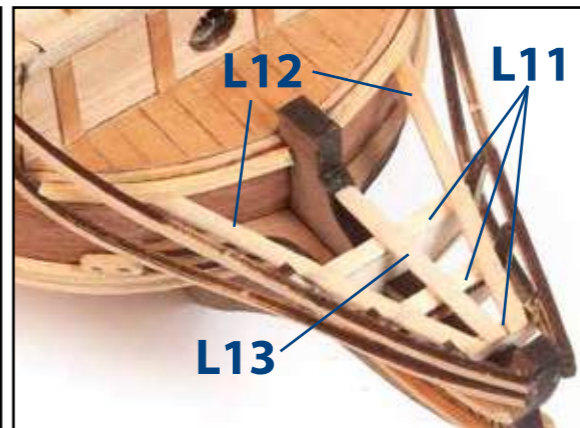
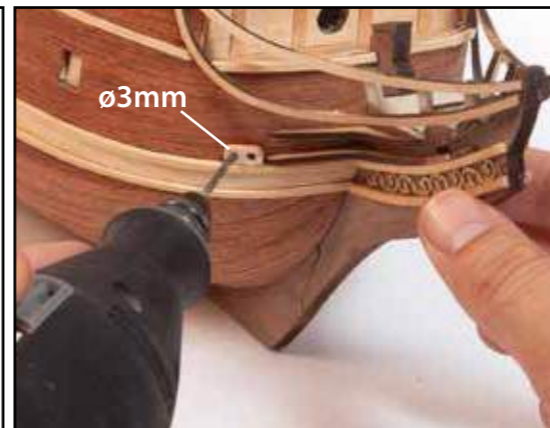
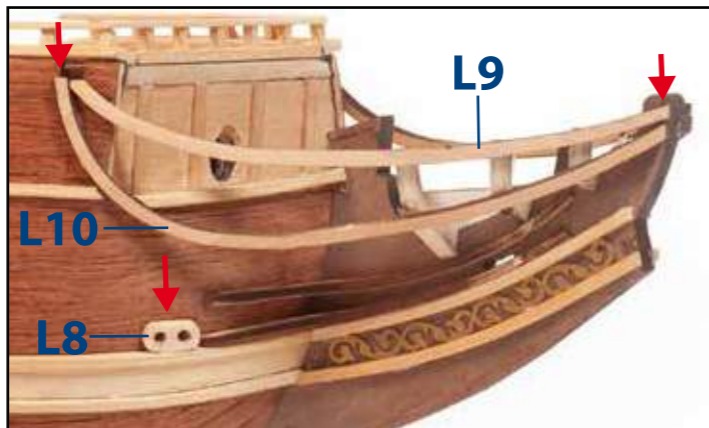
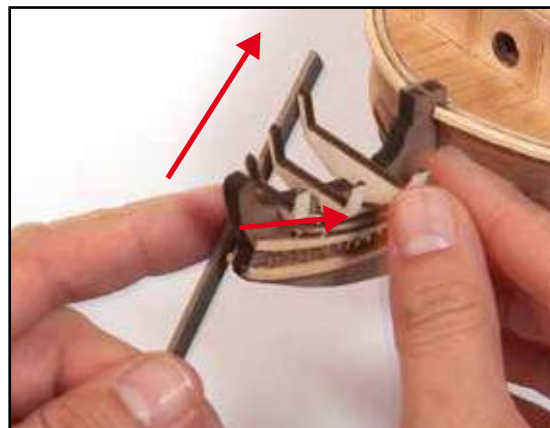
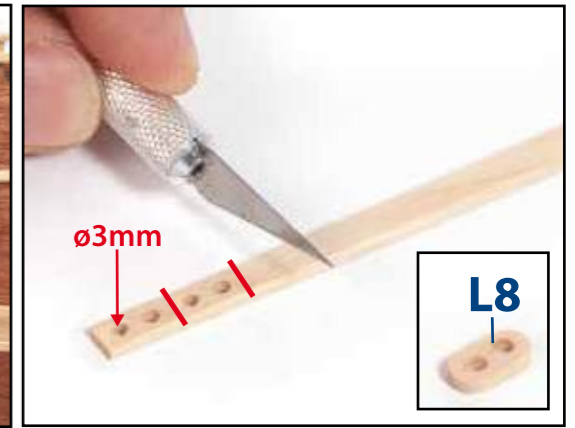
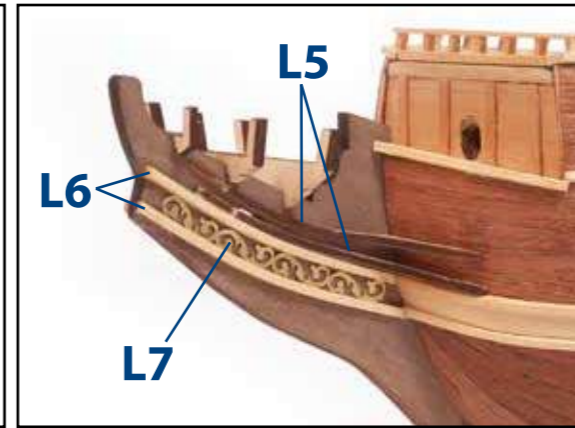
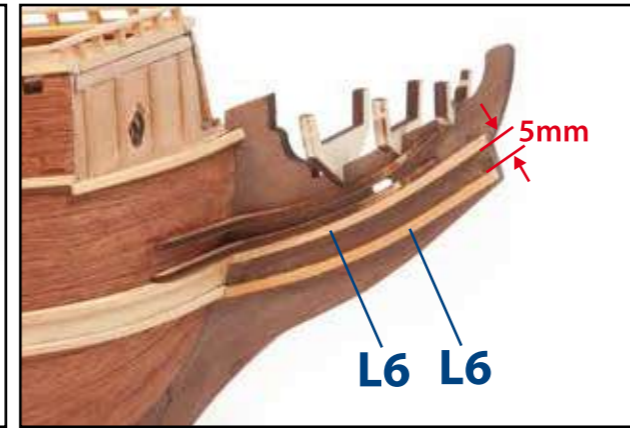
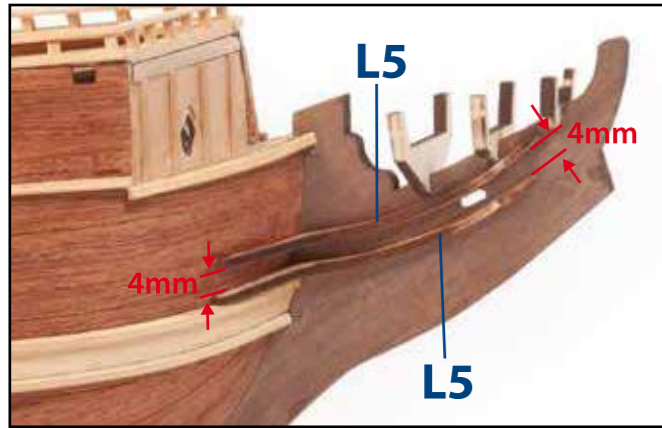
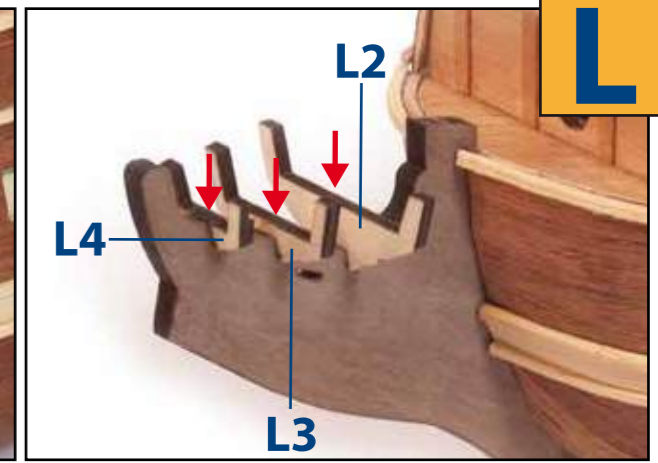
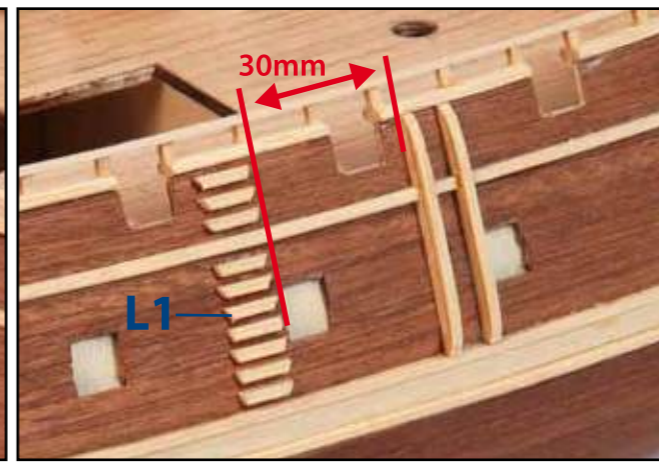
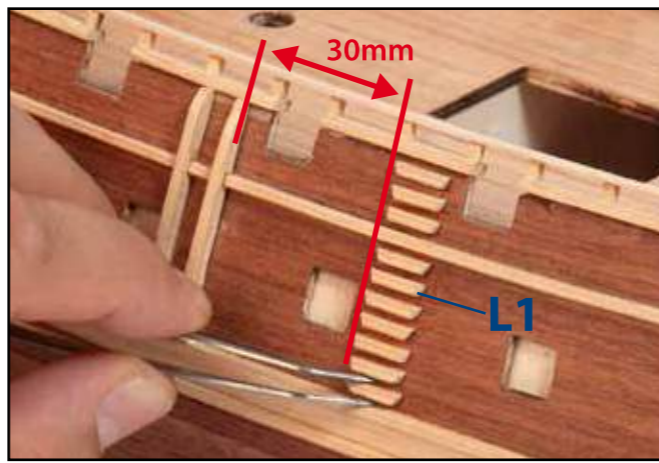
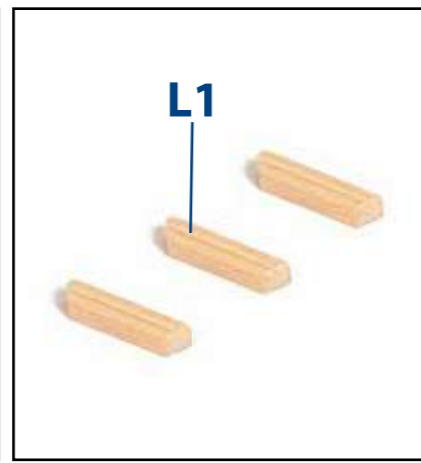
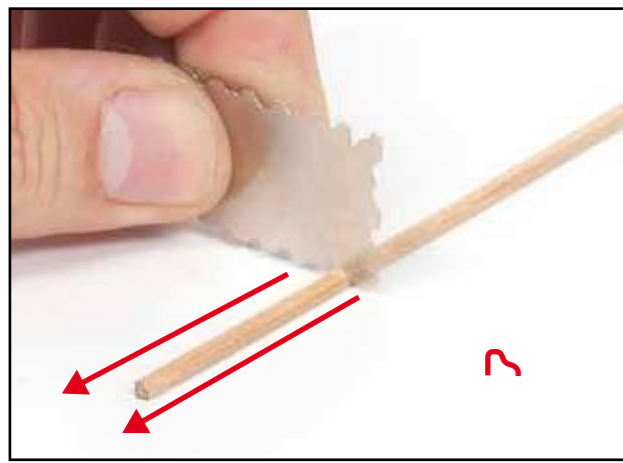

M

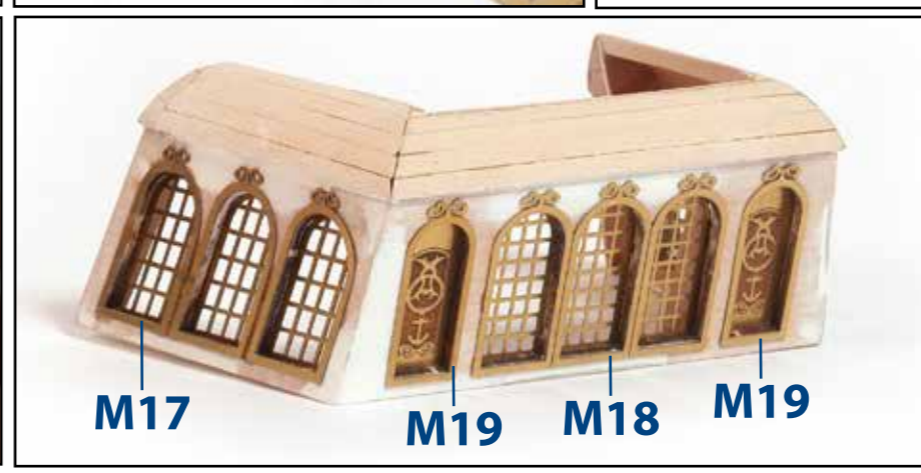
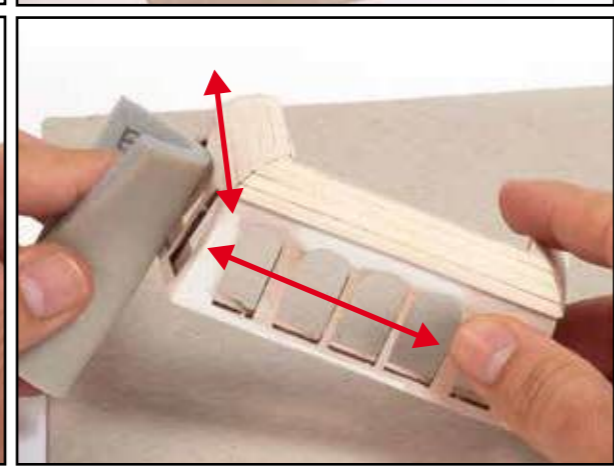
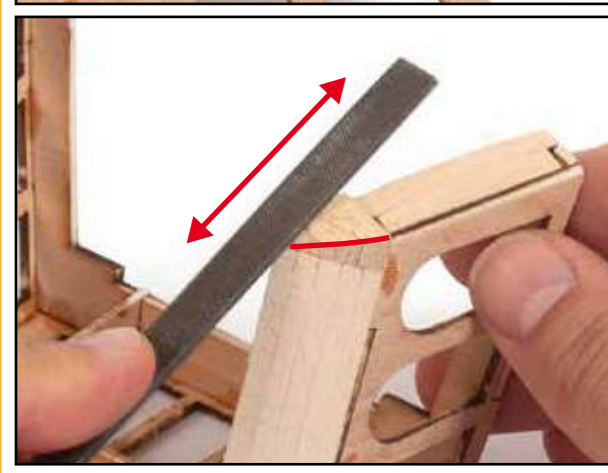
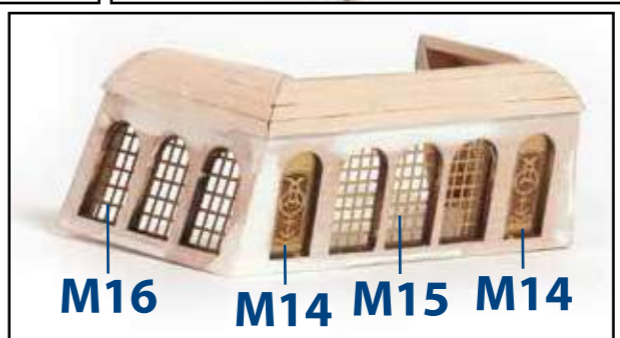
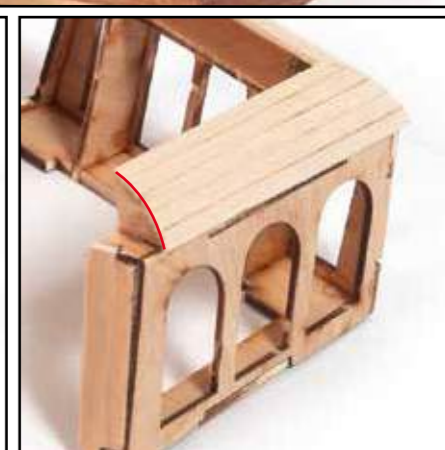
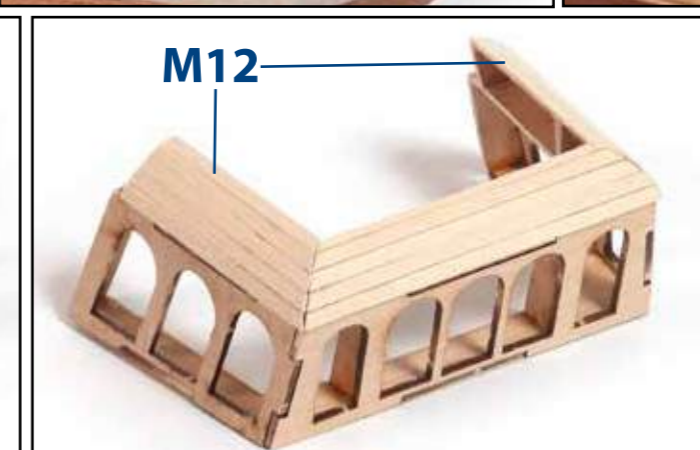
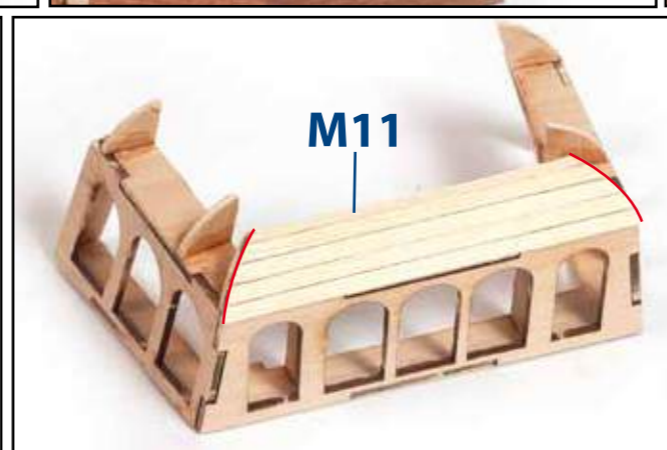
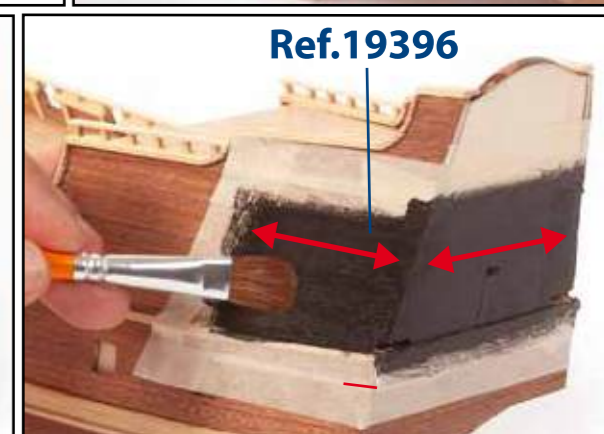
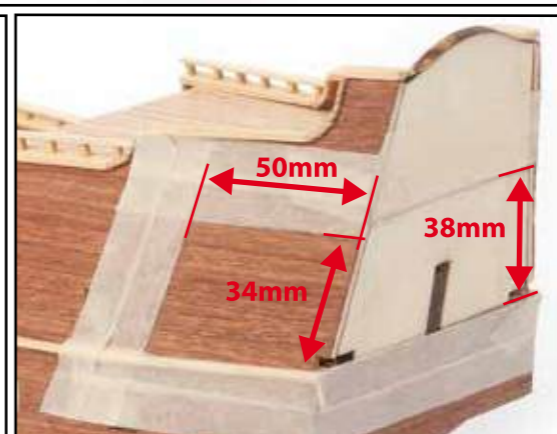
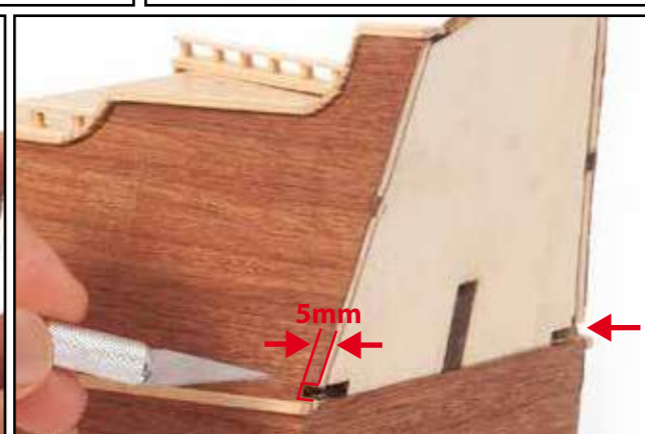
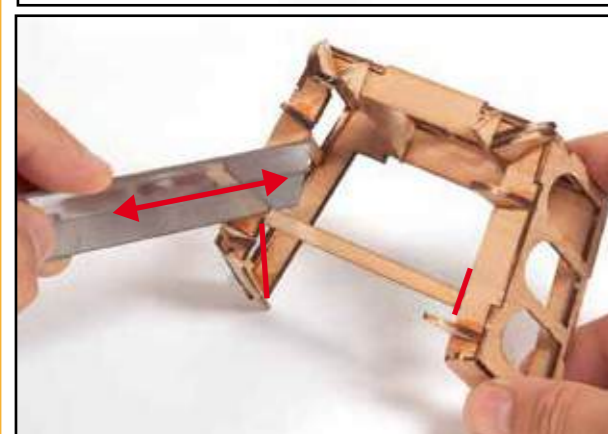
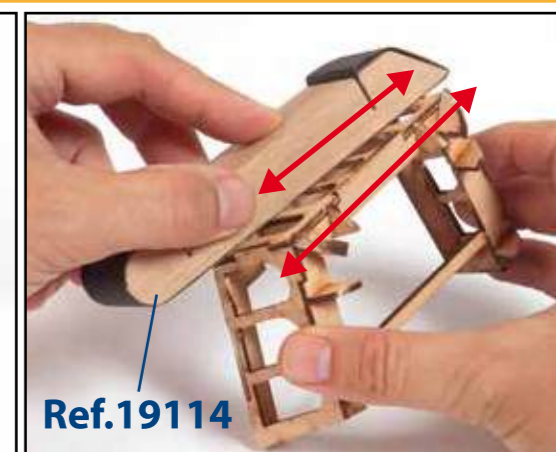
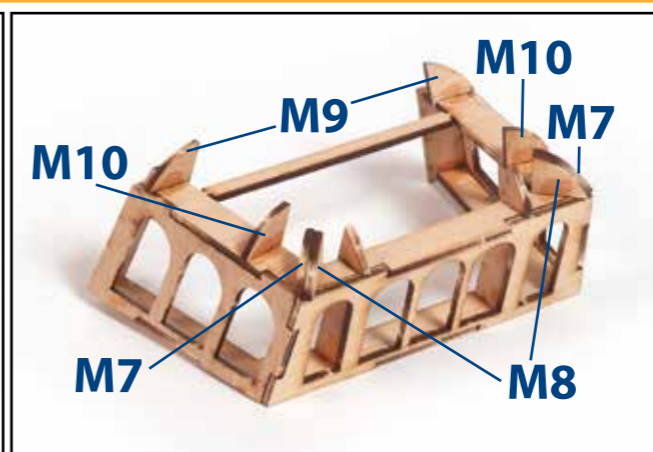
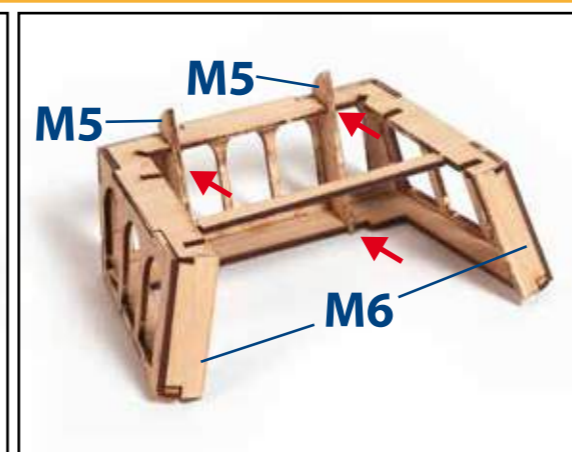
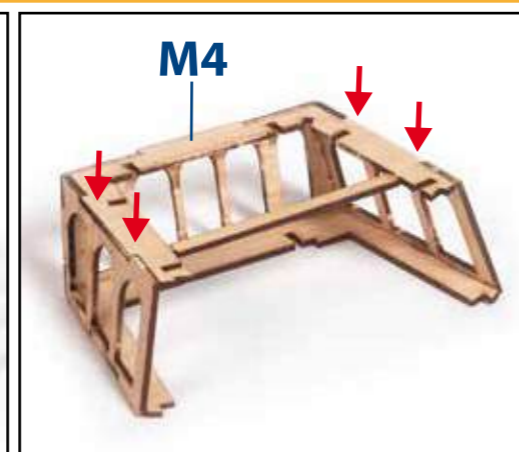
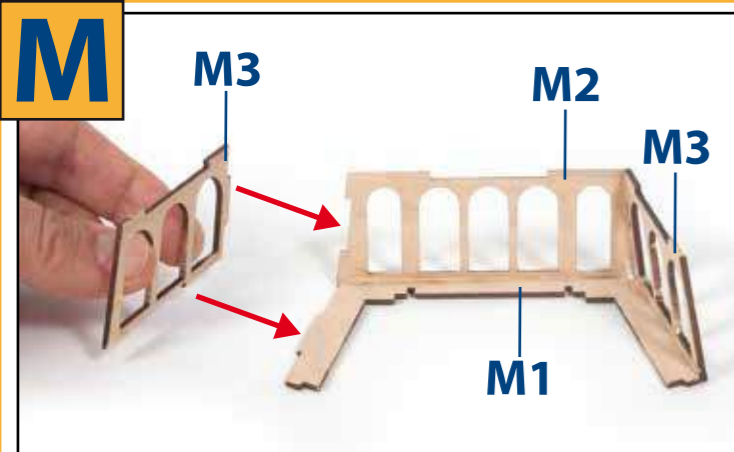

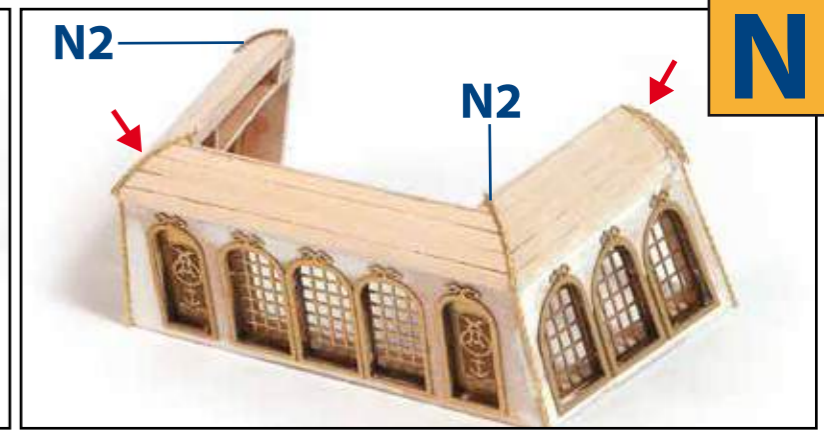
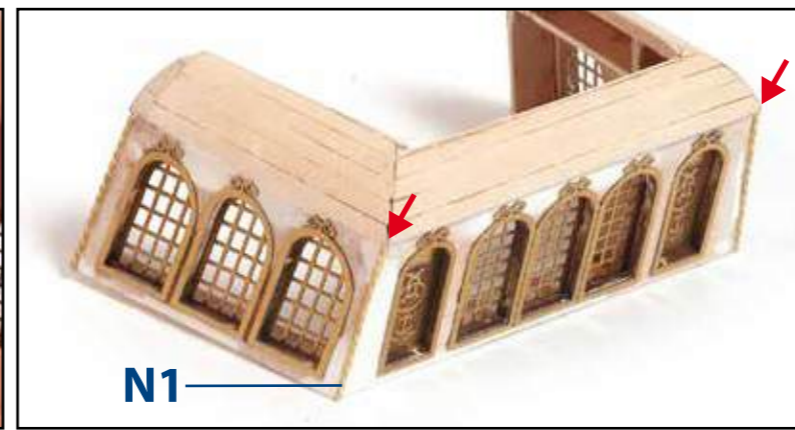
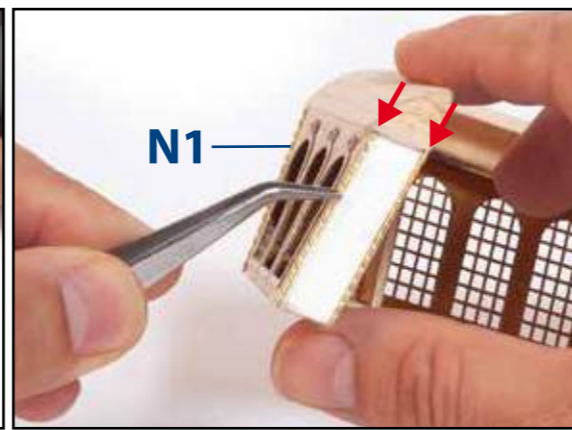
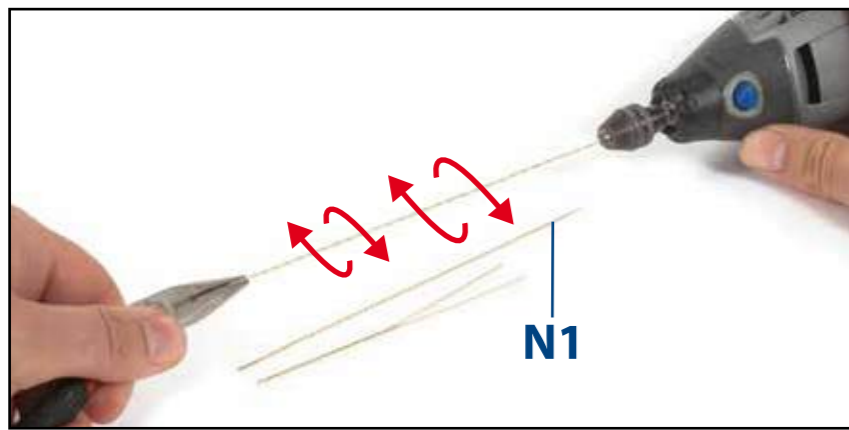

N

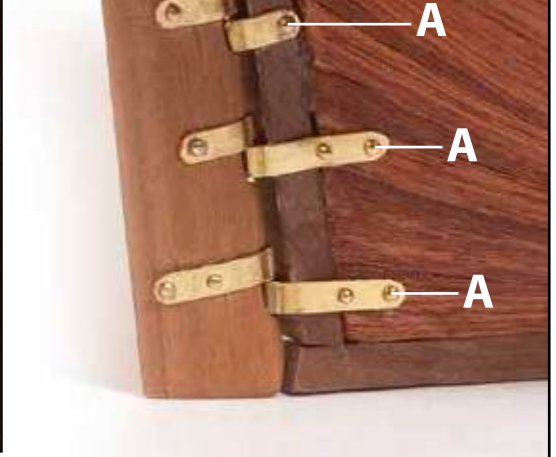
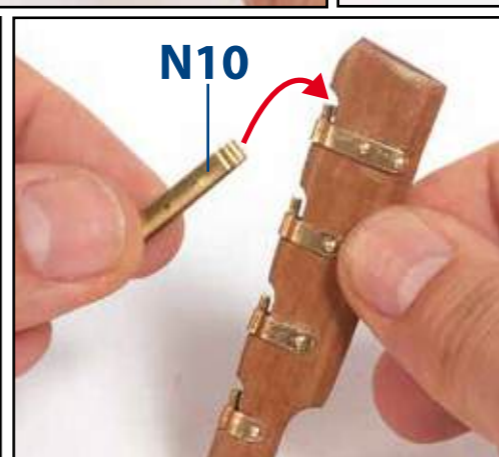
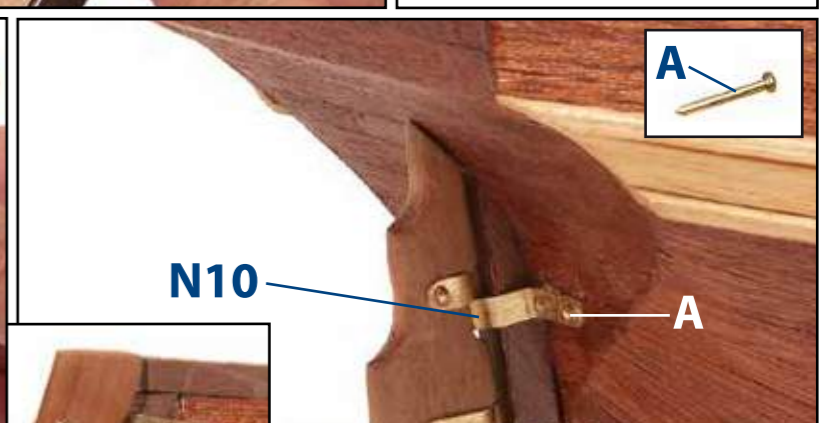
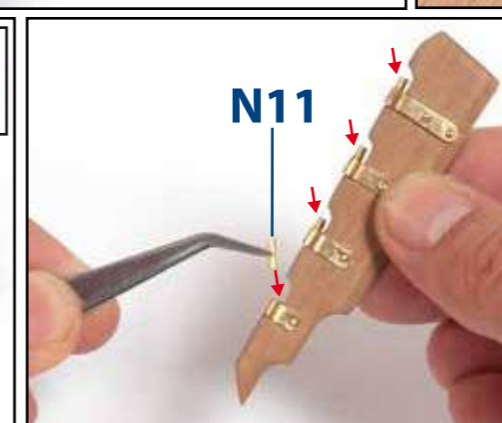
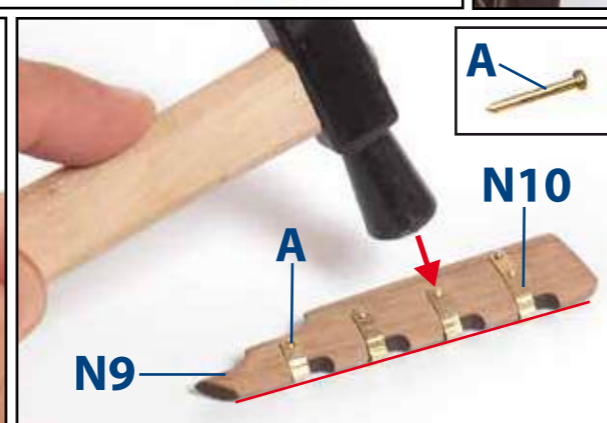
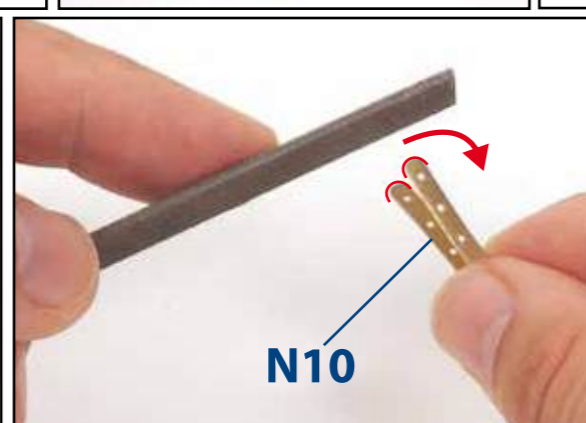
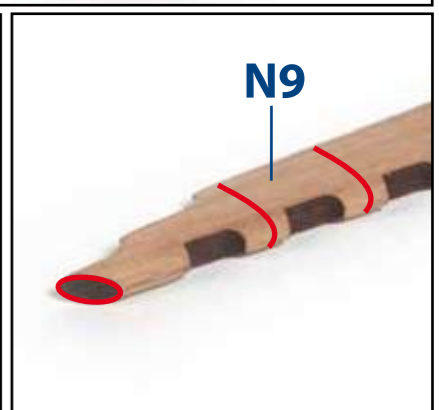
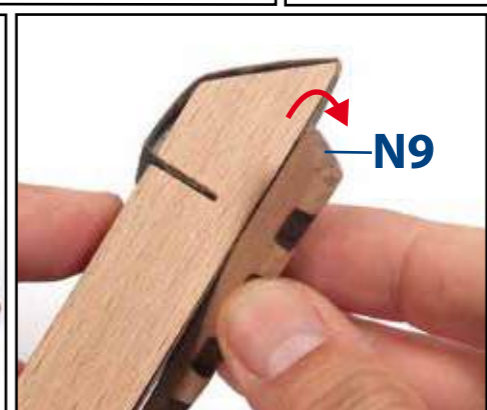
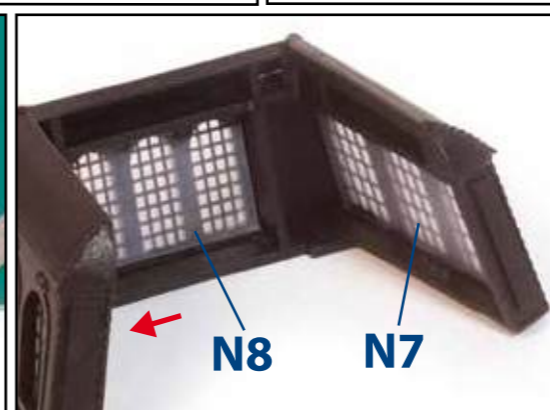
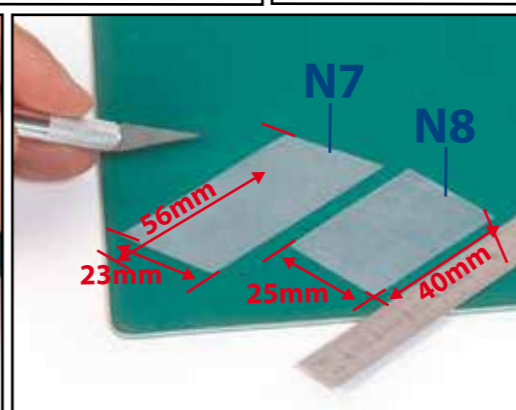
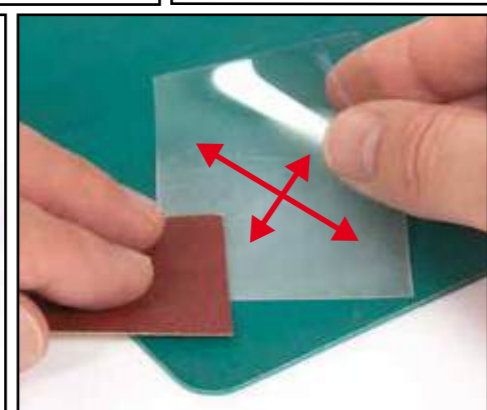
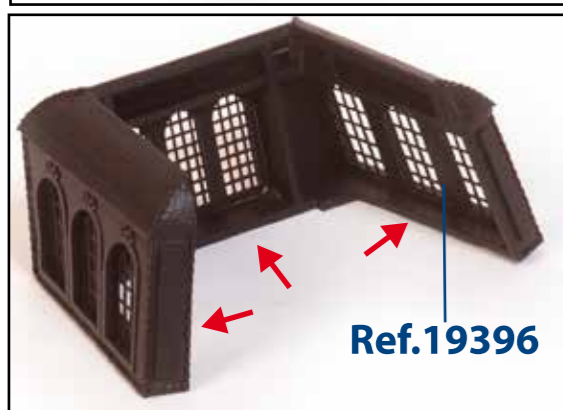
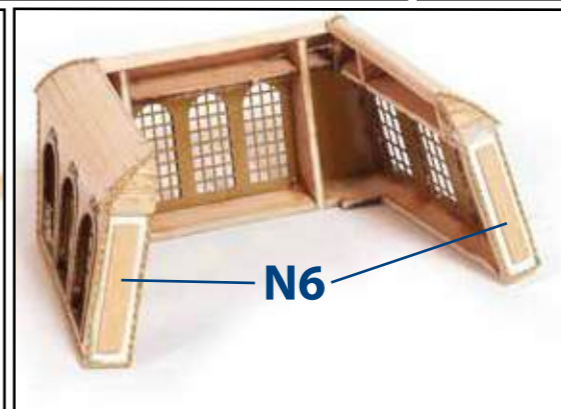
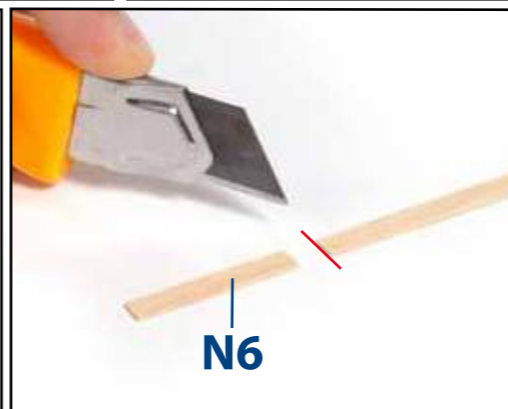
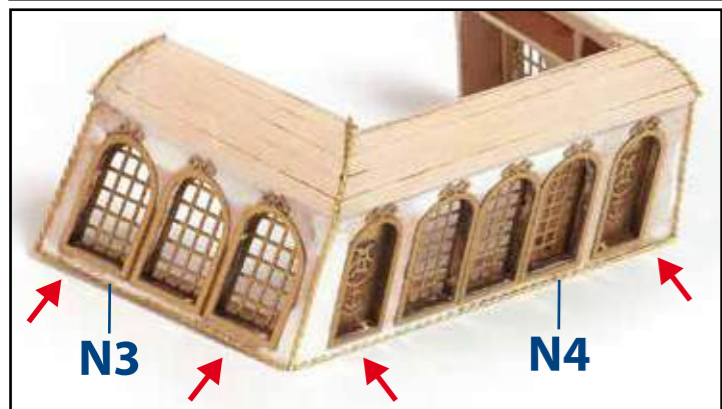

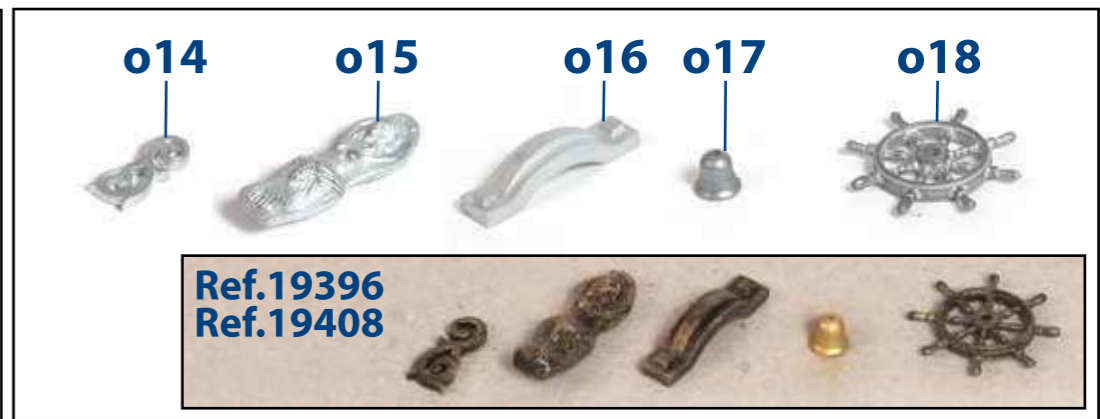
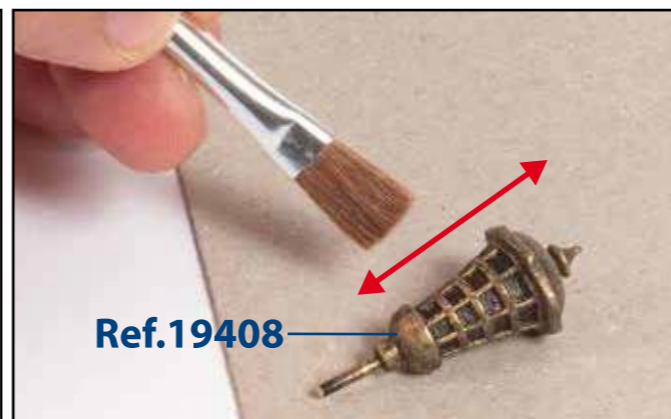
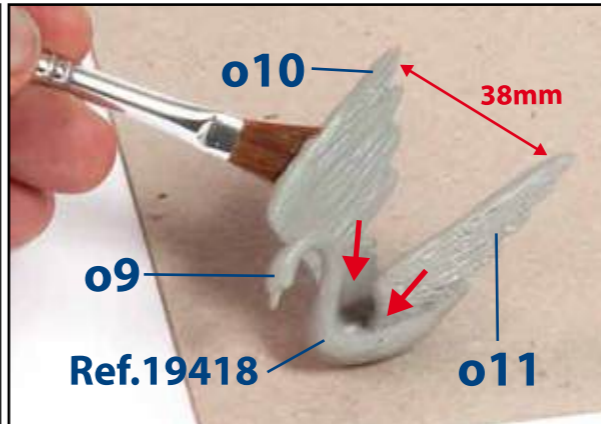
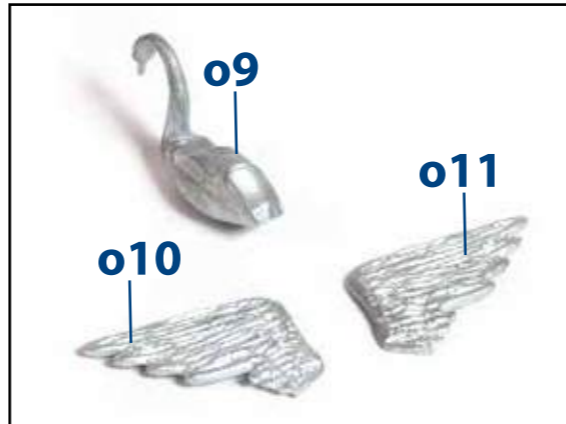
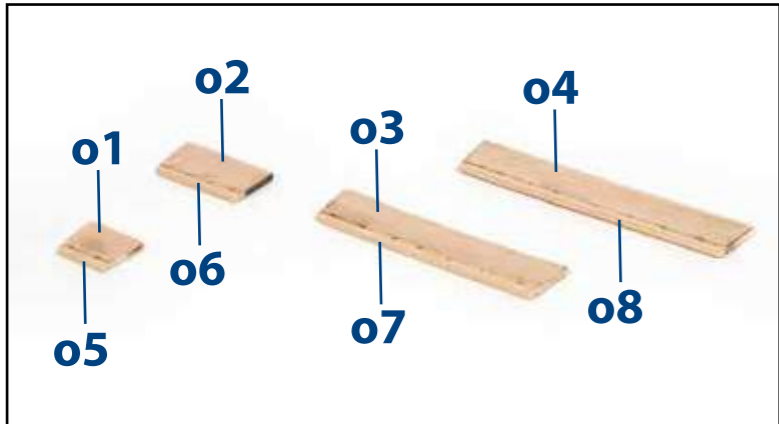

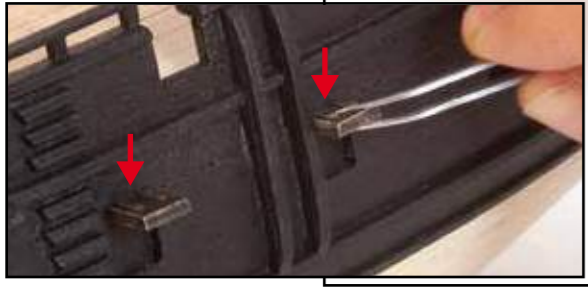
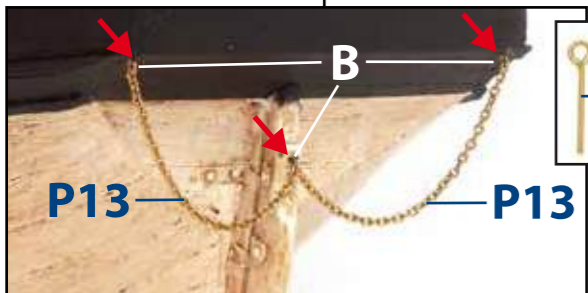
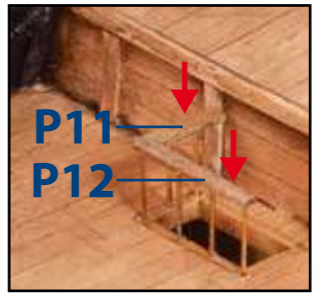
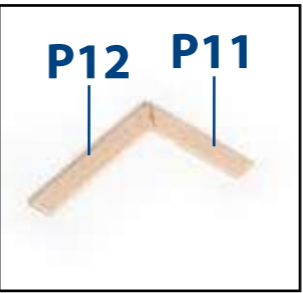
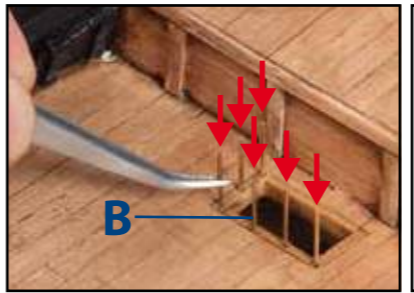
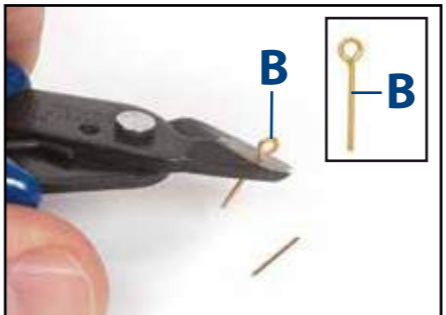
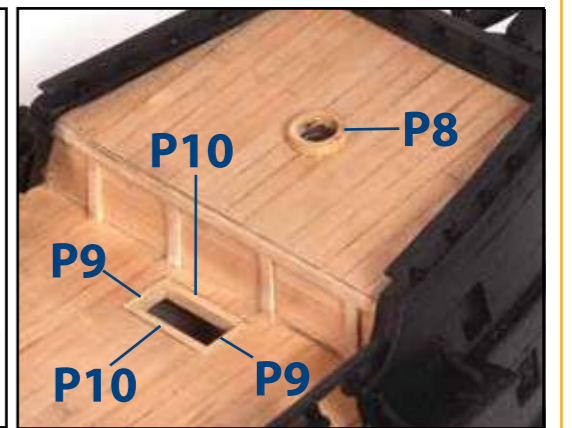
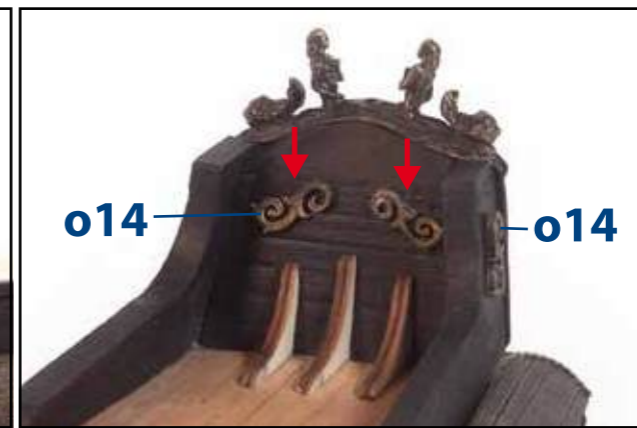
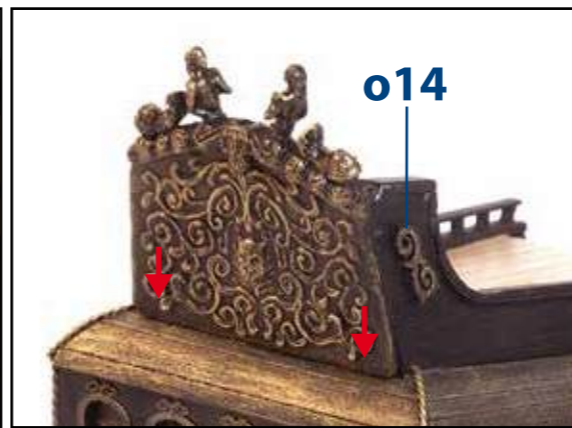
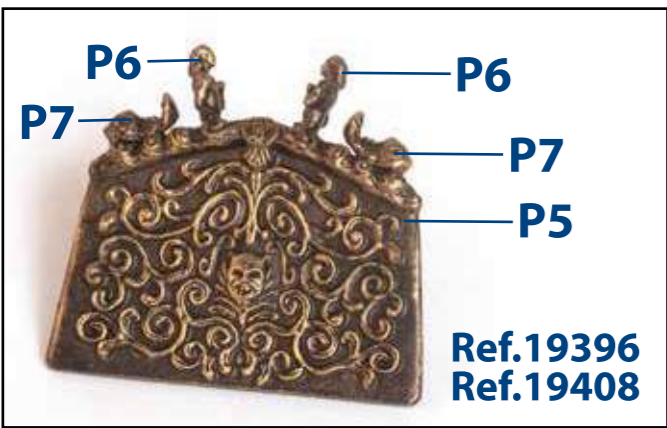
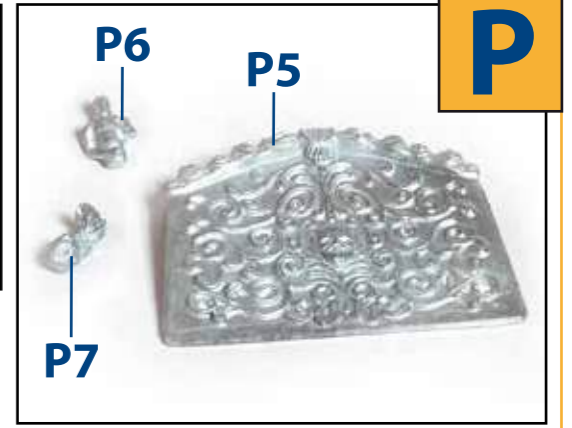
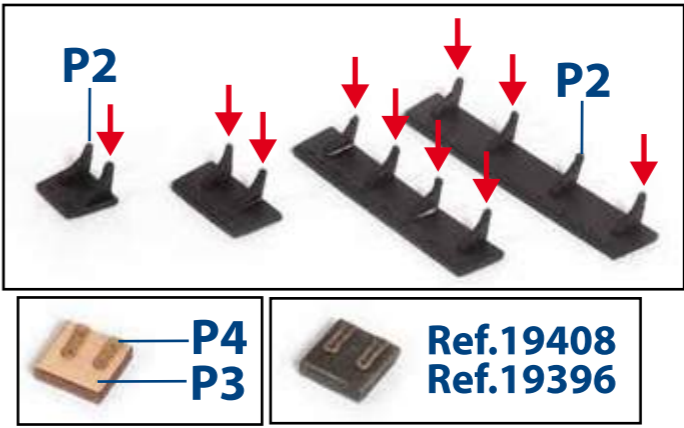
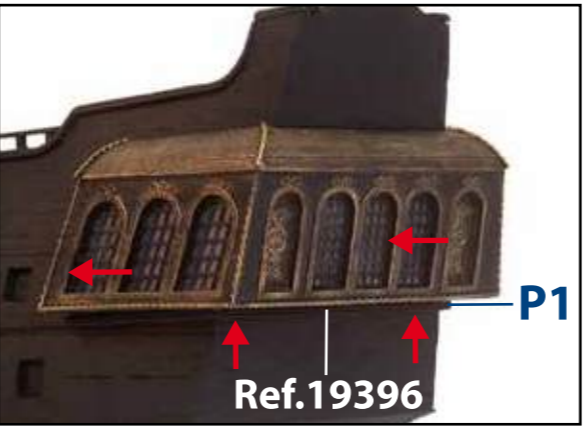
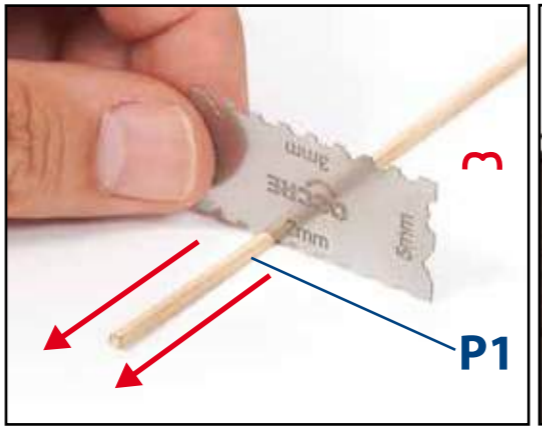
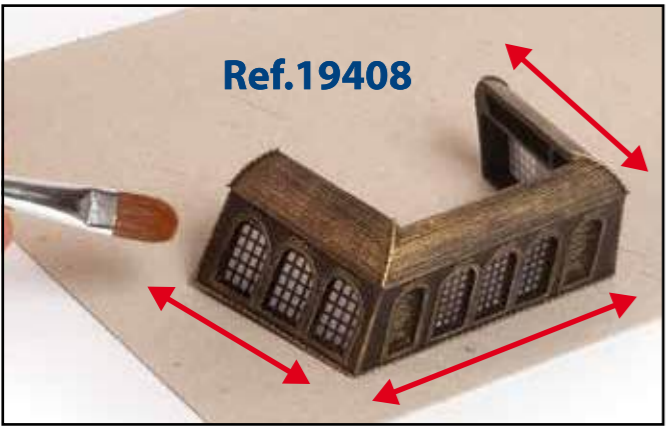

Q

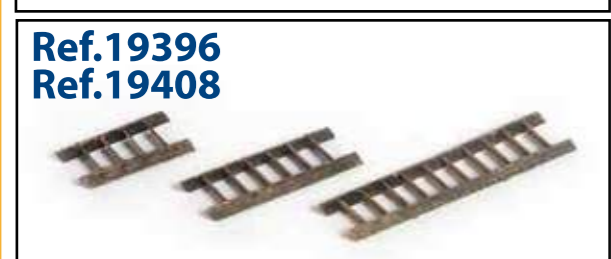
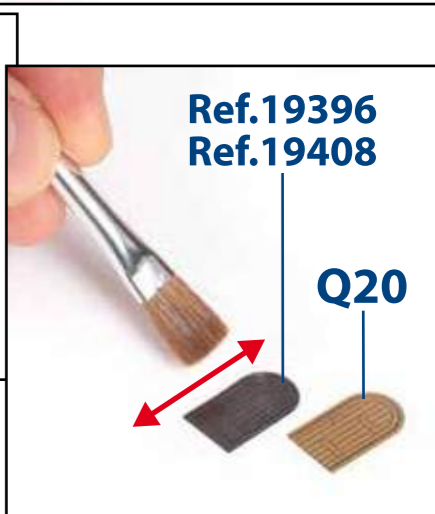
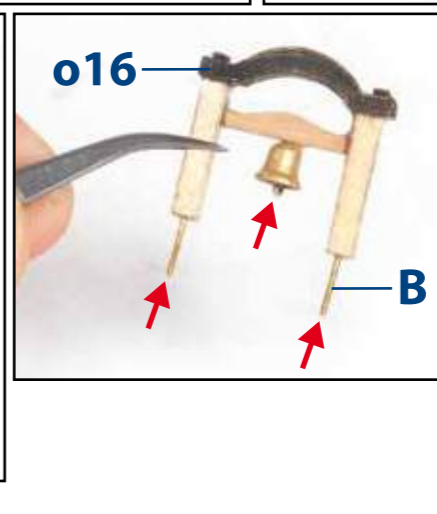
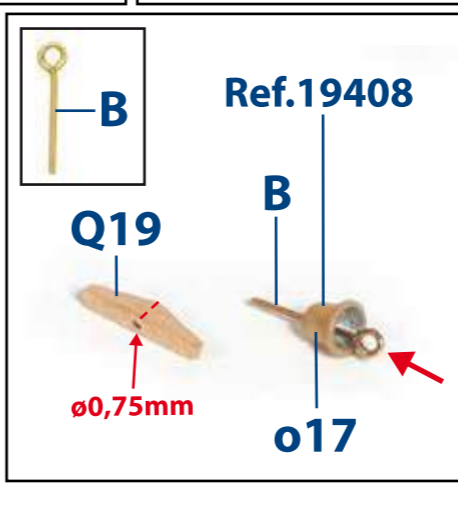
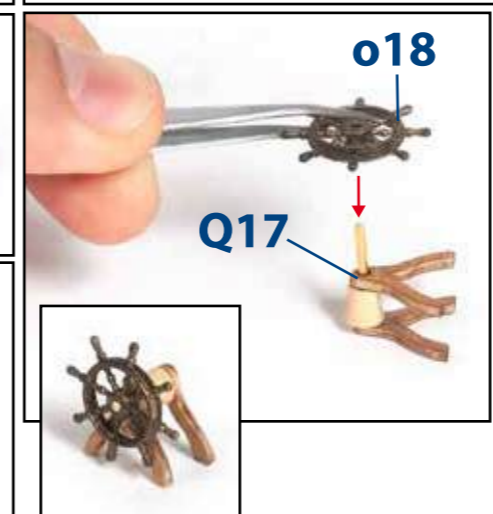
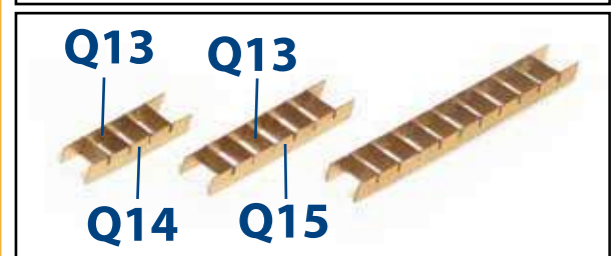
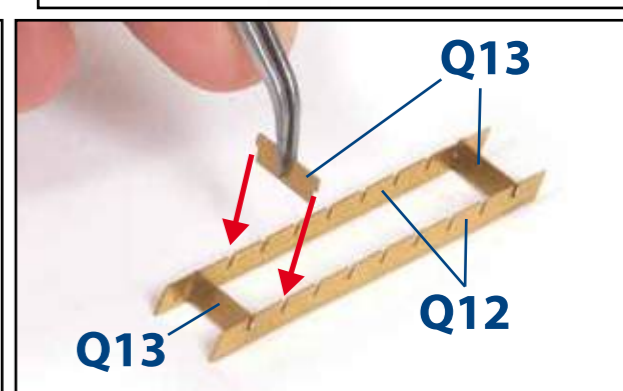
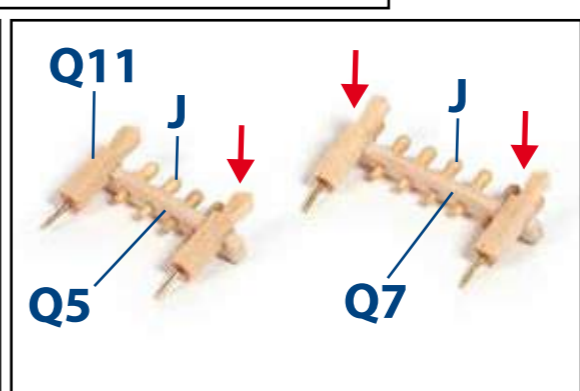
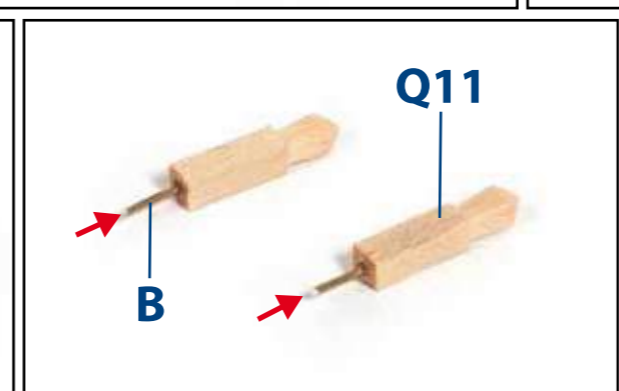
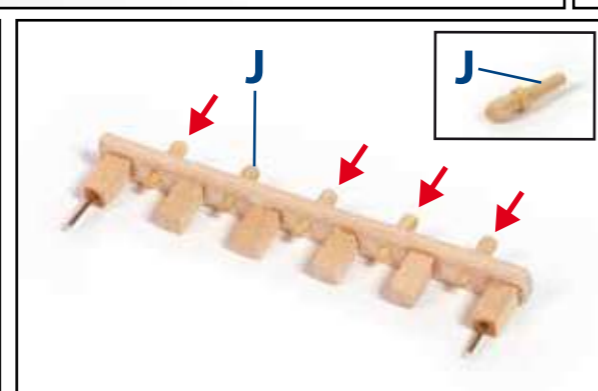
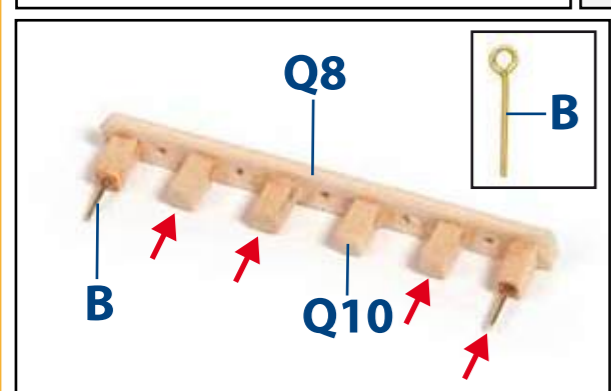
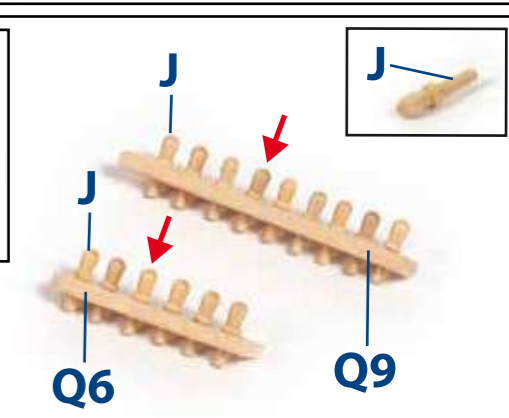
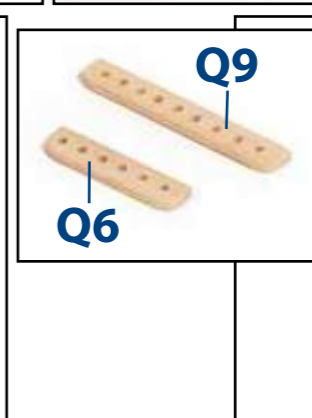
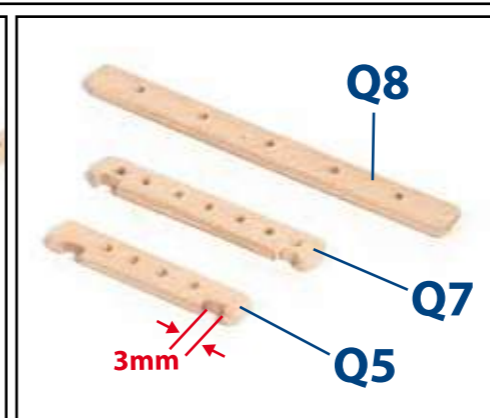
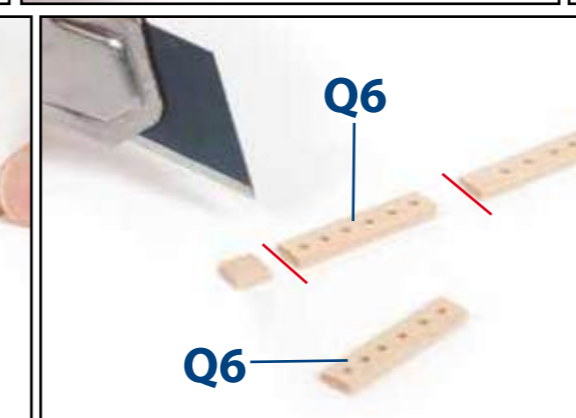
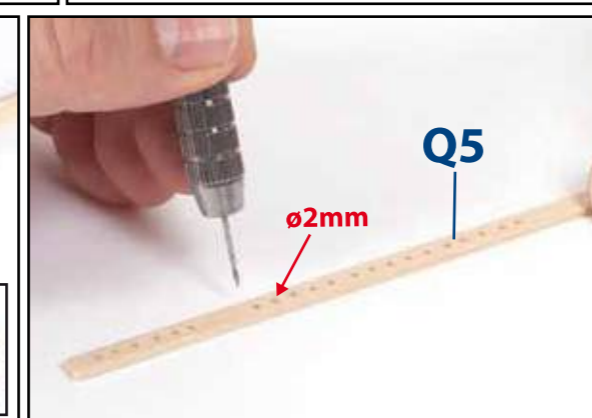
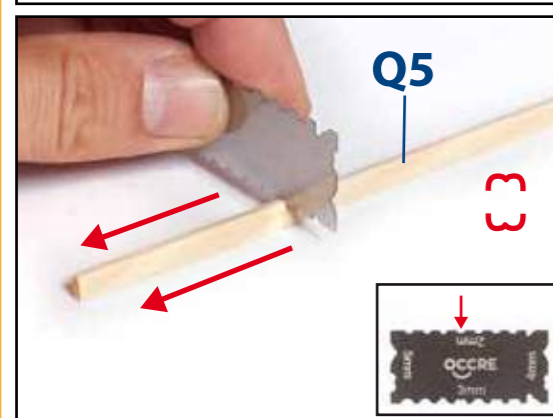
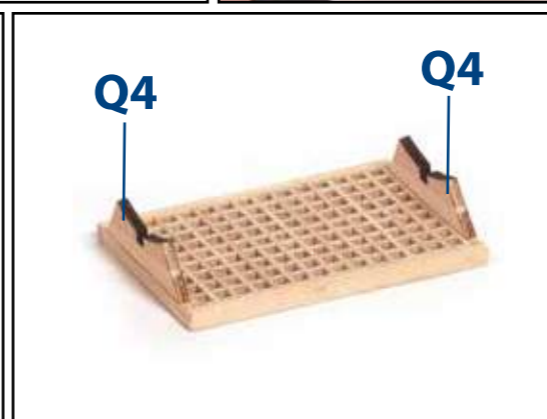
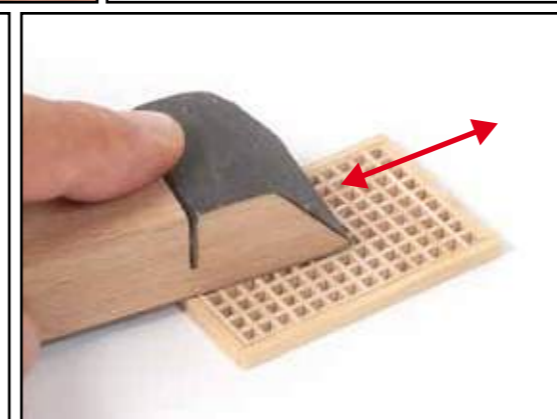
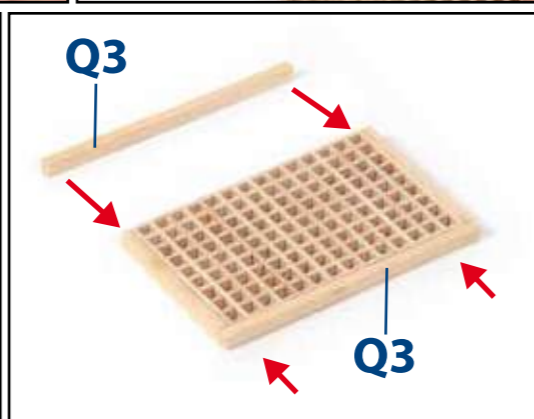
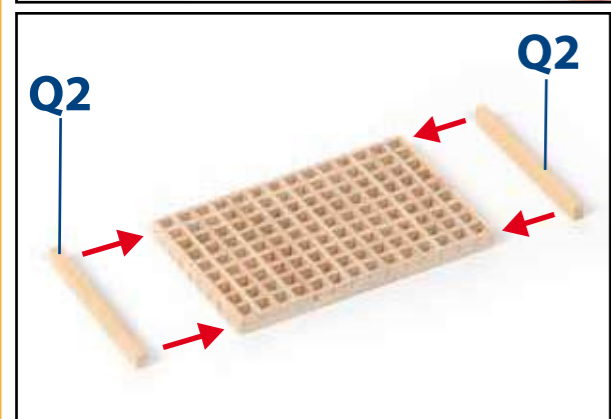
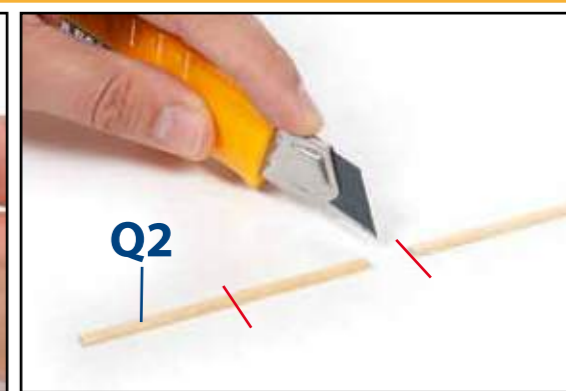
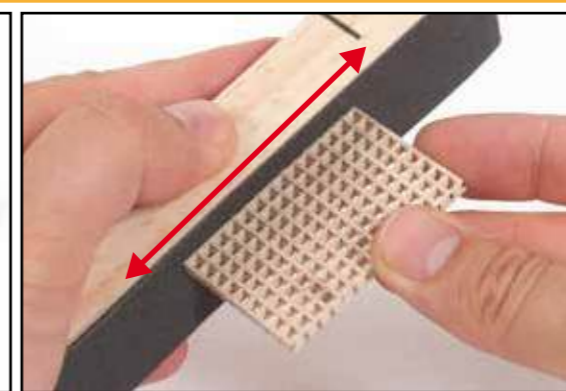
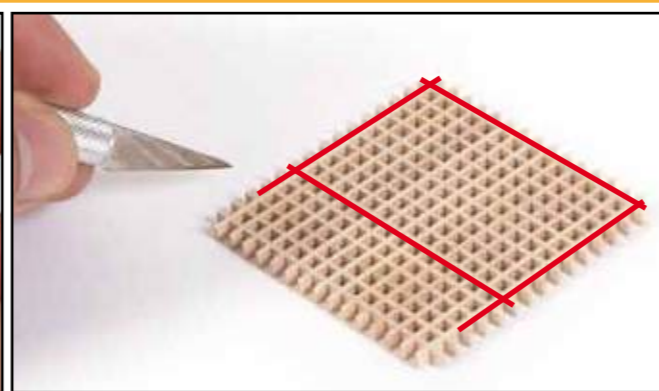
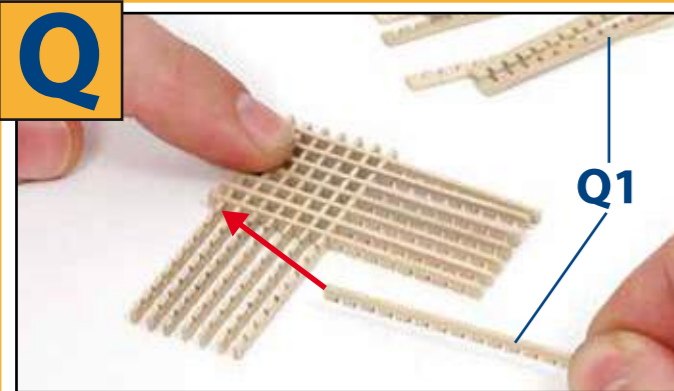

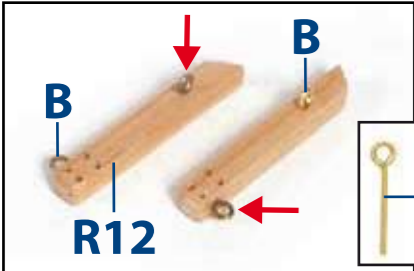
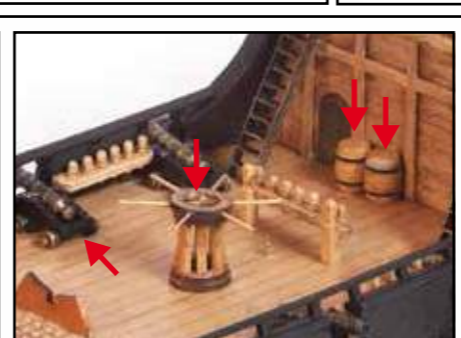
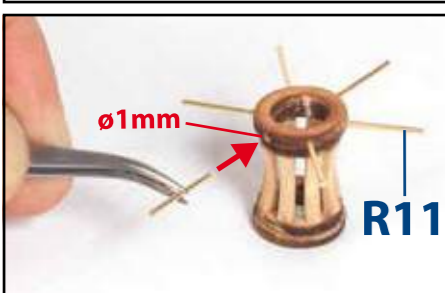
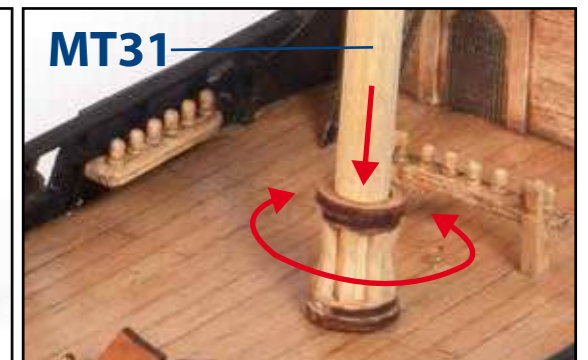
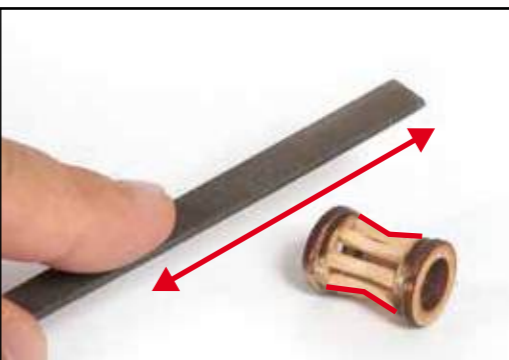
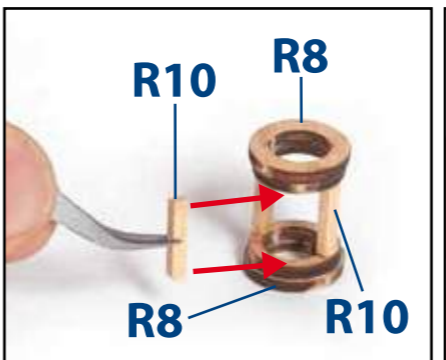
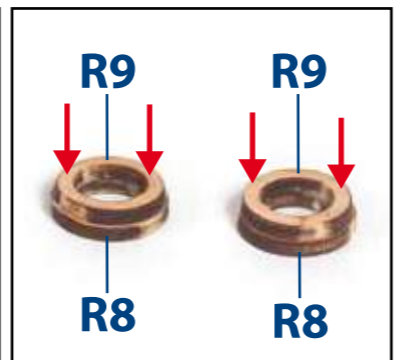
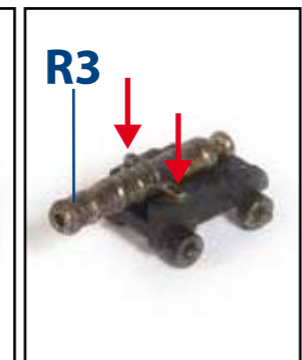
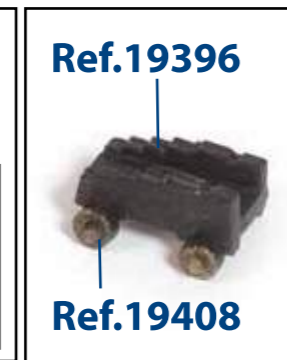
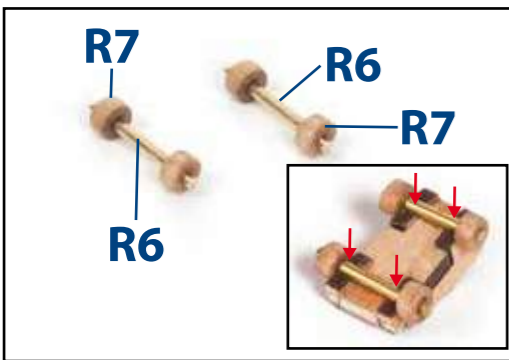
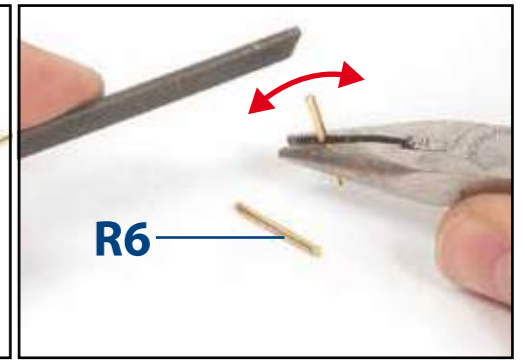
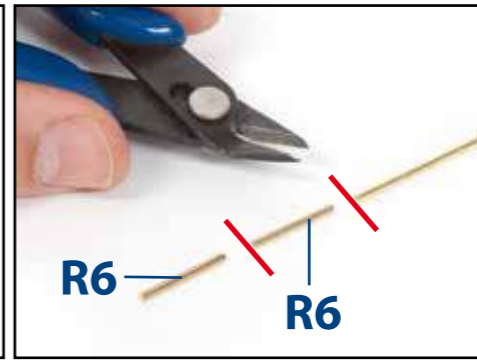
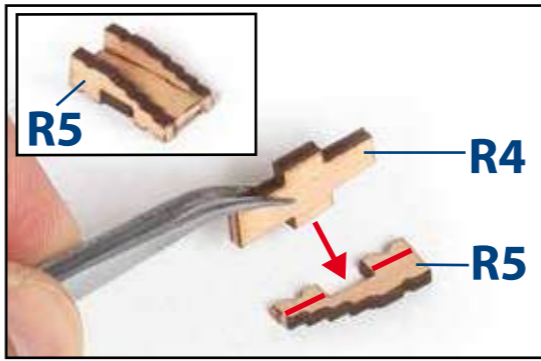
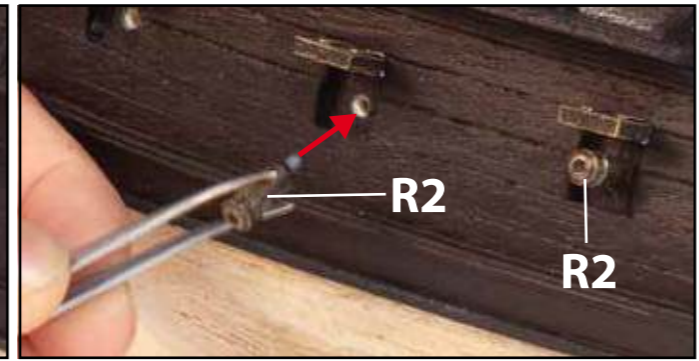
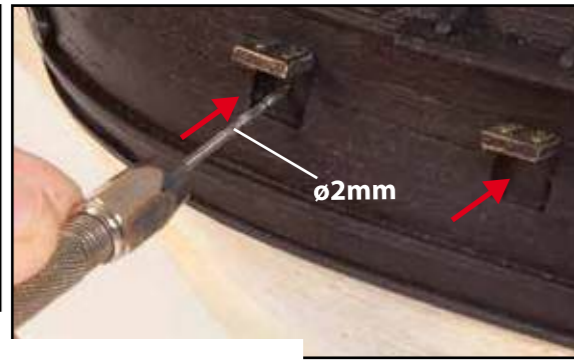
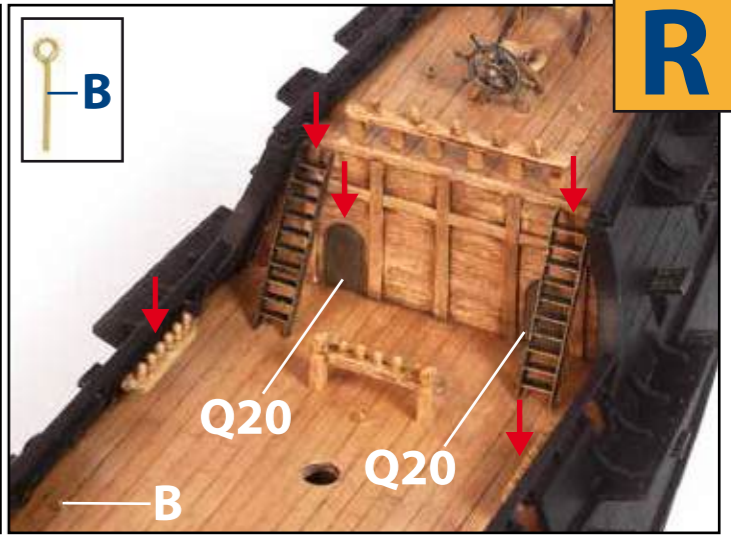
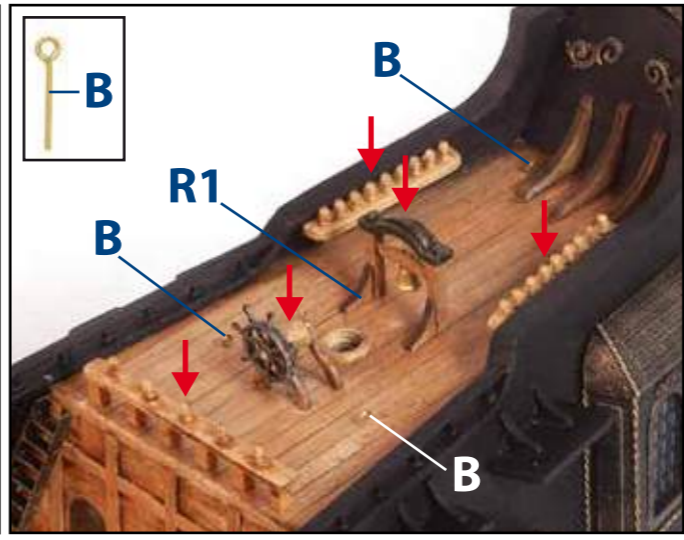
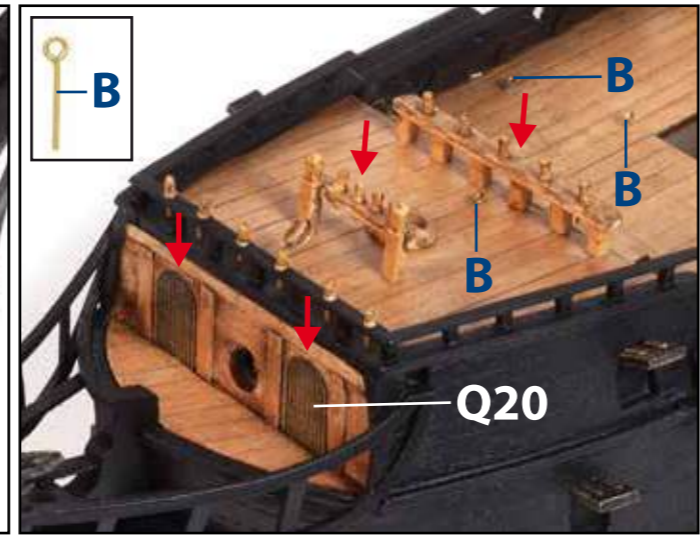
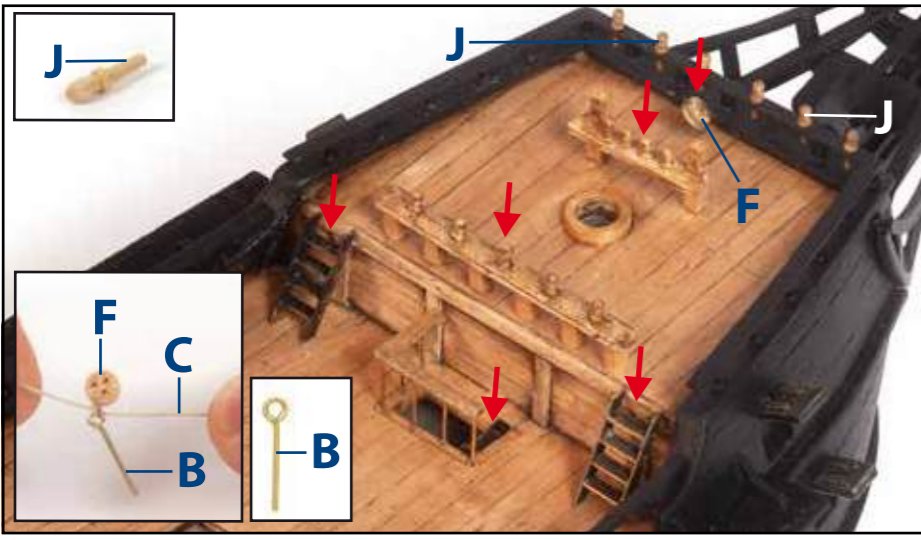

S

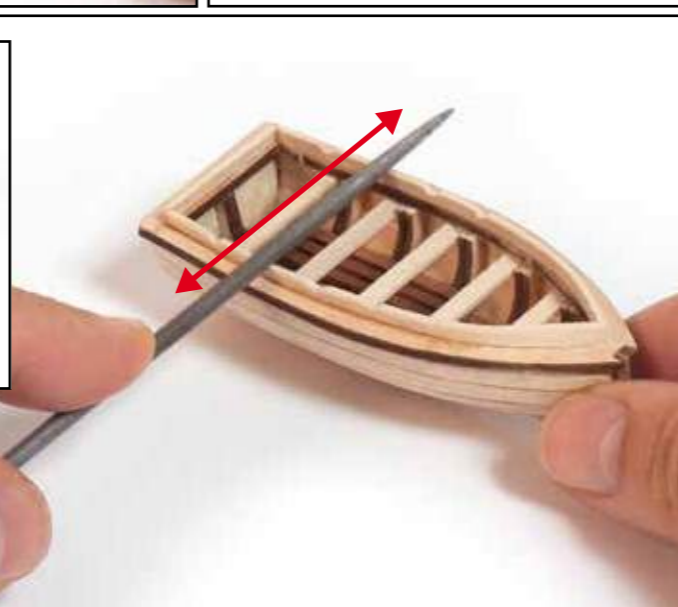
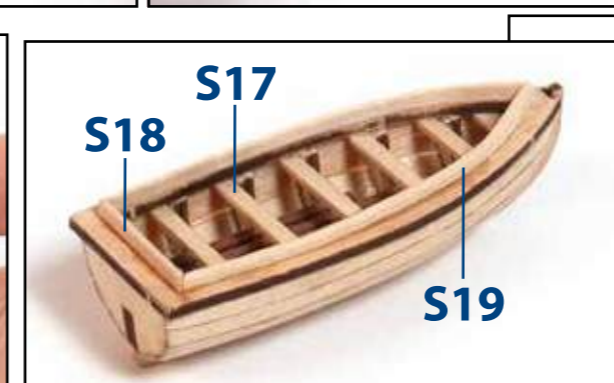
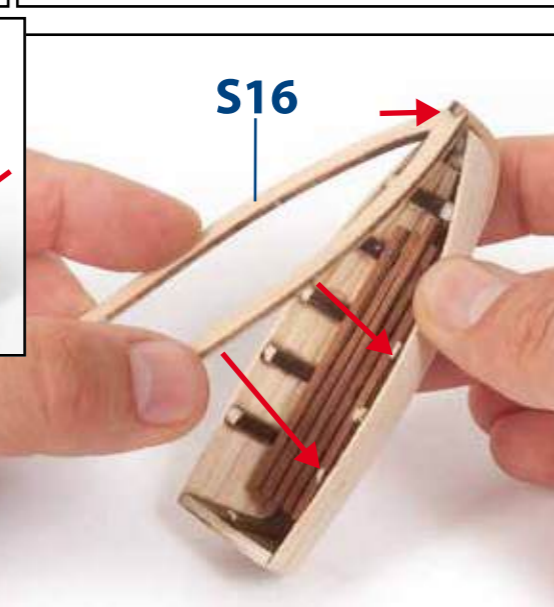
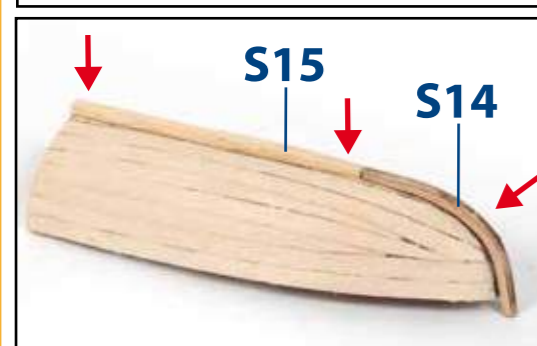
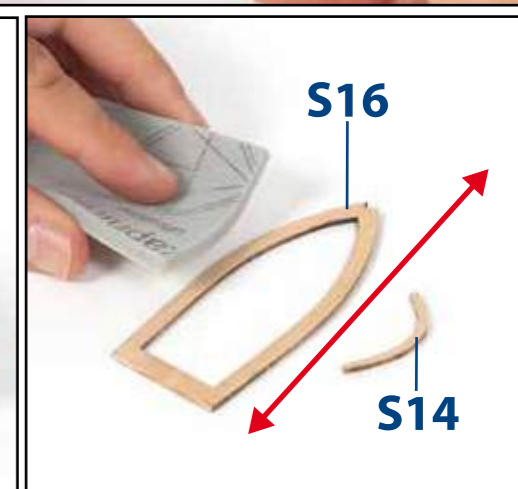
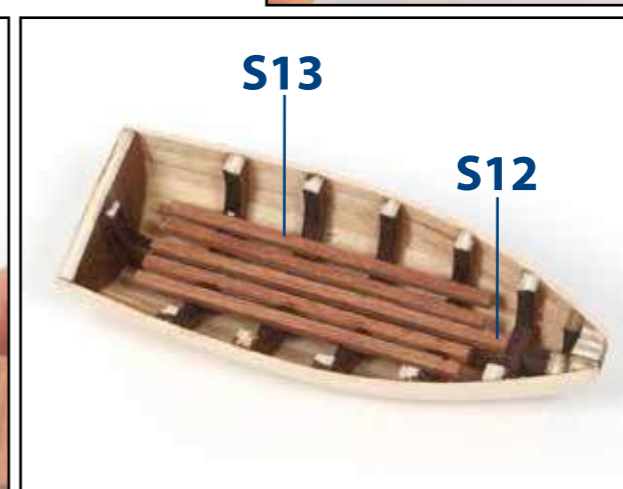
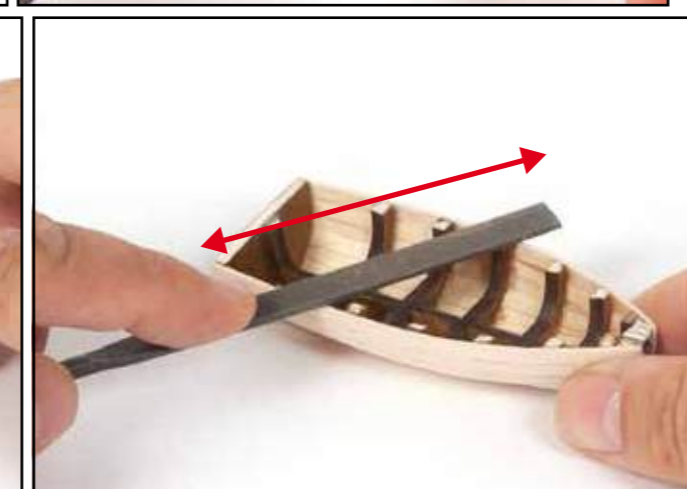
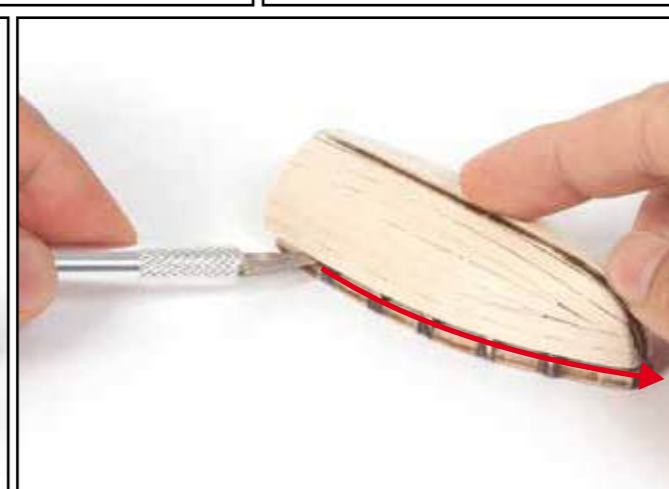
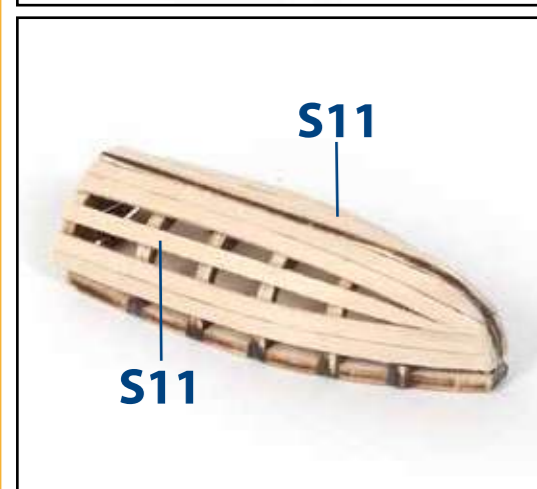
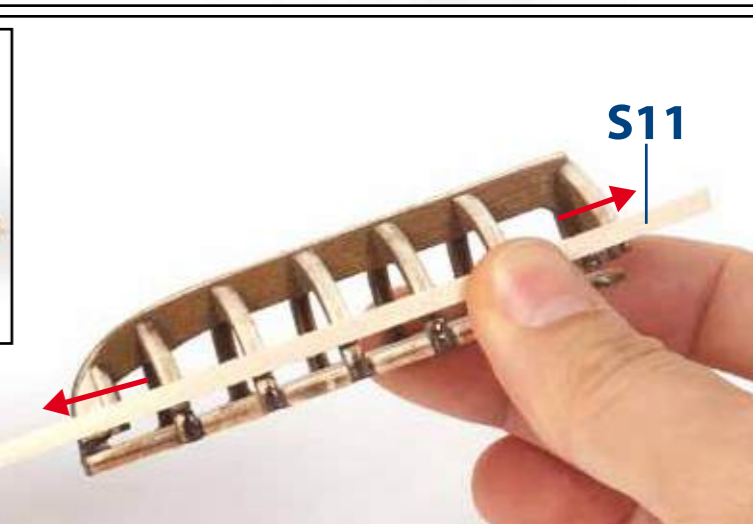
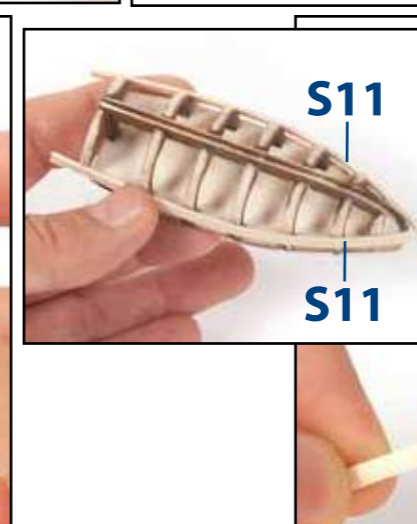
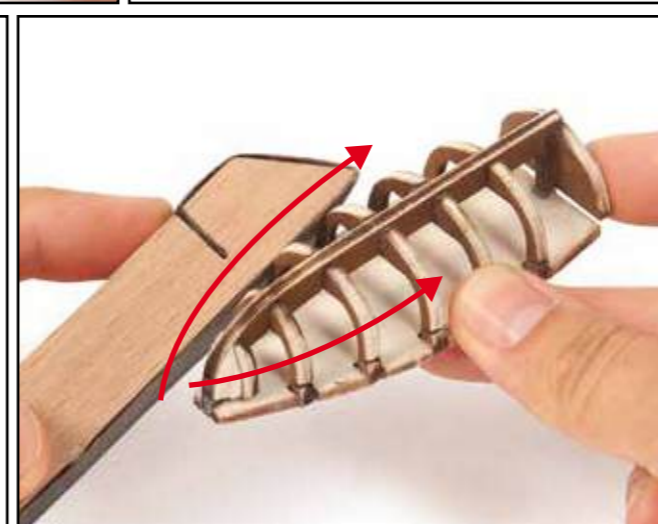
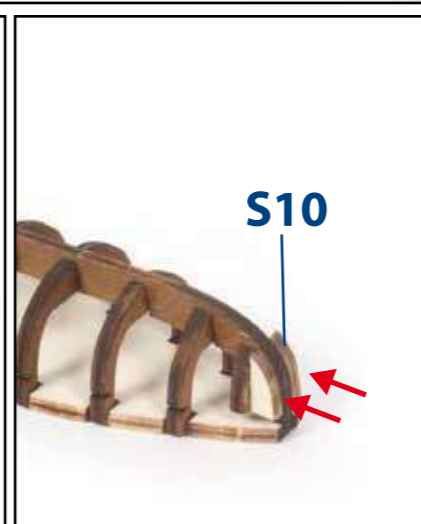
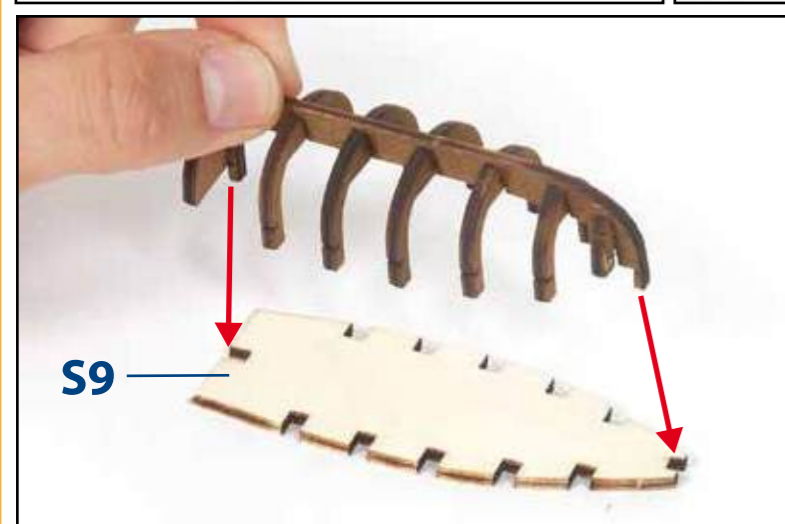
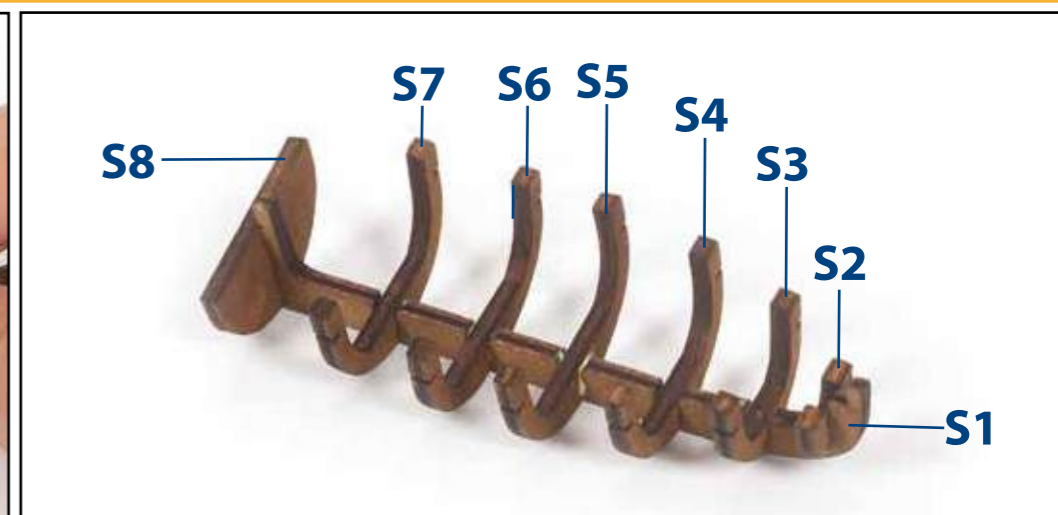
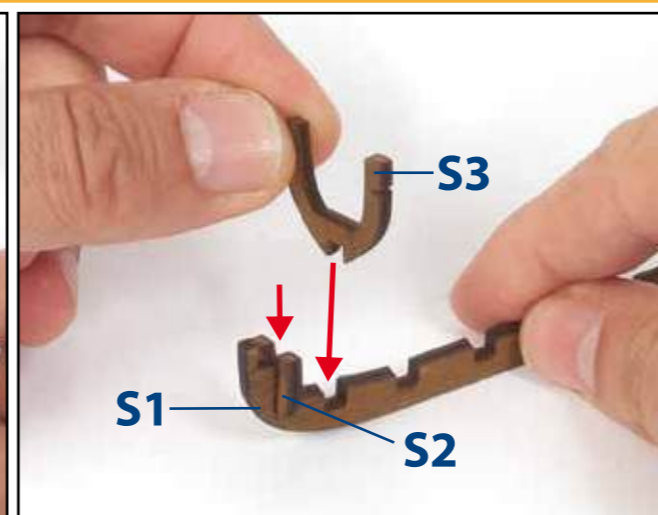

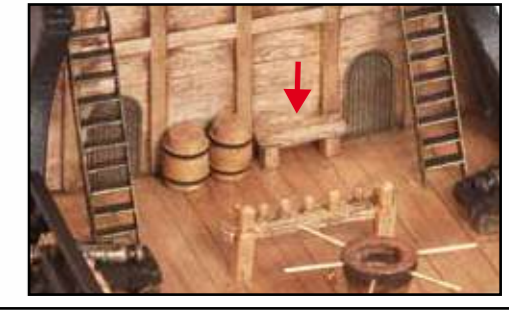
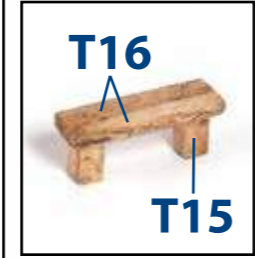
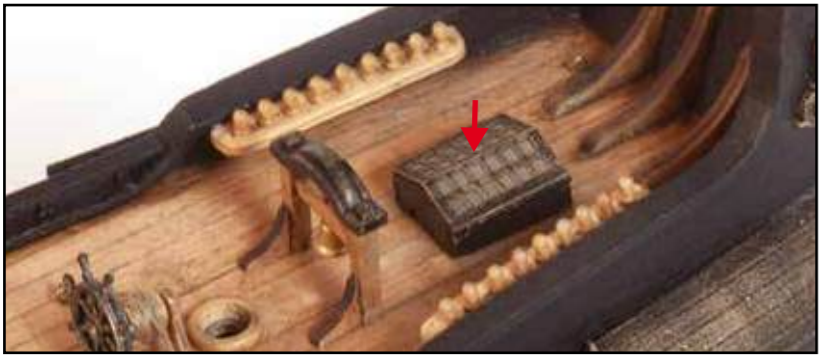
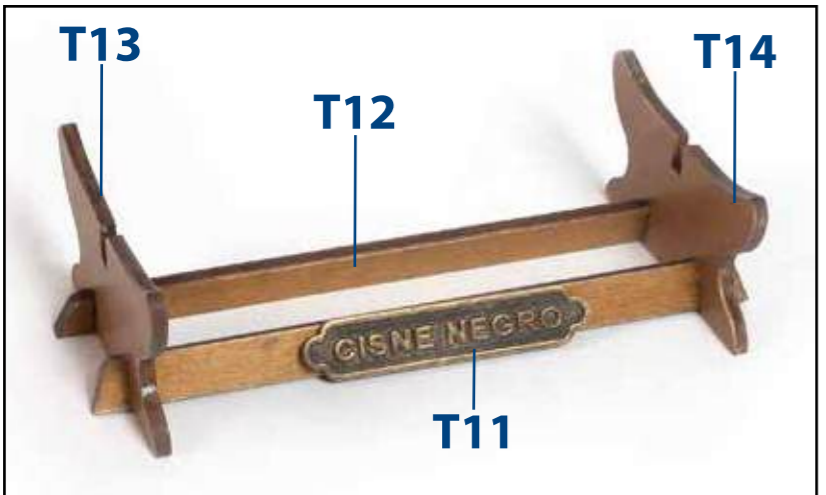
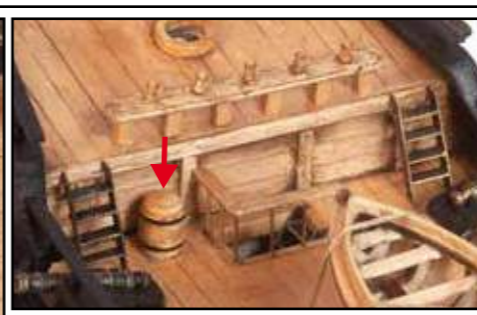
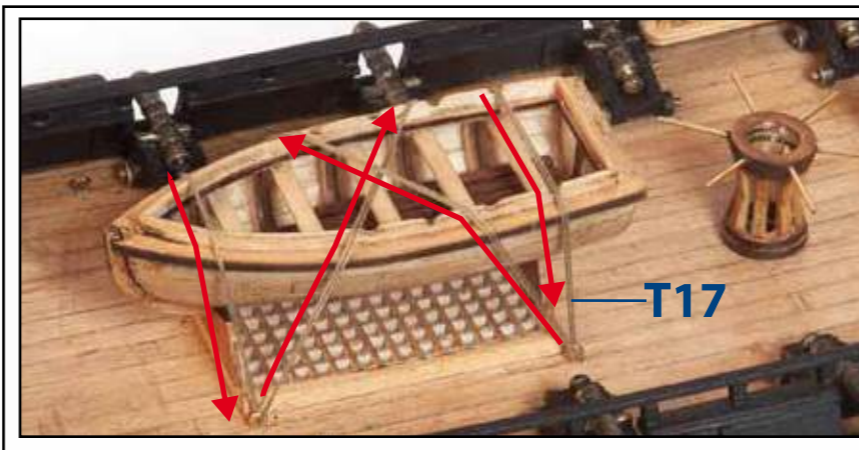
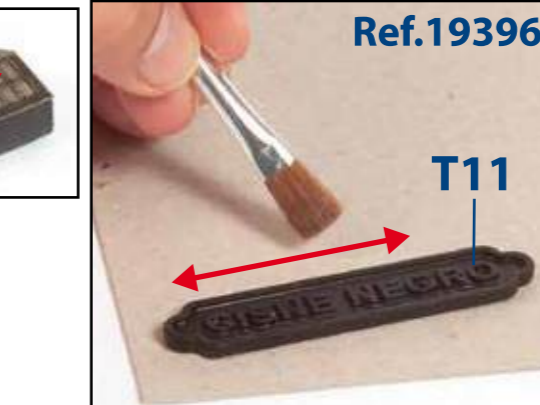
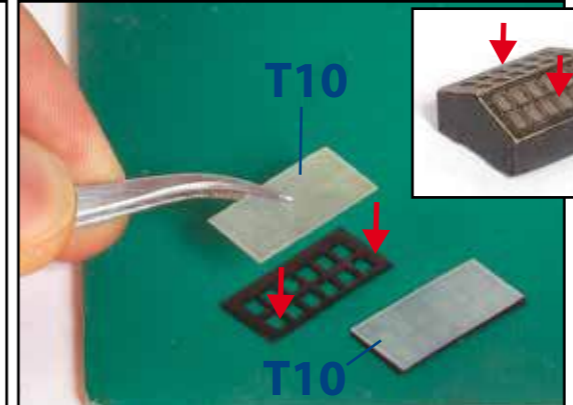
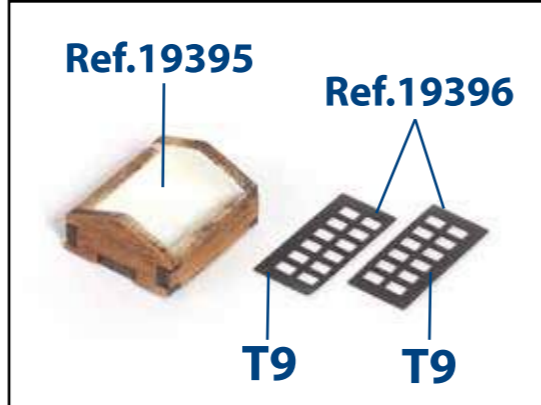
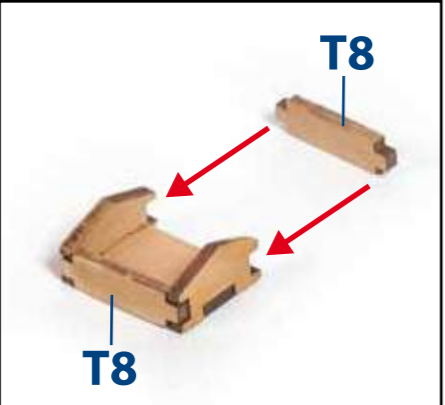
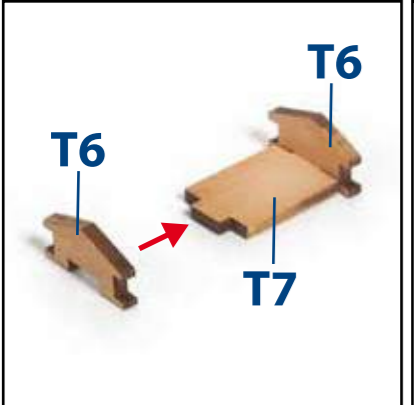
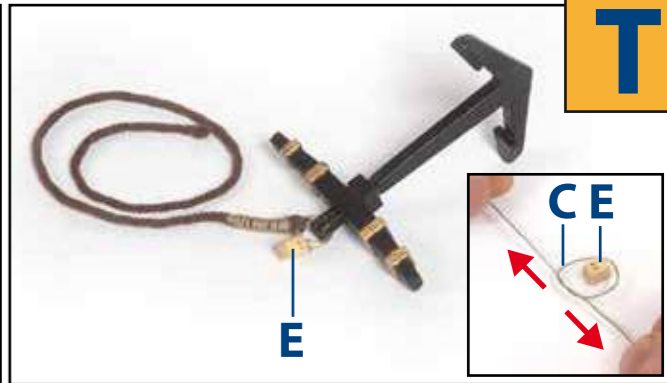
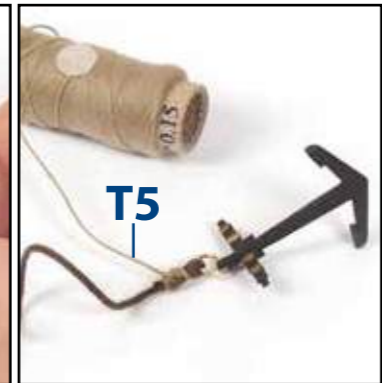
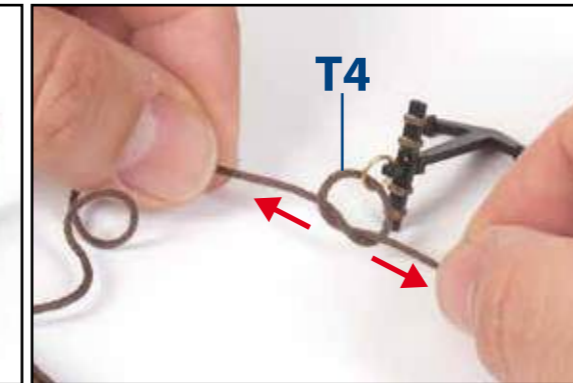
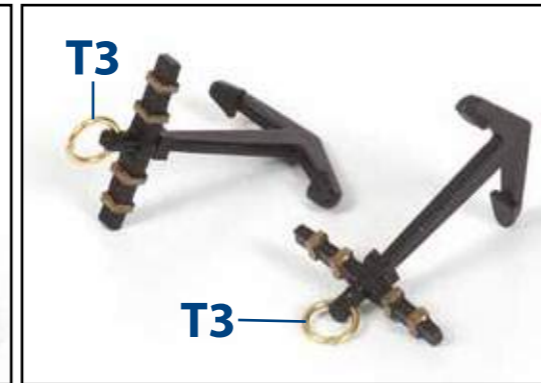
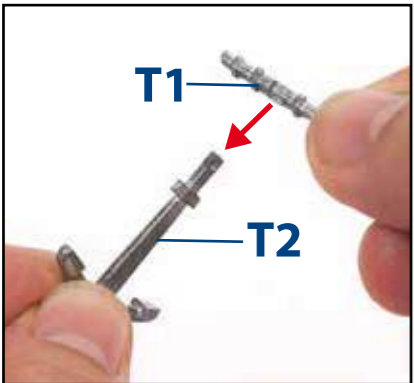

U

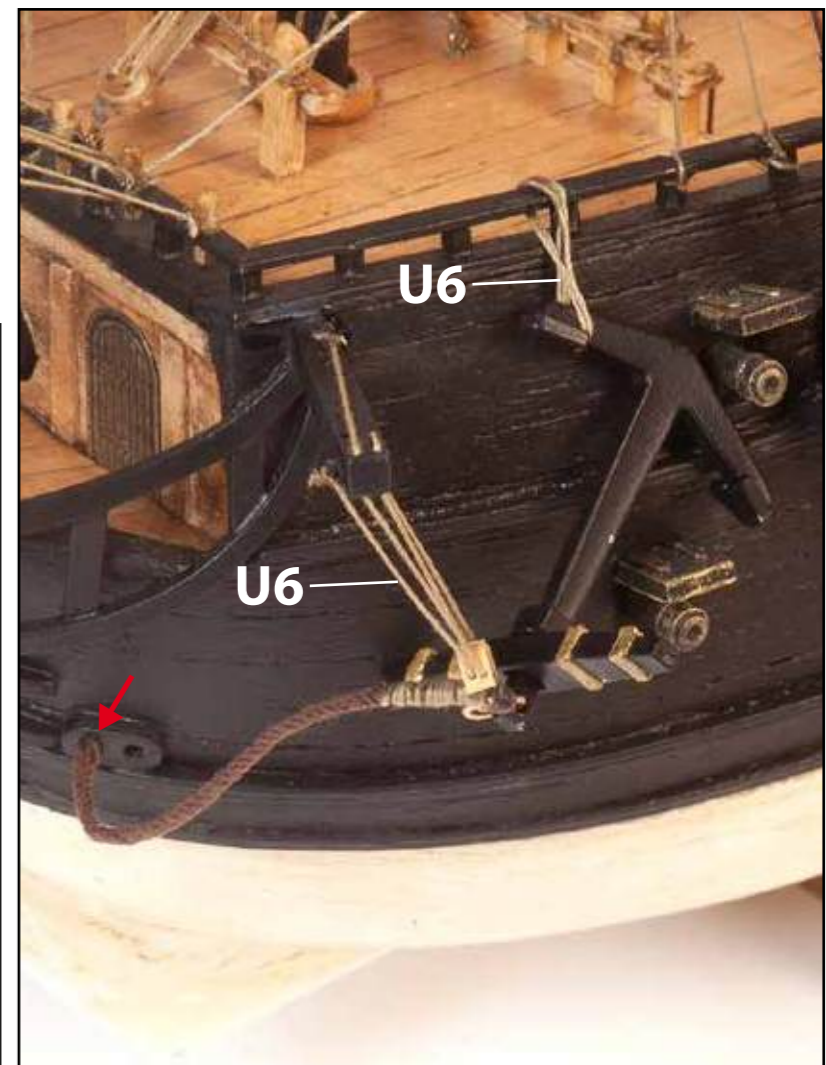
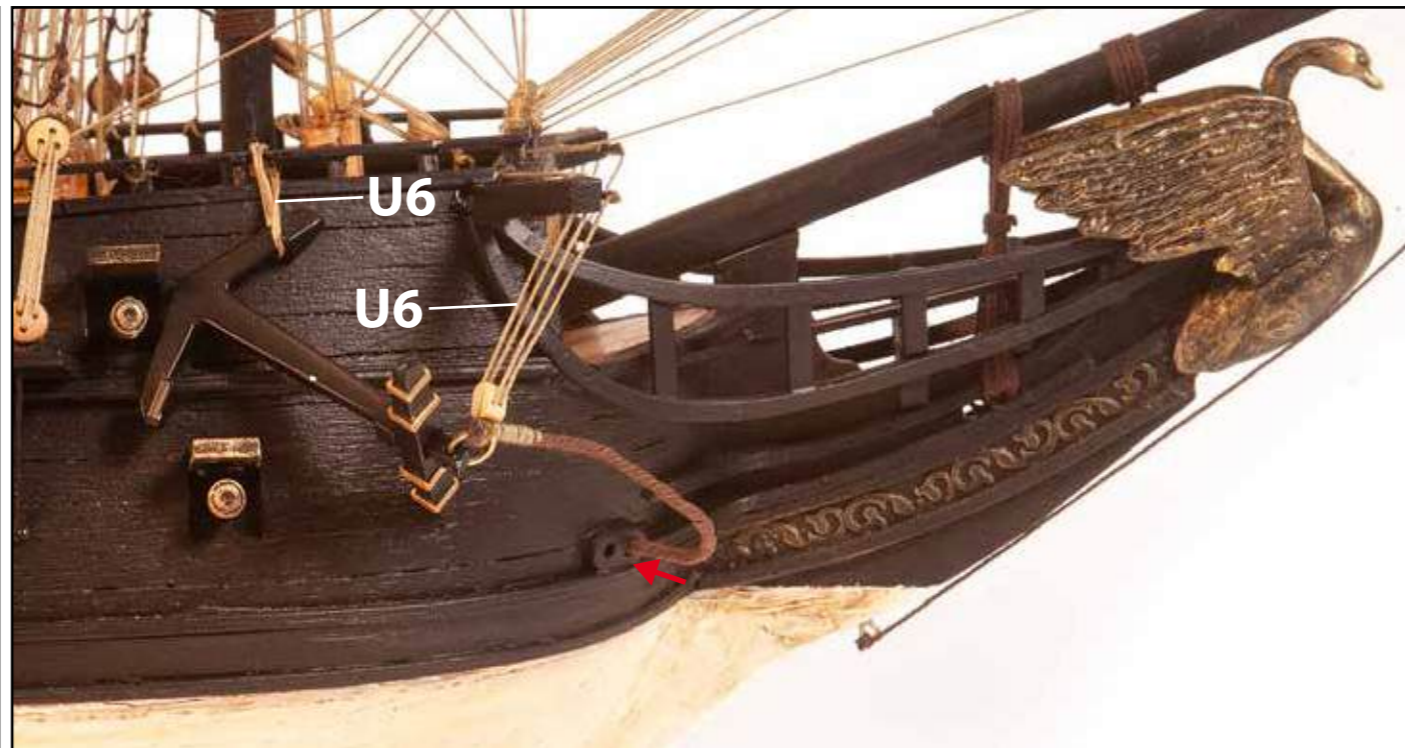
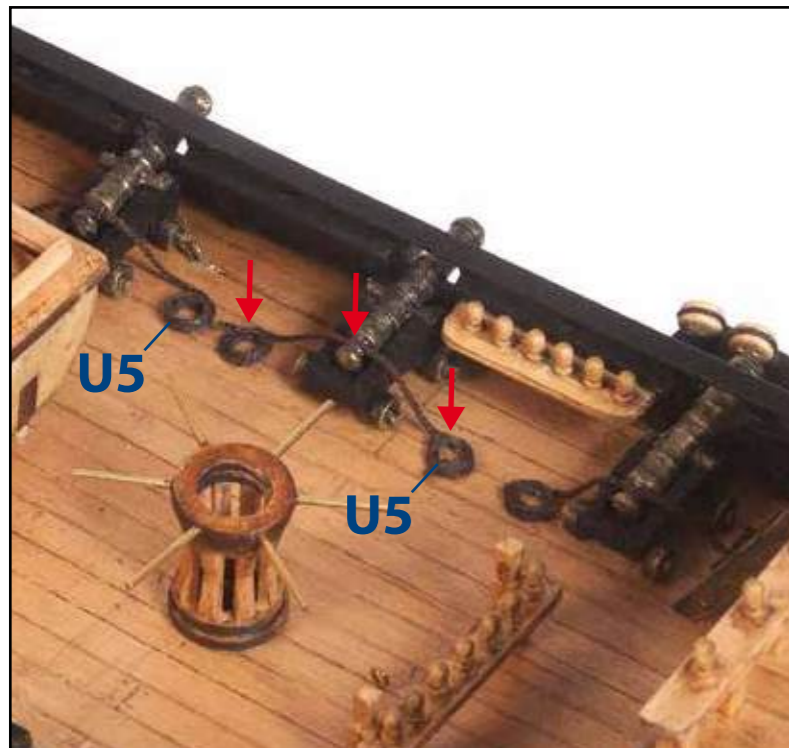
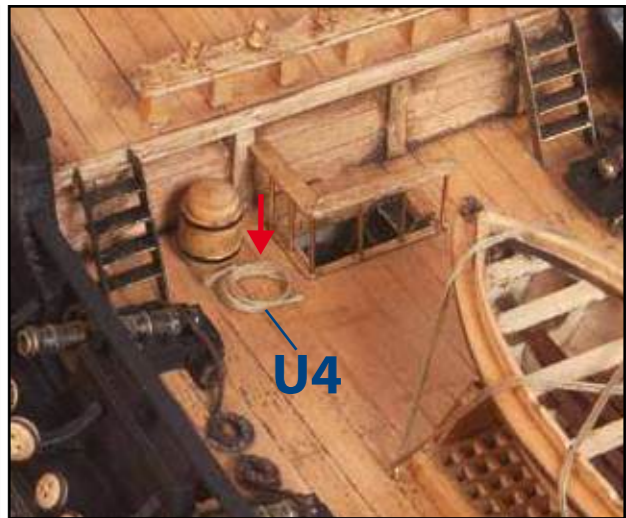
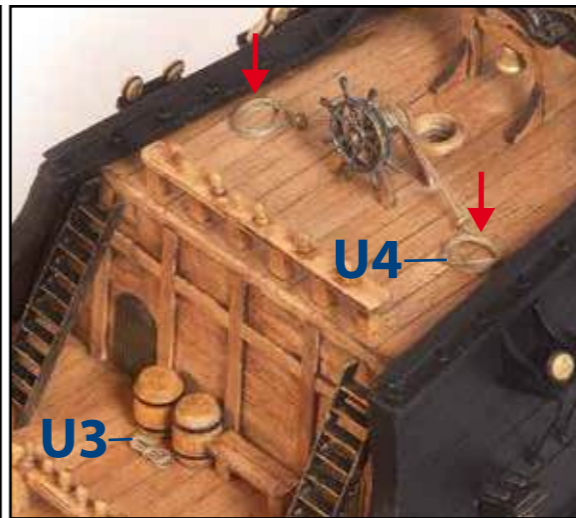
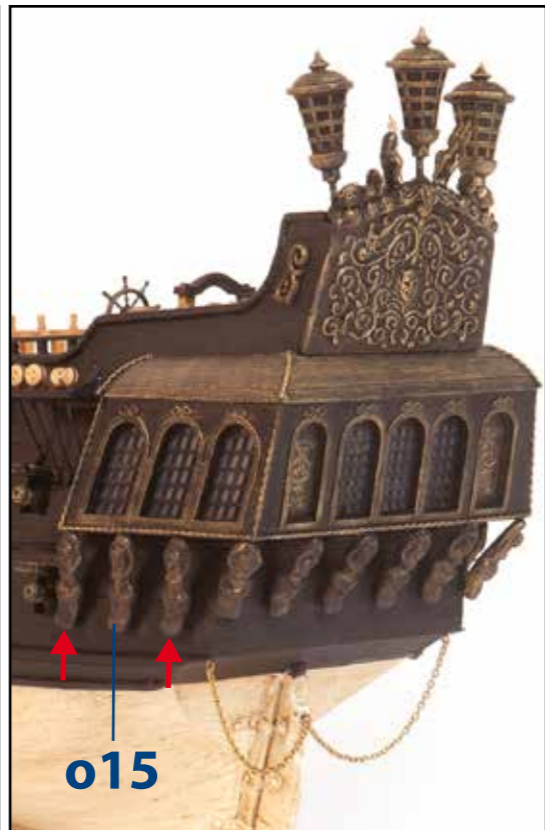
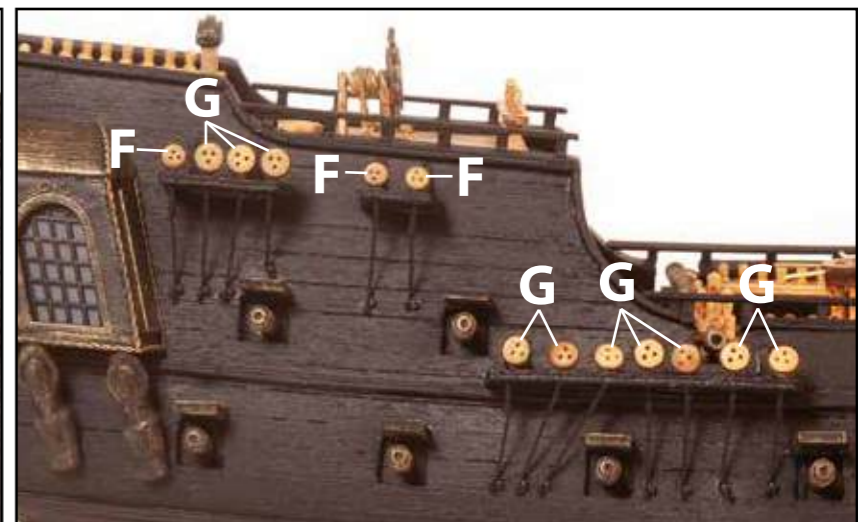
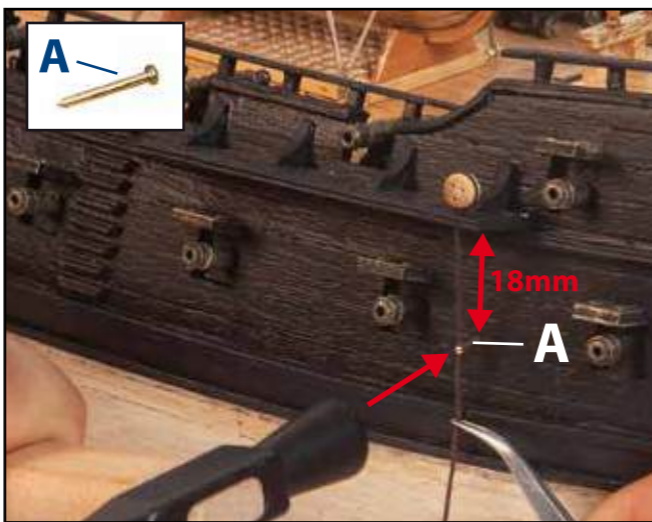
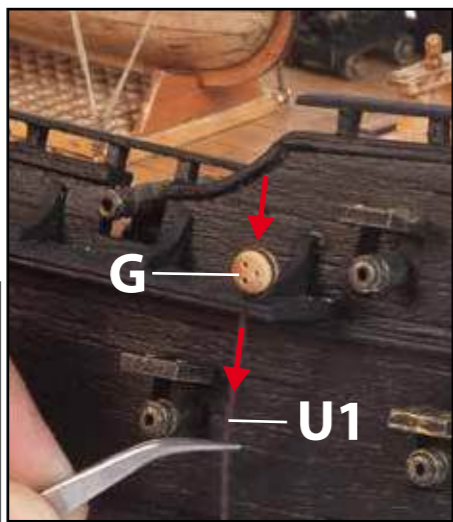
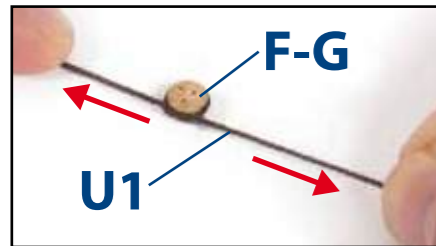
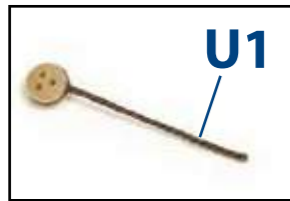

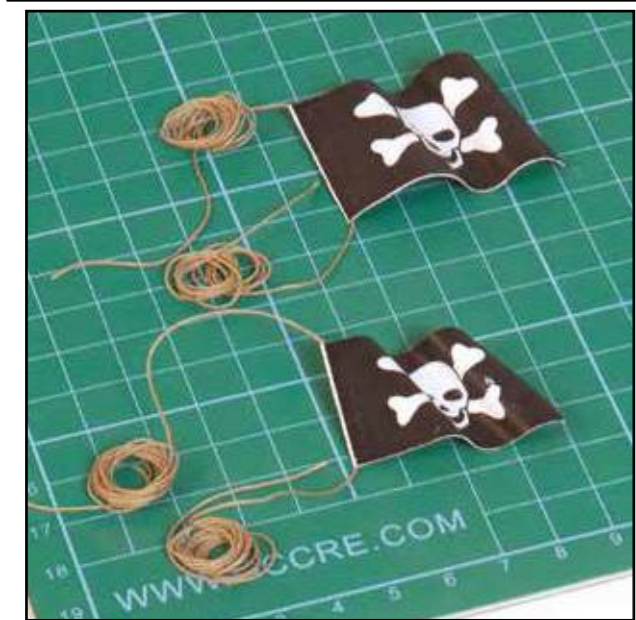

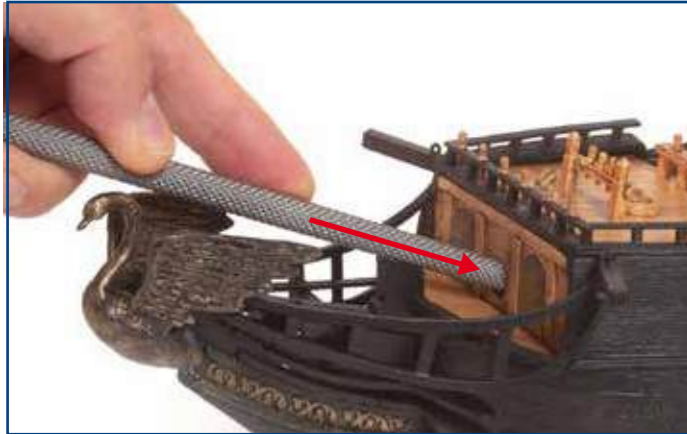
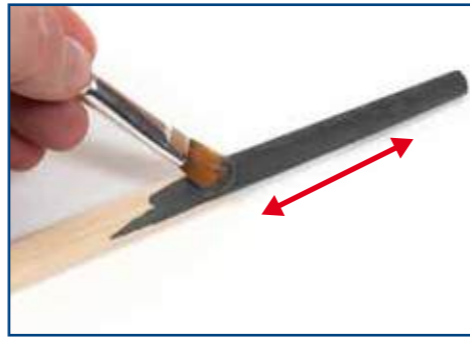
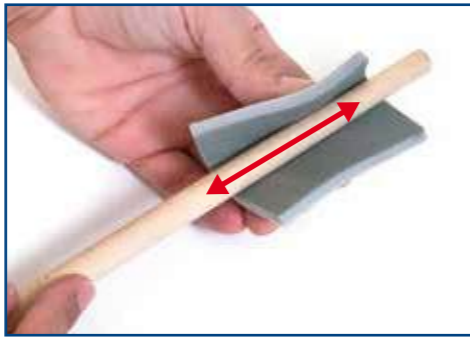
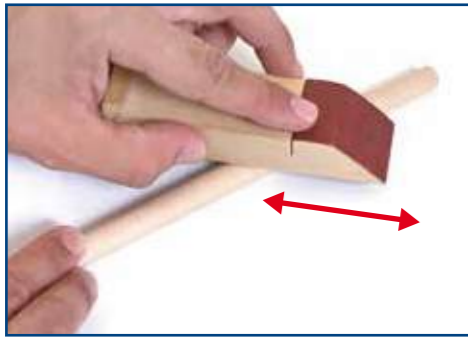

Consultar los planos de mástiles
 Consult the masts drawings
 Consulte os desenhos dos mastros
 Consulter les dessins des mâts
 Konsultieren Sie die Mastenzeichnungen
 Обратитесь к рисункам мачты
 Consultare i disegni degli alberi

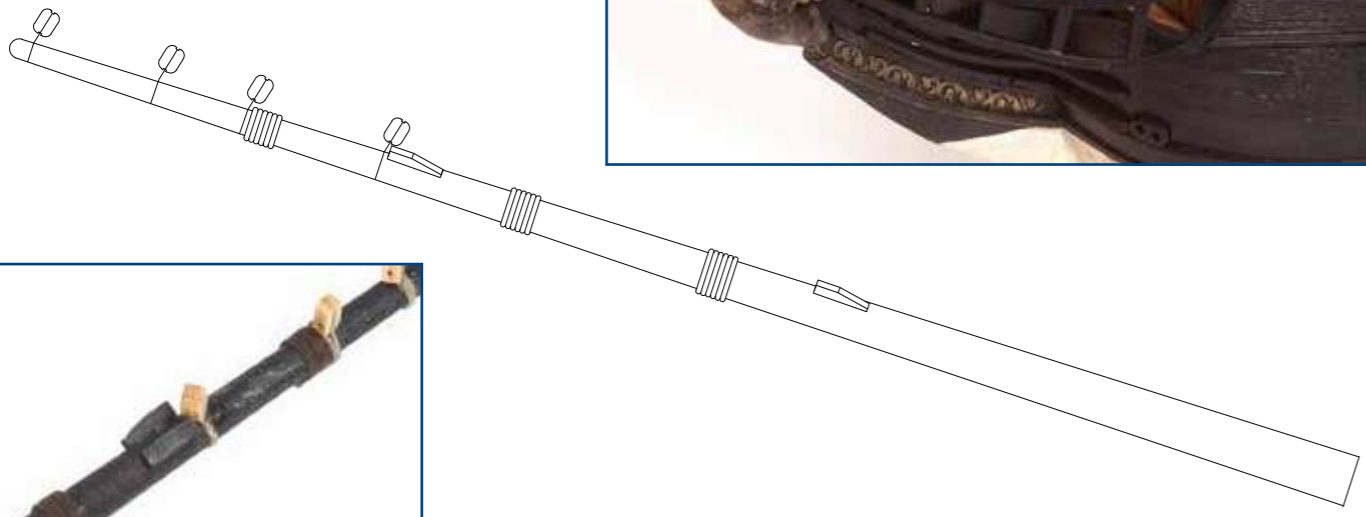
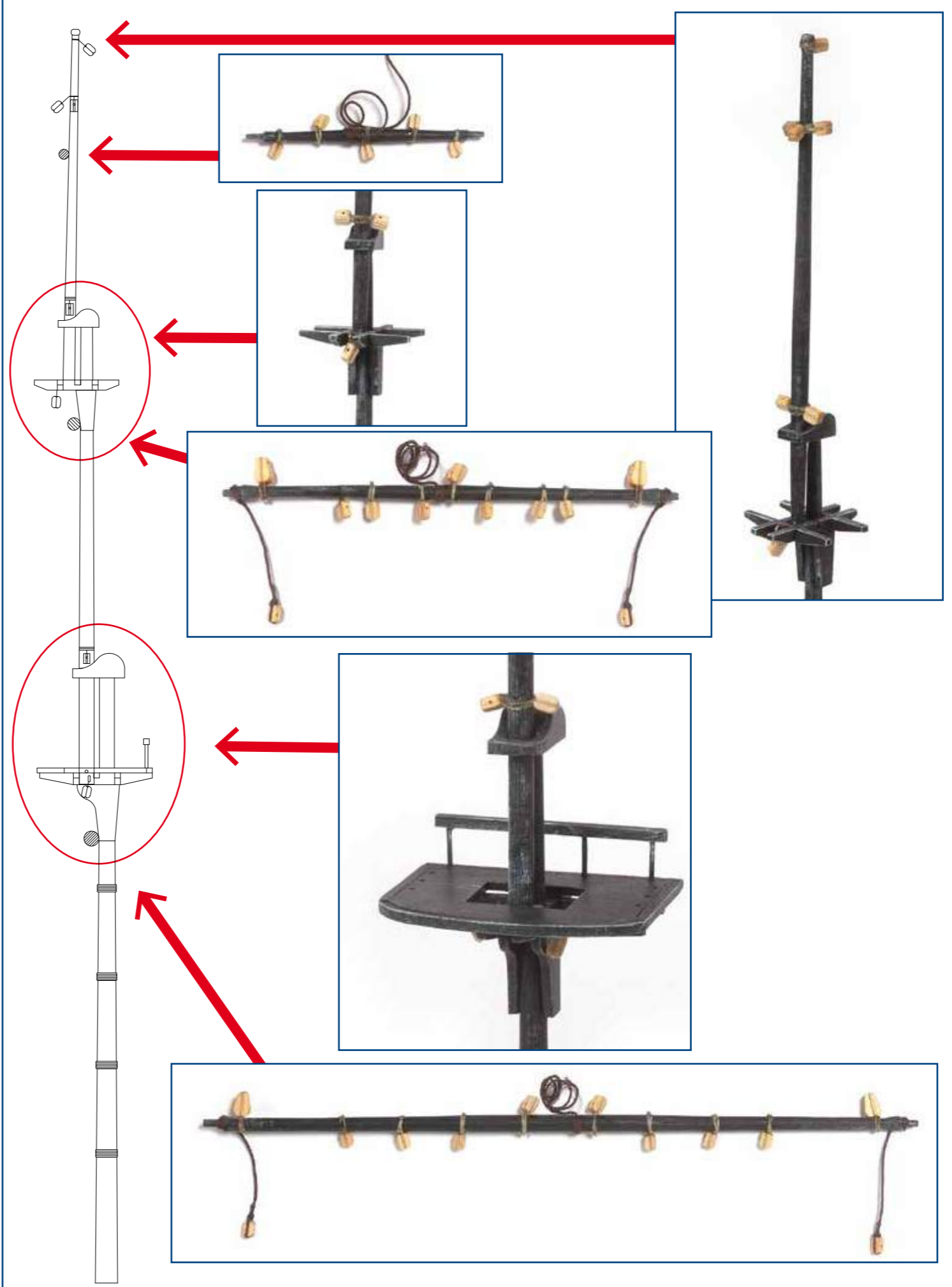
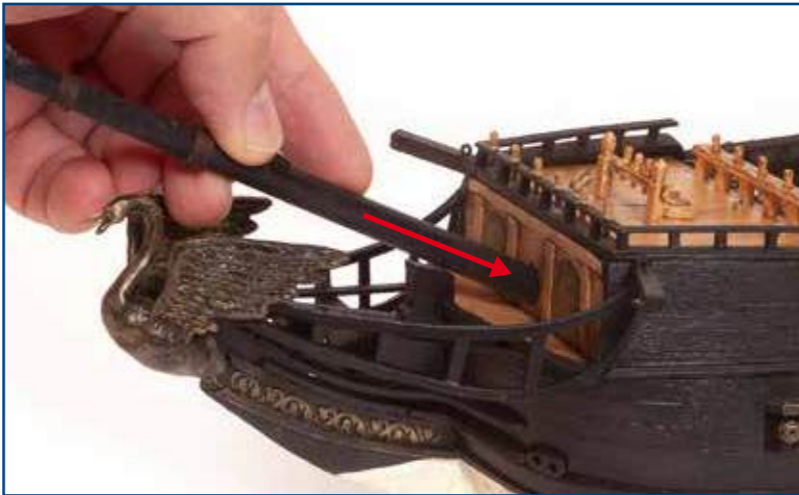

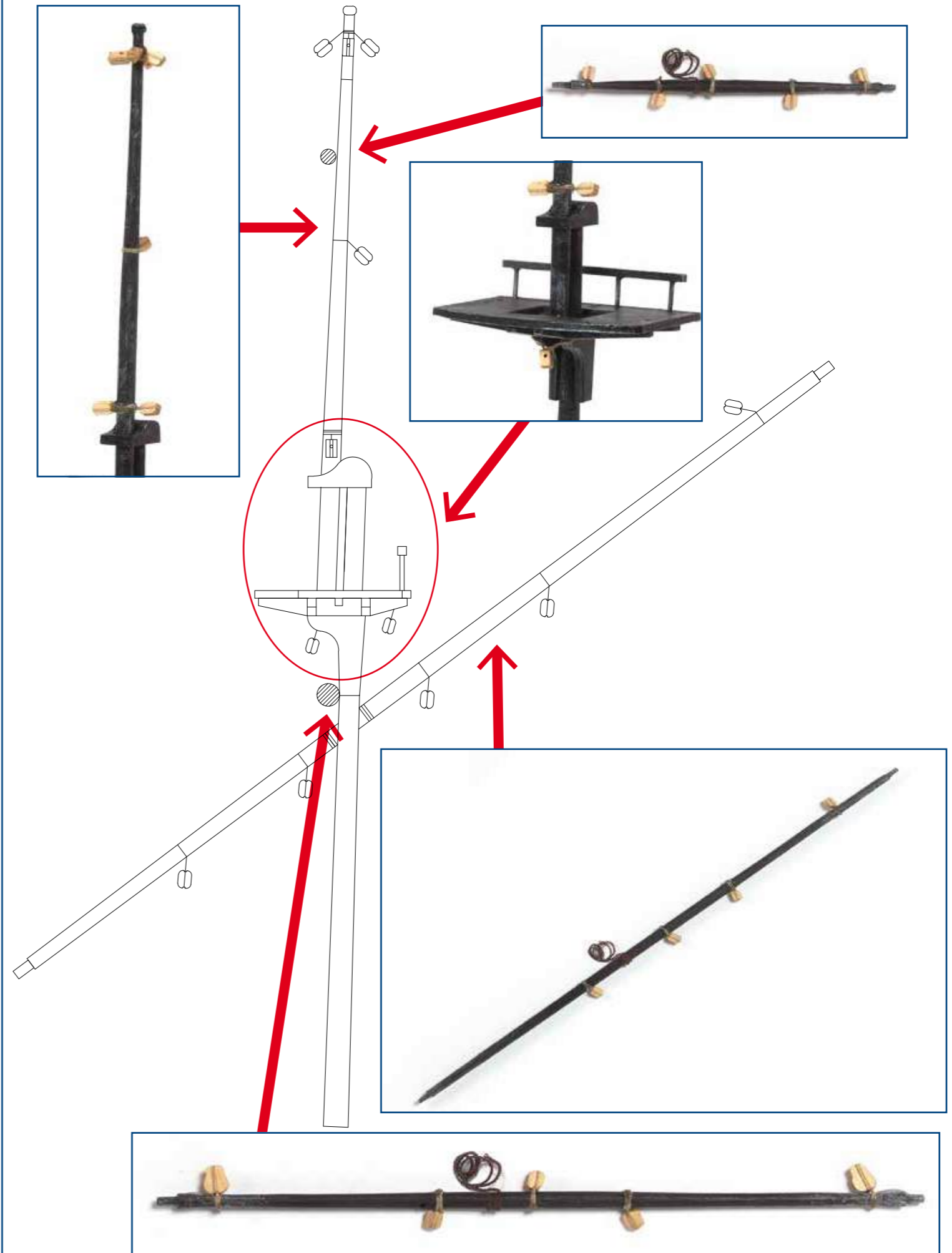
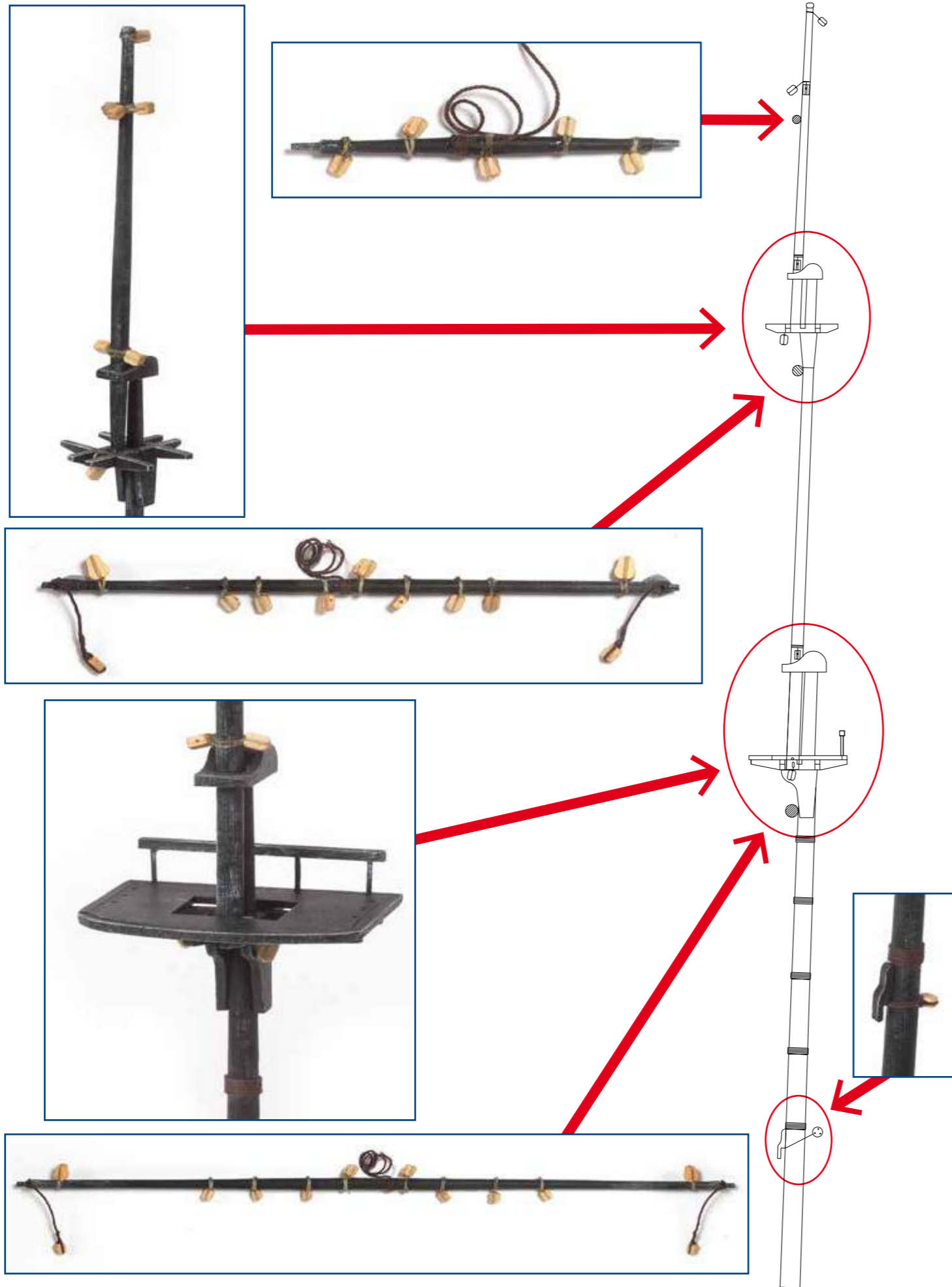

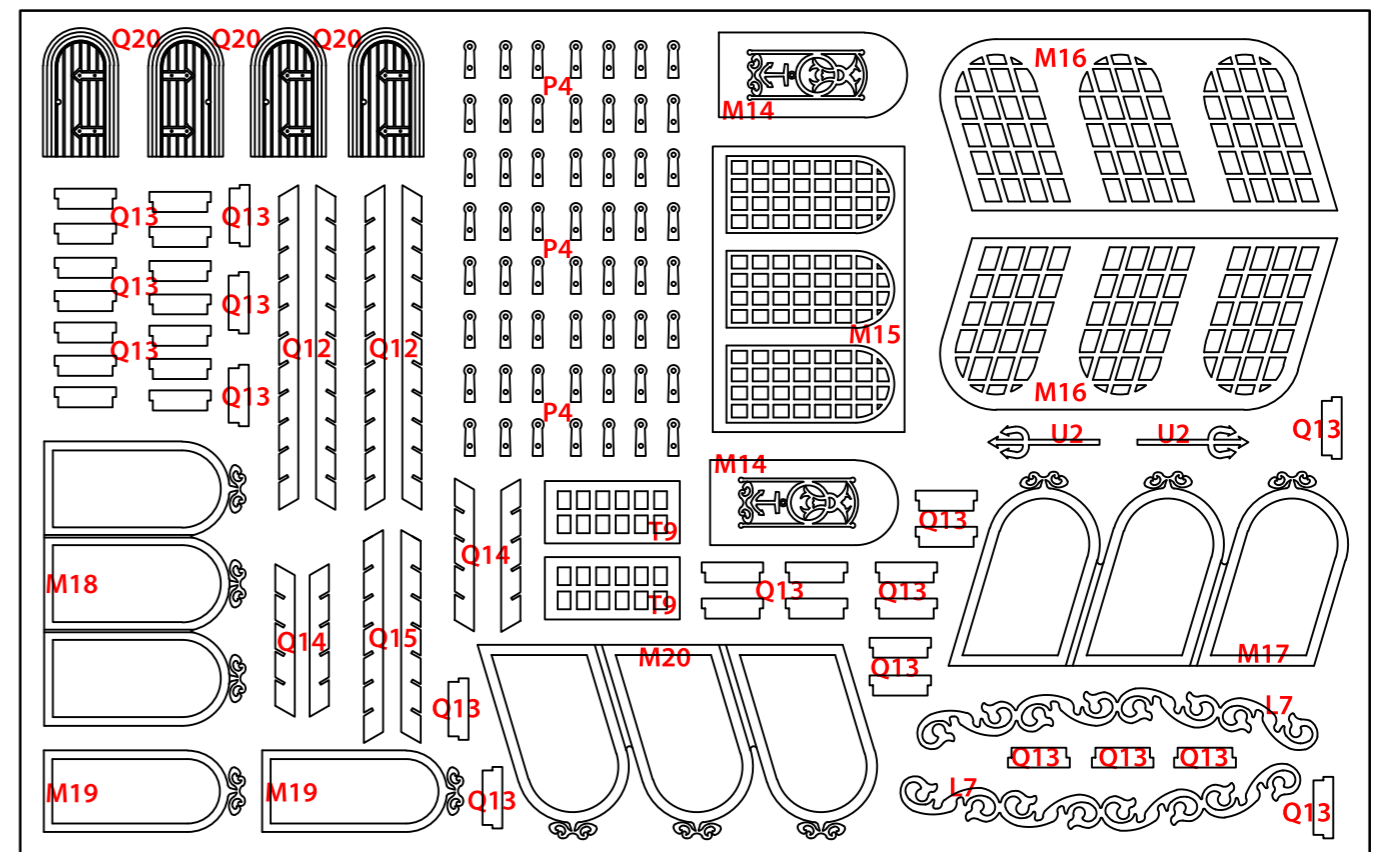
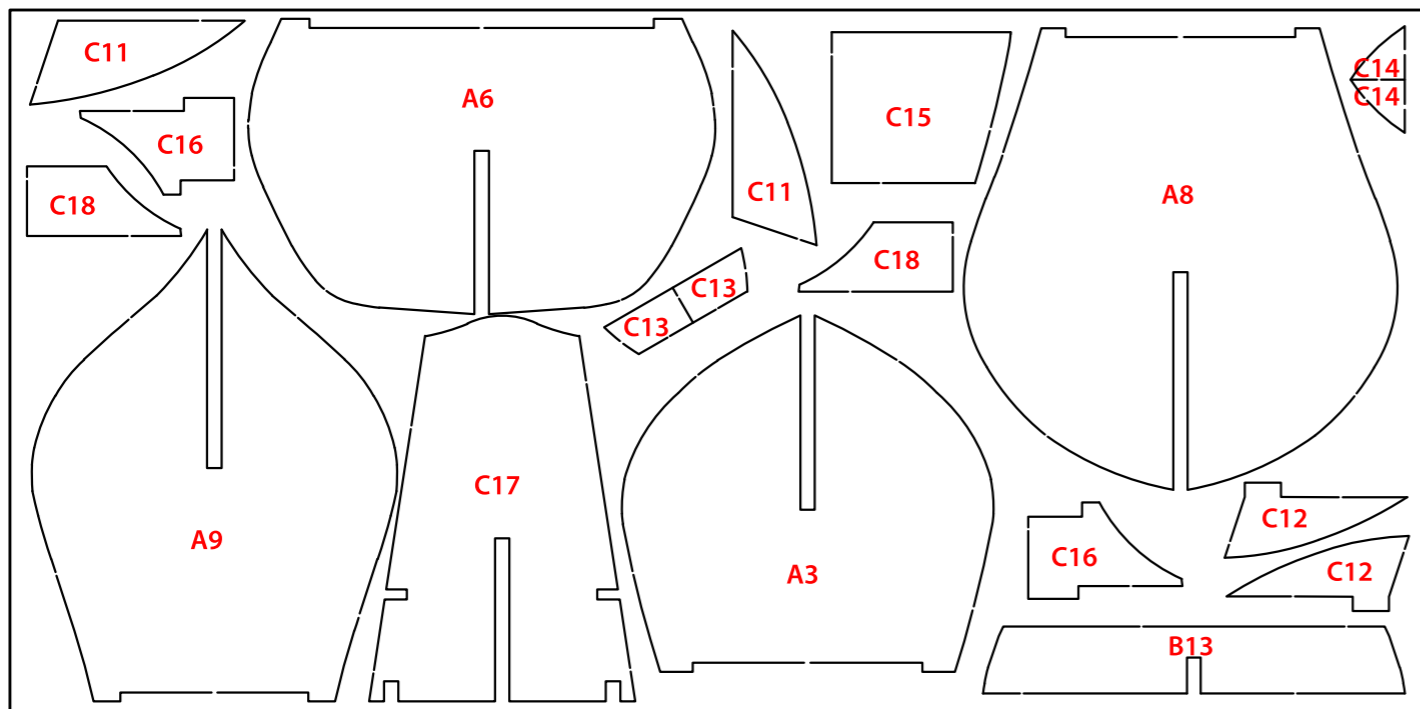
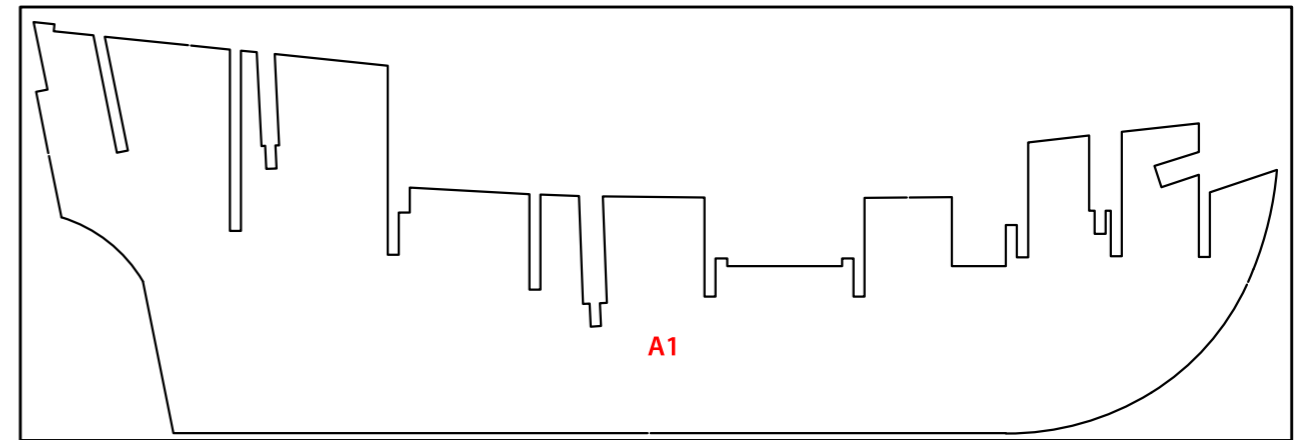
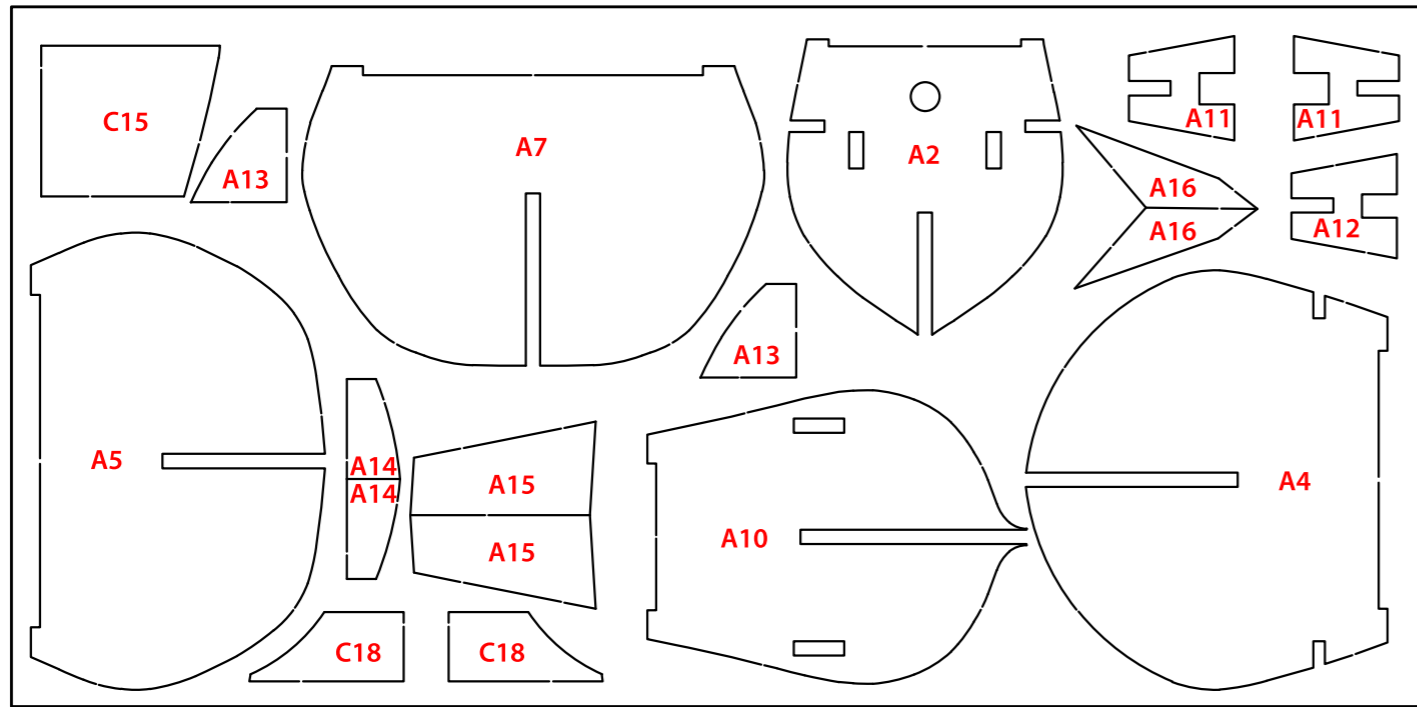

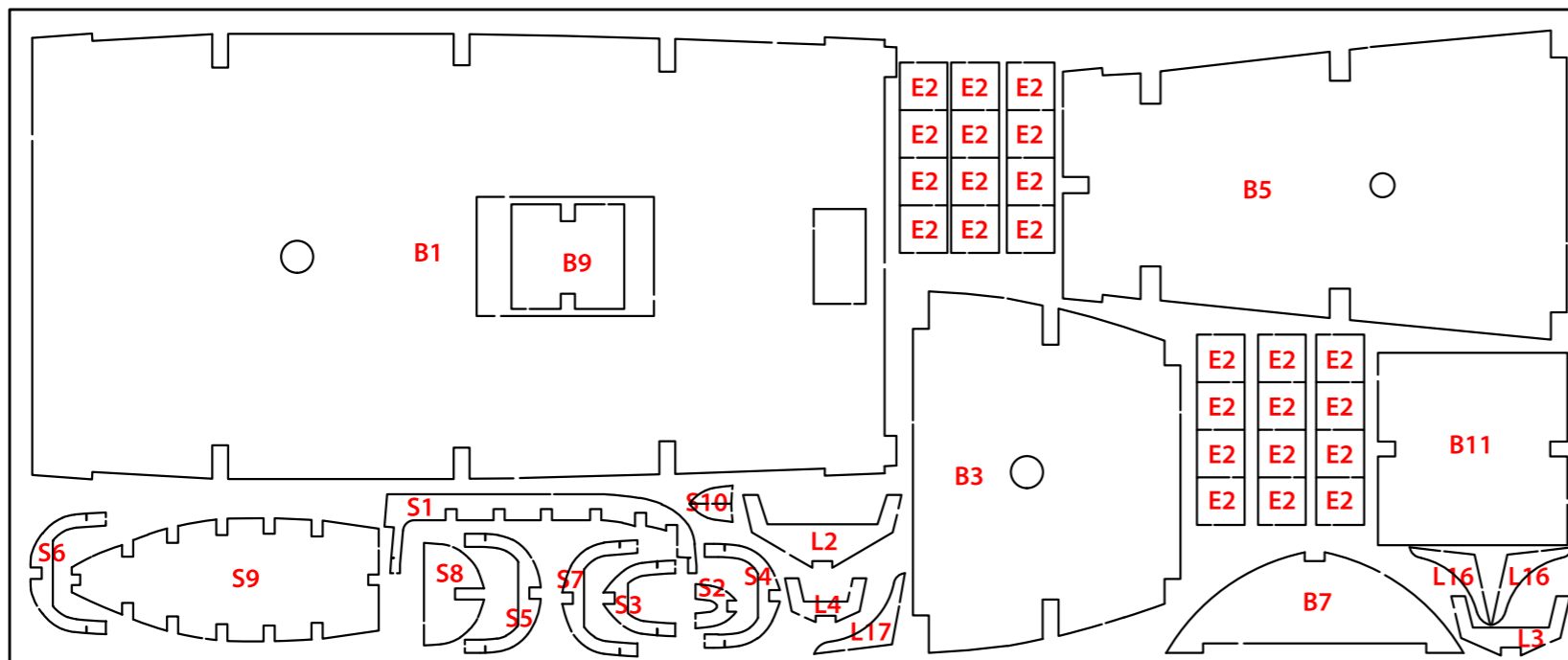

12012-4

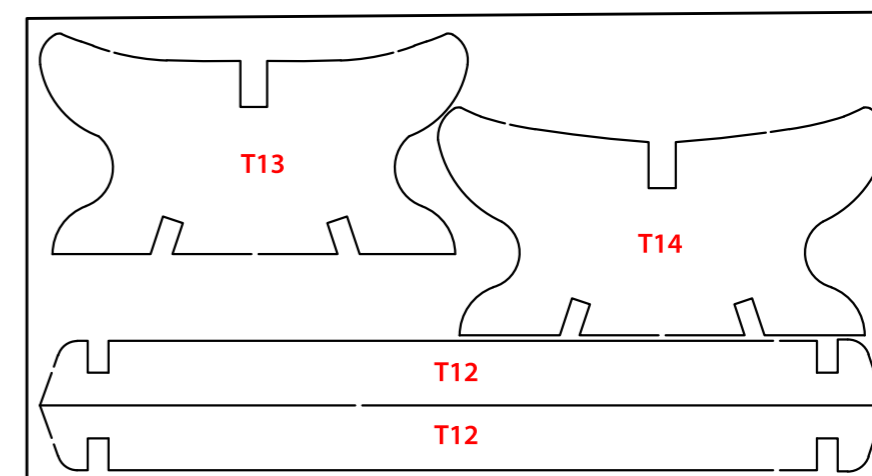

12012-8

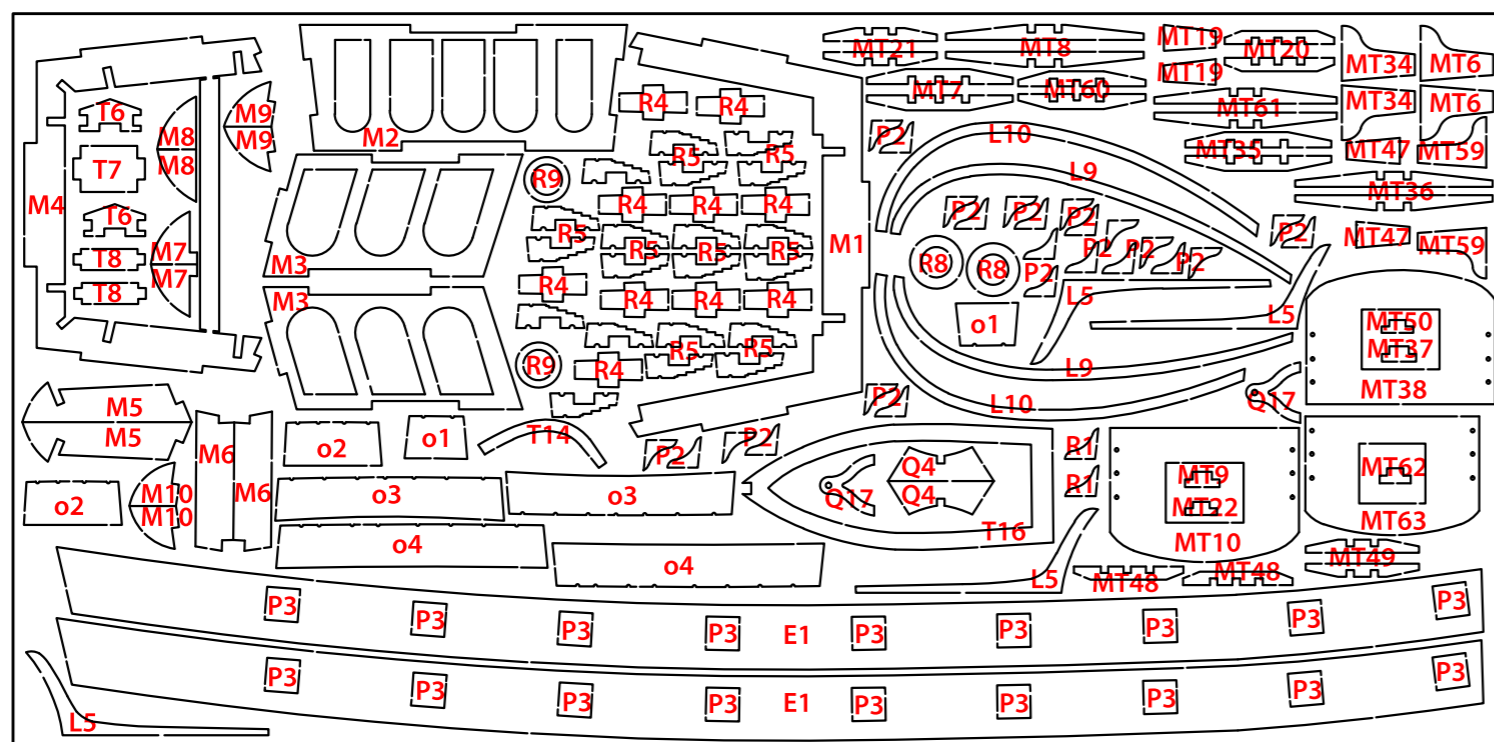

12012-6

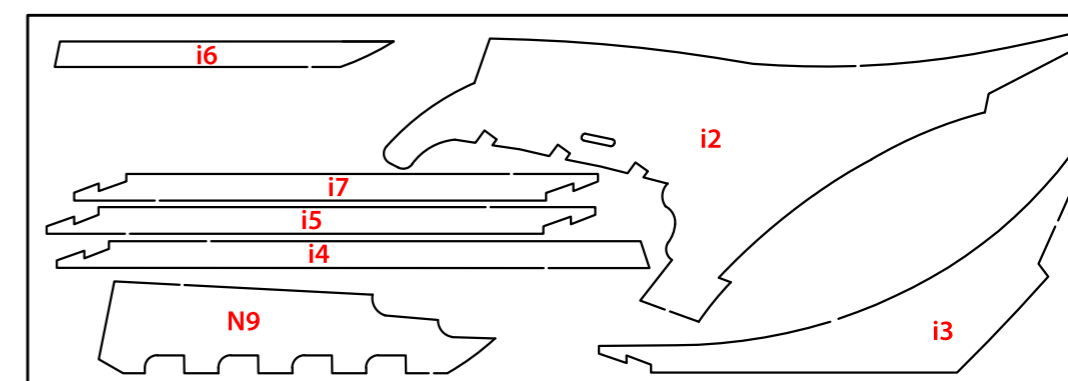

12012-7

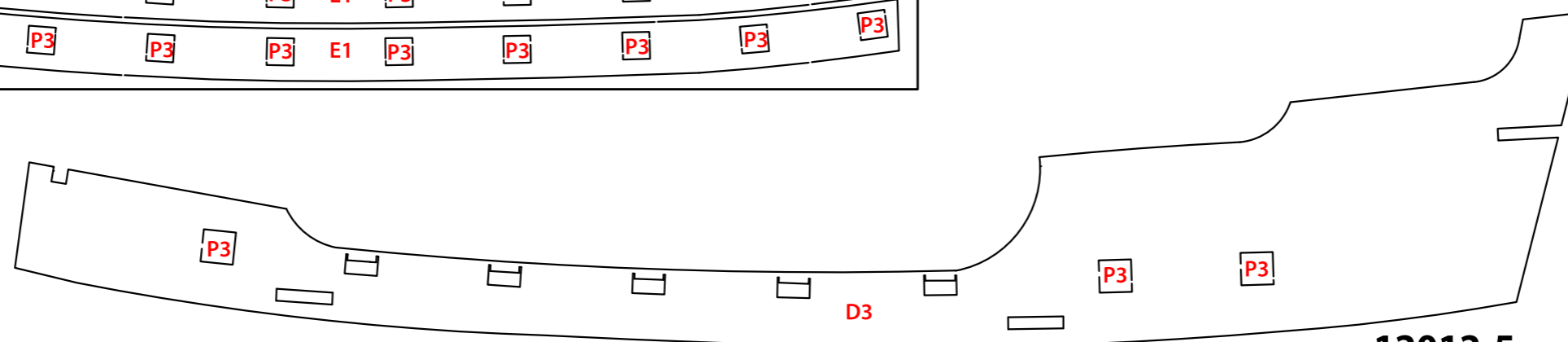

12012-5

OCCRE

CISNE NEGRO

Ref.12012

4

Planos de mástiles, velas y plantillas
Mast and sail plans and templates
Plans des mâts, voiles et bases
Piani degli alberi, vele e sagome
Pläne für bemastung und segel und schablonen



Cisne Negro

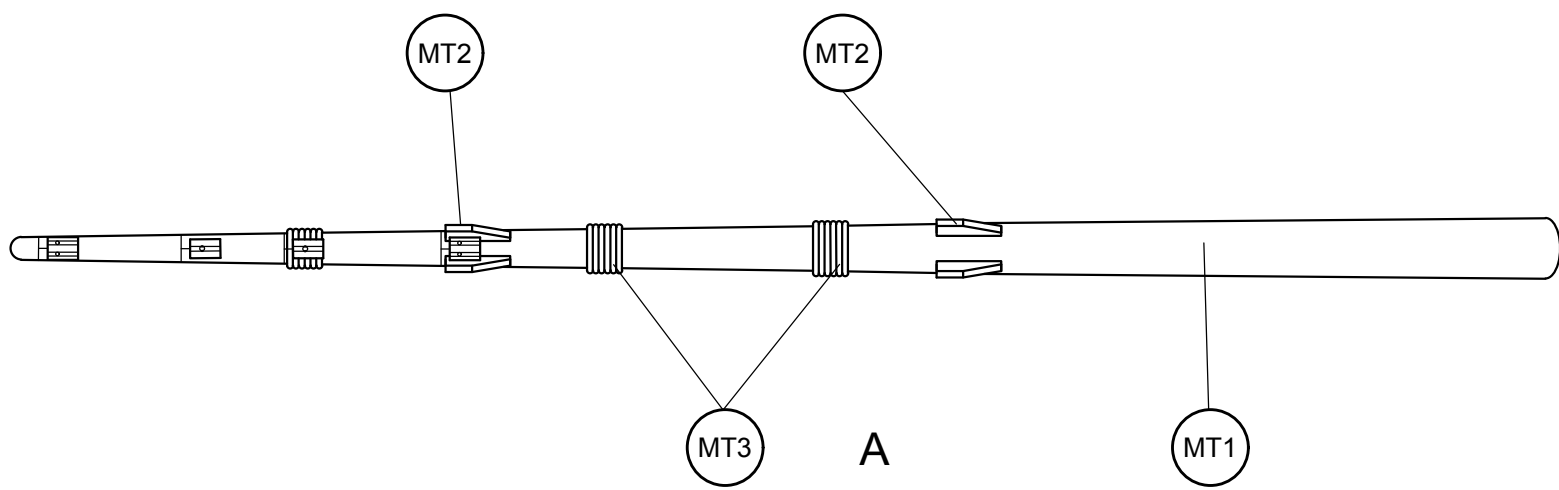
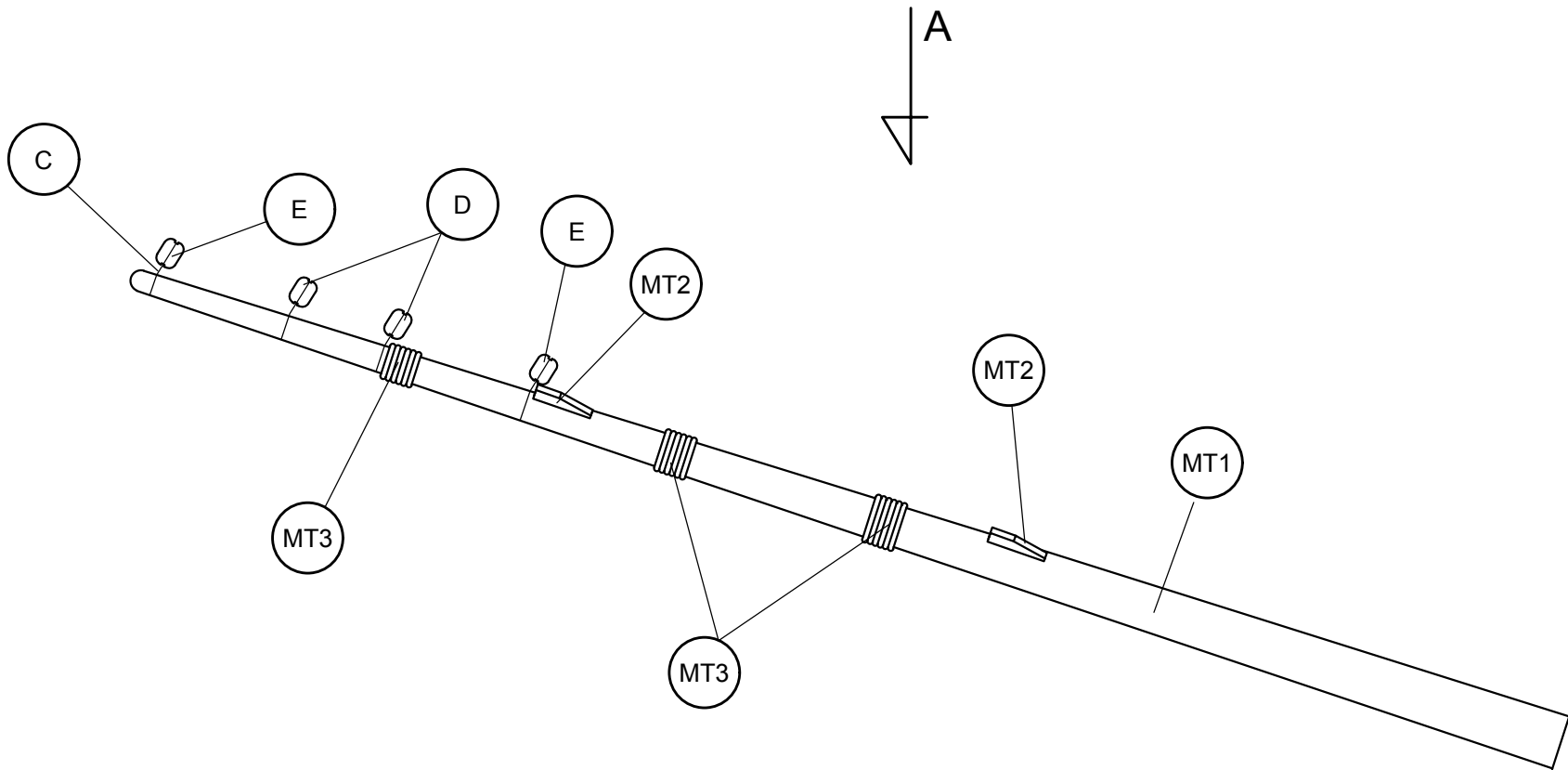
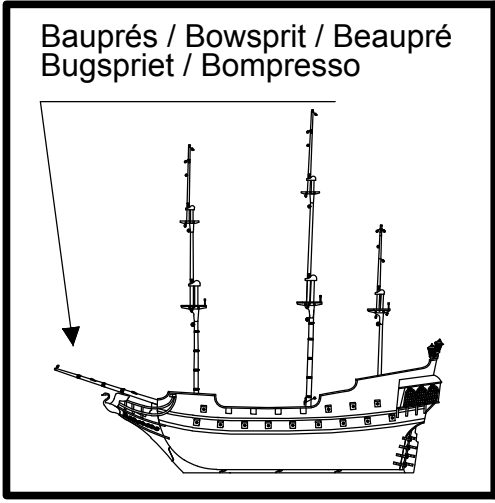

MT1	ø8x214	Tilo / Lime wood / Tilleul / Linde / Tiglio
MT2	2x2x8	Tilo / Lime wood / Tilleul / Linde / Tiglio
MT3	ø0,50x150	Hilo marrón / Brown thread / Fil brun /braunes Baumwollfaden / Filo marrone
C	ø0,15x100	Hilo crudo / Raw thread / Fil brut / Rohes Baumwollfaden / Filo crudo
D	4	Madera / Wood / Bois / Holz / Legno
E	4	Madera / Wood / Bois / Holz / Legno

Scale 1/1

B	D	E	F-G	H	J	K	M
Cáncamo Eyebolts Caviglia di ferro ad anello Tragöse Piton à oeil	Moton Blocks Bozzello Blockrolle Poulie	Cuadernal Double blocks Pastecca Block Poulie double	Vigota Dead eyes Bigotta Jungfernblock Cap de mouton	Anilla Rings Anello Öse Oeil	Cabilla Belaying Pins Caviglia Rundeisen Cheville	Vertello Trucks Bertocci Racktaublöcke Pomme de racage	Motón de violín Violin shaped block Bozzello di violino Blockrolle Geige Poulie de violon

Cisne Negro

Palo trinquete / Fore mast
Mât de misaine / Fockmast
Albero trinchetto

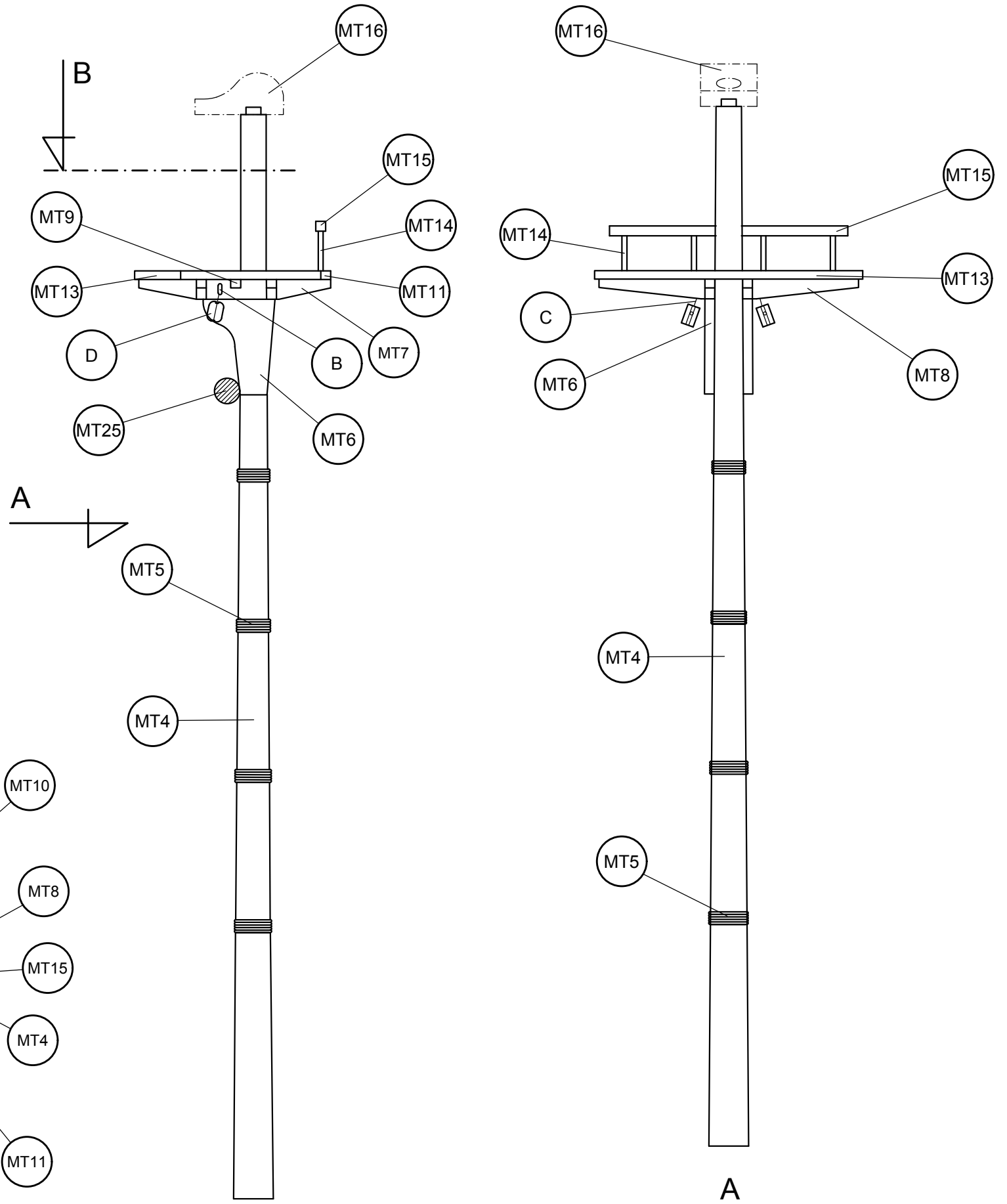
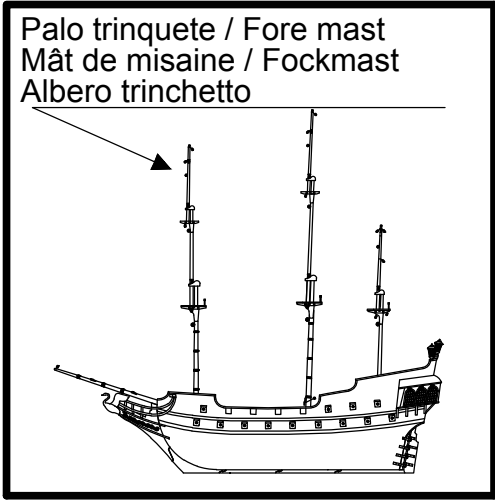

A

Scale 1/1

MT 4	ø8x220	Tilo / Lime wood / Tilleul / Linde / Tiglio	MT 12	2x2x28	Tilo / Lime wood / Tilleul / Linde / Tiglio
MT 5	ø0,50x150	Hilo marrón / Brown thread / Fil brun / braunes Baumwollfaden / Filo marrone	MT 13	2x2x60	Tilo / Lime wood / Tilleul / Linde / Tiglio
MT 6	Precortado / Precut / Prédécoupé / Vorgeschnitten / Pretagliatto	Tablero / Plywood / Planche / Sperrholz / Tavola	MT 14	ø1x10	Latón / Brass / Latón / Messing / Ottone
MT 7	Precortado / Precut / Prédécoupé / Vorgeschnitten / Pretagliatto	Tablero / Plywood / Planche / Sperrholz / Tavola	MT 15	2x2x48	Tilo / Lime wood / Tilleul / Linde / Tiglio
MT 8	Precortado / Precut / Prédécoupé / Vorgeschnitten / Pretagliatto	Tablero / Plywood / Planche / Sperrholz / Tavola	MT 16	Preformado / Preformed / Préformé / Vorgeformt / Preformato	Metal / Metal / Metal / Metall / Metallo
MT 9	Precortado / Precut / Prédécoupé / Vorgeschnitten / Pretagliatto	Tablero / Plywood / Planche / Sperrholz / Tavola	B	15	Latón / Brass / Latón / Messing / Ottone
MT 10	Precortado / Precut / Prédécoupé / Vorgeschnitten / Pretagliatto	Tablero / Plywood / Planche / Sperrholz / Tavola	C	ø0,15x100	Hilo crudo / Raw thread / Fil brut / Rohes Baumwollfaden / Filo crudo
MT 11	2x2x54	Tilo / Lime wood / Tilleul / Linde / Tiglio	D	4	Madera / Wood / Bois / Holz / Legno

Cisne Negro

Palo trinquete / Fore mast / Mât de misaine
Fockmast / Albero trinchetto

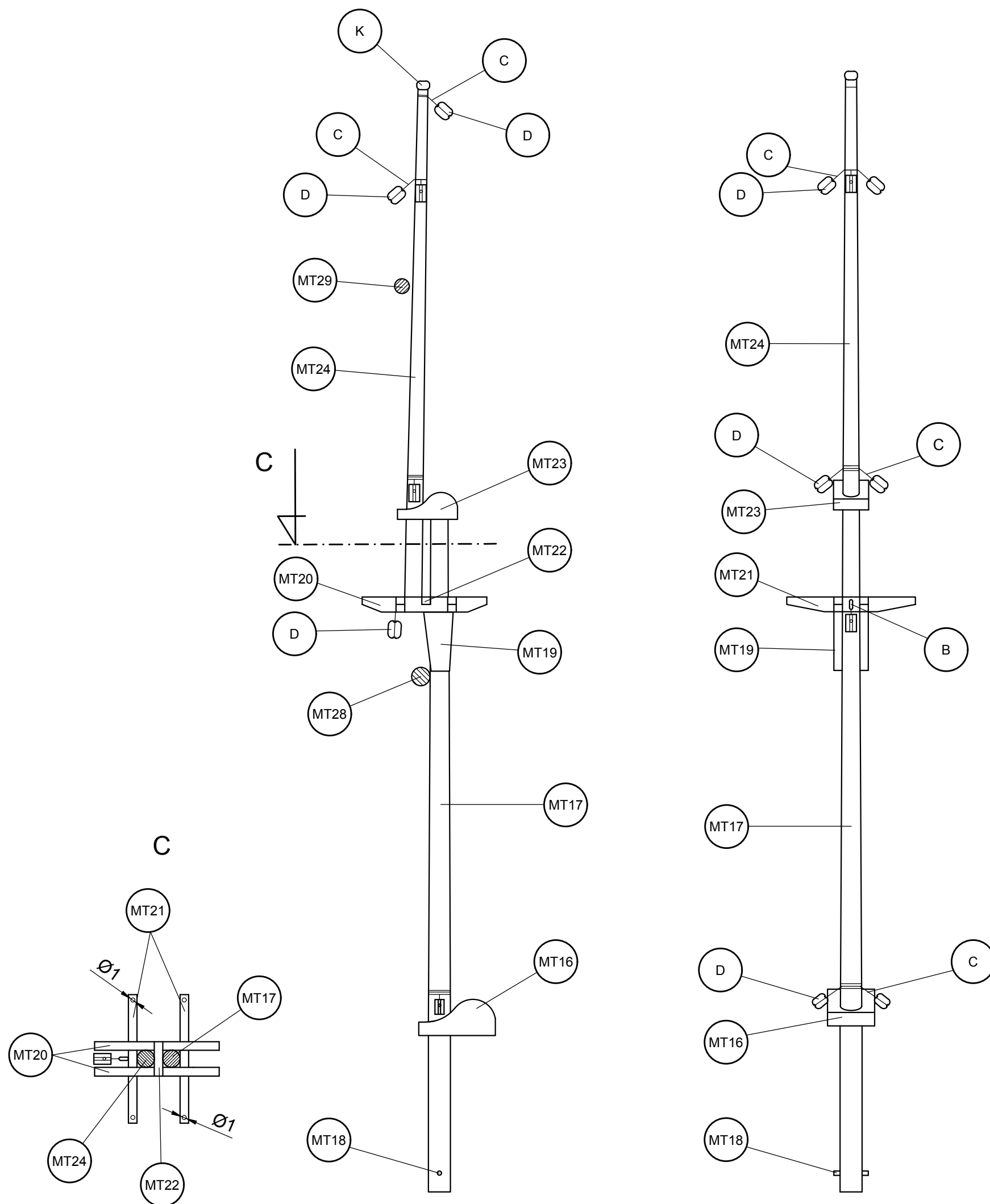

Scale 1/1

MT17	ø5x158	Tilo / Lime wood / Tilleul / Linde / Tiglio	MT23	Preformado / Preformed / Préformé / Vorgeformt / Preformato	Metal / Metal / Metal / Metall / Metallo
MT18	ø1x8	Latón / Brass / Latón / Messing / Ottone	MT24	ø4x121	Tilo / Lime wood / Tilleul / Linde / Tiglio
MT19	Precortado / Precut / Prédécoupé / Vorgeschnitten / Pretagliato	Tablero / Plywood / Planche / Sperrholz / Tavola	B	15	Latón / Brass / Latón / Messing / Ottone
MT20	Precortado / Precut / Prédécoupé / Vorgeschnitten / Pretagliato	Tablero / Plywood / Planche / Sperrholz / Tavola	C	ø0,15x100	Hilo crudo / Raw thread / Fil brut / Rohes Baumwollfaden / Filo crudo
MT21	Precortado / Precut / Prédécoupé / Vorgeschnitten / Pretagliato	Tablero / Plywood / Planche / Sperrholz / Tavola	D	4	Madera / Wood / Bois / Holz / Legno
MT22	Precortado / Precut / Prédécoupé / Vorgeschnitten / Pretagliato	Tablero / Plywood / Planche / Sperrholz / Tavola	K	ø3	Cristal / Glass / Verre / Glas / Cristallo

Cisne Negro

Palo trinquete / Fore mast / Mât de misaine
Fockmast / Albero trinchetto

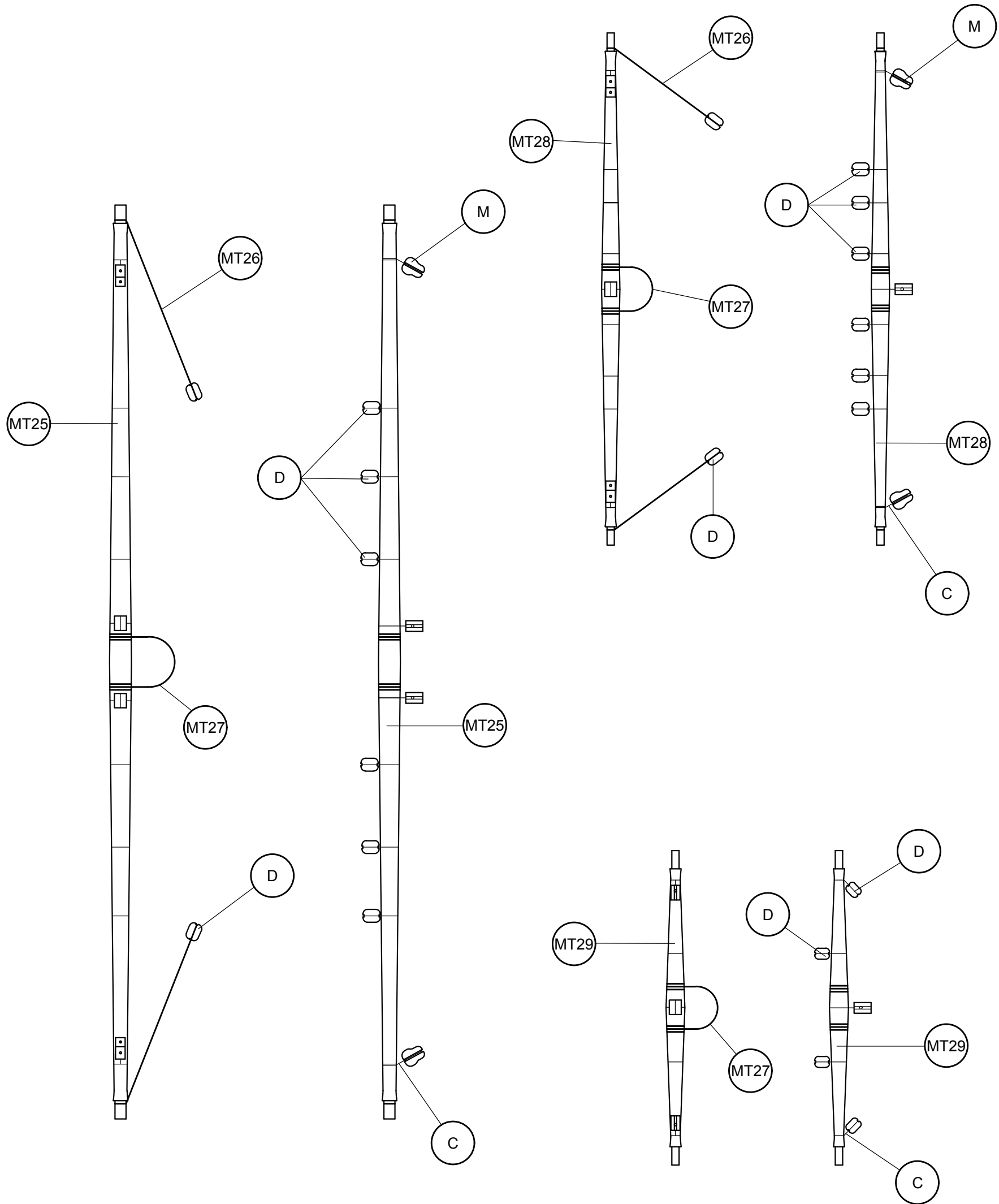

Scale 1/1

MT25	ø5x214	Tilo / Lime wood / Tilleul / Linde / Tiglio	MT29	ø4x74	Tilo / Lime wood / Tilleul / Linde / Tiglio
MT26	ø0,50x150	Hilo marrón / Brown thread / Fil brun/braunes Baumwollfaden / Filo marrone	C	ø0,15x100	Hilo crudo / Raw thread / Fil brut / Rohes Baumwollfaden / Filo crudo
MT27	ø0,50x150	Hilo marrón / Brown thread / Fil brun/braunes Baumwollfaden / Filo marrone	D	4	Madera / Wood / Bois / Holz / Legno
MT28	ø4x120	Tilo / Lime wood / Tilleul / Linde / Tiglio	M	5	Madera / Wood / Bois / Holz / Legno

Cisne Negro

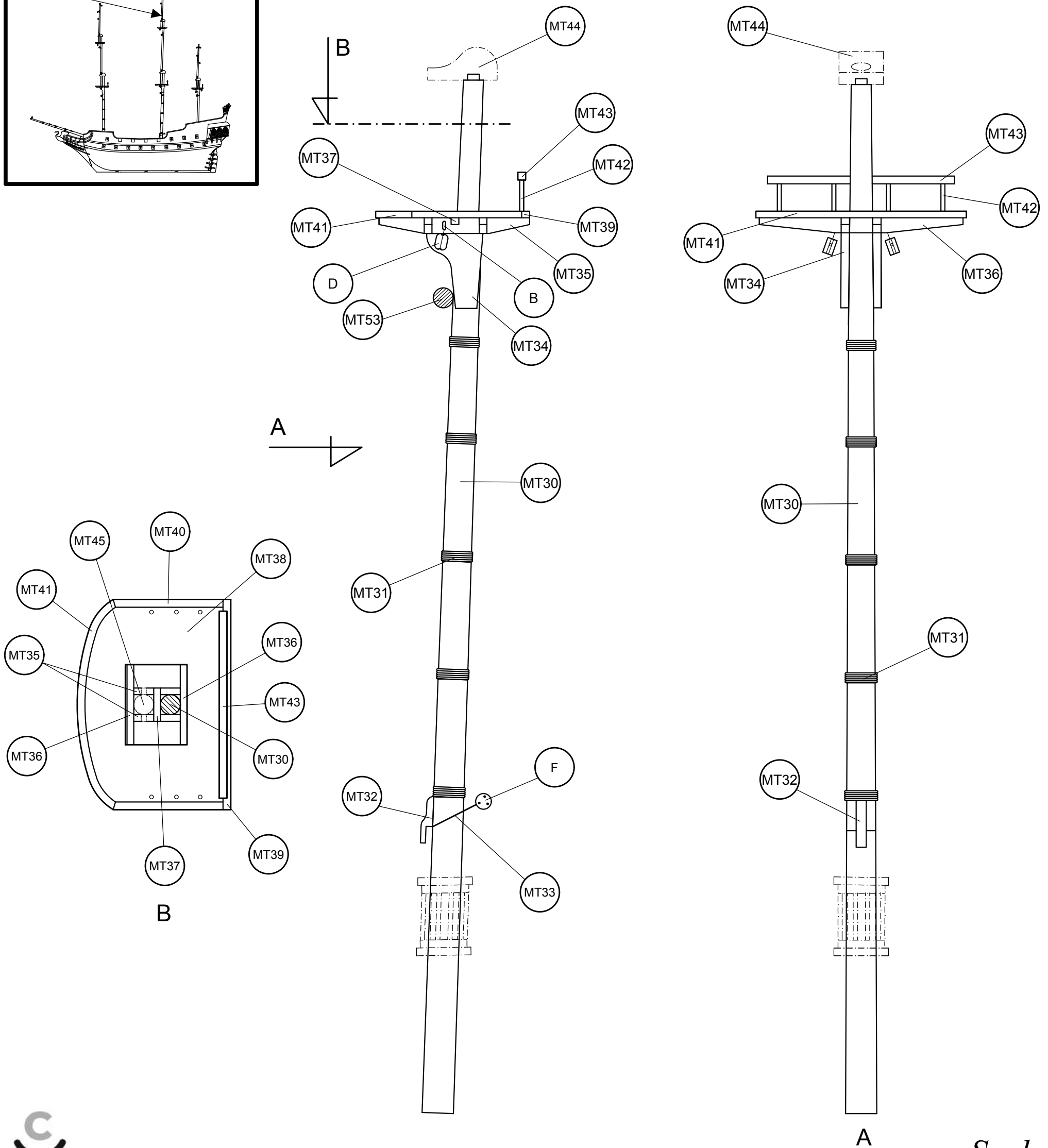
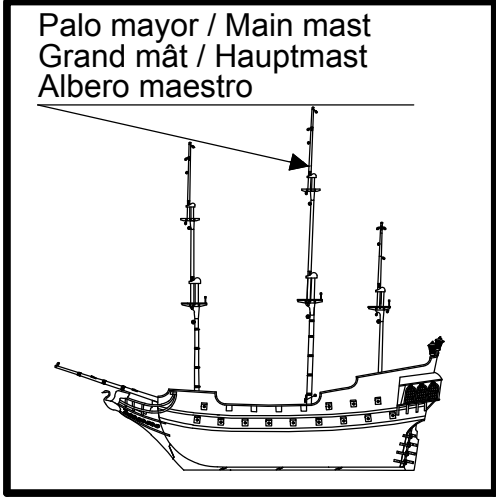

Scale 1/1

MT30	ø8x267	Tilo / Lime wood / Tilleul / Linde / Tiglio	MT40	2x2x28	Tilo / Lime wood / Tilleul / Linde / Tiglio
MT31	ø0,50x150	Hilo marrón / Brown thread / Fil brun / braunes Baumwollfaden / Filo marrone	MT41	2x2x60	Tilo / Lime wood / Tilleul / Linde / Tiglio
MT32	Preformado / Preformed / Préformé / Vorgeformt / Preformato	Metal / Metal / Metal / Metall / Metallo	MT42	ø1x10	Latón / Brass / Latón / Messing / Ottone
MT33	ø0,50x125	Hilo marrón / Brown thread / Fil brun / braunes Baumwollfaden / Filo marrone	MT43	2x2x48	Tilo / Lime wood / Tilleul / Linde / Tiglio
MT34	Precortado / Precut / Prédécoupé / Vorgeschnitten / Pretagliato	Tablero / Plywood / Planche / Sperrholz / Tavola	MT44	Preformado / Preformed / Préformé / Vorgeformt / Preformato	Metal / Metal / Metal / Metall / Metallo
MT35	Precortado / Precut / Prédécoupé / Vorgeschnitten / Pretagliato	Tablero / Plywood / Planche / Sperrholz / Tavola	B	15	Latón / Brass / Latón / Messing / Ottone
MT36	Precortado / Precut / Prédécoupé / Vorgeschnitten / Pretagliato	Tablero / Plywood / Planche / Sperrholz / Tavola	C	ø0,15x100	Hilo crudo / Raw thread / Fil brut / Rohes Baumwollfaden / Filo crudo
MT37	Precortado / Precut / Prédécoupé / Vorgeschnitten / Pretagliato	Tablero / Plywood / Planche / Sperrholz / Tavola	D	4	Madera / Wood / Bois / Holz / Legno
MT38	Precortado / Precut / Prédécoupé / Vorgeschnitten / Pretagliato	Tablero / Plywood / Planche / Sperrholz / Tavola	F	ø4	Madera / Wood / Bois / Holz / Legno
MT39	2x2x54	Tilo / Lime wood / Tilleul / Linde / Tiglio			

Cisne Negro

Palo mayor / Main mast / Grand mât

Albero maestro / Hauptmast

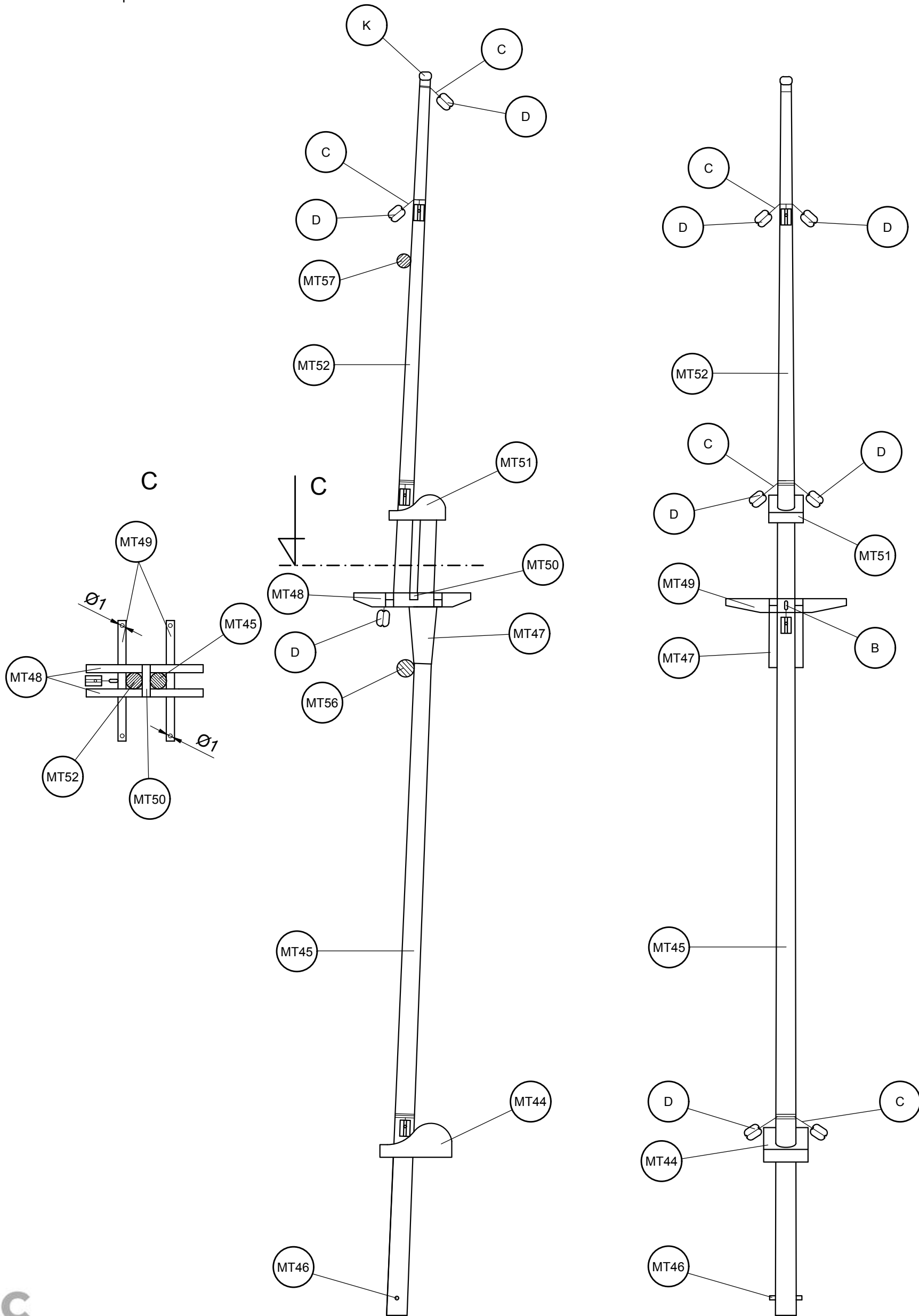

Scale 1/1

MT45	∅5x200	Tilo / Lime wood / Tilleul / Linde / Tiglio	MT51	Preformado / Preformed/ Préformé / Vorgeformt / Preformato	Metal / Metal / Metal / Metall / Metallo
MT46	∅1x8	Latón / Brass / Latón / Messing / Ottone	MT52	∅4x131	Tilo / Lime wood / Tilleul / Linde / Tiglio
MT47	Precortado / Precut / Prédécoupé / Vorgeschnitten / Pretagliatto	Tablero / Plywood / Planche / Sperrholz / Tavola	B	15	Latón / Brass / Latón / Messing / Ottone
MT48	Precortado / Precut / Prédécoupé / Vorgeschnitten / Pretagliatto	Tablero / Plywood / Planche / Sperrholz / Tavola	C	∅0,15x100	Hilo crudo / Raw thread / Fil brut / Rohes Baumwollfaden / Filo crudo
MT49	Precortado / Precut / Prédécoupé / Vorgeschnitten / Pretagliatto	Tablero / Plywood / Planche / Sperrholz / Tavola	D	4	Madera / Wood / Bois / Holz / Legno
MT50	Precortado / Precut / Prédécoupé / Vorgeschnitten / Pretagliatto	Tablero / Plywood / Planche / Sperrholz / Tavola	K	∅3	Cristal / Glass / Verre / Glas / Cristallo

Cisne Negro

Palo mayor / Main mast / Grand mât
 Albero maestro / Hauptmast

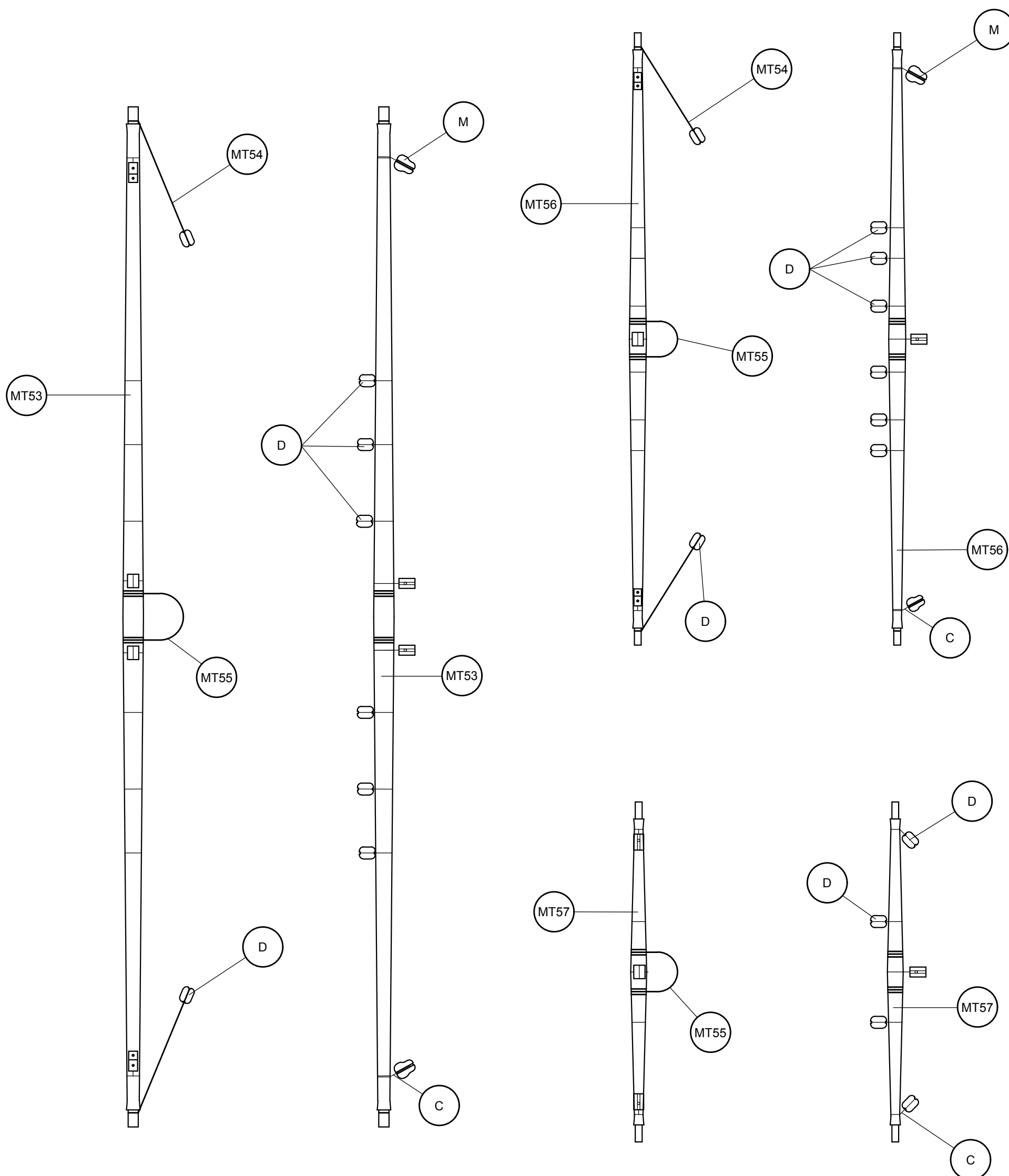

Scale 1/1

MT53	ø5x257	Tilo / Lime wood / Tilleul / Linde / Tiglio	MT57	ø4x86	Tilo / Lime wood / Tilleul / Linde / Tiglio
MT54	ø0,50x150	Hilo marrón / Brown thread / Fil brun/braunes Baumwollfaden / Filo marrone	C	ø0,15x100	Hilo crudo / Raw thread / Fil brut / Rohes Baumwollfaden / Filo crudo
MT55	ø0,50x150	Hilo marrón / Brown thread / Fil brun/braunes Baumwollfaden / Filo marrone	D	4	Madera / Wood / Bois / Holz / Legno
MT56	ø4x154	Tilo / Lime wood / Tilleul / Linde / Tiglio	M	5	Madera / Wood / Bois / Holz / Legno

Cisne Negro

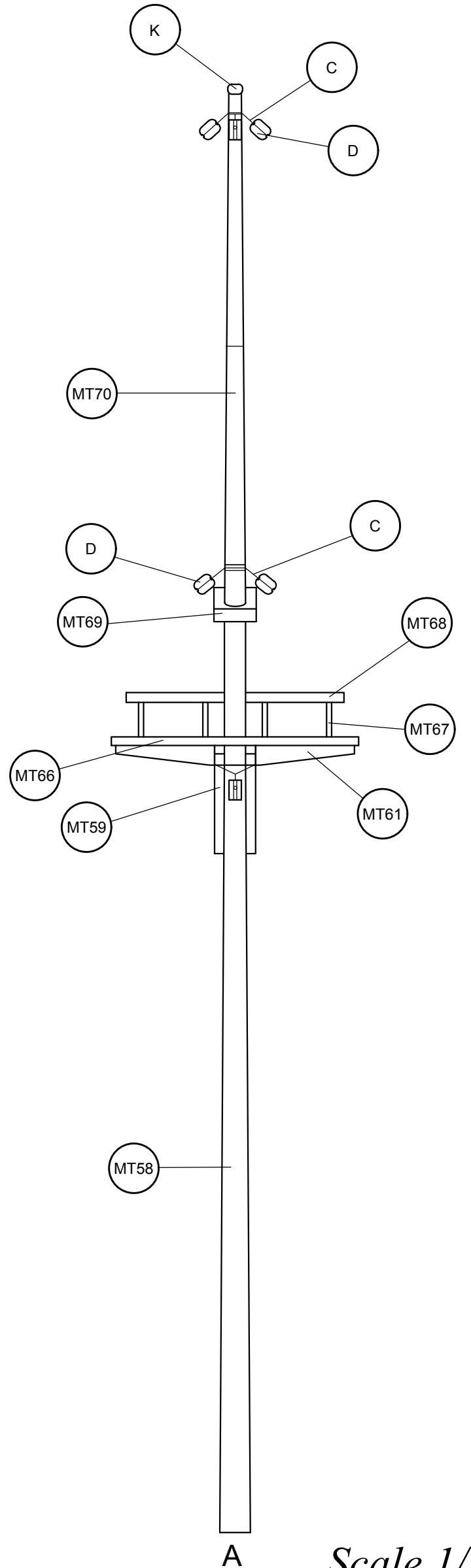
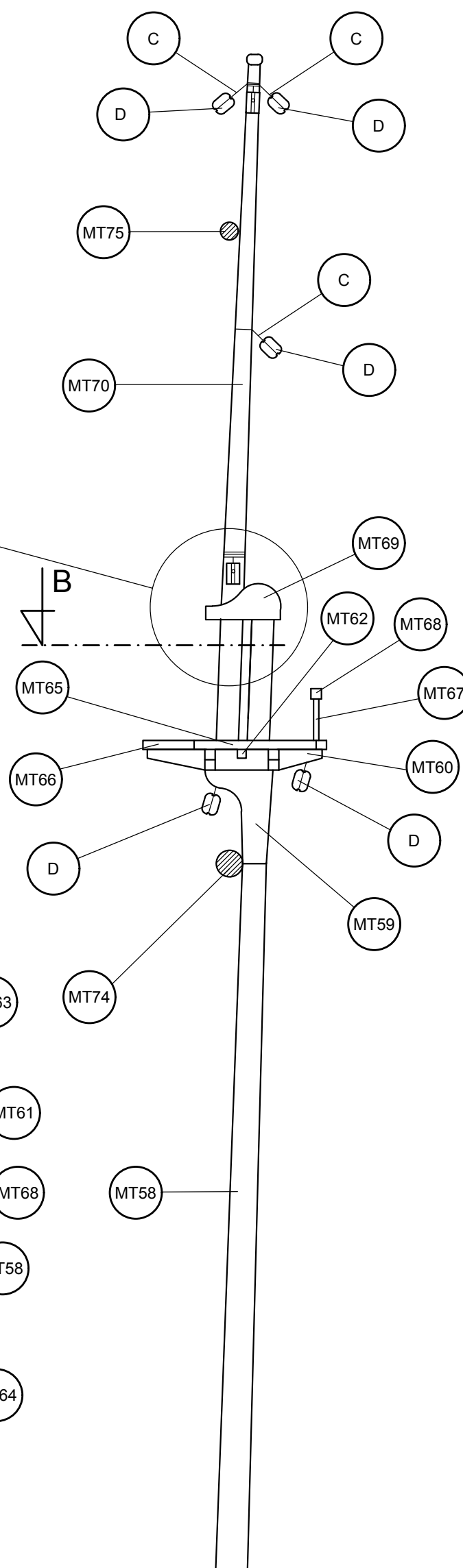
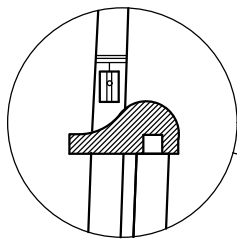

Scale 1/1

MT58	ø6x187	Tilo / Lime wood / Tilleul / Linde / Tiglio	MT67	ø1x10	Latón / Brass / Latón / Messing / Ottone
MT59	Precortado / Precut / Prédécoupé / Vorgeschnitten / Pretagliato	Tablero / Plywood / Planche / Sperrholz / Tavola	MT68	2x2x44	Tilo / Lime wood / Tilleul / Linde / Tiglio
MT60	Precortado / Precut / Prédécoupé / Vorgeschnitten / Pretagliato	Tablero / Plywood / Planche / Sperrholz / Tavola	MT69	Preformado / Preformed / Préformé / Vorgeformt / Preformato	Metal / Metal / Metal / Metall / Metallo
MT61	Precortado / Precut / Prédécoupé / Vorgeschnitten / Pretagliato	Tablero / Plywood / Planche / Sperrholz / Tavola	MT70	ø4x136	Tilo / Lime wood / Tilleul / Linde / Tiglio
MT62	Precortado / Precut / Prédécoupé / Vorgeschnitten / Pretagliato	Tablero / Plywood / Planche / Sperrholz / Tavola	MT71	ø1x8	Latón / Brass / Latón / Messing / Ottone
MT63	Precortado / Precut / Prédécoupé / Vorgeschnitten / Pretagliato	Tablero / Plywood / Planche / Sperrholz / Tavola	C	ø0,15x100	Hilo crudo / Raw thread / Fil brut / Rohes Baumwollfaden / Filo crudo
MT64	2x2x50	Tilo / Lime wood / Tilleul / Linde / Tiglio	D	4	Madera / Wood / Bois / Holz / Legno
MT65	2x2x26	Tilo / Lime wood / Tilleul / Linde / Tiglio	K	ø3	Cristal / Glass / Verre / Glas / Cristallo
MT66	2x2x56	Tilo / Lime wood / Tilleul / Linde / Tiglio			

Cisne Negro

Palo mesana/ Mizze mast / Mât d'artimon
 Albero mezzana / Besanmast

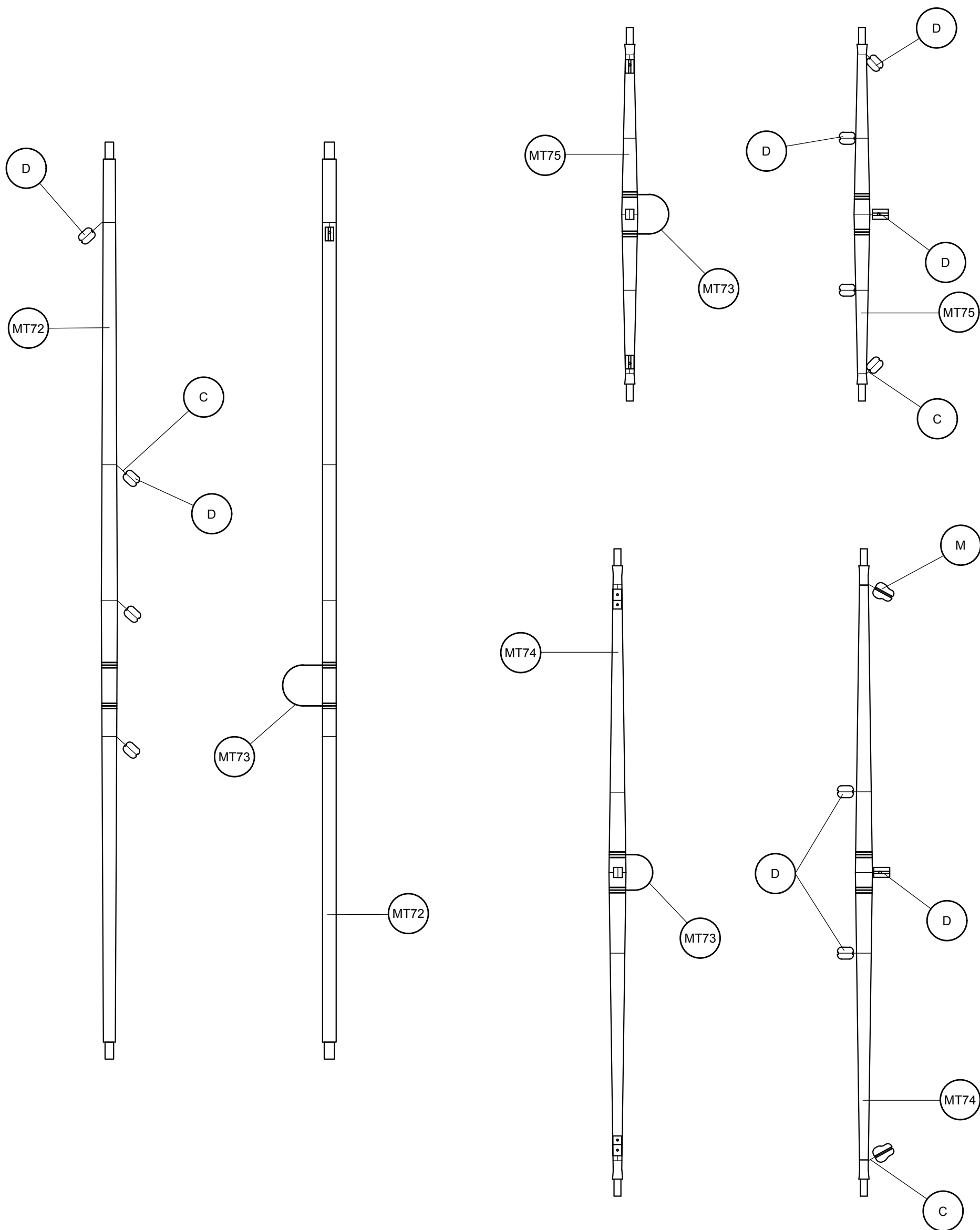

Scale 1/1

MT72	ø4x231	Tilo / Lime wood / Tilleul / Linde / Tiglio	C	ø0,15x100	Hilo crudo / Raw thread / Fil brut / Rohes Baumwollfaden / Filo crudo
MT73	ø0,50x150	Hilo marrón / Brown thread / Fil brun / braunes Baumwollfaden / Filo marrone	D	4	Madera / Wood / Bois / Holz / Legno
MT74	ø4x163	Tilo / Lime wood / Tilleul / Linde / Tiglio	M	5	Madera / Wood / Bois / Holz / Legno
MT75	ø4x94	Tilo / Lime wood / Tilleul / Linde / Tiglio			

Cisne Negro

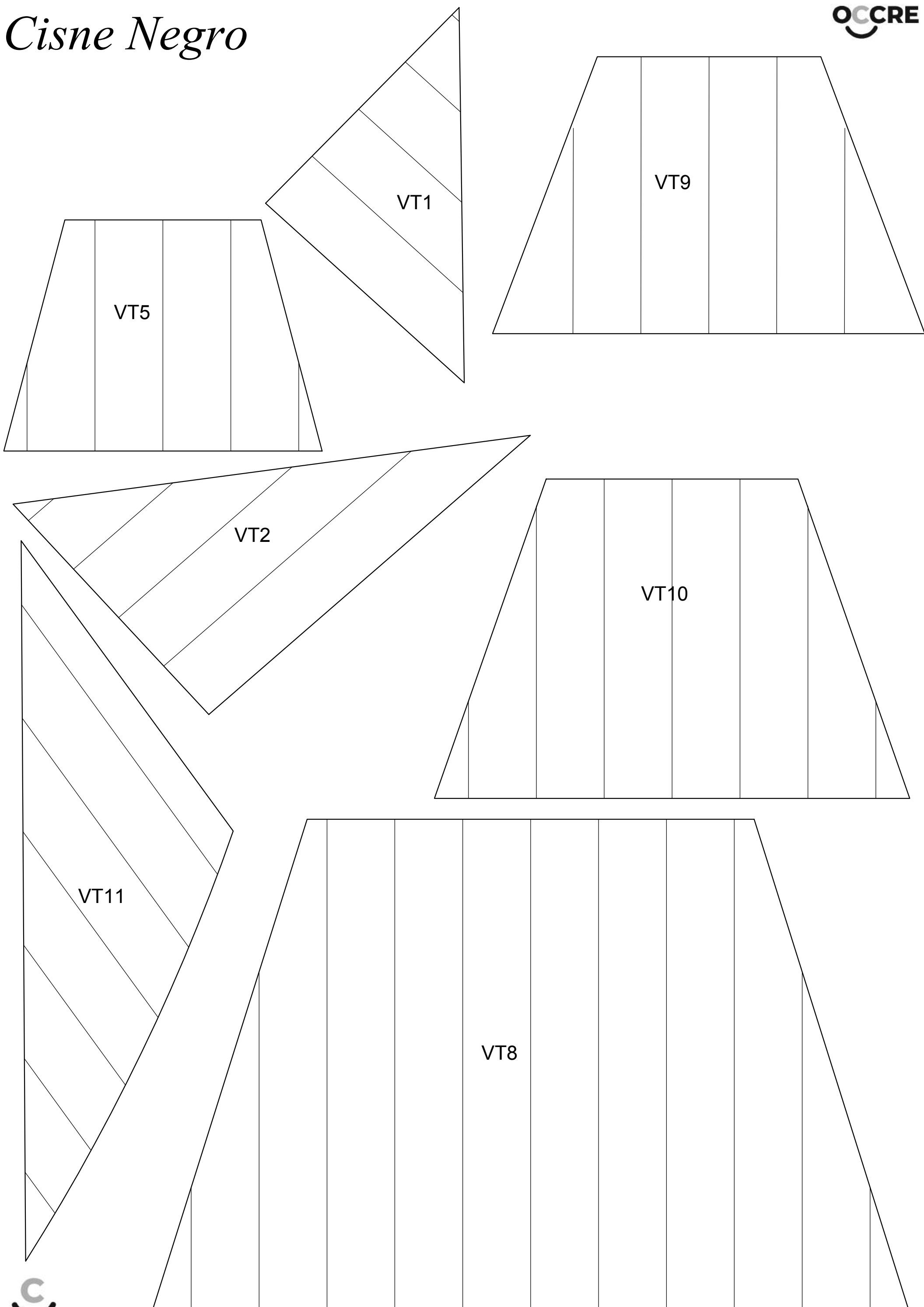

VT7

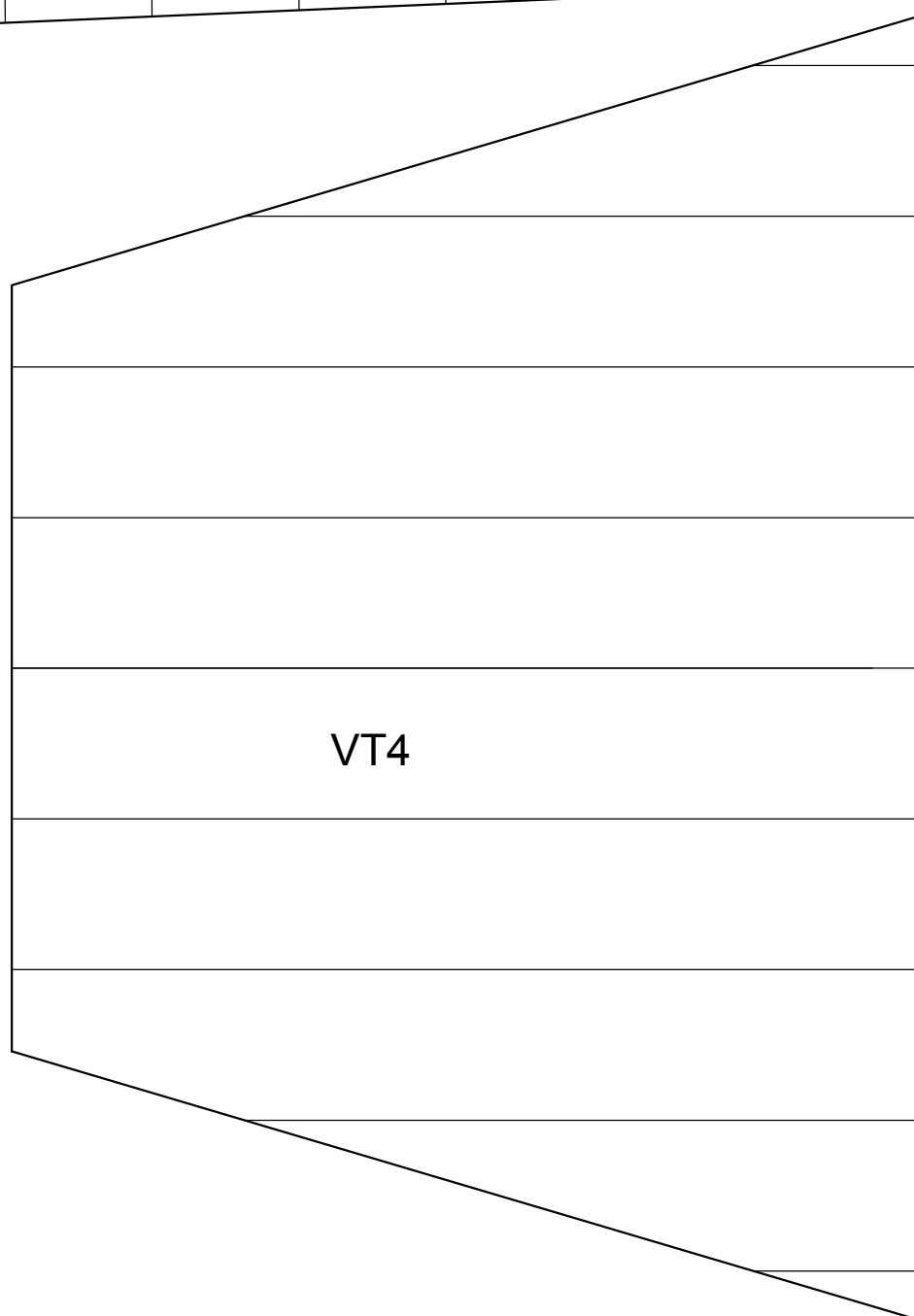
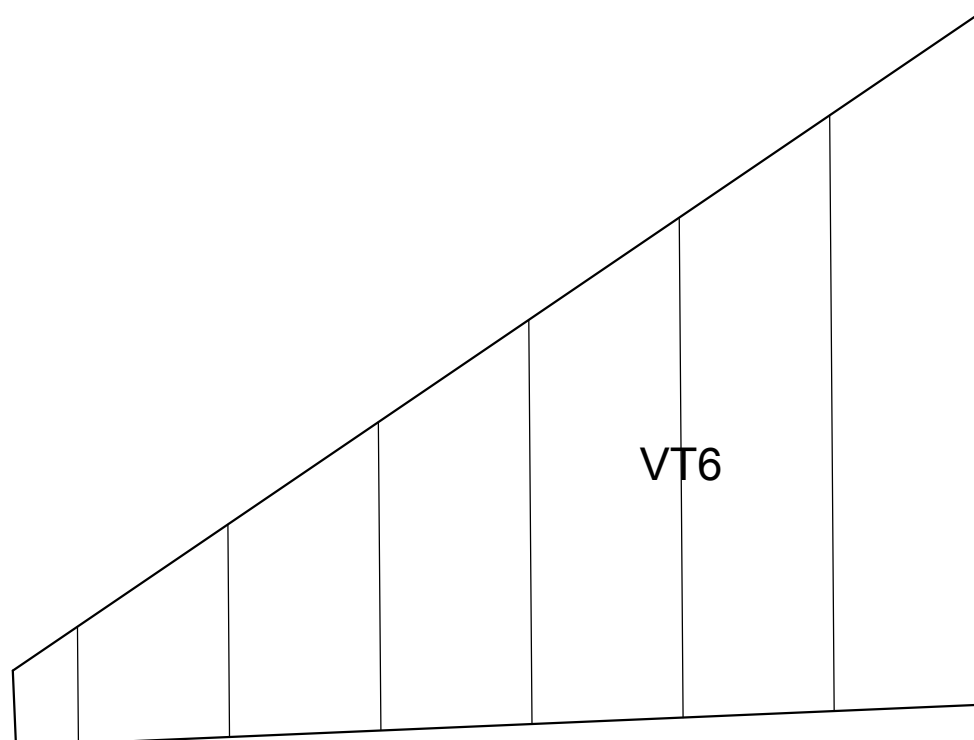

				VT3						
--	--	--	--	-----	--	--	--	--	--	--

Cisne Negro

PL-01

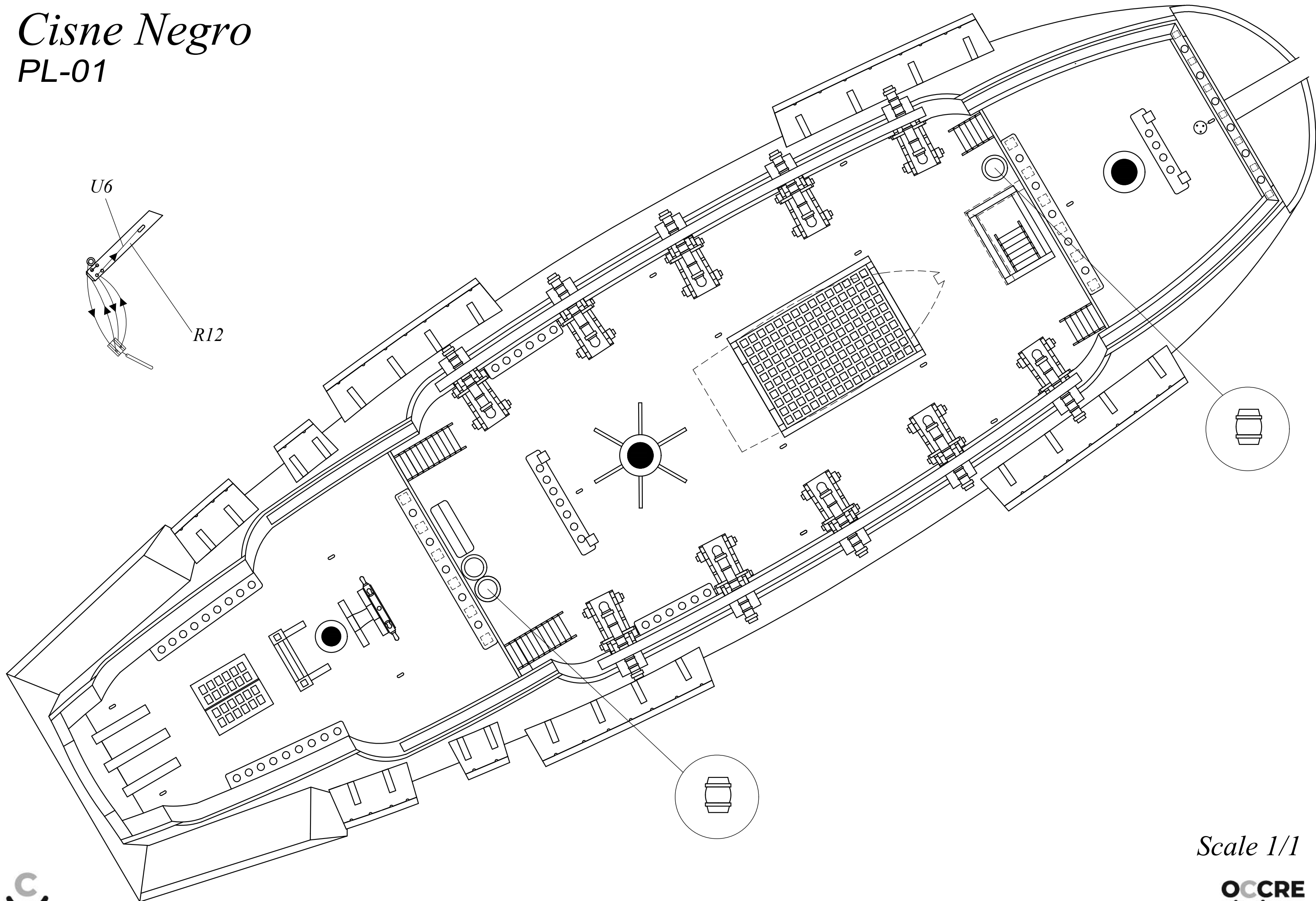

Scale 1/1



OCCRE

CISNE NEGRO

Ref.12012

5

Planos de jarcia
Rigging plans
Plans des gréements
Piani delle sartie
Pläne der takelung



Cisne Negro

OCCRE

A

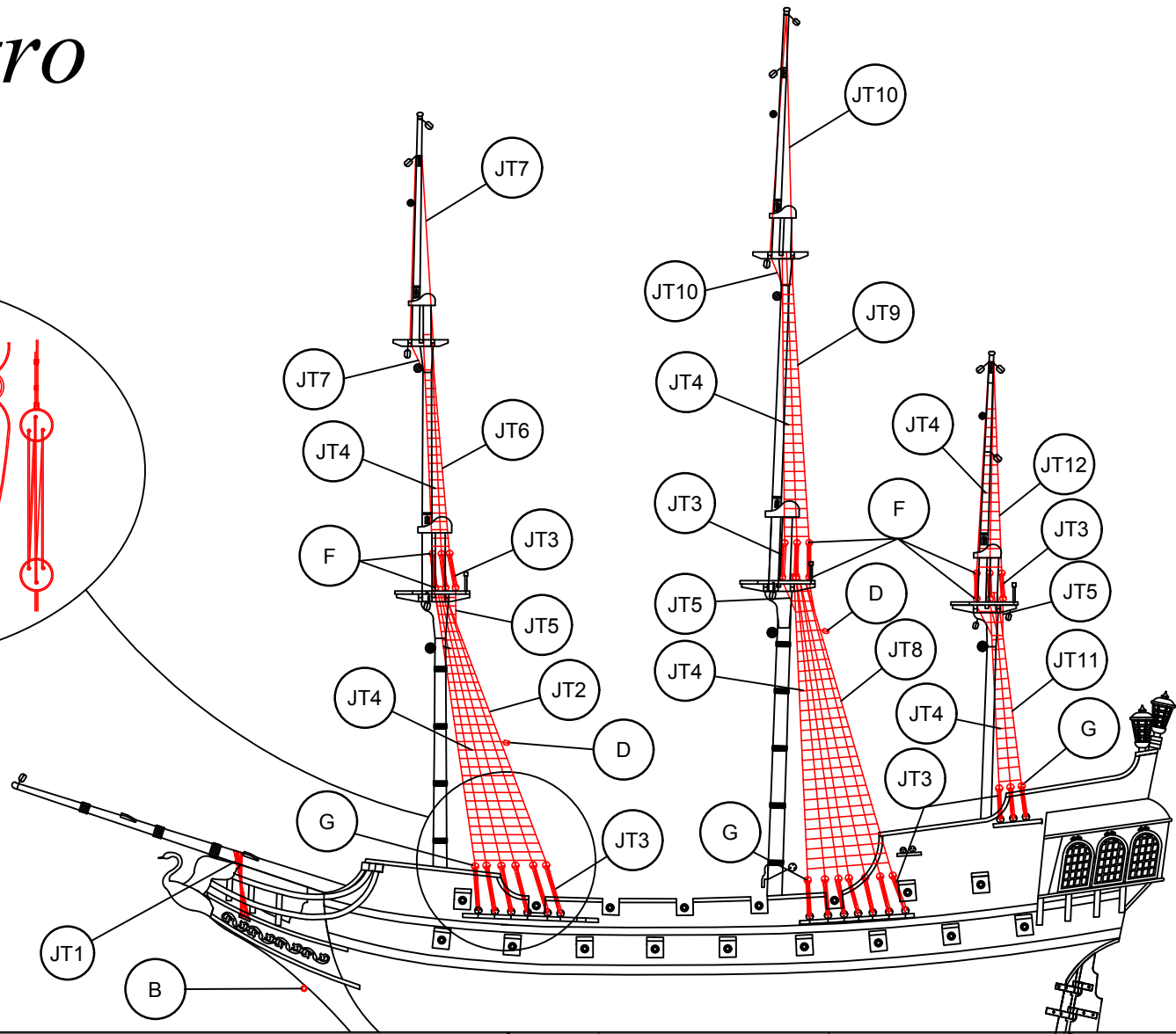
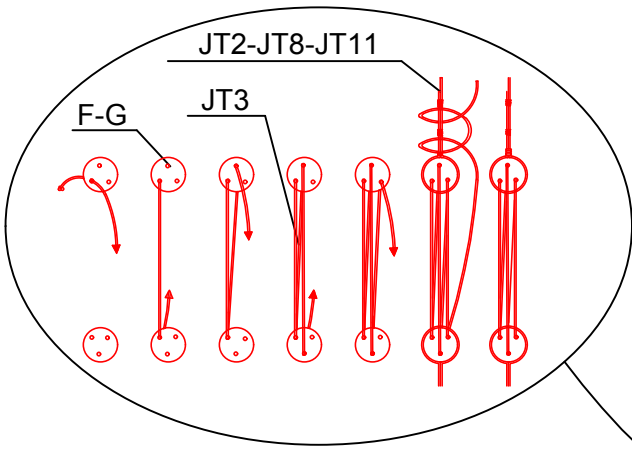

JT1	ø0,50x200	Hilo marrón / Brown thread / Fil brun /braunes Baumwollfaden / Filo marrone	JT9	ø0,50x450	Hilo marrón / Brown thread / Fil brun /braunes Baumwollfaden / Filo marrone
JT2	ø0,50x500	Hilo marrón / Brown thread / Fil brun /braunes Baumwollfaden / Filo marrone	JT10	ø0,50x400	Hilo marrón / Brown thread / Fil brun /braunes Baumwollfaden / Filo marrone
JT3	ø0,15x200	Hilo crudo / Raw thread / Fil brut / Rohes Baumwollfaden / Filo crudo	JT11	ø0,50x425	Hilo marrón / Brown thread / Fil brun /braunes Baumwollfaden / Filo marrone
JT4	ø0,15x100	Hilo marrón / Brown thread / Fil brun /braunes Baumwollfaden / Filo marrone	JT12	ø0,50x375	Hilo marrón / Brown thread / Fil brun /braunes Baumwollfaden / Filo marrone
JT5	ø0,50x175	Hilo marrón / Brown thread / Fil brun /braunes Baumwollfaden / Filo marrone	B	15	Latón / Brass / Latón / Messing / Ottone
JT6	ø0,50x350	Hilo marrón / Brown thread / Fil brun /braunes Baumwollfaden / Filo marrone	D	4	Madera / Wood / Bois / Holz / Legno
JT7	ø0,50x300	Hilo marrón / Brown thread / Fil brun /braunes Baumwollfaden / Filo marrone	F	ø4	Madera / Wood / Bois / Holz / Legno
JT8	ø0,50x650	Hilo marrón / Brown thread / Fil brun /braunes Baumwollfaden / Filo marrone	G	ø5	Madera / Wood / Bois / Holz / Legno

B

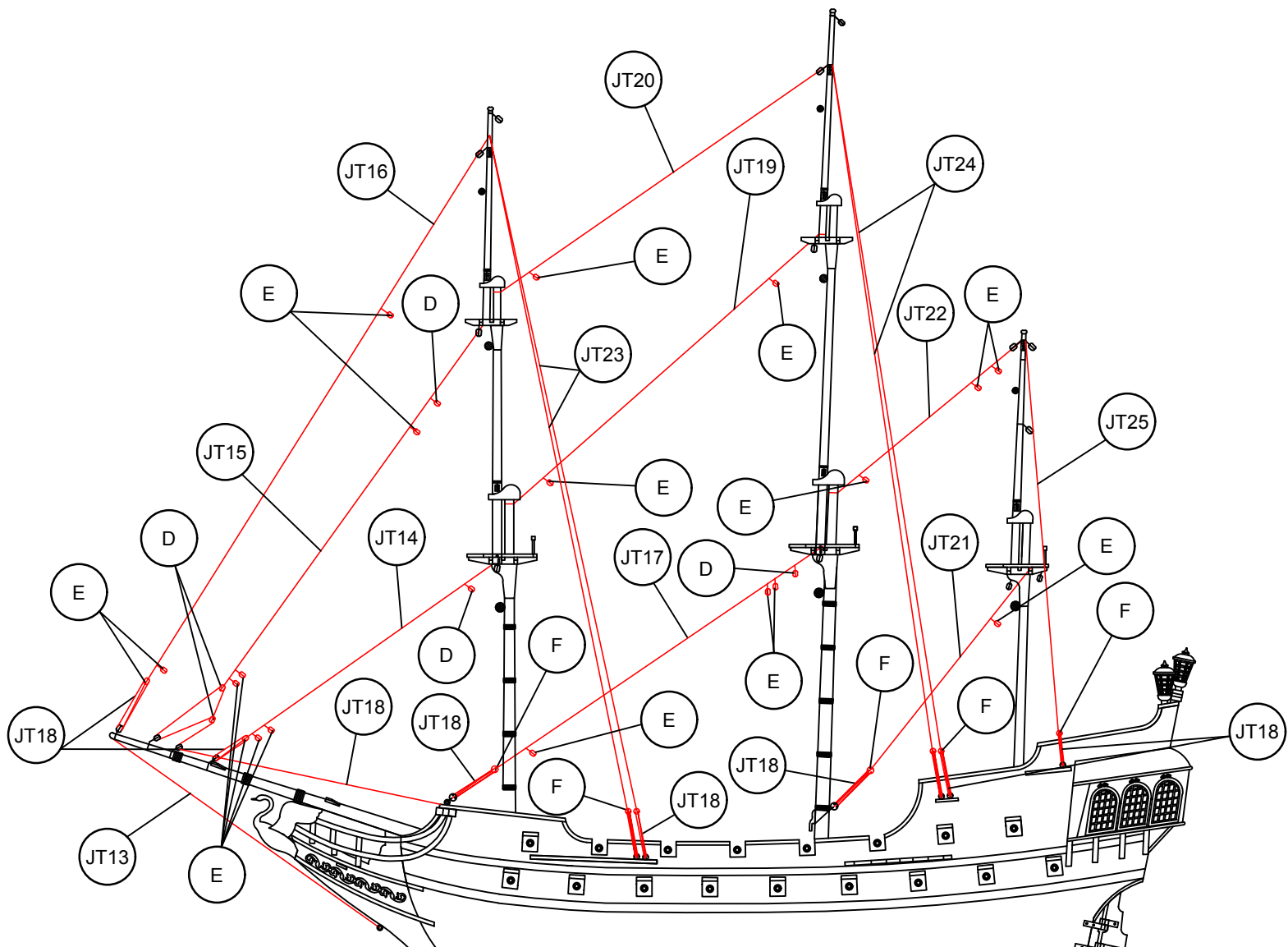

JT13	ø0,50x300	Hilo marrón / Brown thread / Fil brun /braunes Baumwollfaden / Filo marrone	JT21	ø0,50x300	Hilo marrón / Brown thread / Fil brun /braunes Baumwollfaden / Filo marrone
JT14	ø0,50x200	Hilo marrón / Brown thread / Fil brun /braunes Baumwollfaden / Filo marrone	JT22	ø0,50x300	Hilo marrón / Brown thread / Fil brun /braunes Baumwollfaden / Filo marrone
JT15	ø0,50x400	Hilo marrón / Brown thread / Fil brun /braunes Baumwollfaden / Filo marrone	JT23	ø0,50x1000	Hilo marrón / Brown thread / Fil brun /braunes Baumwollfaden / Filo marrone
JT16	ø0,50x550	Hilo marrón / Brown thread / Fil brun /braunes Baumwollfaden / Filo marrone	JT24	ø0,50x1100	Hilo marrón / Brown thread / Fil brun /braunes Baumwollfaden / Filo marrone
JT17	ø0,50x350	Hilo marrón / Brown thread / Fil brun /braunes Baumwollfaden / Filo marrone	JT25	ø0,50x500	Hilo marrón / Brown thread / Fil brun /braunes Baumwollfaden / Filo marrone
JT18	ø0,15x200	Hilo crudo / Raw thread / Fil brut / Rohes Baumwollfaden / Filo crudo	D	4	Madera / Wood / Bois / Holz / Legno
JT19	ø0,50x350	Hilo marrón / Brown thread / Fil brun /braunes Baumwollfaden / Filo marrone	E	4	Madera / Wood / Bois / Holz / Legno
JT20	ø0,50x350	Hilo marrón / Brown thread / Fil brun /braunes Baumwollfaden / Filo marrone	F	ø4	Madera / Wood / Bois / Holz / Legno

Cisne Negro

OCCRE

C

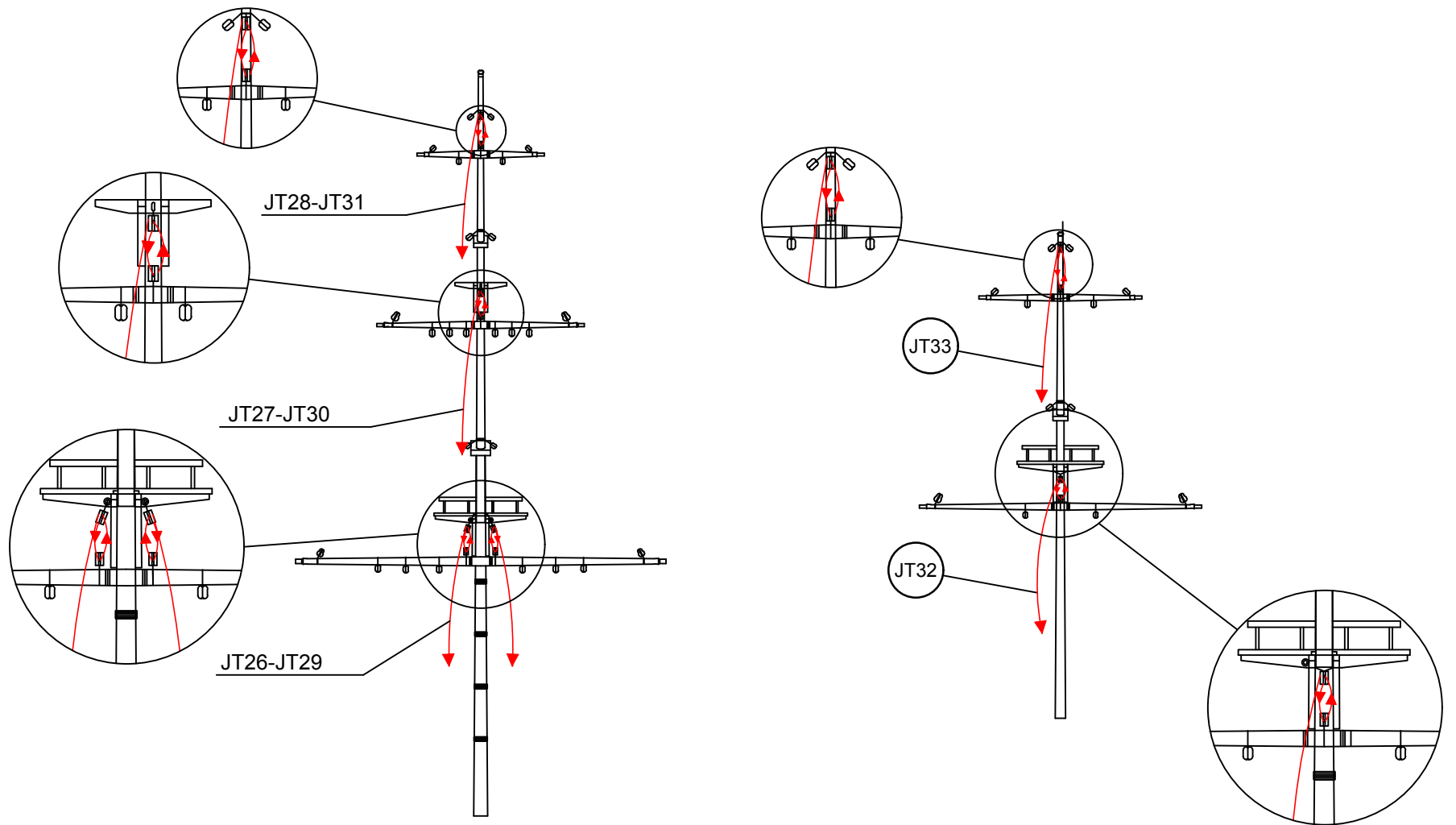

JT26	ø0,15x300	Hilo crudo / Raw thread / Fil brut / Rohes Baumwollfaden / Filo crudo	JT30	ø0,15x600	Hilo crudo / Raw thread / Fil brut / Rohes Baumwollfaden / Filo crudo
JT27	ø0,15x400	Hilo crudo / Raw thread / Fil brut / Rohes Baumwollfaden / Filo crudo	JT31	ø0,15x750	Hilo crudo / Raw thread / Fil brut / Rohes Baumwollfaden / Filo crudo
JT28	ø0,15x600	Hilo crudo / Raw thread / Fil brut / Rohes Baumwollfaden / Filo crudo	JT32	ø0,15x300	Hilo crudo / Raw thread / Fil brut / Rohes Baumwollfaden / Filo crudo
JT29	ø0,15x400	Hilo crudo / Raw thread / Fil brut / Rohes Baumwollfaden / Filo crudo	JT33	ø0,15x400	Hilo crudo / Raw thread / Fil brut / Rohes Baumwollfaden / Filo crudo

D

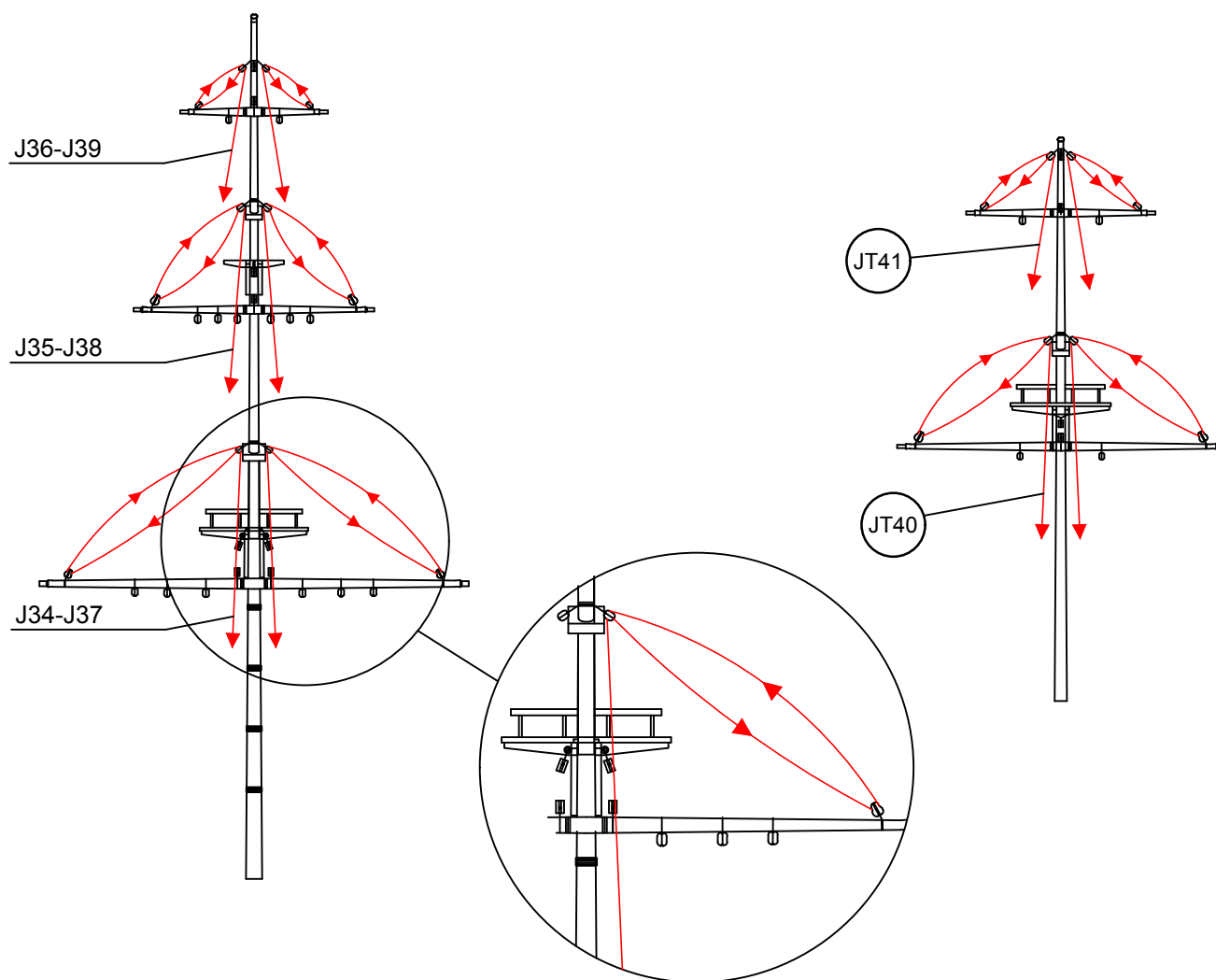

JT34	ø0,15x400	Hilo crudo / Raw thread / Fil brut / Rohes Baumwollfaden / Filo crudo	JT38	ø0,15x600	Hilo crudo / Raw thread / Fil brut / Rohes Baumwollfaden / Filo crudo
JT35	ø0,15x500	Hilo crudo / Raw thread / Fil brut / Rohes Baumwollfaden / Filo crudo	JT39	ø0,15x700	Hilo crudo / Raw thread / Fil brut / Rohes Baumwollfaden / Filo crudo
JT36	ø0,15x600	Hilo crudo / Raw thread / Fil brut / Rohes Baumwollfaden / Filo crudo	JT40	ø0,15x400	Hilo crudo / Raw thread / Fil brut / Rohes Baumwollfaden / Filo crudo
JT37	ø0,15x500	Hilo crudo / Raw thread / Fil brut / Rohes Baumwollfaden / Filo crudo	JT41	ø0,15x500	Hilo crudo / Raw thread / Fil brut / Rohes Baumwollfaden / Filo crudo

Cisne Negro

OCCRE

E

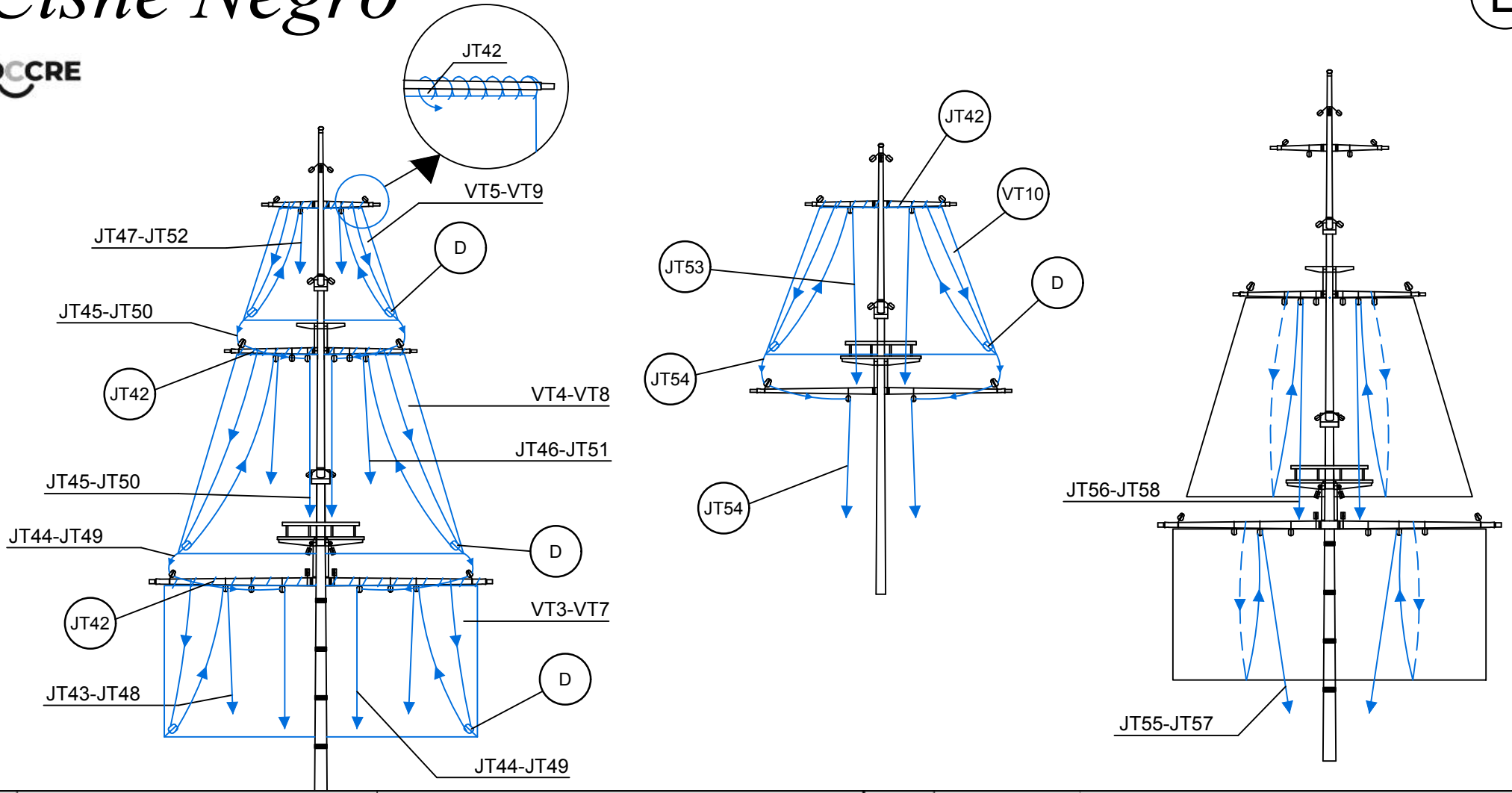

VT3-VT5	Preformado / Preformed/ Préformé / Vorgeformt / Preformato	Tela / Cloth / Étoffe / Stoff / Tela	JT50	∅0,15x700	Hilo crudo / Raw thread / Fil brut / Rohes Baumwollfaden / Filo crudo
VT7-VT10	Preformado / Preformed/ Préformé / Vorgeformt / Preformato	Tela / Cloth / Étoffe / Stoff / Tela	JT51	∅0,15x750	Hilo crudo / Raw thread / Fil brut / Rohes Baumwollfaden / Filo crudo
JT42	∅0,15x1000	Hilo crudo / Raw thread / Fil brut / Rohes Baumwollfaden / Filo crudo	JT52	∅0,15x700	Hilo crudo / Raw thread / Fil brut / Rohes Baumwollfaden / Filo crudo
JT43	∅0,15x550	Hilo crudo / Raw thread / Fil brut / Rohes Baumwollfaden / Filo crudo	JT53	∅0,15x500	Hilo crudo / Raw thread / Fil brut / Rohes Baumwollfaden / Filo crudo
JT44	∅0,15x400	Hilo crudo / Raw thread / Fil brut / Rohes Baumwollfaden / Filo crudo	JT54	∅0,15x450	Hilo crudo / Raw thread / Fil brut / Rohes Baumwollfaden / Filo crudo
JT45	∅0,15x650	Hilo crudo / Raw thread / Fil brut / Rohes Baumwollfaden / Filo crudo	JT55	∅0,15x500	Hilo crudo / Raw thread / Fil brut / Rohes Baumwollfaden / Filo crudo
JT46	∅0,15x500	Hilo crudo / Raw thread / Fil brut / Rohes Baumwollfaden / Filo crudo	JT56	∅0,15x650	Hilo crudo / Raw thread / Fil brut / Rohes Baumwollfaden / Filo crudo
JT47	∅0,15x700	Hilo crudo / Raw thread / Fil brut / Rohes Baumwollfaden / Filo crudo	JT57	∅0,15x700	Hilo crudo / Raw thread / Fil brut / Rohes Baumwollfaden / Filo crudo
JT48	∅0,15x600	Hilo crudo / Raw thread / Fil brut / Rohes Baumwollfaden / Filo crudo	JT58	∅0,15x800	Hilo crudo / Raw thread / Fil brut / Rohes Baumwollfaden / Filo crudo
JT49	∅0,15x600	Hilo crudo / Raw thread / Fil brut / Rohes Baumwollfaden / Filo crudo	D	4	Madera / Wood / Bois / Holz / Legno

F

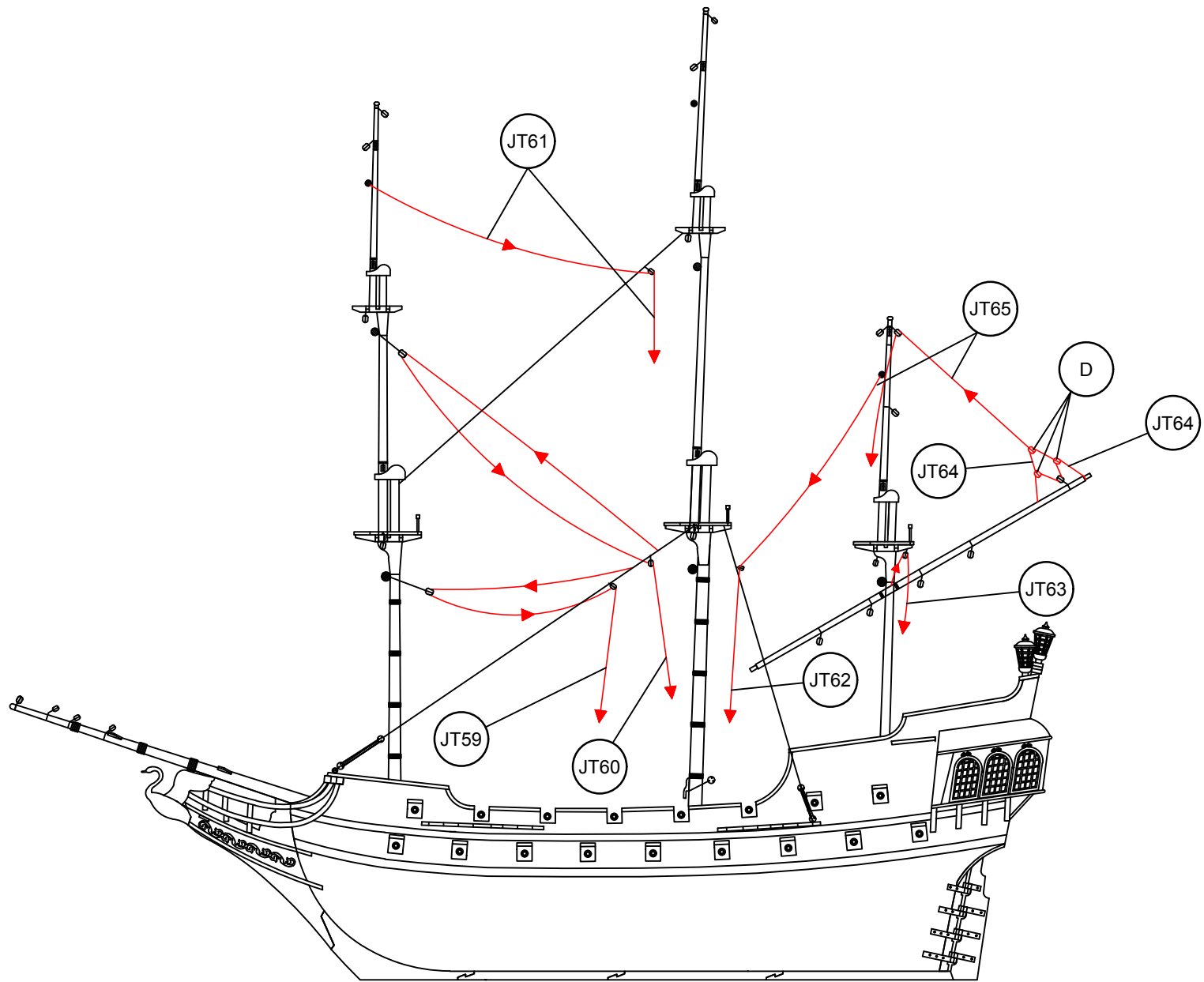

JT59	∅0,15x550	Hilo crudo / Raw thread / Fil brut / Rohes Baumwollfaden / Filo crudo	JT63	∅0,15x300	Hilo crudo / Raw thread / Fil brut / Rohes Baumwollfaden / Filo crudo
JT60	∅0,15x900	Hilo crudo / Raw thread / Fil brut / Rohes Baumwollfaden / Filo crudo	JT64	∅0,15x150	Hilo crudo / Raw thread / Fil brut / Rohes Baumwollfaden / Filo crudo
JT61	∅0,15x700	Hilo crudo / Raw thread / Fil brut / Rohes Baumwollfaden / Filo crudo	JT65	∅0,15x600	Hilo crudo / Raw thread / Fil brut / Rohes Baumwollfaden / Filo crudo
JT62	∅0,15x500	Hilo crudo / Raw thread / Fil brut / Rohes Baumwollfaden / Filo crudo			

Cisne Negro

OCCRE

G

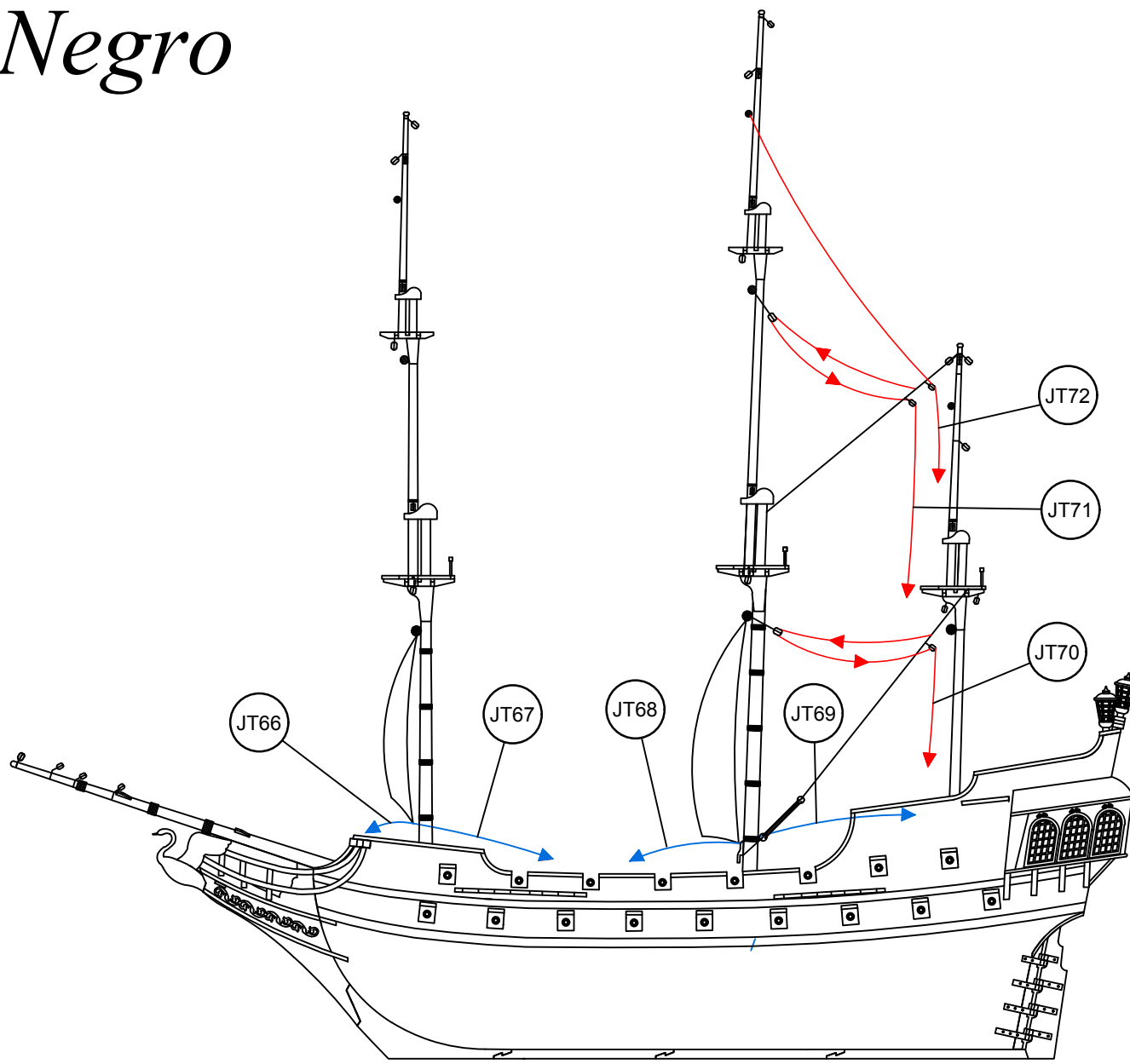

JT66	∅0,15x350	Hilo crudo / Raw thread / Fil brut / Rohes Baumwollfaden / Filo crudo	JT70	∅0,15x400	Hilo crudo / Raw thread / Fil brut / Rohes Baumwollfaden / Filo crudo
JT67	∅0,15x500	Hilo crudo / Raw thread / Fil brut / Rohes Baumwollfaden / Filo crudo	JT71	∅0,15x550	Hilo crudo / Raw thread / Fil brut / Rohes Baumwollfaden / Filo crudo
JT68	∅0,15x400	Hilo crudo / Raw thread / Fil brut / Rohes Baumwollfaden / Filo crudo	JT72	∅0,15x600	Hilo crudo / Raw thread / Fil brut / Rohes Baumwollfaden / Filo crudo
JT69	∅0,15x500	Hilo crudo / Raw thread / Fil brut / Rohes Baumwollfaden / Filo crudo			

H

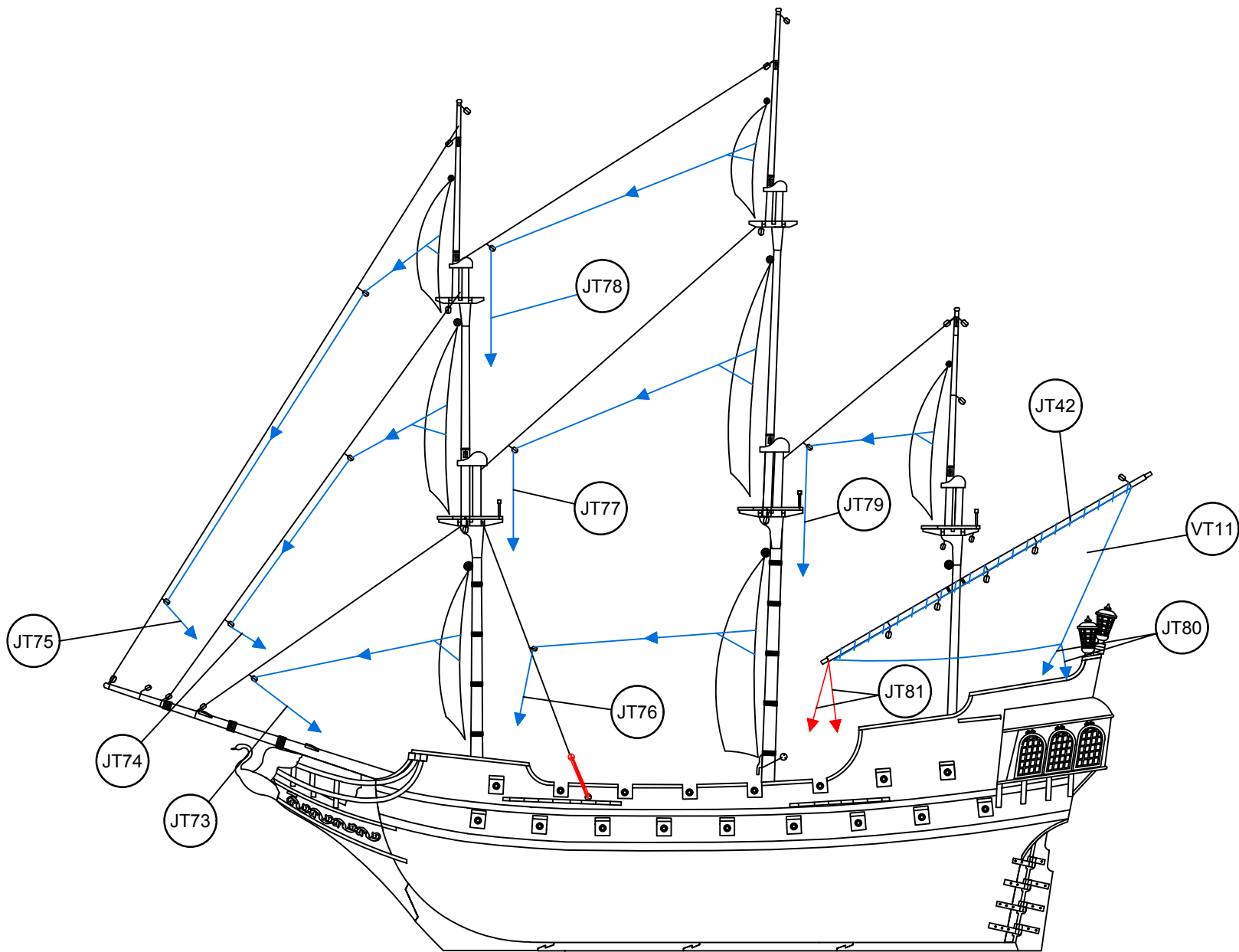

JT73	∅0,15x600	Hilo crudo / Raw thread / Fil brut / Rohes Baumwollfaden / Filo crudo	JT78	∅0,15x800	Hilo crudo / Raw thread / Fil brut / Rohes Baumwollfaden / Filo crudo
JT74	∅0,15x800	Hilo crudo / Raw thread / Fil brut / Rohes Baumwollfaden / Filo crudo	JT79	∅0,15x400	Hilo crudo / Raw thread / Fil brut / Rohes Baumwollfaden / Filo crudo
JT75	∅0,15x900	Hilo crudo / Raw thread / Fil brut / Rohes Baumwollfaden / Filo crudo	VT11	Preformado / Preformed / Préformé / Vorgeformt / Preformato	Tela / Cloth / Étoffe / Stoff / Tela
JT76	∅0,15x500	Hilo crudo / Raw thread / Fil brut / Rohes Baumwollfaden / Filo crudo	JT80	∅0,15x250	Hilo crudo / Raw thread / Fil brut / Rohes Baumwollfaden / Filo crudo
JT77	∅0,15x650	Hilo crudo / Raw thread / Fil brut / Rohes Baumwollfaden / Filo crudo	JT81	∅0,15x250	Hilo crudo / Raw thread / Fil brut / Rohes Baumwollfaden / Filo crudo

Cisne Negro

OCCRE

I

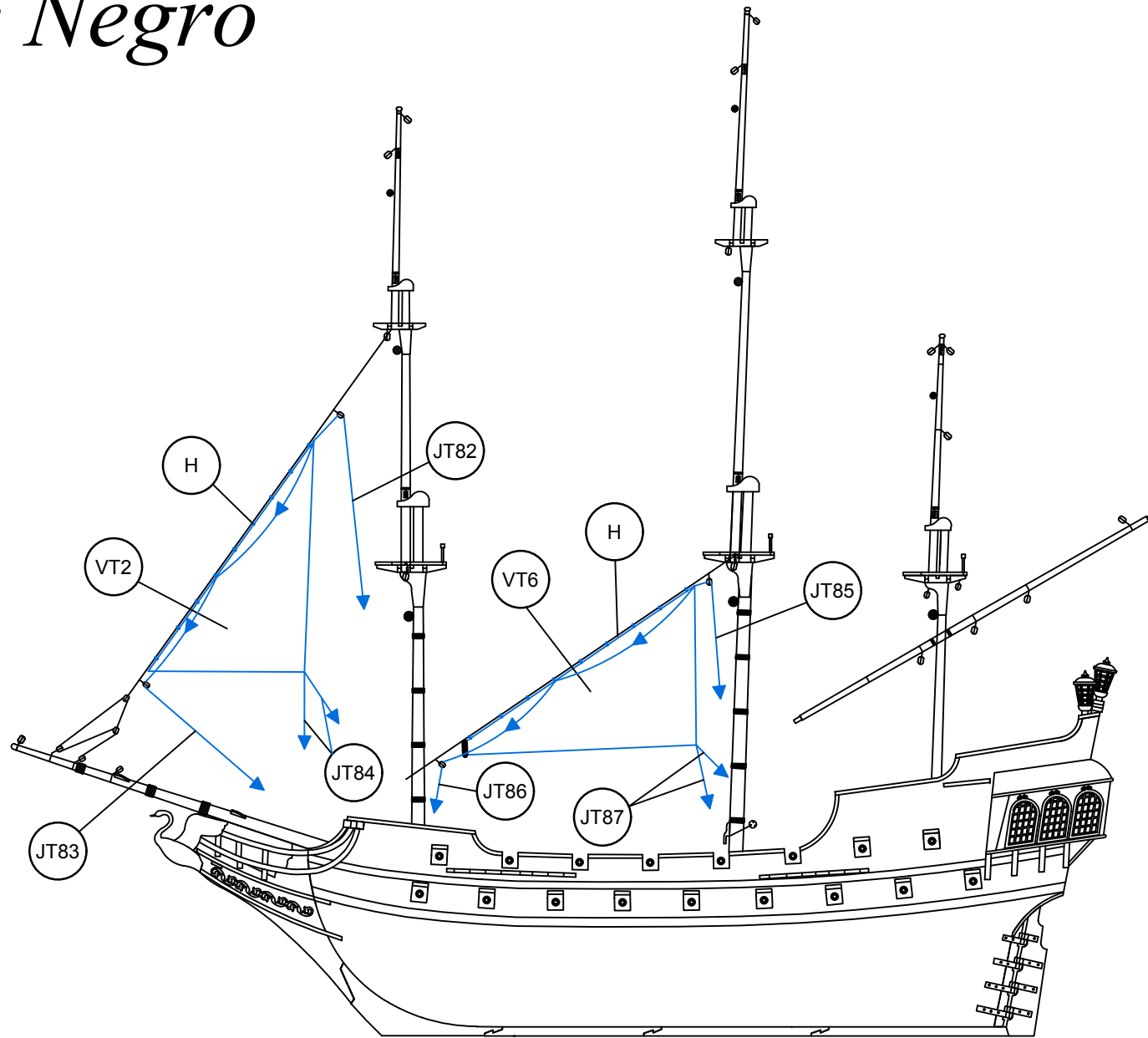

VT2	Preformado / Preformed/ Préformé / Vorgeformt / Preformato	Tela / Cloth / Étouffe / Stoff / Tela	JT85	ø0,15x400	Hilo crudo / Raw thread / Fil brut / Rohes Baumwollfaden / Filo crudo
JT82	ø0,15x500	Hilo crudo / Raw thread / Fil brut / Rohes Baumwollfaden / Filo crudo	JT86	ø0,15x400	Hilo crudo / Raw thread / Fil brut / Rohes Baumwollfaden / Filo crudo
JT83	ø0,15x450	Hilo crudo / Raw thread / Fil brut / Rohes Baumwollfaden / Filo crudo	JT87	ø0,15x500	Hilo crudo / Raw thread / Fil brut / Rohes Baumwollfaden / Filo crudo
JT84	ø0,15x400	Hilo crudo / Raw thread / Fil brut / Rohes Baumwollfaden / Filo crudo	H	ø3	Latón / Brass / Latón / Messing / Ottone
VT6	Preformado / Preformed/ Préformé / Vorgeformt / Preformato	Tela / Cloth / Étouffe / Stoff / Tela			

J

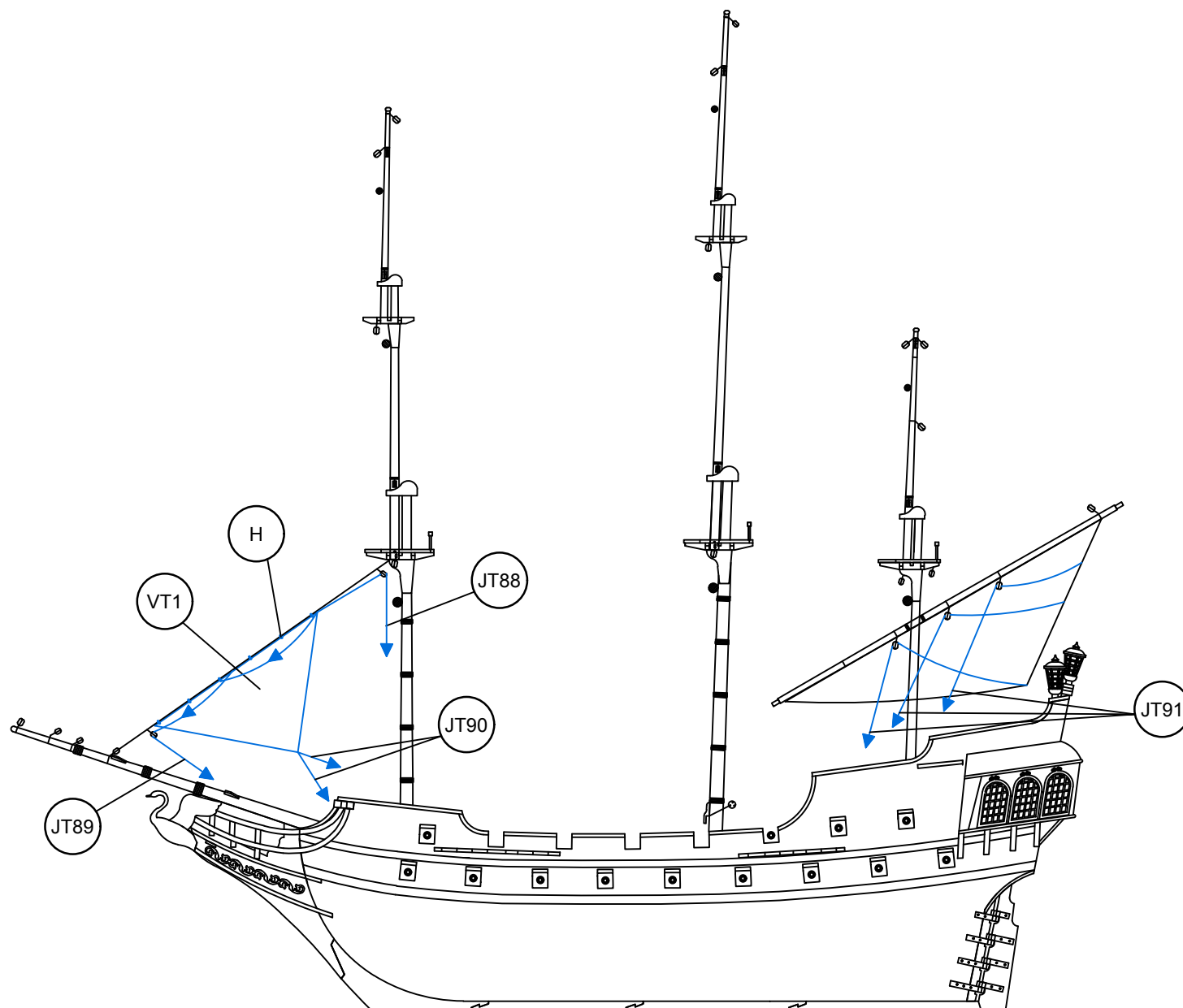

VT1	Preformado / Preformed/ Préformé / Vorgeformt / Preformato	Tela / Cloth / Étouffe / Stoff / Tela	JT90	ø0,15x550	Hilo crudo / Raw thread / Fil brut / Rohes Baumwollfaden / Filo crudo
JT88	ø0,15x500	Hilo crudo / Raw thread / Fil brut / Rohes Baumwollfaden / Filo crudo	JT91	ø0,15x800	Hilo crudo / Raw thread / Fil brut / Rohes Baumwollfaden / Filo crudo
JT89	ø0,15x450	Hilo crudo / Raw thread / Fil brut / Rohes Baumwollfaden / Filo crudo	H	ø3	Latón / Brass / Latón / Messing / Ottone

Cisne Negro

OCCRE

K

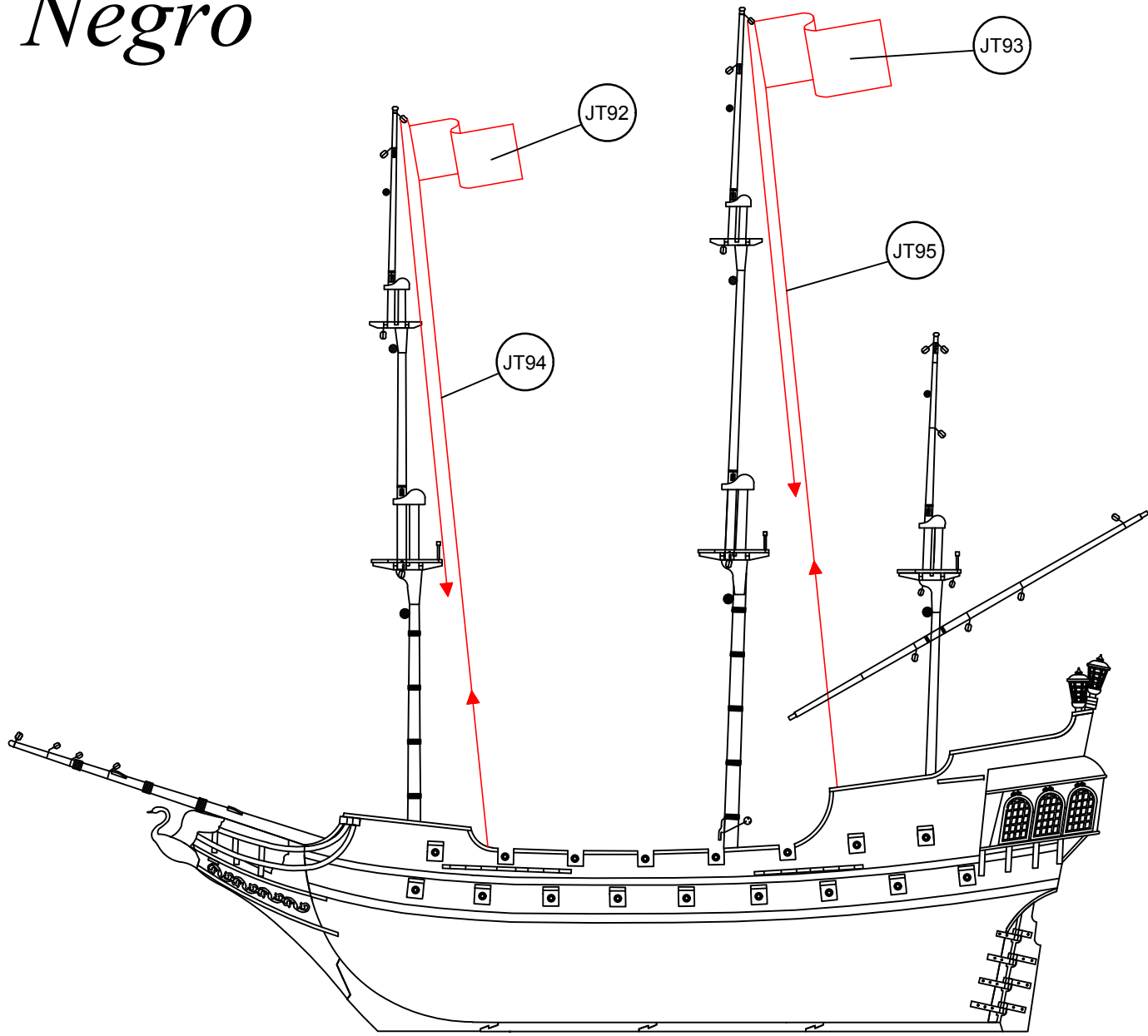

JT92	Preformado / Preformed/ Préformé / Vorgeformt / Preformato	Tela / Cloth / Étoffe / Stoff / Tela	JT94	∅0,15x800	Hilo crudo / Raw thread / Fil brut / Rohes Baumwollfaden / Filo crudo
JT93	Preformado / Preformed/ Préformé / Vorgeformt / Preformato	Tela / Cloth / Étoffe / Stoff / Tela	JT95	∅0,15x1000	Hilo crudo / Raw thread / Fil brut / Rohes Baumwollfaden / Filo crudo

L

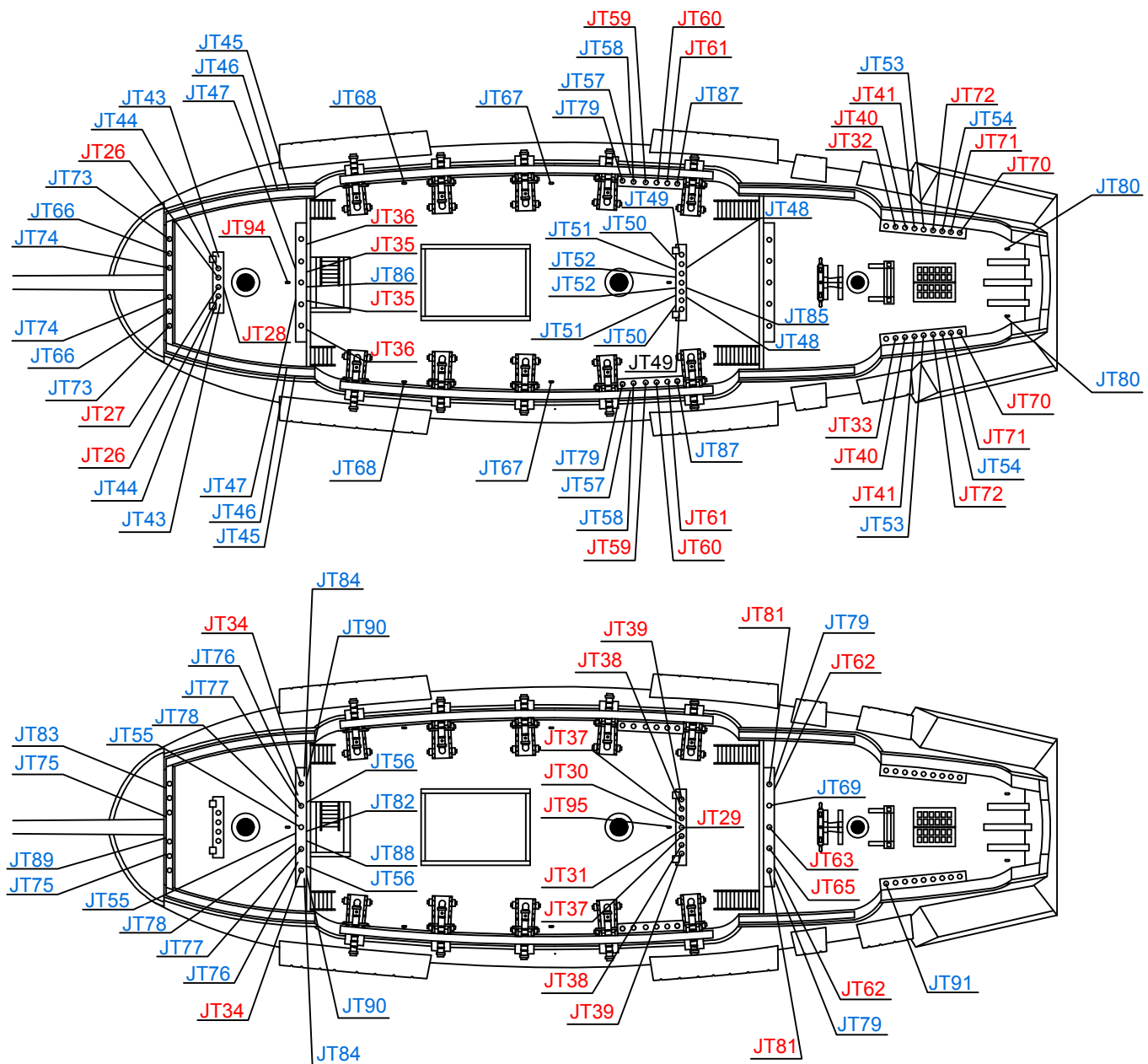

1 Instrucciones de montaje/Assembly instructions/ Instructions de montage/ Istruzioni di montaggio/Bastelanleitung.

Los textos te explican qué hacer en cada paso de la construcción de tu maqueta. Este bloque es tu guía para comprender cada paso antes de avanzar con el ensamblaje de las piezas.
 The instructions explain what to do at each step of constructing your model. This section serves as your guide to understanding each stage before you assemble the pieces.
 Les textes vous expliquent quoi faire à chaque étape de la construction de votre maquette. Ce bloc constitue votre guide pour comprendre chaque étape avant de progresser dans l'assemblage des pièces.
 I testi spiegano cosa fare in ogni fase della costruzione del modello. Questo blocco è la tua guida per comprendere ogni fase prima di passare all'assemblaggio dei pezzi.
 In der Anleitung werden die einzelnen Schritte zum Zusammenbau des Modellbausatzes beschrieben. Dieser Abschnitt erläutert die einzelnen Schritte und sollte vor Beginn des Zusammenbaus gelesen werden.



2 Listas de piezas/Parts lists/ Liste de pièces/ Elenchi dei pezzi/Liste der teile.

Las listas de piezas te muestran todas las piezas del kit. Te indican; el número, la cantidad, el tipo de material y las medidas de todas las piezas que necesitas. Es una referencia clave para identificar cada elemento antes y durante el montaje.
 The parts lists provide details of all the pieces in the kit. They indicate the part number, quantity, material type, and dimensions of everything you need. This is a crucial reference for identifying each component before and during assembly.
 Les listes des pièces vous montrent toutes les pièces du kit. Il vous indique : le nombre, la quantité, le type de matériel et les dimensions de toutes les pièces dont vous avez besoin. Il s'agit d'une référence essentielle pour identifier chaque élément avant et pendant le montage.
 Gli elenchi delle parti mostrano tutti i pezzi del kit. Indicano il numero, la quantità, il tipo di materiale e le misure di tutti i pezzi necessari. È un riferimento fondamentale per identificare ogni elemento prima e durante l'assemblaggio.
 Die Teilelisten enthalten alle Teile des Modellbausatzes. Angegeben werden Teilenummer, Anzahl, Material und Maße aller benötigten Teile. Anhang dieser Liste lassen sich die einzelnen Teile vor und während des Zusammenbaus einfach identifizieren.



3 Fotos paso a paso y hojas de identificación de piezas/Step by step photos and part identification sheets/ Photos pas-à-pas et feuilles d'identification des pièces/ Foto passo-passo e schede di identificazione dei pezzi/Bebilderte schritt-für-schritt-anleitung und liste mit teilekennzeichnung.

Este bloque incluye imágenes detalladas que ilustran cada paso del montaje, complementando las instrucciones escritas. Las fotos te guiarán visualmente para asegurar un ensamblaje correcto y preciso. Las hojas IP, te muestran la distribución de las piezas de las planchas cortadas por láser y las piezas de los fotograbados de latón.
 This section includes detailed images illustrating each assembly step, complementing the written instructions. The photographs visually guide you to ensure accurate and precise assembly. The IP sheets show the layout of the laser-cut sheet pieces and the brass photo-etched components.
 Ce bloc comprend des images détaillées qui illustrent chaque étape du montage, et complète les instructions écrites. Les photos vous guideront visuellement pour assurer un assemblage correct et précis. Les feuilles IP vous montrent la distribution des pièces des planches découpées au laser et les pièces des photogravures en laiton.
 Questo blocco comprende immagini dettagliate che illustrano ogni fase dell'assemblaggio, a complemento delle istruzioni scritte. Le immagini ti guideranno visivamente per garantire un montaggio corretto e accurato. I fogli IP mostrano la disposizione delle parti in lamiera tagliata al laser e delle parti fotoincise in ottone.
 Dieser Abschnitt ergänzt die schriftliche Bastelanleitung und enthält Bilder, die alle Schritte des Zusammenbaus veranschaulichen. Die Fotos helfen dabei, das Modell zusammenzubauen. Die IP-Blätter zeigen, wo die lasergeschnittenen Blechteile und der Fotoätzteile aus Messing angebracht werden müssen.



4 Planos de mástiles, velas y pantillas/Mast and sail plans and templates/Plans des mâts, voiles et bases/ Piani degli alberi, vele e sagome/ Pläne für bemastung und segel und schablonen.

Los planos de mástiles están impresos a escala 1/1 y te servirán de guía para elaborar todos los palos de tu maqueta. Los planos de velas están impresos a escala 1/1. Coloca cada vela sobre su dibujo para poder identificarla correctamente. Las plantillas también están impresas a escala 1/1, y te servirán para elaborar piezas varias y posicionarlas sobre el barco.
 The rigging plans are printed at a 1:1 scale and will guide you in crafting all the spars for your model. The sail plans are also printed at a 1:1 scale. Place each sail over its corresponding drawing to identify it correctly. Templates, also printed at a 1:1 scale, will assist you in crafting various pieces and positioning them on the ship.
 Les plans des mâts sont imprimés à l'échelle 1/1 et vous serviront à élaborer tous les bâtons de votre maquette. Les plans des voiles sont imprimés à l'échelle 1/1. Placez chaque voile sur son dessin pour pouvoir l'identifier correctement. Les bases sont également imprimées à l'échelle 1/1 et vous serviront à élaborer différentes pièces et à les positionner sur le bateau.
 I piani degli alberi sono stampati in scala 1/1 e serviranno da guida per realizzare tutti gli alberi del modello. I piani delle vele sono stampati in scala 1/1. Posizionare ogni vela sul suo disegno per poterla identificare correttamente. Anche le sagome sono stampate in scala 1/1 e ti aiuteranno a realizzare le varie parti e a posizzionarle sulla barca.
 Die Mastpläne im Maßstab 1:1 dienen als Anleitung zum Bau aller Masten des Modells. Die Segelpläne sind ebenfalls im Maßstab 1:1. Um die einzelnen Segel korrekt zuzuordnen, jedes Segel auf die Vorlage legen. Die Schablonen im Maßstab 1:1 dienen dazu, Einzelteile anzufertigen und anschließend auf dem Modell anzubringen.

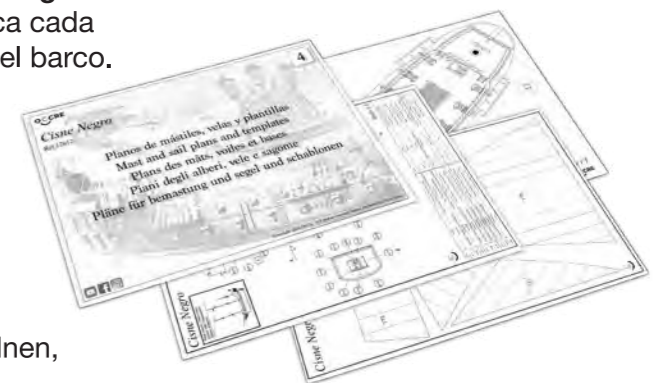

5 Planos de jarcia/Rigging plans/Plans des gréements/Piani delle sartie/Pläne der takelung.

Estos planos te muestran como colocar los hilos de los mástiles. Sigue el orden alfanumérico de los planos de jarcia para colocar todos los hilos de la arboladura. Estos mismos planos te servirán de guía para colocar las velas y las banderas.
 These plans show how to arrange the standing rigging on the masts. Follow the alphanumeric sequence on the rigging plans to correctly position all the standing and running rigging. These same plans will also guide you in positioning the sails and flags.
 Ces plans vous montrent comment placer les fils des mâts. Suivez l'ordre alphabétique des plans des gréements pour placer tous les fils de mâture. Ces mêmes plans vous serviront de guide pour placer les voiles et les drapeaux.
 Questi piani mostrano come posizionare le cime degli alberi. Segui l'ordine alfanumerico dei piani di sartie per posizionare tutte le cime del sartie. Questi stessi piani serviranno da guida per la collocazione delle vele e delle bandiere.
 Diese Pläne zeigen, wie das Tauwerk an den Masten angebracht wird. Zum Anbringen des Tauwerks die alphanumerische Reihenfolge der Takelage-Pläne beachten. Diese Pläne dienen auch als Anleitung zum Platzieren von Segeln und Flaggen.



Imprimación/Primer/Apprêt/Priming/Grundierung.



Producto con base de agua. Se recomienda aplicar siempre imprimación a todas aquellas piezas de metal, madera o plástico, que deban pintarse de color. Es importante aplicar una capa uniforme y dejar secar al menos 30 minutos antes del repintado.

Water-based product. It is always advisable to apply primer to all metal, wood, or plastic pieces that need to be painted. Apply an even coat and allow it to dry for at least 30 minutes before repainting.

Produit à base d'eau. Il est conseillé de toujours appliquer l'apprêt sur les pièces en métal, bois ou plastique, qui doivent être peintes. Il est important d'appliquer une couche uniforme et de laisser sécher au moins 30 minutes avant de peindre.

Prodotto a base d'acqua. Si raccomanda di applicare sempre un primer su tutte le parti in metallo, legno o plastica da verniciare a colori. È importante applicare uno strato uniforme e lasciare asciugare per almeno 30 minuti prima di riverniciare.

Produkt auf Wasserbasis. Es wird empfohlen, alle Metall, Holz- und Kunststoffteile, die farbige lackiert werden sollen, mit einer Grundierung zu versehen.

Die Grundierung als gleichmäßige Schicht auftragen und mindestens 30 Minuten lang trocknen lassen, bevor die Farbe aufgetragen wird.

Cola blanca o de carpintero/White, or carpenter's, glue/Colle blanche ou de menuisier/Colle bianca o da falegname/Weißer Kleber (Tischlerleim).



Producto con base de agua. Para unión de piezas de madera. Su mayor uso es en la construcción del esqueleto del casco y en la colocación del primer forro de éste.

For joining pieces of wood together. Mainly used for gluing together the skeleton of the hull and attaching the first layer of lining to it. In all cases, always follow the manufacturer's recommendations.

Pour l'assemblage de pièces en bois. On l'utilisera majoritairement pour la construction de la charpente de la coque et pour l'installation du premier bordé de celle-ci.

Per unire i pezzi di legno. Si usa maggiormente nella costruzione dello scheletro dello scafo e per collocare il primo rivestimento dello scafo.

Der Schusterleim wird zur Beplankung des Decks und für Teile verwendet, die mit dünnen Holzplättchen abgedeckt werden. Dieser Leim wird hauptsächlich zur Beplankung des Decks und zur zweiten Rumpfbeplankung verwendet.

Tintes/Stains/Teinte/Tintura/Tönung.



Producto con base de agua. Se utiliza para dar un color a las piezas de madera que no lo tienen de origen. Es recomendable, aplicar el producto con un pincel. Se puede aumentar la intensidad de color aplicando varias capas.

Water-based product. Used to add colour to wooden pieces that are originally uncoloured. It is best to apply the product using a brush. The depth of the colour can be increased by applying several coats.

Produit à base d'eau. Utilisée pour donner de la couleur aux pièces de bois qui n'en ont pas à l'origine. Il est conseillé d'appliquer le produit à l'aide d'un pinceau. L'intensité de la couleur peut être renforcée en appliquant plusieurs couches.

Prodotto a base d'acqua. Si usa per dare un colore ai pezzi di legno che ne sono privi in origine. Si consiglia di applicare il prodotto con un pennello. L'intensità del colore può essere aumentata applicando più mani.

Produkt auf Wasserbasis. Wird verwendet, um Teilen oder Oberflächen eine gealterte Optik zu verleihen. Der Lack kann mit einem Pinsel oder einem trockenen Tuch aufgetragen werden. Die Intensität des Anstrichs kann bei Bedarf durch Verdünnen mit Wasser reguliert werden.

Pinturas/Paints/Peintures/Farben/Pitture.



Producto con base de agua. Se recomienda aplicar para pintar piezas de metal, madera, plástico, etc. Es recomendable extender bien el producto para conseguir un color uniforme, dejándolo secar entre capa y capa.

Water-based product. Recommended for painting metal, wood, plastic pieces, etc. It is advisable to apply the product evenly to achieve a uniform colour, allowing it to dry between coats.

Produit à base d'eau. Application conseillée pour peindre des pièces en métal, bois, plastique, etc. Bien étaler le produit pour obtenir une couleur uniforme, puis laisser sécher entre deux couches.

Prodotto a base d'acqua. Sono consigliate per la verniciatura di parti metalliche, legno, plastica, ecc. Si consiglia di stendere bene il prodotto per ottenere un colore uniforme, lasciandolo asciugare tra una mano e l'altra.

Produkt auf Wasserbasis. Empfohlen zum Anmalen von Metallteilen, Holz, Kunststoff usw. Die Farbe gut verteilen, um eine gleichmäßige Oberfläche zu erhalten, die einzelnen Schichten gut trocknen lassen.

Pegamento de secado rápido (cianoacrilato)/Quick-drying glue. Colle à séchage rapide/Collante ad asciugatura rapida/Sekundenkleber.



Para piezas que sean difíciles de mantener en su posición final y que necesiten un secado casi instantáneo. Recomendado para la colocación de piezas pequeñas sobre las cubiertas y distintas partes del casco y mástiles.

For parts that are difficult to hold in their final position and which need to set instantly. Recommended for fitting small parts onto the decks, different parts of the hull or the masts.

Pour pièces difficiles à maintenir dans leur position finale et requérant un séchage presque instantané. Recommandé pour l'installation de petites pièces sur les ponts et autres parties de la coque et des mâts.

Per pezzi difficili da mantenere nella loro posizione finale e che richiedano una presa quasi rapida. Raccomandato per collocare i pezzi piccoli sulle coperte e su diverse parti della scafo ed alberi.

Für Teile, die schlecht in Position zu halten sind und schnell fixiert werden müssen. Empfohlen zum Aufkleben kleiner Bauteile auf das Deck und an Teile von Rumpf und Masten.

Barnices/Varnishes/Vernis/Vernici/Lacke.



Producto con base de agua. Se utiliza para dar un acabado adecuado a las piezas de madera, (teñidas o no), a cascos ya forrados, mástiles, etc. Es recomendable, aplicar el producto extendiéndolo ampliamente con un pincel.

Water-based product. Used to provide a suitable finish to wooden pieces (whether stained or not), to completed hulls, masts, etc. It is best to apply the product evenly with a brush.

Produit à base d'eau. Est utilisé pour procurer une finition adéquate aux pièces en bois (teintes ou pas) ou à des coques déjà bordées, des mâts, etc. Il est conseillé d'appliquer le produit en l'étalant largement à l'aide d'un pinceau.

Prodotto a base d'acqua. Si usa per dare una finitura adeguata a parti in legno (tinte o non tinte), scafi già rivestiti, alberi, ecc. Si consiglia di applicare il prodotto stendendolo ampiamente con un pennello.

Produkt auf Wasserbasis. Der Lack wird verwendet, um Holzteilen (gebeizt oder ungebeizt), verkleideten Rümpfen, Masten usw. eine geeignete Oberfläche zu verleihen. Das Produkt am besten breitflächig mit einem Pinsel auftragen.

Betún de Judea/Bitumen of Judea/Cirage/Bitume di giudea/Asphaltfarbe.



Producto con base de agua. Se utiliza para dar un aspecto de viejo a piezas o superficies. Se puede aplicar a pincel o con un paño seco. Se puede ajustar su intensidad o eliminarlo, diluyéndolo con agua.

Water-based product. Used to give an aged appearance to pieces or surfaces. It can be applied with a brush or a dry cloth. Its intensity can be adjusted or removed by diluting it with water.

Produit à base d'eau. Est utilisé pour donner un aspect vieilli à des pièces ou des surfaces. Peut être appliqué au pinceau ou à l'aide d'un chiffon sec. Son intensité peut être réajustée ou éliminée, en diluant avec de l'eau.

Prodotto a base d'acqua. Si usa per dare un aspetto invecchiato a parti o superfici. Può essere applicato a pennello o con un panno asciutto. Può essere regolato in intensità o rimosso diluendolo con acqua.

Produkt auf Wasserbasis. Wird verwendet, um Teilen oder Oberflächen eine gealterte Optik zu verleihen. Der Lack kann mit einem Pinsel oder einem trockenen Tuch aufgetragen werden. Die Intensität des Anstrichs kann bei Bedarf durch Verdünnen mit Wasser reguliert werden.

Cola de contacto o de zapatero/Contact or cobbler's glue/Colle de contact ou de cordonnier/Colle da contatto o da calzolaio/Kontaktkleber (Schusterleim).



Para la sujeción de los forros de cubiertas y piezas que se deban cubrir con chapas finas de madera. Generalmente se aplica en el forrado de cubiertas y el segundo forro del casco.

For gluing into place the decks and the parts that are covered with fine wood veneer. Generally it is used to attach the planking to the decks and the second layer of lining of the hull.

Pour la fixation des bordés des ponts et des pièces qui seront recouvertes de fines lamelles de bois. Appliquée généralement sur le bordage des ponts et le deuxième bordé de la coque.

Per incollare i rivestimenti delle coperte e per i pezzi che devono poi essere ricoperti con fine lamina di legno. Generalmente si applica al rivestimento delle coperte e il secondo rivestimento dello scafo.

Der Schusterleim wird zur Beplankung des Decks und für Teile verwendet, die mit dünnen Holzplättchen abgedeckt werden. Dieser Leim wird hauptsächlich zur Beplankung des Decks und zur zweiten Rumpfbeplankung verwendet.

Masilla tapagrietas/Crack filler/Mastic anti-fissures/Fugenkitt/Stucco per fessure.



Producto con base de agua. Se utiliza para rellenar grietas y nivelar las superficies. Para disimular las uniones entre piezas de estructuras, etc. Es aconsejable aplicar el producto con espátula y dejar secar una hora antes de lijar.

Water-based product. Used to fill cracks and level surfaces, as well as to conceal joints between structural pieces, etc. Apply the product with a spatula and allow it to dry for an hour before sanding.

Produit à base d'eau. Est utilisé pour remplir les fissures et niveler les surfaces. Pour dissimuler les unions entre les pièces des structures, etc. Il est conseillé d'appliquer le produit à l'aide d'une spatule et de laisser sécher une heure avant de poncer.

Prodotto a base d'acqua. Utilizzato per coprire crepe e livellare superfici. Per mascherare le giunzioni tra parti di strutture, ecc. Si consiglia di applicare il prodotto con una spatola e di lasciarlo asciugare per un'ora prima di carteggiarlo. Produkt auf Wasserbasis. Der Kitt wird zum Füllen von Rissen und zum Herstellen einer gleichmäßigen Oberfläche verwendet. Und zum Verdecken von Verbindungsstellen zwischen Teilen usw. Das Produkt am besten mit einem Spachtel auftragen und vor dem Glattschmirgeln eine Stunde lang trocknen lassen.



VIDEO

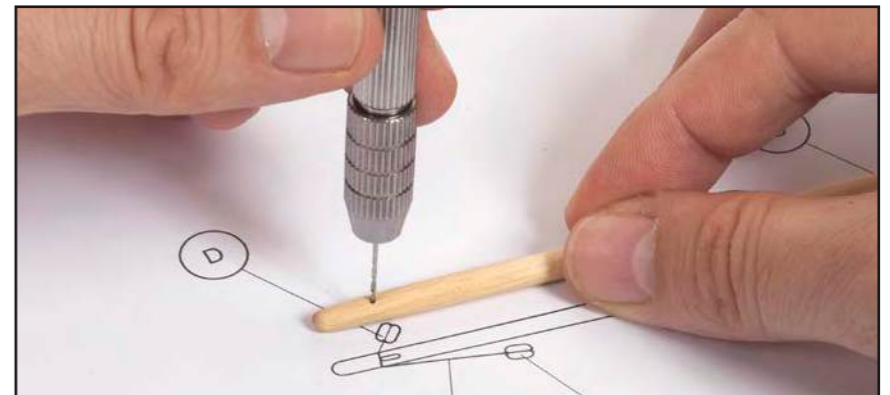
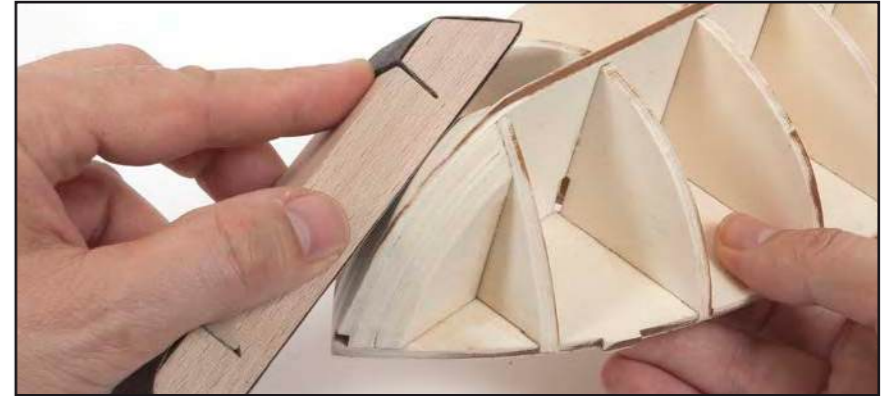
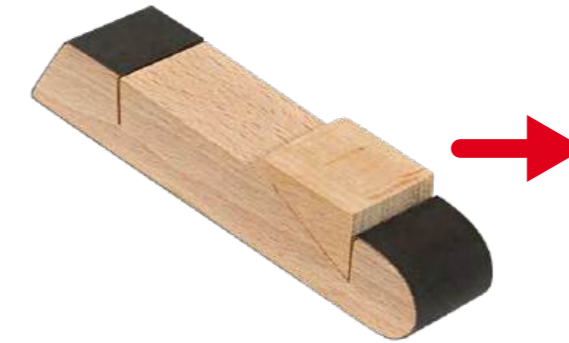
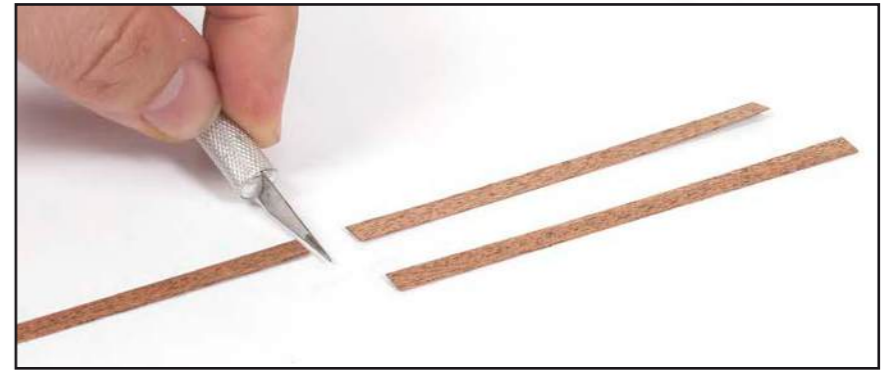
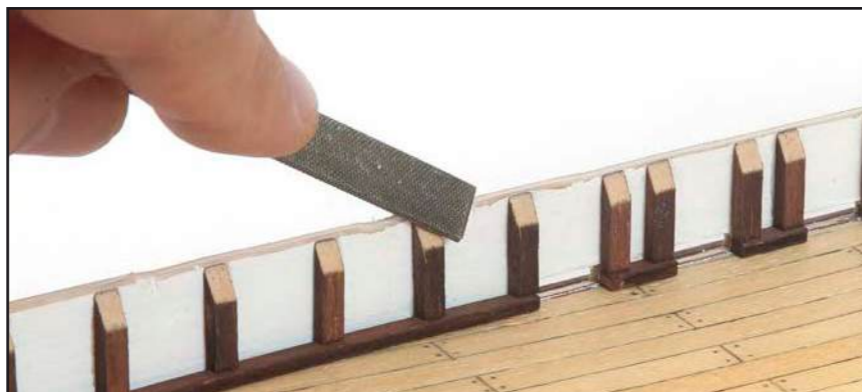
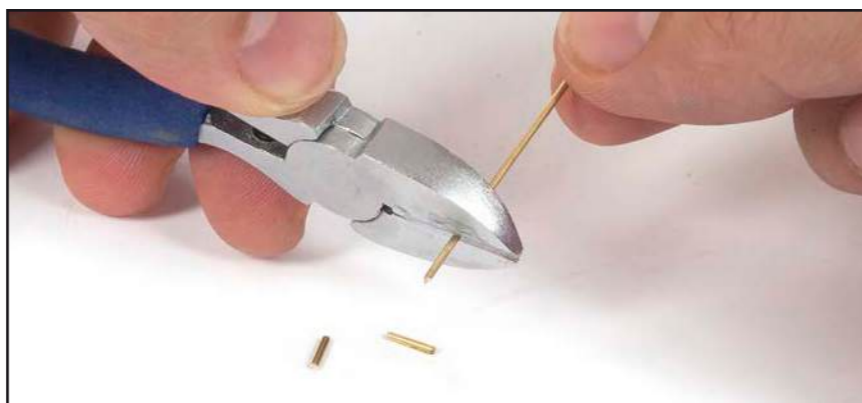
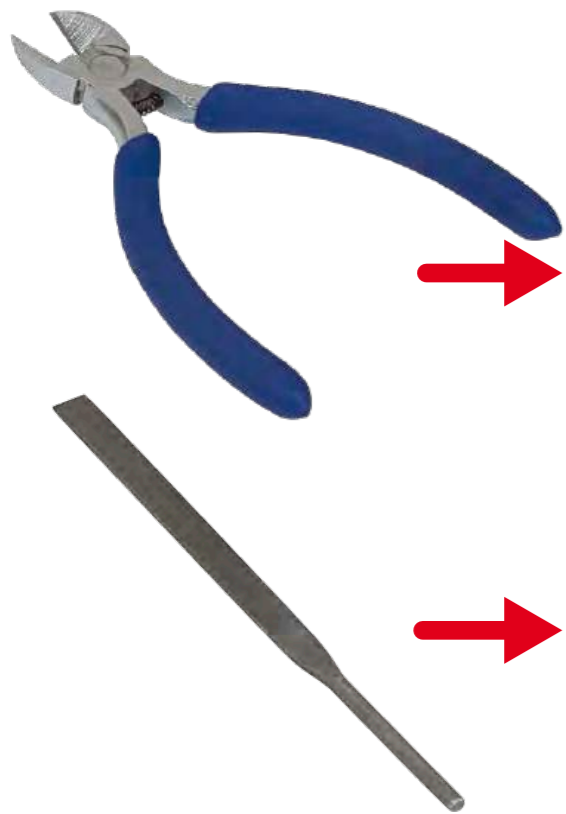
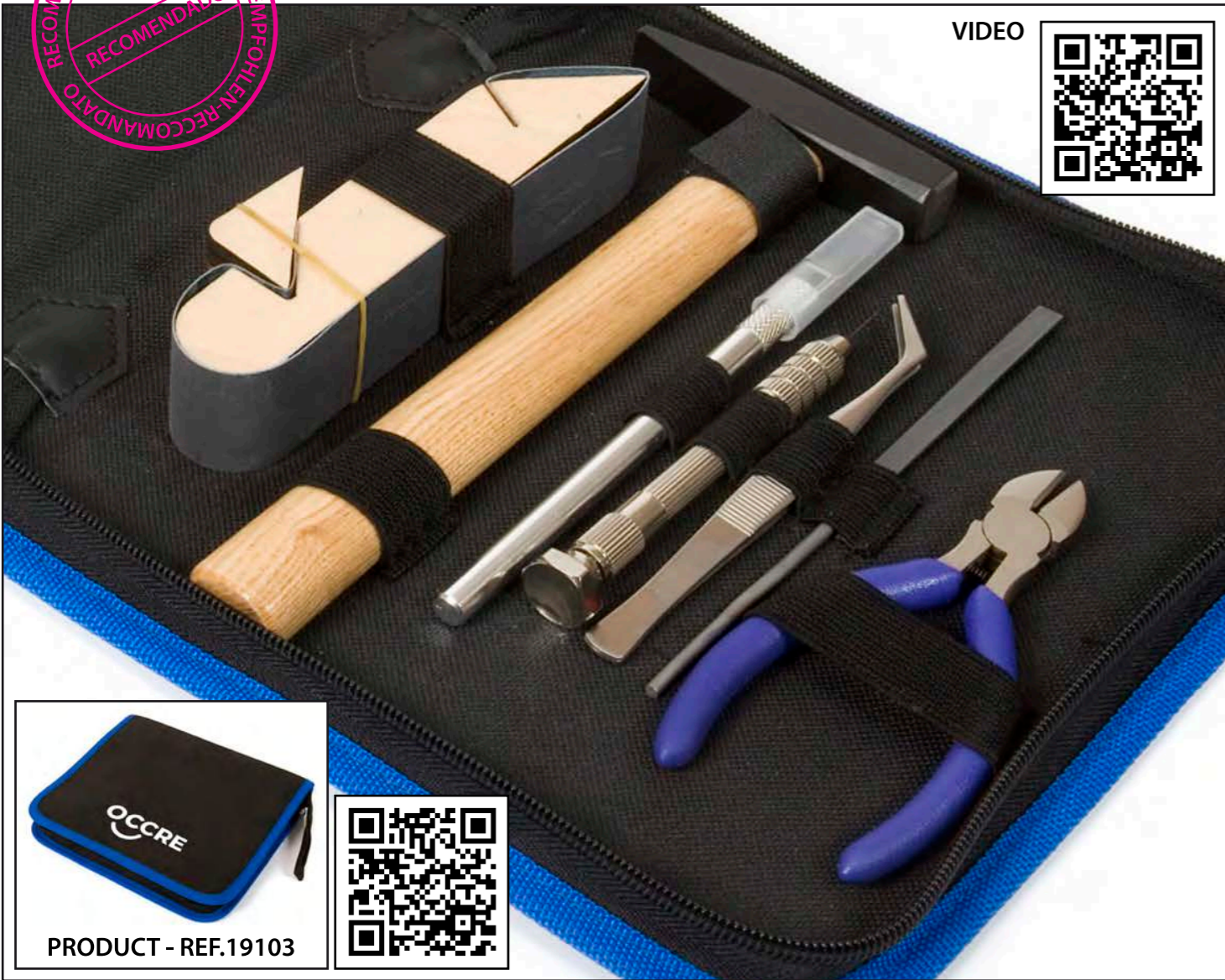

Herramientas / Tools / Outils / Grundlegende / Strumenti / Werkzeuge

