

VANTAGE 2.0

BRUSHLESS

1/10TH SCALE 4WD ELECTRIC POWERED
READY-TO-RUN OFF ROAD RACING BUGGY



ENGLISH INSTRUCTIONS – PAGE 2
FRANÇAIS INSTRUCTIONS – PAGE 11

INSTRUCTION BOOK AND COMPONENT LISTING



www.ftx-rc.com





FTX Vantage 2.0 Brushless 1/10th Scale 4WD Electric Powered Ready-To-Run Off Road Buggy

Congratulations on your purchase of the FTX 'Vantage 2.0 Brushless' electric off road Buggy.



This 1/10th scale model has been factory assembled and all electrics installed and set up to make it the easiest possible introduction to the sport of driving RC cars.

WARNING: Read the ENTIRE instruction manual to become familiar with the features of the product before operating.

Failure to operate the product correctly can result in damage to the product, personal property and cause serious injury. This is NOT a toy and must be operated with caution and common sense.

Failure to operate this product in a safe and responsible manner could result in damage, injury or damage to other property.

This product is not intended for use by children without direct adult supervision.

It is essential to read and follow all the instructions and warnings in the manual, prior to assembly, set-up or use, in order to operate correctly and avoid damage or serious injury.

Safety Precautions and Warnings

- You are responsible for operating this model such that it does not endanger yourself and others, or result in damage to the product or the property of others.
- This model is controlled by a radio which is possibly subject to interference which can cause momentary loss of control so it is advisable to always keep a safe distance to avoid collisions or injury.
- Age Recommendation: 14 years or over. This is not a toy. This product is not intended for use by children without direct adult supervision.

Carefully follow these directions and warnings, plus those of any additional equipment associated with the use of this model, chargers, ESC and motors, radio etc.

- Never operate your model with low transmitter batteries.
- Always operate your model in an open area away from cars, traffic or people.
- Never operate the model in the street or in populated areas.
- Always keep the vehicle in direct line of sight, you cannot control what you cannot see!
- Keep all chemicals, small parts and anything electrical out of the reach of children.
- Although splash-proof the car and electronics are not designed to be subjected to extended moisture exposure or submersion. To do so will result in permanent damage.
- Avoid injury from high speed rotating parts, gears and axles etc.
- Novices should seek advice from more experienced people to operate the model correctly and meet its performance potential.
- Exercise caution when using tools and sharp instruments.
- Do not put fingers or any objects inside rotating and moving parts.
- Take care when carrying out repairs or maintenance as some parts may be sharp.
- Do NOT touch equipment such as the motor, electronic speed control and battery, immediately after using your model because they can generate high temperatures.
- Always turn on your transmitter before you turn on the receiver in the car. Always turn off the receiver before turning your transmitter off.
- Keep the wheels of the model off the ground and keep your hands away from the wheels when checking the operation of the radio equipment.
- Prolong motor life by preventing overheat conditions. Undue motor wear can result from frequent turns, rapid change of direction forwards/backwards, continuous stop/starts, pushing/pulling objects, driving in deep sand and tall grass, or driving continuously up hill.

Contents:

FTX Vantage 2.0 Brushless Buggy
Transmitter: 2.4ghz Steerwheel
Charger: 2S/3S 800mA Balance
Battery: 3250mAh 7.4V 2S LiPo
Voltz LiPo Safety Charge Sack





REQUIRED EQUIPMENT FOR OPERATION

1. Tools required for building and maintenance:

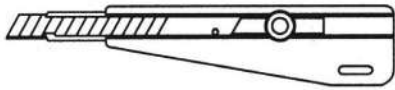

● Hobby knife



● Precision ruler

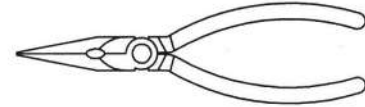

● Needle nose pliers

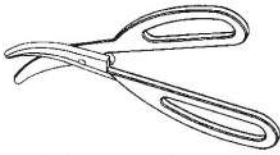

● Lexan scissors

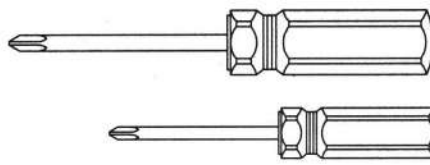

● Flat and Philips screwdriver

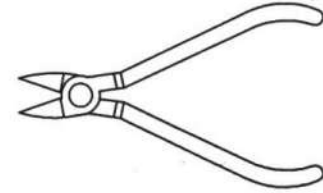

● Wire cutters

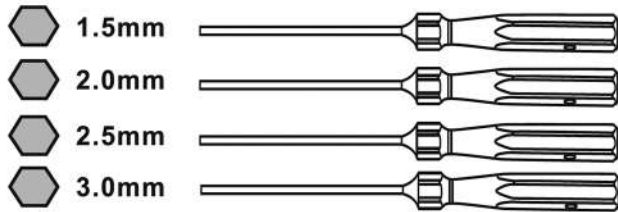

Hex. Screwdrivers

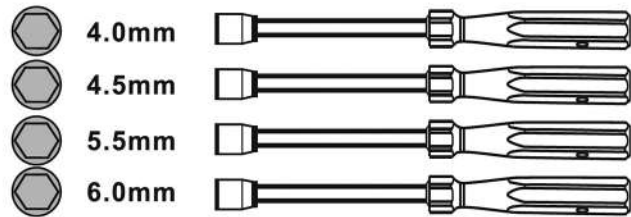

Socket Head Drivers

WARNING!

Do not use a power screw driver to install screws into nylon or plastic materials. The fast locking may heat up the screws being installed that may break the molded parts or strip the threads during installation.

2. Additional items needed for operation:

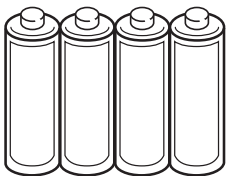

4 pcs AAA Alkaline Batteries

IMPORTANT!

Check that all screws and nuts are tight before each use.



CHARGING/INSTALLING THE BATTERY

IMPORTANT! ALWAYS CHARGE IN A LIPO SACK OR TIN AWAY FROM FLAMMABLE MATERIALS (SUCH AS CARPET). ALWAYS MONITOR CHARGE STATUS INCASE YOU NEED TO STOP WITH IMMEDIATE EFFECT AND ALWAYS STORE YOUR MODEL WITH THE BATTERY UNPLUGGED AND REMOVED.

The included 900mAh mains LiPo balance charger will take up to 2.5 hours to re-charge the LiPo battery depending on how discharged it is. Before you start charging ensure that your LiPo battery is put inside the Voltz Vault safety LiPo sack.

(Lipo batteries can be dangerous and must be handled with care. Before commencing with charging ensure you familiarise yourself with our safety guidelines at within within the manual and on the base of the battery. Failure to do so could result in injury or damage. Lipo batteries require completely different charging and care than NiCd and NiMH batteries and must be used with a LiPo specific charger. Misuse can result in fire, personal injury and/or damage to property. The user assumes all liability and risk associated with the use of Lithium-Polymer (Li-Po) batteries. Immediately return the battery, unused, if you do not agree with these terms).

WARNING! NEVER LEAVE THE BATTERY UNATTENDED WHILE ON CHARGE.

- The supplied charger can charge either 2s or 3s (cell number) LiPo batteries. The supplied battery is a 2s. Ensure you plug it into the correct 2s balance port.
- When the charger is connected to the mains power the three power LED's will turn green. Once you connect your balance connector to the charger the status LED's will turn Red indicating that charging is in progress (2 LED for 2S battery and 3 LED for 3S). Once the battery is fully charged the status LED's will turn green. If you experience the LED's blinking red then there is an error with either the battery or charger. When charging a completely discharged battery, the charger can become hot to touch.
- Always disconnect the charger from the mains supply and the battery pack when not in use.
- To install a charged battery into the vehicle, remove the body clips and remove the bodyshell. Loosen the velcro straps, insert battery and then tighten the straps so that they securely hold the battery inside the battery box. Make

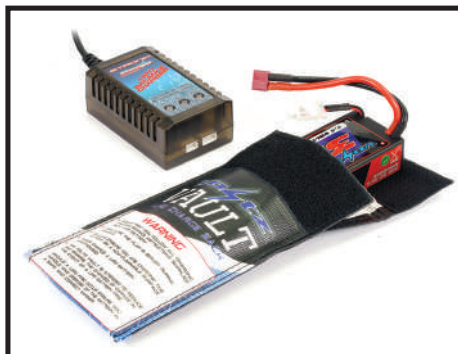
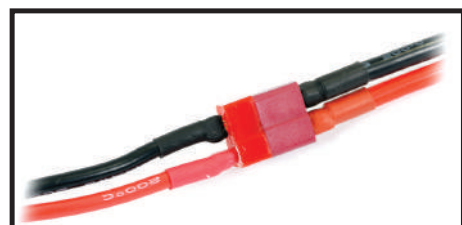
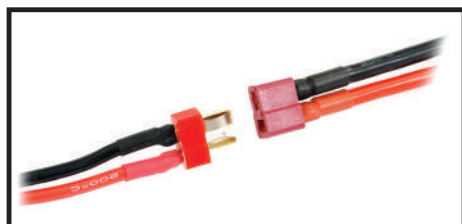

sure the model is switched off before connecting the male and female connectors.

- Always store your model with the battery pack unplugged and removed. Always charge your battery away from the vehicle. The included 300mAh mains charger will take approx 6 hours to charge a fully discharged battery, but always remove it from the charger if it becomes warm to the touch. Always disconnect the charger from the mains supply and the battery pack when not in use. Keep children away from charger and battery during the charging process.
- To install a charged battery, remove the body clips and remove the bodyshell. Remove the battery retainer clips, insert battery and re-install retainer with the flat side facing the battery and re-insert clips. When connecting battery and turning car on, ensure it is off the ground, with wheels away from objects.

Notes on Battery use:

- Always allow the battery cool after use, before recharging.
- Always inspect the battery before charging.
- Any bare wires, split heat shrink or leakage is a sure sign of abuse.
- Never attempt to charge dead or damaged batteries.
- Do not disassemble the battery or cut the connector wires.

- If the battery connector, battery case or cable insulation get hot enough to melt or split there is most likely a serious problem with your model, driveline, battery wires or speed controller. Find and correct the problem before installing another charged battery pack. (please refer to our detailed LiPo handling notes below).

LIPO BATTERY - USER SAFETY AND HANDLING INSTRUCTIONS.

- Read all safety instructions before charging or using your batteries for the first time.
- Lipo batteries require completely different charging and care than NiCd and NiMH batteries.
- Misuse can result in fire, personal injury and/or damage to property.
The buyer assumes all liability and risk associated with the use of Lithium-Polymer (Li-Po) batteries. Immediately return the battery, unused, if you do not agree with these terms.

General guidelines and warnings:

1. Use a Lithium Polymer specific chargers only! Do not use a NiCd or NiMH charger.
2. NEVER charge unattended. Always charge in safety sack or metal tin with lid and away from other flammable materials.
3. During the charge process watch for swollen or ballooning cells. If this happens immediately disconnect the charger and move the battery to a fire proof place for 15 minutes. Do not attempt to charge again.
4. A short circuit can cause a rapid discharge of high currents. Avoid short circuits, and be aware of short circuits on jewelery.
5. Any Lithium Polymer battery involved in a crash should be removed and observed in a fireproof space for 15 minutes before continuing to use or charge the battery.
6. If rewiring the battery pack, rewire the leads one at a time. Do not cut both leads. Do not short circuit on tools.
7. Do not expose battery packs to direct sunlight for extended periods.
8. Do not attempt to tamper with or open the LiPo Hardcase. The case is protection against possible battery swelling.

Before charging:

Visually inspect the pack checking for damaged leads, connectors, cracked heat shrink covering, swelling or other abnormalities. Do not charge if the pack is damaged.

Charging process:

1. NEVER charge unattended.
2. Charge away from flammable materials and inside a Lipo safe sack or metal tin with lid.
3. Allow battery to cool before charging.
4. Use the battery label for setting charger cell count and voltage.
5. Do not exceed 5C MAX charge rate. (Example, charge a 1000mAH pack at 5A MAX).

If disposing of a LiPo battery proceed as follows: Submerge the battery into a container filled with about 10 litres of salt water (one cup of salt in 10L). Leave the battery submerged for 2 weeks, this will slowly and safely discharge the battery until the voltage has dropped to zero volts which eliminates the risk of any chemical reaction. It can then be disposed of in the general waste collection.



OPERATING THE ELECTRONIC SPEED CONTROLLER

Thank you for your purchasing this Etronix product, the Photon 3.0 ESC is our new generation brushless electronic speed controller (RTR version). The high power systems for RC models can be very dangerous, we strongly suggest that you read this manual carefully before using your speed control. Etronix have no control over the use, installation, application, or maintenance of these products, thus no liability shall be assumed nor accepted for any damages, losses of costs resulting from the use of this item.

Caution

- Do not let children use this product without the supervision of an adult.
- The ESC might get hot during use, be careful when handling it.
- When soldering input/output wires and connections, set the iron to 60W minimum.
- Always disconnect the battery after use, do not store with the battery connected.
- Do not use near flammable materials.
- If the ESC overheats, emits smokes or burns, immediately discontinue use, disconnect the battery and seek assistance.

Features

- Completely water-proof and dust-proof.
- 32-bit microprocessor can support more powerful processing capability and more accurate motor output.
- Excellent start-up, acceleration and linearity features.
- Multiple protection features: Low voltage cut-off protection, over-heat protection and throttle signal loss protection.
- Be easily programmed with LED Program Card.

Specification

Product Name	Photon 3.0 50A G2	Photon 3.0 60A G2	Photon 3.0 120A SCT G2	Photon 3.0 150A G2
Cont. Current	50A	60A	120A	150A
Burst Current	300A	390A	780A	950A
Input Voltage	2-3S Lipo	2-3S Lipo	2-4S Lipo	2-6S Lipo
BEC Output	6V/3A(Switch BEC)	6V/3A(Switch BEC)	6V/3A(Switch BEC)	6V,7.4V/6A(Switch BEC)
Size(L*W*H)	48*38*32.5mm	48*38*32.5mm	56.5*38*33.5mm	55*48*37.5
Weight	94g	95.5g	100g	150g
ESC Programming Via	LED Program Card	LED Program Card	LED Program Card	LED Program Card
Firmware Upgrade	Not Supported	Not Supported	Not Supported	Not Supported
Waterproof	Supported	Supported	Supported	Supported
Car Applicable	1/10th Touring Cars/Buggies/ Trucks/Monster Trucks	1/10th Touring Cars/Buggies/ Trucks/Monster Trucks	1/10th SCTs/Truck/ Monster Truck	1/8th Touring Cars/Buggies/ Trucks/Monster Trucks

Connection

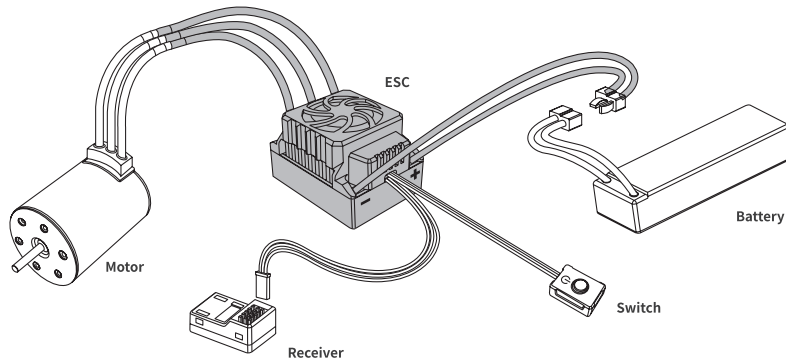

Battery Wire Connection

When connecting the battery, pay attention to polarity: incorrect connection will damage the ESC and Battery. As shown in the figure above, connect the positive (+) wire is connected to (+) battery port, and the negative (-) wire is connected to the (-) battery port.

Motor Wire Connection

The #A, #B, #C wires of the ESC can be connected with the motor wires freely (without any sequence). If the motor runs in the opposite direction, please swap any two wire connections.

Receiver Wire Connection

The signal wire supplies 6.0V to the receiver, servo, etc. So there is no need to connect an additional battery. External power connected to the receiver may damage the ESC.

Black wire	RX-
Red wire	RX+6.0V
White wire	RX-Signal

Software Functions and Settings

Power On/Off ESC

1. Press the power button then the ESC will be powered on.
2. Press and holding the power button until the all LEDs died out, then the ESC will be powered off.
(Note: Please place the throttle trigger on the neutral position: within 10%, otherwise the ESC can not be powered off.)

Throttle Calibration

1. Connect the ESC with the battery and receiver well, then turn on the transmitter.
2. Press and holding the power button until the blue LED is on solid, the motor have a long beep at the same time, then release the power button, the red led will be on solid, the ESC enters to the calibration mode.
3. Pull the throttle trigger to the full throttle position, the blue led blinks three times and the motor beeps once, the full throttle position is saved.
4. Push the throttle trigger to the full brake position, the blue led blinks three times and the motor beeps twice, the full brake position is saved.
5. Release the throttle trigger to the neutral position, the blue led blinks three times and the motor beeps three times, the throttle calibration is completed.
6. The ESC can support reverse throttle calibration, if the transmitter throttle set reverse (it means pull the throttle will go to 1000 throttle position/normally is 2000, and push the throttle will go to 2000 throttle position/normally is 1000), then you do the throttle calibration the same way as usual (as above), it will not have any effects on the ESC forward and revers way even if the transmitter throttle set reverse.



Please note: No need to restart the ESC again after throttle calibration finished. Do not move the throttle during the time of the blue led blinks.

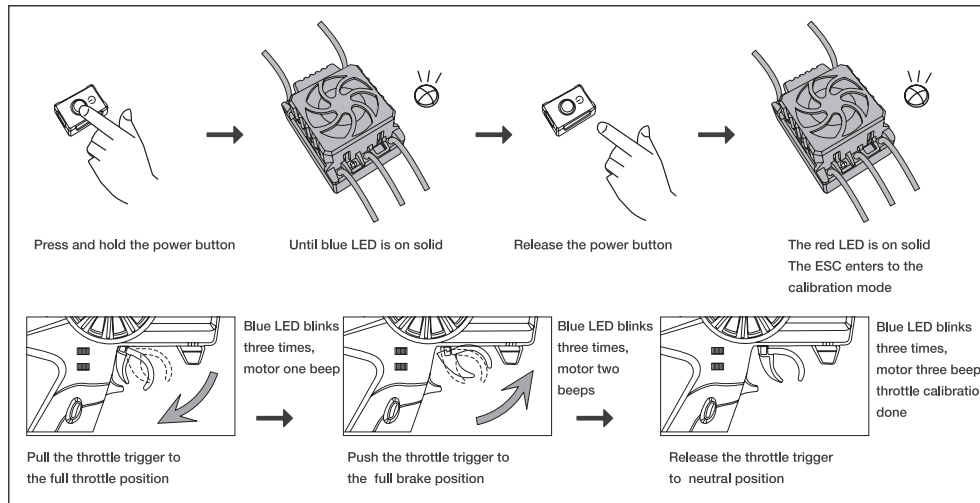

LED Program Card (OPTIONAL)

- How to connect
Connect the ESC with the battery, power on the ESC, then plug the ESC signal wire into the right socket of the LED, wait for two seconds until LED is on, you are ready to program.
- How to program
Press MENU button to select the main menu, press VALUE button to select the sub-menu, press OK button to confirm, press RESET button to reset. For example: if you want to set Neutral Range at 8%, press MENU button to select 03, and press VALUE button to select 02, then press OK button.
If you want to reset the ESC value, press the RESET button first, then press OK button.
Check the picture on the right for detail LED programmable value.

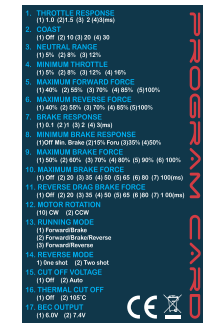

LED Status

1. During operation

Throttle Position	Blue LED	Red LED
Neutral	Blinking	OFF
Full Throttle	ON	ON
Full Brake	OFF	ON

Note: When you pull the throttle from neutral position to full throttle position, the Blue LED will blink, and the blink frequency will go faster when the throttle goes higher.

- When some protection is activated
 - The RED LED is always on solid once the power button is pressed.
 - The RED LED blinks, single flash between every one second. Repeat like "□ □ □" indicates that the voltage is abnormal.
 - The RED LED blinks, double flash between every one second. Repeat like "□□ □□ □□" indicates that the temperature is abnormal.
 - The RED LED blinks, single and double flash alternately between every one second. Repeat like "□ □□ □ □□ □□" indicates that both of the voltage and temperature is abnormal at the same time. The RED LED will not have any responds even the voltage or temperature is abnormal if not detect the signal.
 - The BLUE LED blinks, double flash between every two seconds. Repeat like "□□ □□ □□" indicates that the throttle is abnormal. (No throttle, or the throttle is not on the neutral position)

Throttle Signal

- The ESC can support the 450Hz maximum PPM throttle signal.
- The ESC throttle protection will be activated under the following situation, and the BLUE LED blinks double flash:
The throttle trigger do not place on the neutral position when the ESC turns on.
Lost the throttle signal.
- If the ESC lost throttle signal during the operation, the BLUE LED will blink double flash, and the ESC will start to work again until the throttle signal is back to normal.

Sensorless

- The PWM driving frequency will be selected automatically by the ESC on sensorless mode, and the manual setting is invalid.
- It is invalid to set the brake PWM frequency less than 1KHZ and forced recognized as 1KHZ, if the ESC is on sensorless mode.

Protection

- High Voltage Protection:
If the ESC detected the voltage too high(Higher than the esc standard voltage), when the ESC turns on, and the voltage protection was not set "OFF", then the voltage protection will be activated, and the maximum throttle output will be limited within 50%. (The high voltage protection only worked on the moment of the ESC turns on, and it will not work on the other stages even it detected the high voltage, once the high voltage protection opened, even though the voltage comes down to the normal voltage, the protection will not be relieved.)
- Low Voltage Protection:
If the ESC detected the voltage less than the set value at anytime, and this voltage keep for a while, then the low voltage protection is activated, and the maximum throttle output will be limited within 50%. (Once the low voltage protection activated, even though the voltage comes back to normal, the protection can not be relieved.)
- Thermal Protection:
The output throttle from the ESC will be limited (not over 50%) with the thermal value you have preset. (The Thermal protection will be dismissed when the ESC temperature drop to 65°C)
- If the voltage protection and temperature protection set off, and when the voltage and temperature become abnormal, the LED status will indicates the problems correspondingly but will not limit the throttle output and will not close all ESC timing.
- If the ESC detected the motor have the driving problem (like motor rotor locked or motor phase lost problem) which can cause the motor not run smoothly and when the throttle trigger leave neutral position for a while, then the ESC driving abnormal protection will be activated, and the motor will emit special tone like beep-beep-beep (note: some motors can not beep or beep with a low sound if motor have phase loss problem), and the protection will be closed until you released the throttle trigger to neutral position for 0.2 seconds.
If this problem occurs three times continuously, then you have to solve the motor driving problem first, or the protection will exist all the time.



Programmable Items Description

- Throttle Response:** It indicates how often the ESC performs throttle adjustment.
- Throttle Coast:** When the throttle value changes from high to low, it will decrease every 0.01 second. For example: the current throttle stick is at 80%, and the next moment is at 30%. If the throttle coast is not turned on, the throttle value will be immediately reduced from 80% to 30%. If it is turned on, the throttle value will be 80%, 70%... 30% dropped so slowly.
Note: If the throttle stick is at 0% at the next moment, the throttle value will be equal to 0 immediately. This item only works within the forward throttle range, and has the most obvious effect at 30% throttle.
- Neutral Range:** Throttle midpoint width, the range of the throttle stick in the centered state.
- Min. Throttle:** The minimum throttle, limit the throttle value can not be too small, this item can be adjusted according to the RC car configuration, the smaller the lighter car, this item can be adjusted down, so that the RC car can get a very low speed, the larger the heavier car, this item can be adjusted large, it can eliminate the jitter caused by insufficient starting power.
- Max. Forward force:** If it is set to 80%, the actual throttle value is 80% when the throttle stick is at 100% of the forward throttle.
- Max. Reverse force:** If it is set to 80%, the actual throttle value is 80% when the throttle stick is at the 100% position of the throttle in the reverse direction.
- Brake Response:** It indicates how often the ESC will perform the brake adjustment.
- Min. Brake Force:** It limits the minimum braking force.
- Max. Brake Force:** If the minimum braking force is set larger than the maximum braking force, the maximum braking force is equal to the minimum braking force.
- Fwd. Drag Brake Force:** It refers to the braking force when the throttle stick returns to the 0% position from the forward stroke after the RC car moves forward. If it is turned on, the ESC will turn on correspond brake force when the throttle stick at the 0% position.
- Rev. Drag Brake Force:** Rev drag braking force refers to the braking force when the throttle stick returns to the 0% position from the reverse stroke after the RC car moves backward.
- Motor Rotation:** In some RC cars, under the default rotation, forward and backward are reversed. At this time, setting another motor rotation can correct this error.
- Running Mode:** Running mode includes Forward/Brake, Forward/Brake/Reverse, Forward/Reverse.
- Reverse Mode:** Check the following picture for details.
- Cutoff Voltage:** Check the protection part.
- Thermal Protection:** Check the protection part.

Reverse Mode: One shot & Two shot (In the Forward/Brake/Reverse Mode)

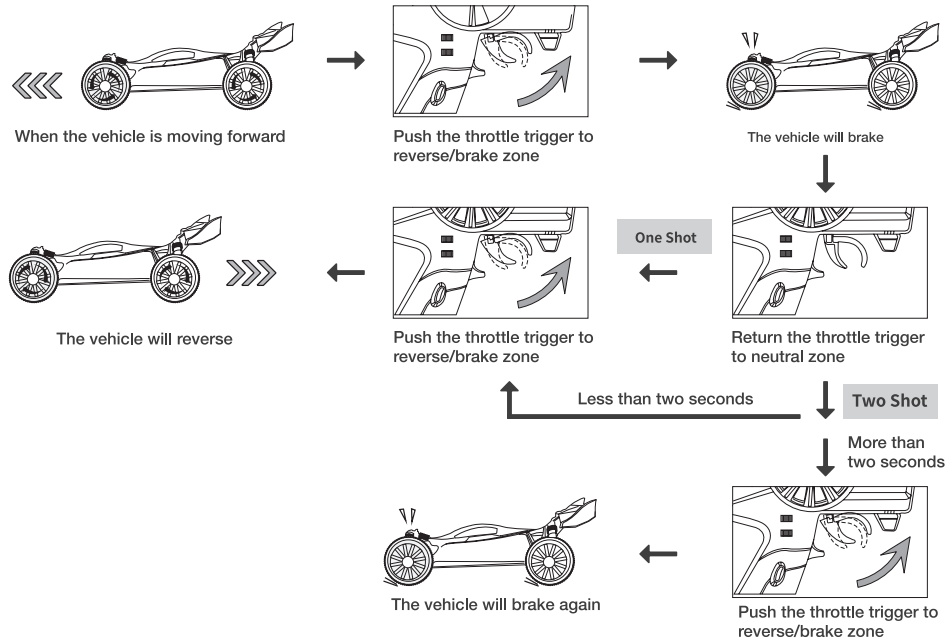

Trouble Shooting

Trouble Shooting	Possible causes	Solutions
The ESC was unable to start the status LED, the motor, and the cooling fan after it was powered on.	<ol style="list-style-type: none"> 1. No power was supplied to the ESC. 2. The ESC switch was damaged. 	<ol style="list-style-type: none"> 1. Check if all ESC & battery connectors have been well soldered or firmly connected. 2. Replace the broken switch.
The motor suddenly stopped or significantly reduced the output in operation.	<ol style="list-style-type: none"> 1. The receiver was influenced by some foreign interference. 2. The ESC entered the battery LVC (Low Voltage Cut off) protection. 3. The ESC entered the thermal (over-heat) protection. 	<ol style="list-style-type: none"> 1. Check all devices and try to find out all possible causes, and check the transmitter's battery voltage. 2. The RED LED blinks, single flash between every one second. 3. The RED LED blinks, double flash between every one second.
The motor stuttered but couldn't start.	<ol style="list-style-type: none"> 1. Some soldering between the motor and the ESC was not good. 2. The ESC was damaged (some MOSFETs were burnt). 	<ol style="list-style-type: none"> 1. Check all soldering points, please re-solder if necessary. 2. Contact the distributor for repair or other customer services.
The car ran forward/backward slowly when the throttle trigger was at the neutral position.	<ol style="list-style-type: none"> 1. The neutral position on the transmitter was not stable, so signals were not stable either. 2. The ESC calibration was not proper. 	<ol style="list-style-type: none"> 1. Replace your transmitter 2. Re-calibrate the throttle range or fine tune the neutral position on the transmitter.

ETRONIX
MOBIL ELECTRONIC

Etronix is a division of CML Distribution Limited, Saxon House, Saxon Business Park, Hanbury Road, Bromsgrove, Worcestershire, B60 4AD.
Email: sales@etronix-rc.com Web: www.etronix-rc.com



GETTING TO KNOW YOUR TRANSMITTER

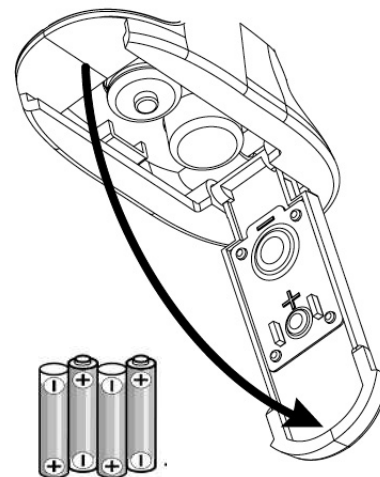
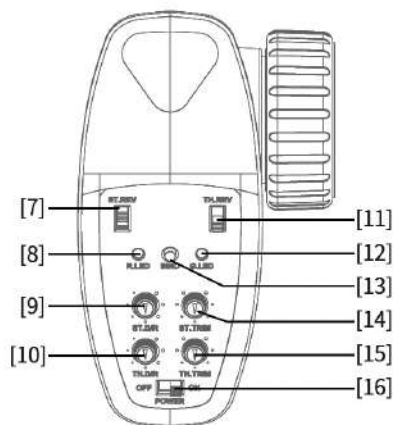
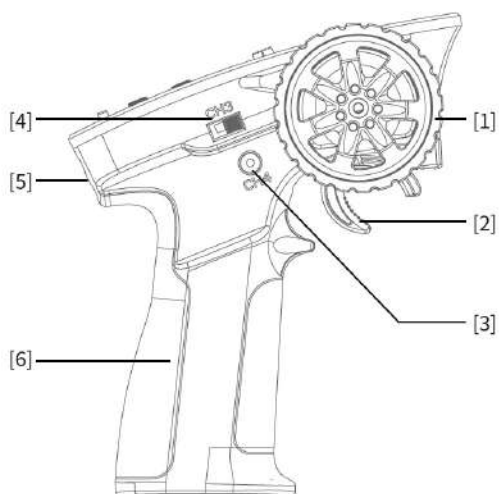

Base, 4x 1.5V AAA battery compartment

[1]	Traversing handwheel, 35 degrees on each side (CH1)	[9]	ST.D/R
[2]	Throttle button, 25 degrees in front and 12.5 degrees at rear (CH2)	[10]	TH.D/R
[3]	Push button switch (CH4) [Push button function is flip type]	[11]	TH.REV
[4]	Three-position toggle switch (CH3)	[12]	G.LED
[5]	Lanyard hole	[13]	BIND Button
[6]	Handle, 4*AAA battery compartment	[14]	ST.TRIM
[7]	ST.REV	[15]	TH.TRIM
[8]	R.LED	[16]	Power Switch

Receiver Overview

To ensure the best signal quality make sure that the receiver is mounted in such a way that the antenna is in the upright, vertical position.

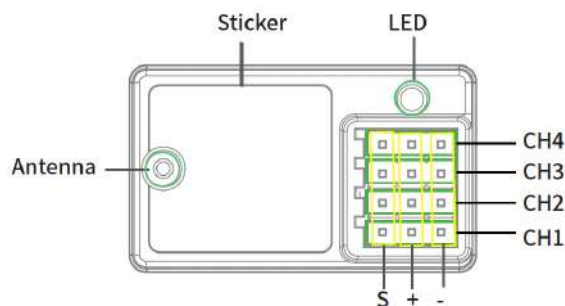

Battery installation

1. Open the battery compartment cover.
2. Insert 4 fully-charged AAA batteries into the compartment. Make sure that the battery makes good contact with the battery compartment's contacts and that they are inserted with the correct polarity.
3. Replace battery compartment cover.

NOTE:

The transmitter features a low battery alarm: When the battery is lower than 4.2v, the G.LED on the panel will flash slowly.

Binding

To ensure the best signal quality make sure that the receiver is mounted in such a way that the antenna is in the upright, vertical position.

The transmitter and receiver have already been bound at the factory.

1. Turn on the transmitter while holding the bind button to enter bind mode. G.LED will start flashing quickly. Once in bind mode release the bind button.
2. The receiver will enter bind mode automatically when powered on.
3. Once binding is successful the receiver's LED will flash slowly and the transmitter's LED will remain solid after being rebooted.

NOTE:

When binding, put the transmitter into bind mode first, then the receiver.

Stick Calibration

This function is used to set the neutral position for throttle and steering.

Every transmitter is calibrated before leaving the factory, however if recalibration is required, please follow these steps:

1. Turn and hold the wheel as far clockwise as it will turn, push the throttle trigger all the way forward, then turn on the transmitter in calibration mode.
 - The R.LED and G.LED will flash twice.
2. Calibrate steering: Turn the wheel completely clockwise, then completely counter-clockwise.
 - When calibration is complete the R.LED will turn off.
3. Trigger calibration: Pull the trigger back then forward as far as it will go.
 - When calibration is complete the G.LED will turn off.
4. Once calibration is complete press the bind key to save and exit.



RUNNING YOUR CAR

1. TURN ON THE RADIO CONTROLLER

Switch on the power switch on the radio controller. Your radio is bound with your car automatically.



2. TURNING ON THE RECEIVER OF YOUR CAR

The ESC Receiver switch is located under the bodyshell of the model. Switch on the ESC/Receiver Switch as shown in the picture.



3. CHECK STEERING PERFORMANCE

CENTRE

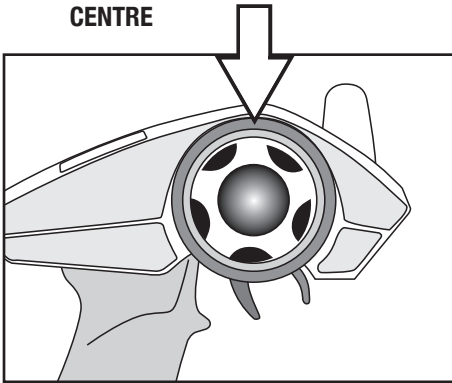

1. To keep the car running straight, keep the steering wheel centered.

TURN RIGHT

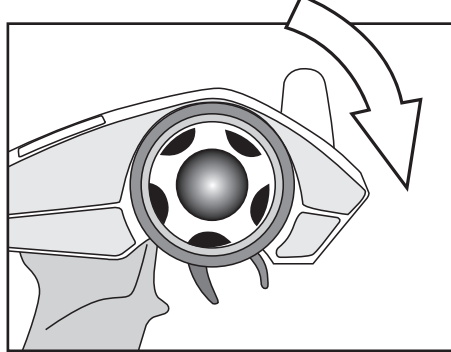

2. Turn the steering wheel to the right to allow the car to right.

TURN LEFT

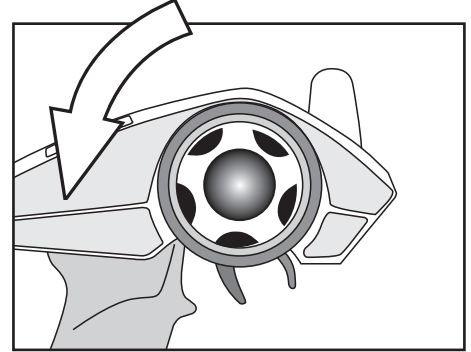

3. Turn the steering wheel to the left to allow the car to turn to the left.

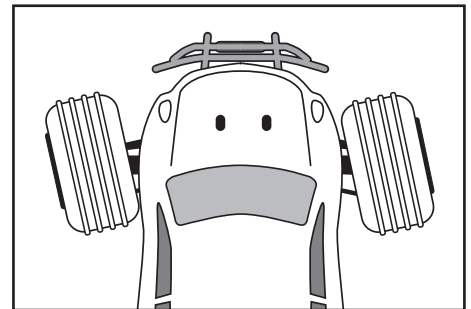
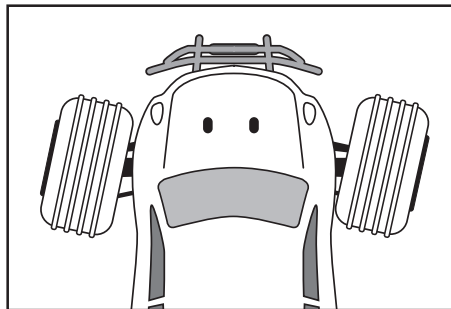
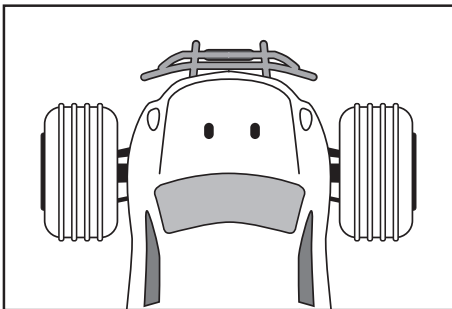

4. CHECK TRIGGER RESPONSE

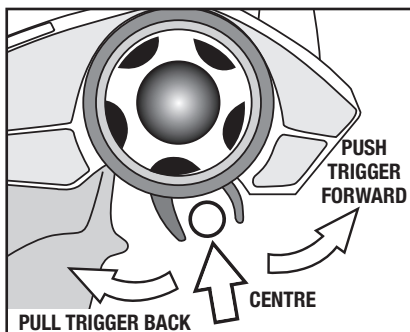

PLEASE NOTE: THE MODEL SWITCHES BETWEEN FORWARD AND REVERSE INSTANTLY FOR SLOW SPEED MANEOUVABILITY. EXCESSIVE USE OF THIS FEATURE CAN CAUSE TRANSMISSION AND ESC DAMAGE.

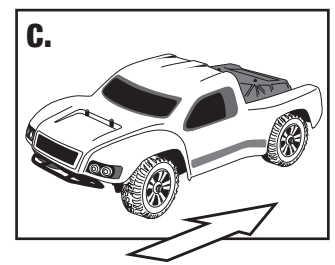
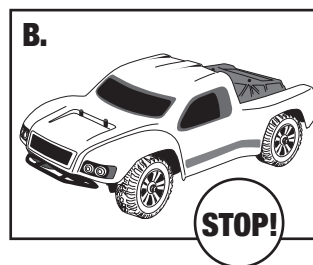
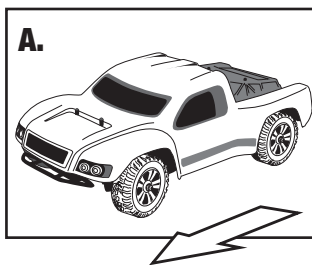

A. Pull the trigger back to accelerate, release it to decelerate.
B. To stop running your car, release the trigger to neutral.
C. Pushing the trigger forward activates reverse.



RUNNING YOUR CAR

5. TUNING THE STEERING TRIM

STEERING TRIM DIALS

Gently pull the trigger to allow your car to run slowly. Meantime, tune the steering trim to allow the front wheels to be aligned by rotating dial clockwise or anticlockwise.

Adjustment range: -120us - + 120us;

ST.TRIM: counterclockwise adjustment to increase the trim value. The maximum value is 120 us.

ST.TRIM: clockwise adjustment to decrease the trim value. The minimum value is -120 us.



STEERING

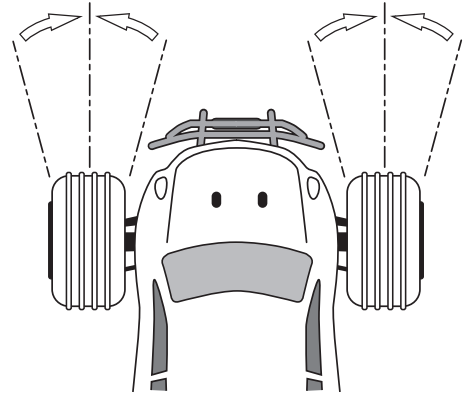

6. TUNING THE THROTTLE TRIM

THROTTLE TRIM DIAL

Throttle trim is used to set the idle speed of the car, by rotating dial clockwise or anticlockwise.

Adjustment range: -120us - + 120us;

TH.TRIM: counterclockwise adjustment to increase the trim value.

The maximum value is 120 us.

TH. TRIM-: clockwise adjustment to decrease the trim value.

The minimum value is -120 us.



THROTTLE TRIM

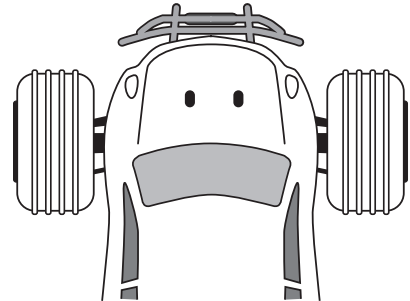

7. TO TUNE THE STEERING DUAL RATE CONTROL DIAL

STEERING D/R KNOB:

The dial marked "ST/DR" is for servo travel adjustment.

You should adjust this to give maximum steering without straining the servo.

Adjustment range: 0-120%;

ST.D/R: counterclockwise adjustment to increase the servo amount. The maximum value is 120%.

ST.D/R: clockwise adjustment to decrease the servo amount. The minimum value is 0%.



STEERING D/R

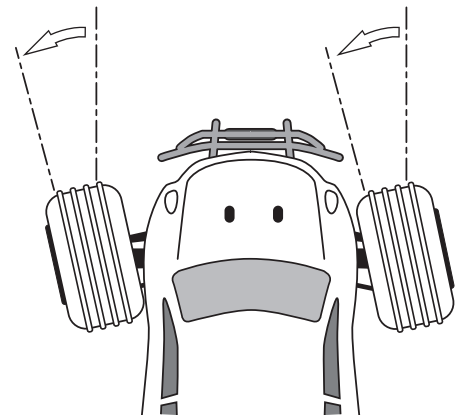

8. STEERING/THROTTLE REVERSE

This function is used to adjust each channels direction of movement in relation to it's input .

The ST.REV/TH.REV switches are the reverse buttons for CH1 and CH2.

If the switch is up it indicates reverse, down indicates normal..





PLEASE NOTE:

Although the electronics are waterproof the rest of car can be subjected to damage if running in excessively wet or submerged conditions.

After Run.

Switch off the receiver power, switch off the transmitter and lower the aerial. Disconnect the battery and remove it from the vehicle, allow it to cool before recharging. If you have a second charged battery all ready to use, still allow the vehicle to cool slightly before continuing.

Regular maintenance.

Frequently check the whole vehicle for loose or missing fixings. Use thread lock on any replacement screws into metal threads.

Frequently check rotating parts are free from grass, string etc. that might bind their motion and over stress the motor or speed controller. Remove the wheels occasionally and check behind the mounting hex for obstructions or anything that might have been wrapped around the axle and caused extra drag.

Check the gear mesh frequently and remove any stones or grit from gear teeth to prevent premature wear and damage.

If the motor moves, or is removed for maintenance/exchange, the gear mesh will need to be set. Simply slacken the motor retaining screws and adjust the motor between pinion and spur teeth. If the gear is too tight or too loose the gears will be noisy and could be damaged.

Shock absorbers will wear prematurely if used in dirty dusty conditions. Replace oil and seals as required to keep a smooth dampening action.

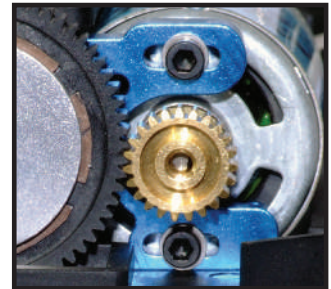

Trouble shooting guide.

<p>Short Runtime: Battery damaged/not charged Motor dirty or brushes worn Drivetrain binding</p>	<p>Sluggish Action: Motor dirty or brushes worn Bind in drive train Battery running low on power</p>	<p>Motor/ESC overheat: Over-gearred Binding transmission. Seized axle bearing. Motor binding</p>	<p>Motor spins but vehicle refuses to move: Gears damaged. Gears loose on shaft. Slipper clutch too loose. Drive shaft broken or missing.</p>	<p>Poor Range or fails to operate: Transmitter batteries low Vehicle Battery Low. Transmitter switched off Transmitter/receiver aerial not extended. ESC switched off or battery not connected. Loose connectors/wires. Water damage. Model electronics are not waterproof.</p>
--	--	---	--	---

Warranty

Due to the nature of this product and potential use FTX warrants it to be free of material and workmanship defects when new. FTX will at its sole discretion repair or replace defective components free of charge within 30 days from date of purchase. This warranty does not cover wear and tear, crash or impact damage, modifications, component water damage failure to perform maintenance or damage from improper use. Proof of purchase date will be required to action any warranty claims. In no case shall FTX's liability exceed the original cost of the purchased kit.

Instructions for disposal.

Environmental Protection Notes & WEEE

The crossed-out wheeled bin symbol shown here, which may be found on the product itself, in the operating instructions or on the packaging, is in accordance with the Waste Electrical and Electronic Equipment (WEEE) Directive. Individual markings indicate which materials can be recycled and re-used. You can make an important contribution to the protection of our common environment by re-using the product, recycling the basic materials or recycling redundant equipment in other ways.

When this product comes to the end of its useful life, you must not dispose of it in the ordinary domestic waste. Many electrical items that we throw away can be repaired or recycled. Recycling items helps to save natural resources and also reduces the environmental and health impacts that are linked with sending electrical goods to landfill. The correct method of disposal is to take it to your local collection point for recycling electrical and electronic equipment. You can go to recycle-more.co.uk for details of locations.

Alternatively FTX can offer our customers free take-back of their WEEE on a like-for-like basis when they buy a new Electrical or Electronic product from us. For example, if a customer bought a new radio system from us or a dealer, we would accept their old radio and prevent it going into a landfill site by disposing of it safely. Customers must return their old WEEE item to us within 28 days of purchasing their new item.

Remove batteries from your device and dispose of them at your local collection point for batteries. If you don't know the location of your nearest disposal centre, please enquire at your local council office.



CML Distribution, Saxon House, Saxon Business Park, Hanbury Road, Bromsgrove, B60 4AD. WEE/GB4215VX





EXPLODED PARTS DIAGRAM

FRONT SHOCKS

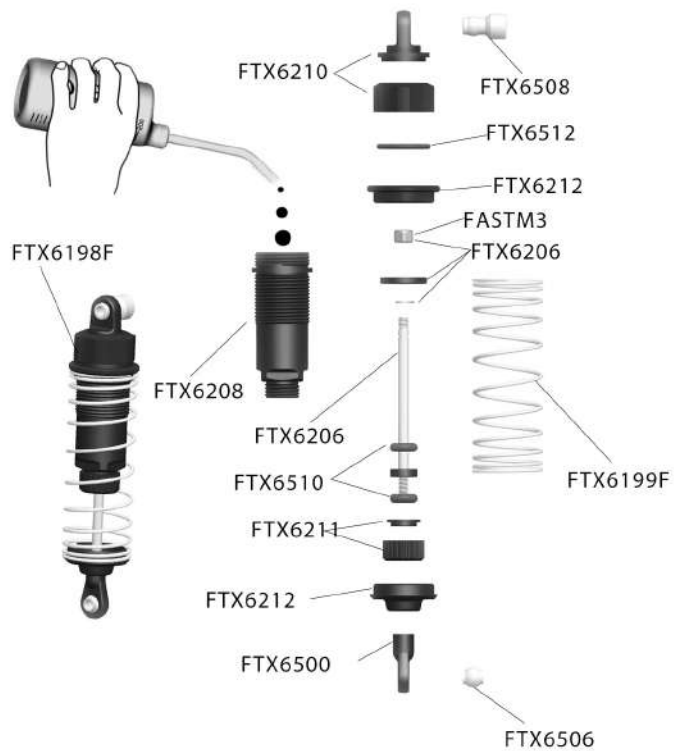

REAR SHOCKS

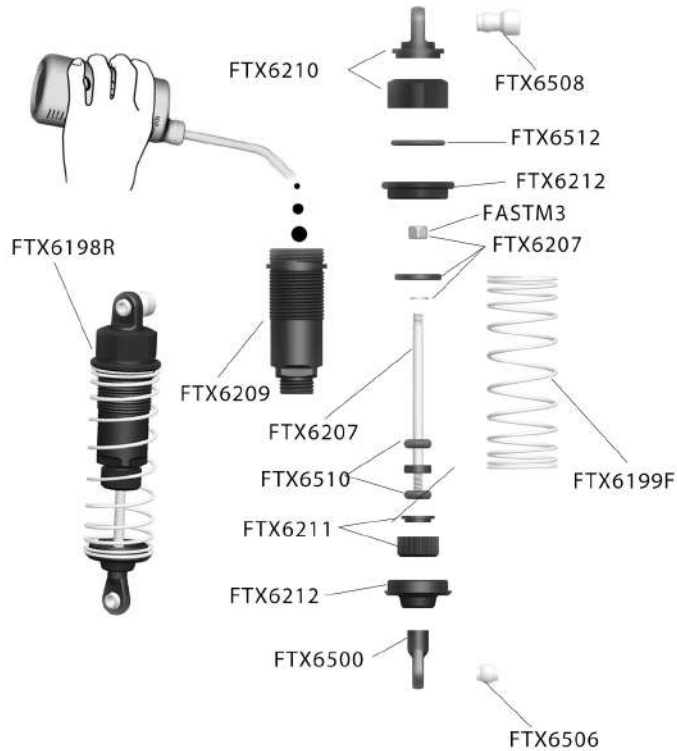

GEARBOX ASSEMBLY

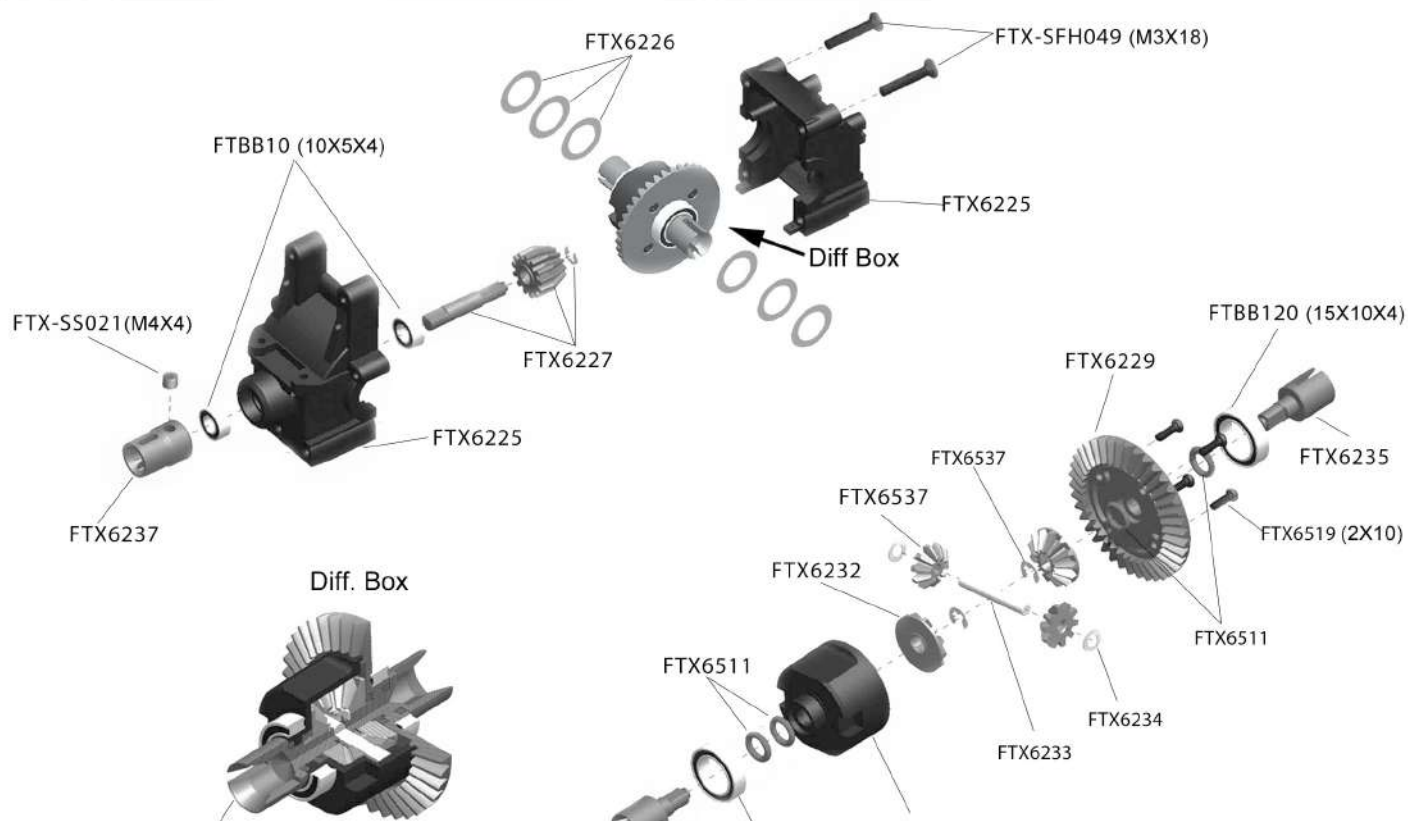



EXPLODED PARTS DIAGRAM

MOTOR ASSEMBLY

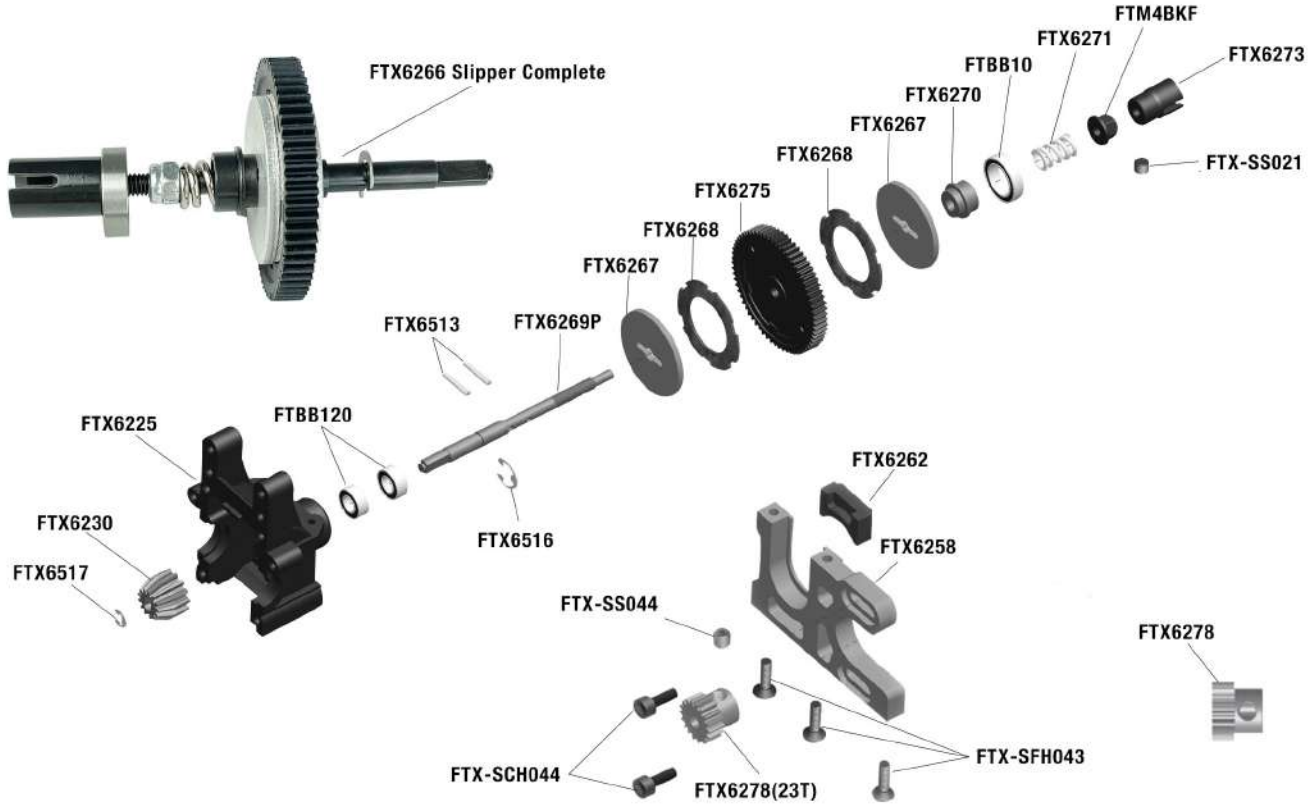

CENTRAL CHASSIS ASSEMBLY

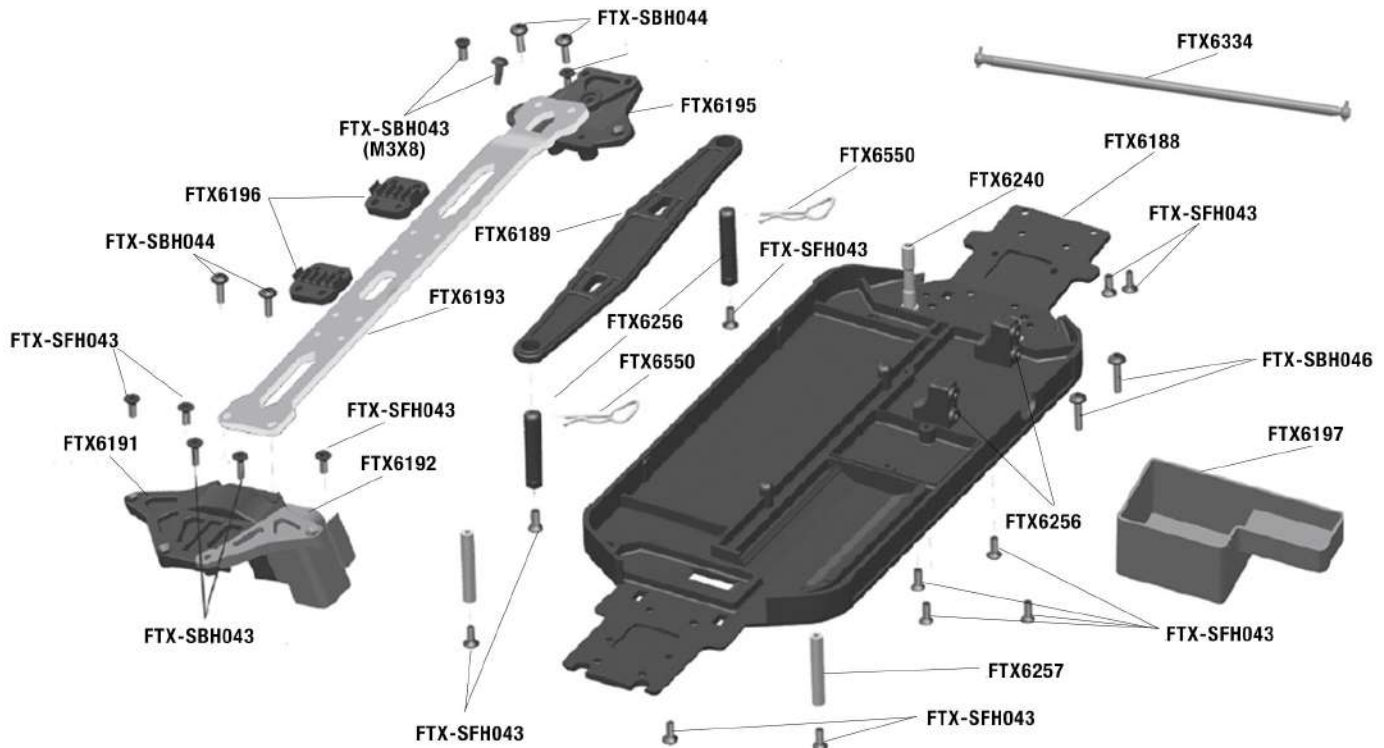



BUGGY SWAY BAR

**SWAY BAR IS AN OPTION ACCESSORY
AND NOT INCLUDED - FTX6375**

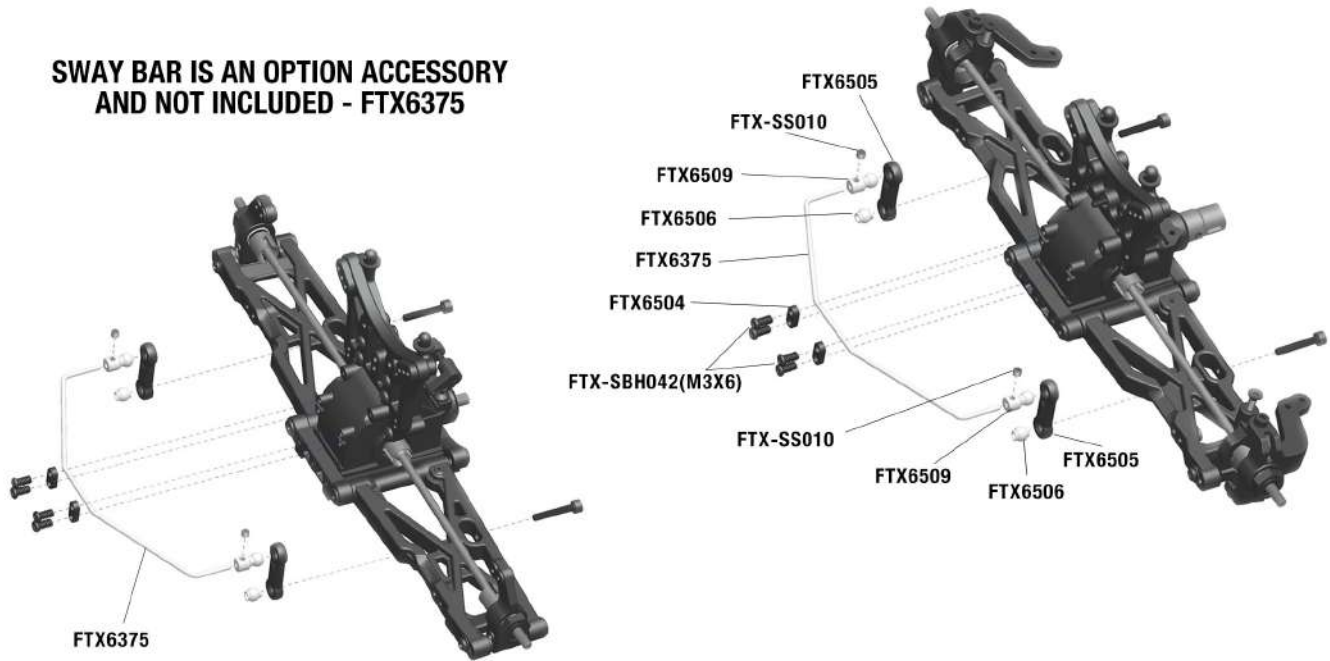

STEERING ASSEMBLY

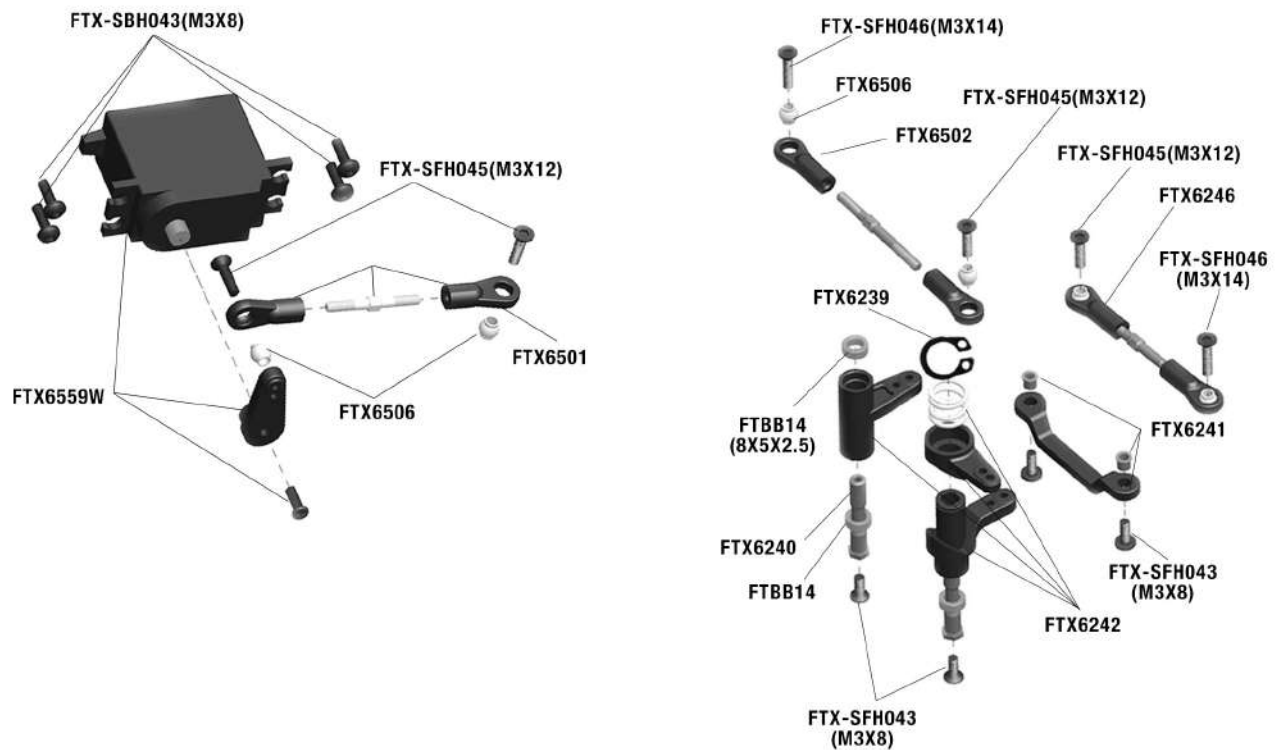



SPARE PARTS DIAGRAM

<p>FTX6450</p>  <p>Front Shock Tower 1pc</p>	<p>FTX6451</p>  <p>Rear Shock Tower 1pc</p>	<p>FTX6198F</p>  <p>Front Shocks 2pcs</p>	<p>FTX6198R</p>  <p>Rear Shocks 2pcs</p>
<p>FTX6199F</p>  <p>Front Shock Spring 2pcs</p>	<p>FTX6199R</p>  <p>Rear Shock Spring 2pcs</p>	<p>FTX6206</p>  <p>Front Shock Shaft & Piston Set 2 sets</p>	<p>FTX6207</p>  <p>Rear Shock Shaft & Piston Set 2 sets</p>
<p>FTX6208</p>  <p>Front Shock Body 2pcs</p>	<p>FTX6209</p>  <p>Rear Shock Body 2pcs</p>	<p>FTX6210</p>  <p>Shock Upper Cap 2 Sets</p>	<p>FTX6211</p>  <p>Shock Lower Cap 2 Sets</p>
<p>FTX6212</p>  <p>Shock Lower Holder & Adjust Ring 2 sets</p>	<p>FTX6215</p>  <p>Steering Knuckle Arms 2 sets</p>	<p>FTX6216</p>  <p>Hub Carrier Uprights 2pcs</p>	<p>FTX6217</p>  <p>Hub Carrier Uprights 2pcs</p>
<p>FTX6213</p>  <p>Rear Drive Axles 2pcs</p>	<p>FTX6987</p>  <p>Front Cast Aluminium Suspension Holders (2pc)</p>	<p>FTX6190</p>  <p>Rear Cast Aluminium Suspension Holders (2pc)</p>	<p>FTX6225</p>  <p>Gearbox Housing Set 2pcs</p>



SPARE PARTS LIST

<p>FTX6226</p>  <p>Diff. 16T Gear Washer 6pcs</p>	<p>FTX6227</p>  <p>Diff. Gear w/pin 2 sets</p>	<p>FTX6236</p>  <p>Diff. Gearbox Set 1 set</p>	<p>FTX6228</p>  <p>Diff. Case 2pcs</p>
<p>FTX6229</p>  <p>Diff. Drive Spur Gear</p>	<p>FTX6230</p>  <p>Diff. Drive Gear 2pcs</p>	<p>FTX6231</p>  <p>Diff. Bevel Gear S. 4pcs</p>	<p>FTX6232</p>  <p>Diff. Bevel Gear B. 4pcs</p>
<p>FTX6233</p>  <p>Diff. Pin 2pcs</p>	<p>FTX6234</p>  <p>Washer 6pcs</p>	<p>FTX6235</p>  <p>Diff. Drive Cup</p>	<p>FTX6237</p>  <p>Center Coupler 3pcs</p>
<p>FTX6240</p>  <p>Servo Saver Posts 2pcs</p>	<p>FTX6241</p>  <p>Steering Ackerman</p>	<p>FTX6224</p>  <p>Wheel Hub 4pcs</p>	<p>FAST103</p>  <p>Antenna Pipe Set 2 sets</p>
<p>FTX6286</p>  <p>Buggy Rear Wing (Black) 1pc</p>	<p>FTX6285</p>  <p>Buggy Rear Wing (Clear) 1pc</p>	<p>FTX6187BL</p>  <p>Printed Body Blue</p>	<p>FTX6187C</p>  <p>Clear Body & Decal</p>



SPARE PARTS LIST

FTX6269P  Slipper Shaft (EP) 1 set	FTX6270  Slipper Spring Bracket (EP) 1pc	FTX6271  Slipper Spring (EP) 1pc	FTX6242  Servo Saver (EP) 1 set
FTX6273  Slipper Drive Cup 1pc	FTX6262  Bearing Bracket (EP) 1pc	FTX6278  Pinion Gear (EP) 23T 1pc	FTX6196  Cable plate
FTX6188  Chassis Plate (EP) 1pc	FTX6191/6192  L/R Spur Gear Covers	FTX6193  Upper Plate (EP) 1pc	FTX6334  Center Drive Shaft (EP) 1pc
FTX6550  Body Clip (med) 6pcs	FTX6551  Body Clip (small) 6pcs	FTX6500  Shock Ball End 6pcs	FTX6501  Servo link Ball End 6pcs
FTX6502  Steering Link Ball End 6pcs	FTX6503  Rear Upper Link Ball End 6pcs	FTX6504  Sway Bar Fix Plate 6pcs	FTX6505  Sway Bar Holders 6pcs



SPARE PARTS LIST

FTX6222  Front CVD 2 Sets	FTX6195  Upper Chassis Brace 1pc	FTX6254  Buggy Front Bumper 1pc	FTX6218  Front Lower Susp. Arms 2pcs
FTX6219  Rear Lower Susp. Arms 2pcs	FTX6252  Wing Bracket 1 set	FTX6251  Wing Holder 1 set	FTX6250  Buggy Body Mount 1 set
FTX6243  Servo Linkage 1pc	FTX6244  Upper Front Susp. Arm 2 sets	FTX6245  Rear Upper Arm 2 sets	FTX6246  Steering Arm 2 sets
FTX6214  Rear Driveshafts (pr)	FTX6243  Upper Front Susp. Arm 2 sets	FTX6245  Rear Upper Arm 2 sets	FTX6246  Steering Arm 2 sets
FTX6189  Battery Cover (EP) 1pc	FTX6256  Battery Posts 2 sets	FTX6257  Rear Spur Gear Cover Post 2pc	FTX6258  Motor Mount (EP) 1pc
FTX6266  Slipper Complete (EP) 1 set	FTX6267  Slipper plates(EP) 2pcs	FTX6268  Slipper Pad (EP) 2pcs	FTX6275  Spur Gear (EP) 65T 1pc























SPARE PARTS LIST

<p>FTX6506</p>  <p>Ball A 6pcs</p>	<p>FTX6507</p>  <p>Ball B 6pcs</p>	<p>FTX6508</p>  <p>Ball C 6pcs</p>	<p>FTX6509</p>  <p>Ball D 6pcs</p>
<p>FTX6510</p>  <p>Shock O-Ring Lower 6pcs</p>	<p>FTX6511</p>  <p>Diff. O-Ring Seal 6pcs</p>	<p>FTX6512</p>  <p>Shock O-Ring Upper 6pcs</p>	<p>FTX6513</p>  <p>Pin 2x10 6pcs</p>
<p>FTX6514</p>  <p>Pin 2x11 6pcs</p>	<p>FTX6223</p>  <p>Hinge Pins (long & short) 1set</p>	<p>FTBB10</p>  <p>Ball Bearing 15x10x4 1pc</p>	<p>FTBB120</p>  <p>Ball Bearing 10x5x4 1pc</p>
<p>FTBB14</p>  <p>Ball Bearing 8x5x2.5 1pc</p>	<p>FTX6515</p>  <p>E-Clip 8mm 4pcs</p>	<p>FTX6516</p>  <p>E-Clip 4mm 4pcs</p>	<p>FTX6517</p>  <p>E-Clip 2.5mm 6pcs</p>
<p>FASTM3</p>  <p>Ny-Lock Nut M3 6pcs</p>	<p>FASTM4</p>  <p>Ny-Lock Nut M4 6pcs</p>	<p>FTX6518</p>  <p>Round Head Self-Tapping Hex Screw 2x10 6pcs</p>	<p>FTX6519</p>  <p>Round Head Self-Tapping Hex Screw 2x10 6pcs</p>









SPARE PARTS LIST

<p>FTX6520</p>  <p>Round Head Self-Tapping Hex Screw 3x15 6pcs</p>	<p>FTX6522</p>  <p>Round Head Self-Tapping Hex Screw M3x6 6pcs</p>	<p>FTX-SBH043</p>  <p>Button Head Hex Screw M3x8 6pcs</p>	<p>FTX-SBH044</p>  <p>Button Head Hex Screw M3x10 6pcs</p>
<p>FTX-SBH045</p>  <p>Button Head Hex Screw M3x12 6pcs</p>	<p>FTX-SBH046</p>  <p>Button Head Hex Screw M3x14 6pcs</p>	<p>FTX6530</p>  <p>Ring Self-Tapping Screw 3x4 6pcs</p>	<p>FTX-SS010</p>  <p>Set Screw M3x3 6pcs</p>
<p>FTX-SS021</p>  <p>Set Screw M4x4 6pcs</p>	<p>FTX-SBH044</p>  <p>Button Head Hex Screw M3x10 6pcs</p>	<p>FTX-SCH0043</p>  <p>Cap Head Hex Screw M3x8 6pcs</p>	<p>FTX6542</p>  <p>Cap Head Shoulder Screw M3x10 6pcs</p>
<p>FTX-SCH044</p>  <p>Cap Head Hex Screw M3x10 6pcs</p>	<p>FTX-SCH046</p>  <p>Cap Head Hex Screw M3x14 6pcs</p>	<p>FTX-SCH047</p>  <p>Cap Head Hex Screw M3x15 6pcs</p>	<p>FTX-SCH049</p>  <p>Cap Head Hex Screw M3x18 6pcs</p>
<p>FTX-SCH053</p>  <p>Cap Head Hex Screw M3x25 6pcs</p>	<p>FTX-SCH055</p>  <p>Cap Head Hex Screw M3x28 6pcs</p>	<p>FTX-SFH043</p>  <p>Flat Head Hex Screw M3x8 6pcs</p>	<p>FTX-SFH044</p>  <p>Flat Head Hex Screw M3x10 6pcs</p>



SPARE PARTS LIST

<p>FTX-SFH045</p>  <p>Flat Head Hex Screw M3x12 6pcs</p>	<p>FTX-SFH046</p>  <p>Flat Head Hex Screw M3x14 6pcs</p>	<p>FTX-SFH049</p>  <p>Flat Head Hex Screw M3x18 3pcs</p>	<p>FTX-SFH050</p>  <p>Flat Head Hex Screw M2x20 6pcs</p>
<p>FTX-SFH059</p>  <p>Flat Head Hex Screw M3x36 6pcs</p>	<p>FTX6197</p>  <p>Receiver/ESC Case</p>	<p>FTX6239</p>  <p>Servo Saver E-Clip</p>	<p>FTX6543</p>  <p>M4 x 10mm Drop Set Screws</p>
<p>ET0132FTX</p>  <p>Photon 3.0 50Amp</p>	<p>FTX6559W</p>  <p>3kg/cm Servo 1pc</p>	<p>ET0335</p> <p>(Brushless version)</p>  <p>2950kv Brushless Motor 1pc</p>	<p>VZ0305</p> <p>(Brushless version)</p>  <p>Li-Po 3200mAh 7.4V Cell Pack 1pc</p>
<p>ET0223</p> <p>(Brushless version)</p>  <p>Li-Po Balance Charger</p>	<p>FTX6300T</p>  <p>Front Stub Tyre w/Inserts (pr)</p>	<p>FTX6301T</p>  <p>Rear Stub Tyre w/Inserts (pr)</p>	<p>FTX6307F</p>  <p>Front Split Spoke Black Wheels (pr)</p>
<p>FTX6307R</p>  <p>Rear Split Spoke Black Wheels (pr)</p>	<p>FTX6302F</p>  <p>Front Stub Tyre Mounted on Wheels (pr)</p>	<p>FTX6302R</p>  <p>Rear Stub Tyre Mounted on Wheels (pr)</p>	<p>ET1063 ET1064</p> <p>ET1063 EX4M Transmitter ET1064 EX4M Receiver</p> 



UPGRADE OPTION PARTS LIST

<p>FTX6387</p>  <p>Carbon Front Shock Plate 1 set</p>	<p>FX6388</p>  <p>Carbon Rear Shock Plate 1 set</p>	<p>FTX6354</p>  <p>Carbon Battery Cover 1pc</p>	<p>FTX6348</p>  <p>Chassis dust cover</p>
<p>FTX6356</p>  <p>Aluminium Front Shocks 2pcs</p>	<p>FTX6357</p>  <p>Aluminium Rear Shocks 2pcs</p>	<p>FTX6360</p>  <p>Alum. Steering Ackerman 1pc</p>	<p>FTX6361</p>  <p>Alum. Front Susp. Holders 1 set</p>
<p>FTX6362</p>  <p>Alum. Rear Susp. Holders 1 set</p>	<p>FTX6363</p>  <p>Alum. Rear Hub carriers 2pcs</p>	<p>FTX6375</p>  <p>Sway Bar 2 sets</p>	<p>FTX6365</p>  <p>Aluminium Wheel Hub 4pcs</p>
<p>FTX6373</p>  <p>Aluminium Heat Sink 1pc</p>	<p>FTX6366</p>  <p>Wheelie Bar 1 set</p>	<p>FTX6367</p>  <p>Aluminium Steering Arms 2pcs</p>	<p>FTX6368</p>  <p>Aluminium Knuckle Arm 2pcs</p>
<p>FTX6350</p>  <p>Chassis Plate (Alum./Carbon) 1set</p>	<p>FTX6389</p>  <p>Rear CVD Driveshafts</p>	<p>FTX6371</p>  <p>Alum. Lower Susp. Arms 2pcs</p>	<p>FTX6372</p>  <p>Rear Lower Susp. Arms 2pcs</p>