

# 1:14 Electric four drive big-legged car

14+



Caution: This model is not a toy, it is designed for user over 14 years of age.

Please use this instruction and the R/C system instruction at the same time.

The instruction is suitable for a type of model whose number is 144002

Safety and caution .....	1-2
Troubleshooting • Product introduction .....	2-3
Instruction of common tools and installation the electronic part...	3-4
Practice and maintenance.....	5
Assemble exploded view .....	6-16
Fittings view .....	17-22

## Safety and Cautions

- \*Never run the model on public roads or streets, as it could interfere with traffic.
- \*To prevent property damage and/or personal injury. Never run the model in crowded areas, near or toward people or animals.
- \*Never run the model near rivers, ponds or lakes.
- \*Make sure that no one else is using the same frequency in your running area. Using the same frequency at the same time, can cause loss of control with R/C model, resulting in serious accidents.
- \*To avoid a runaway R/C model or loss of control always follow the procedure below;
  1. Fully extend transmitter antenna.
  2. Switch the transmitter on.
  3. Switch on the R/C model.
- \*Follow reverse procedure to shut down.
- \*Never touch or block rotating tire.
- \*Never run R/C model in the rain or in puddles, as water may cause trouble with R/C model.
- \*Motor and battery get very hot after running. Take care when handle them.
- \*Retract transmitter antenna when not in use.
- \*Remove the batteries from model and transmitter when they are not in use.



## Cautions when handling batteries

- \*Do not dismantle the battery or charger and do not cut and battery cables. Altering the battery may cause short-circuit and/or damage to the product.
- \*Charge battery with compatible charger following proper procedure outlined in the instructions. Do not modify charger or charge battery in improper way.
- \*Do not recharge battery if it is still warm from use as it may damage the battery. Allow the battery to cool off prior to recharging.
- \*Make sure to disconnect charger from R/C model and electrical outlet when not in use.
- \*Remove transmitter battery when not using it for a long period of time as it may leak and damage transmitter.
- \*Never incinerate used batteries, as they can explode causing serious accidents.



## Safety precautions

Do not operate the model on public roads, in crowded places or near infants, it may cause accidents or injury.

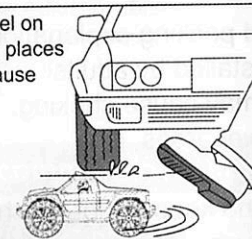

The product includes small and sharp parts, assemble and store this product only in places out of the reach of children.

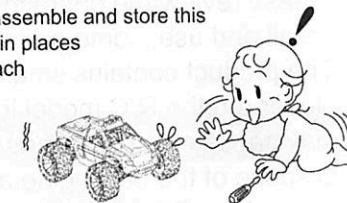

The front end of the antenna may be dangerous, do not aim it toward faces.



During and after operation, the motor will be hot. Please do not touch it until it has had time to cool down.

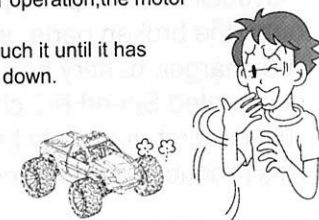

When multiple vehicles are being operated nearby, Ensure that each vehicle and controller pair are set to different frequencies. Or else the car will lose control and may lead to damage, serious accidents or injury.

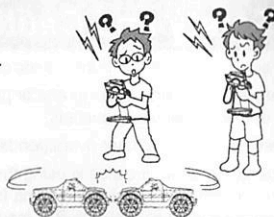

## Troubleshooting

Description	Cause	Solution
The car does not operate at all.	Transmitter or receiver is off.	Turn on both transmitter and receiver.
	Batteries are not installed properly in the transmitter.	Place batteries in the transmitter properly.
	The drive battery is not charged enough.	Charge the drive battery.
The car does not follow your operation and control distance is not long enough.	Someone else is using the same radio frequency as you are using.	Change your radio frequency to the one no one else is using, wait until the driver using the same radio frequency finishes driving, or drive your car at a different place.
	There is not enough power in the transmitter or receiver batteries.	Replace the transmitter batteries with new ones and charge the drive battery.
	Antenna not fully tightened on the transmitter/not fully extend.	Make sure to insert the antenna into the transmitter and fully extend the antenna.



## CAUTION

- \* Please review the operation manual and packing explanation to install and use, some parts should be installed by adults.
- \* The product contains small part, which may cause choking.
- \* Never run the R/C model in the rain or wet areas, it may cause electronic parts to malfunction.
- \* Dispose of the package appropriately and keep out of reach of children.
- \* Inspect the RC car for damage to the charge, wire, plug, bodyshell or other parts prior to operation. If damage is found, repair the broken parts before use.
- \* The charger, battery box and battery must be only be used with the designated Speed RC changing system.
- \* This product must only be used with the original Speed RC charger.
- \* This product may be dangerous to the children.

## Proportional R/C Using Instruction

- ① Turn the steering wheel left, the car will turn left. Steering angle can be adjusted by increasing/decreasing the degree of wheel rotation.

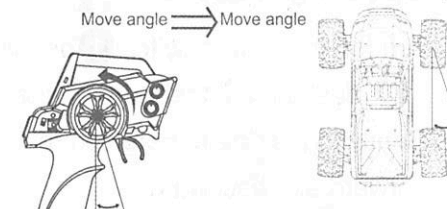

- ② Turn the steering wheel right, the car will turn right. Steering angle can be adjusted by increasing/decreasing the degree of wheel rotation.

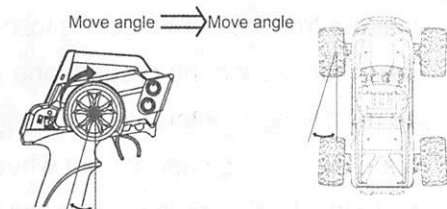

- ③ Pull the throttle trigger backward, the car will drive forward. Adjusting the angle of throttle trigger can adjust forward speed of the car. To stop the car, quickly push the trigger forward.

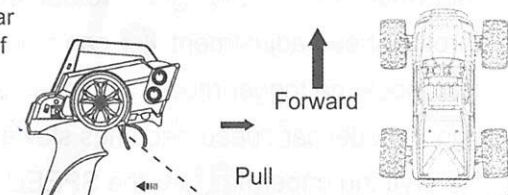

- ④ Loosen the trigger to allow it return the neutral position. Push the throttle trigger forward, the car will reverse. Adjusting forward angle of throttle trigger adjust reverse speed of the car.

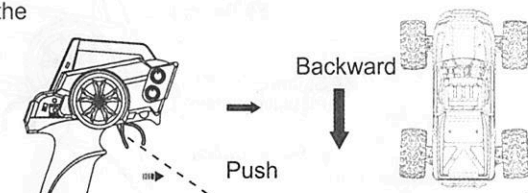

## Introduce the common tools and assemble the electron parts

### Tools needed for assembly

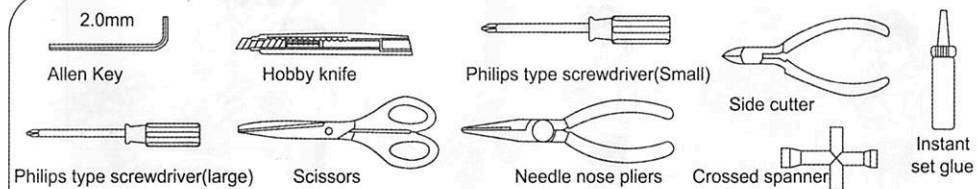

## PRACTICE AND MAINTENANCE

### Operating program

1. Turn on the power switch **1** on the remote and make sure the power indicator **2** flashes red, then turn on the model car's power switch.
2. Gently trigger the remote control to observe if the car can move forward and backward.
3. Turn the remote control steering wheel **4** to the left or right and make sure that the front wheel's steering follows the command.
4. The model car on the ground, and standing behind the model car, gently hook the remote control throttle trigger **3**, if the model car does not go straight, rotate the remote control front wheel trim **5**, the model car to the right side, the front wheel Turn the trim to the left, the model car leans to the left, and the front wheel trims to the right to rotate until the model car can go straight.
5. Throttle speed adjustment **6** can adjust the model car speed, rotate to the right, hook the trigger model car speed becomes faster, turn left, hook the trigger model car speed becomes slower.
6. If everything operates OK, the SPEED RC is ready to run.

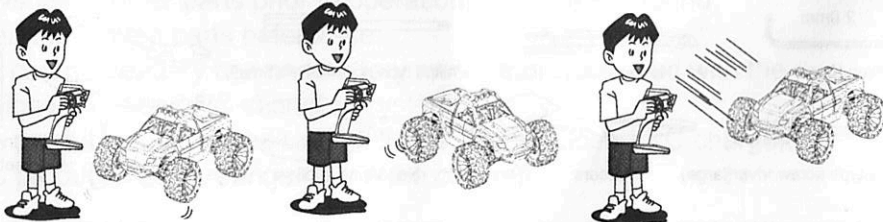
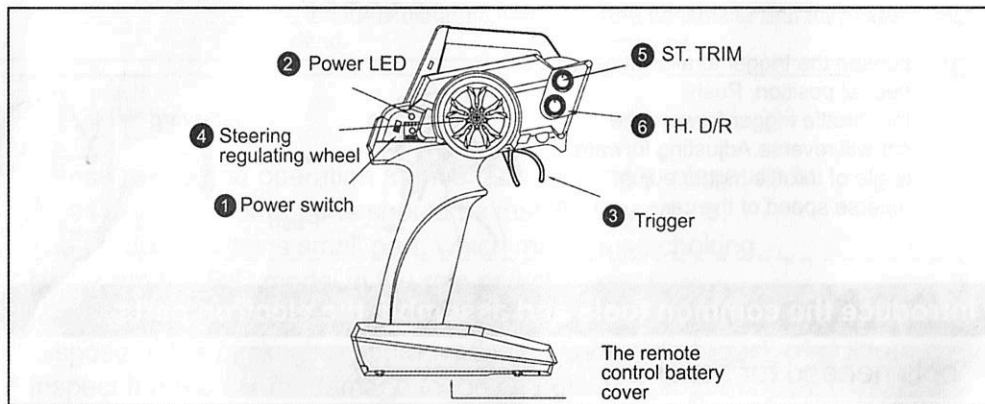

### Practice

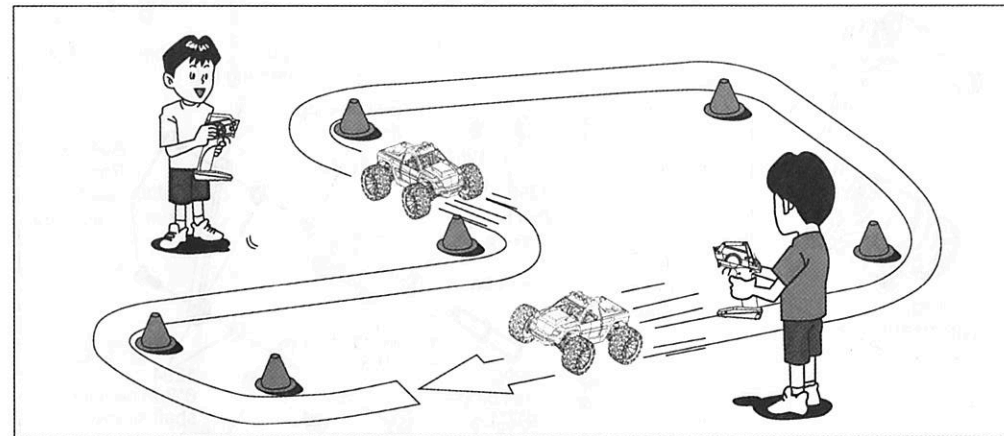

Let's practice! Make an R/C car circuit at a wide and safe location using corner pylons (available separately), empty cans or such. Drive fast on straight section and slow down for curved sections.

### Maintain

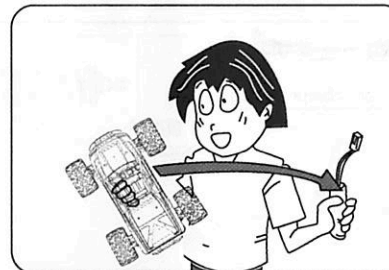

When the car is not in use, you should remove the battery from the car.



Completely remove sand, mud, dirt etc.

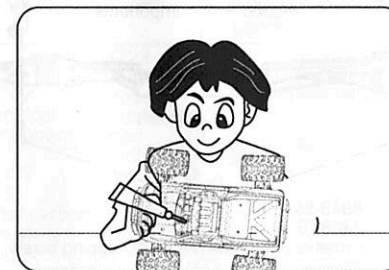

Apply the rust prevention oil to metal parts.

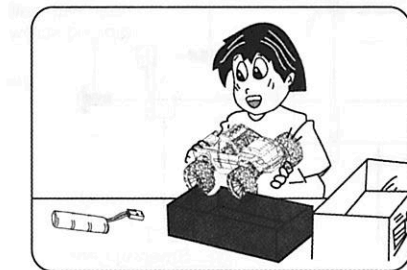

Store the car and batteries separately when not in use.





1992 right tire

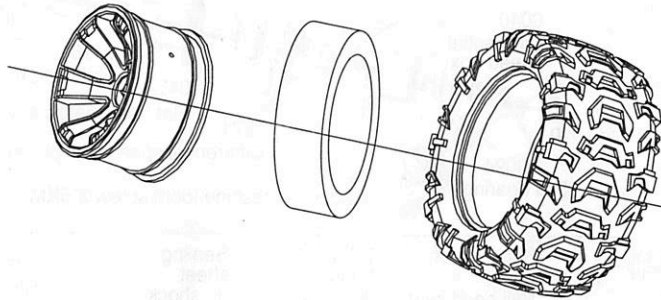

8



1992 left tire

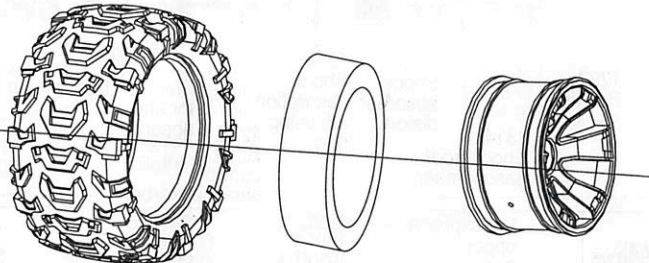

9

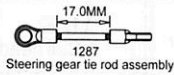

1287 Steering gear pull ball head seat

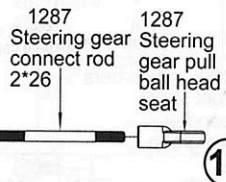

1287 Steering gear pull ball head seat

10

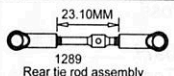

1289 Rear tie rod assembly

Long rod 4.5\*40

11



The ball head block

The ball head block

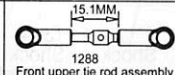

1288 Front upper tie rod assembly

Short rod 4.5\*36

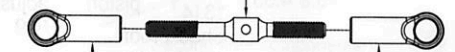

The ball head block

The ball head block

12

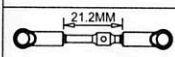

1289 Steering tie rod assembly

Short rod 4.5\*40

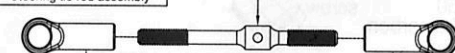

The ball head block

The ball head block

13

8

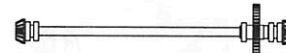

Central drive shaft assembly

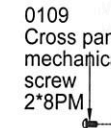

0109 Cross pan head mechanical screw 2\*8PM

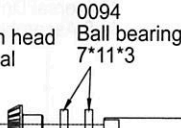

0094 Ball bearing 7\*11\*3

Central drive shaft



0094 Ball bearing 7\*11\*3



0109 Cross pan head mechanical screw 2\*8PM



1154 12T Active tooth

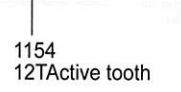

1260 Reduction gear

1260 Reduction gear

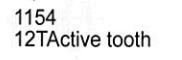

1154 12T Active tooth

14



Left rear wheel seat assembly

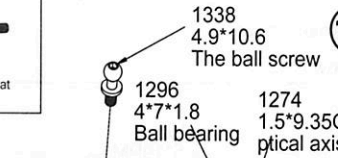

1338 4.9\*10.6 The ball screw

1296 4\*7\*1.8 Ball bearing

1274 1.5\*9.350 optical axis

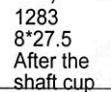

1283 8\*27.5 After the shaft cup

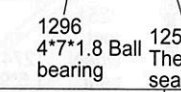

1296 4\*7\*1.8 Ball bearing

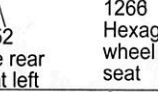

1252 The rear seat left

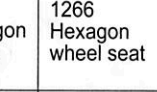

1266 Hexagon wheel seat

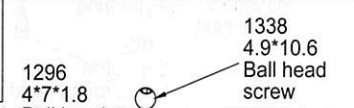

1338 4.9\*10.6 Ball head screw

1283 8\*27.5 The rear wheel shaft cup

16



Rear shock absorber assembly



Front shock absorber assembly

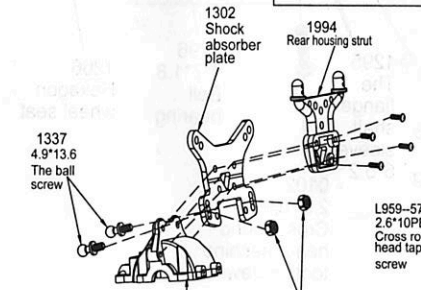

1302 Shock absorber plate

1994 Rear housing strut

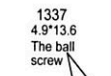

1337 4.9\*13.6 The ball screw



1254 Top cover of rear wave box



A949-49 M3 nut

L959-57 2.6\*10PB Cross round head tapping screw

17

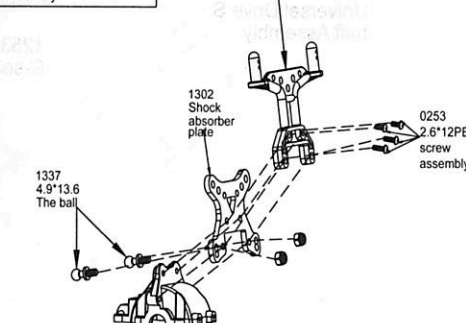

1994 Front shell strut

1302 Shock absorber plate

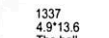

1337 4.9\*13.6 The ball

1254 Front box top cover

18

9

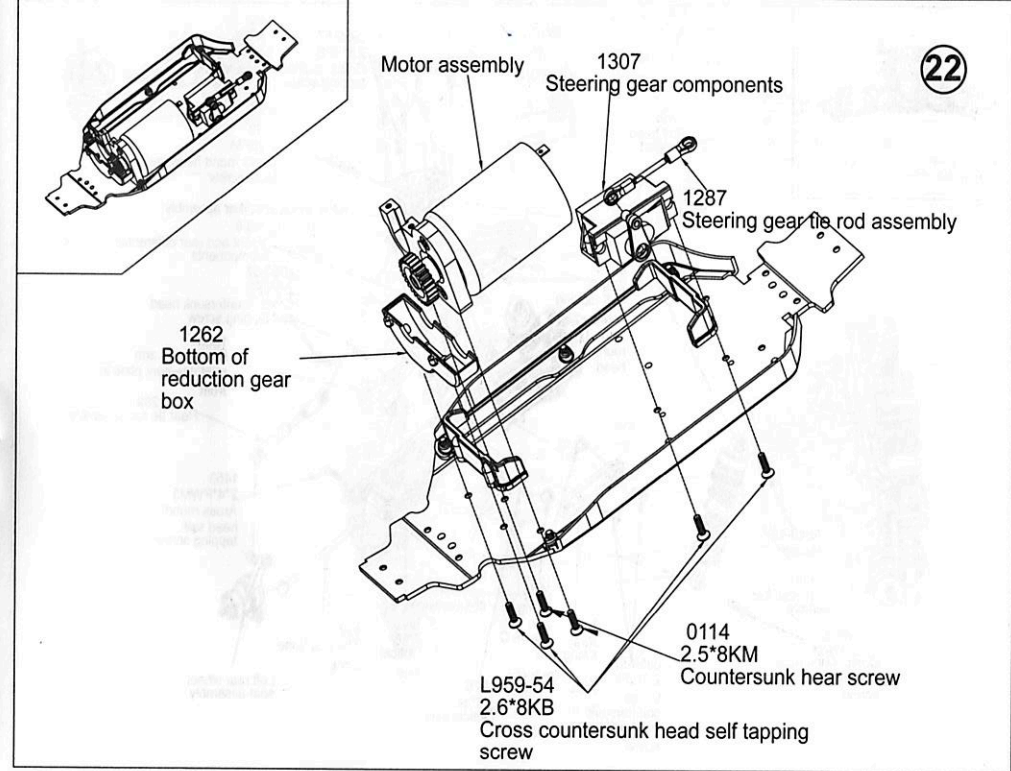
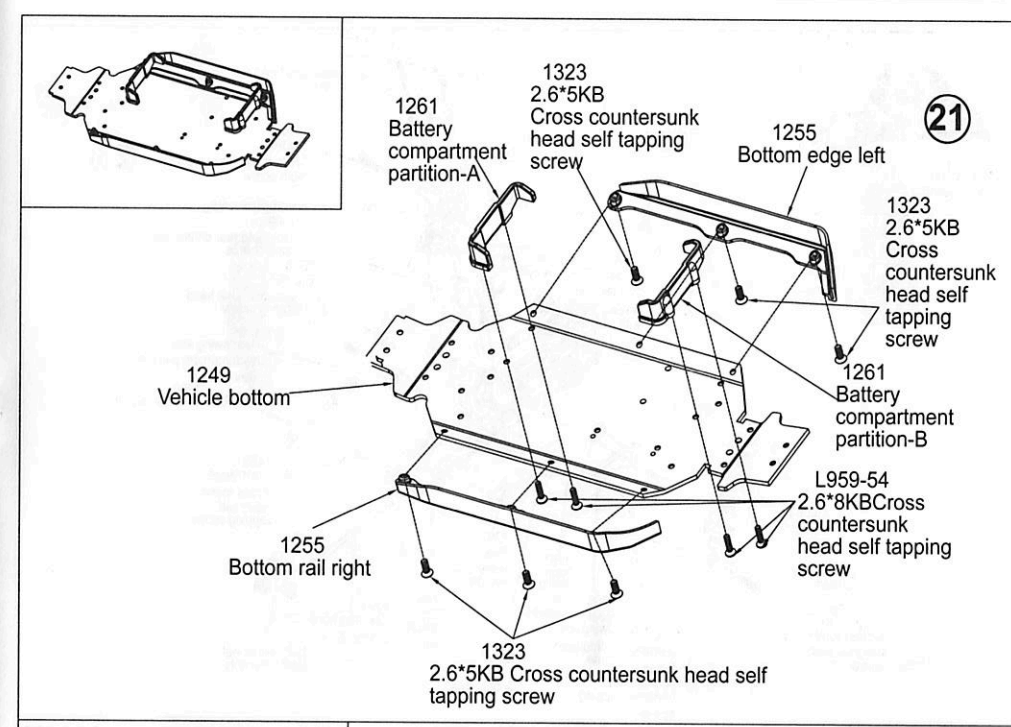
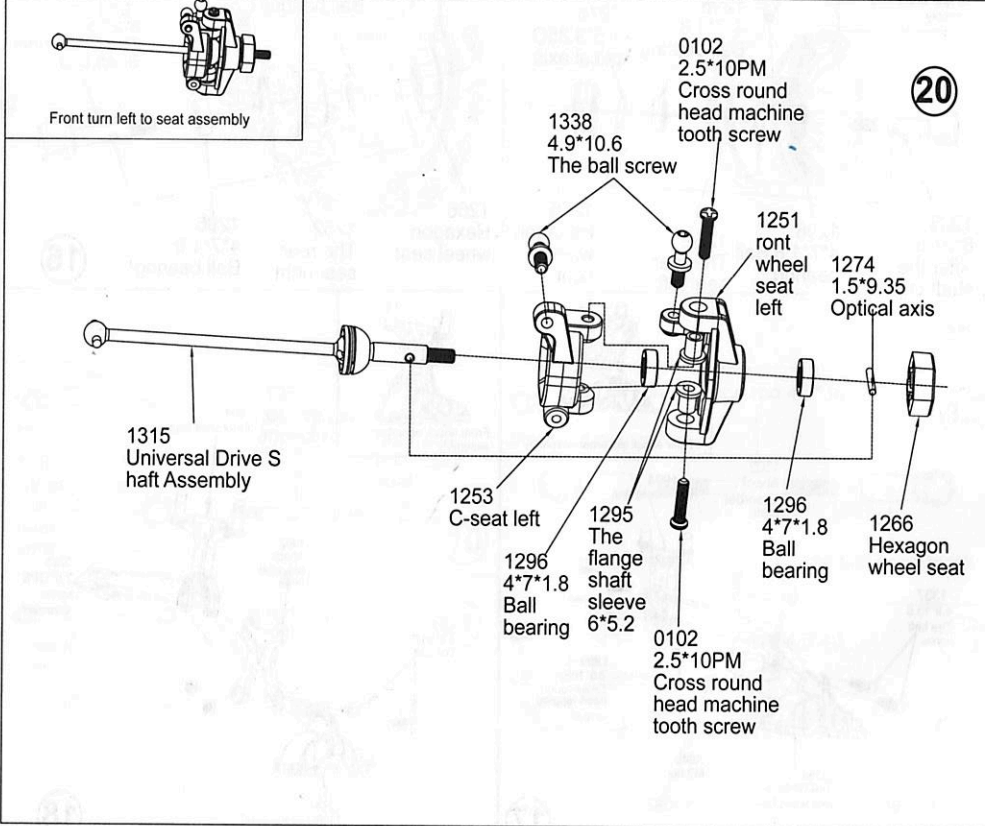
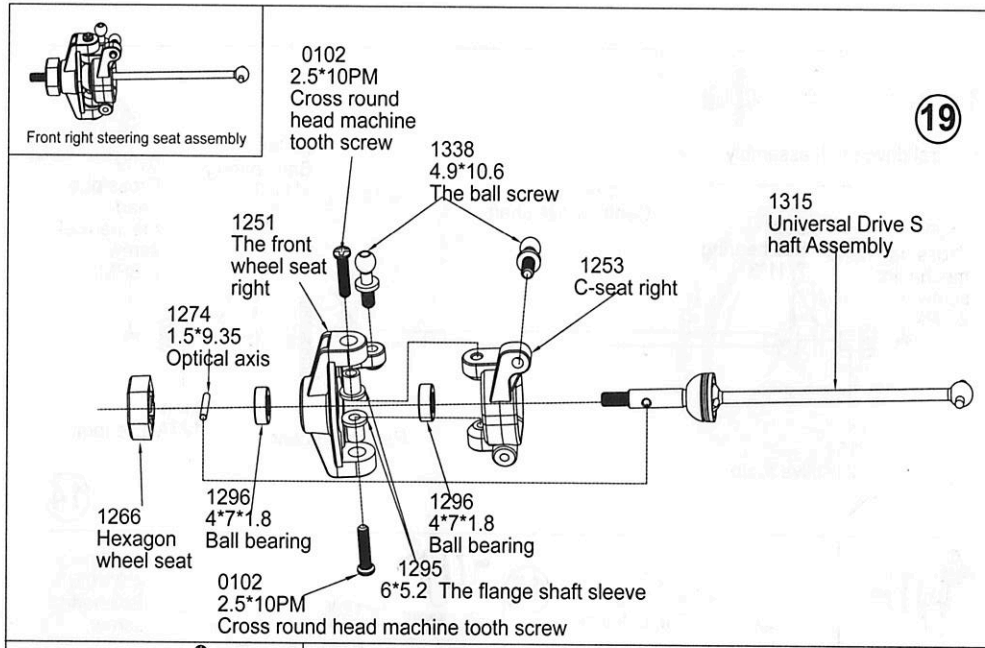



Rear wave box assembly

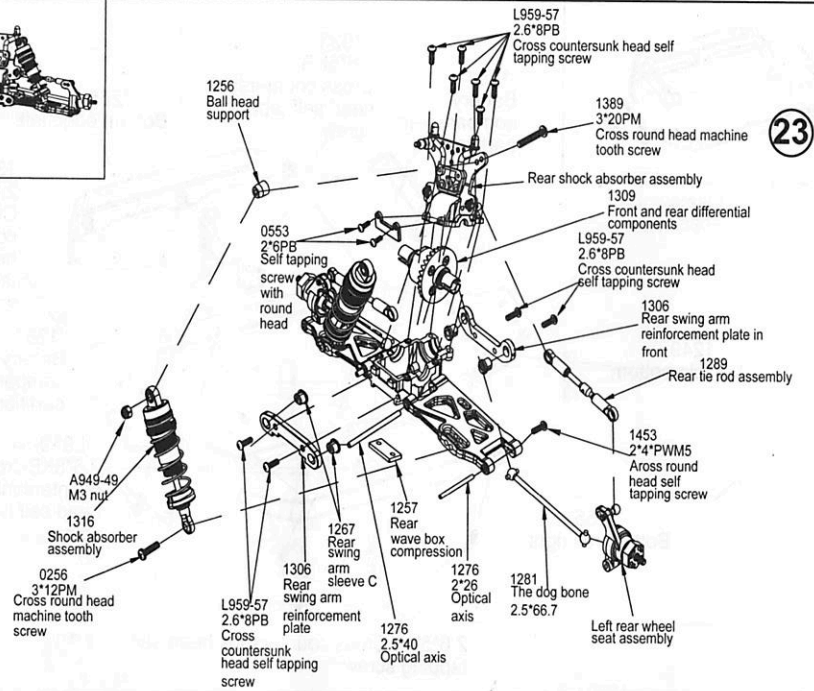

Front wave box assembly

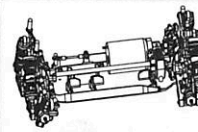
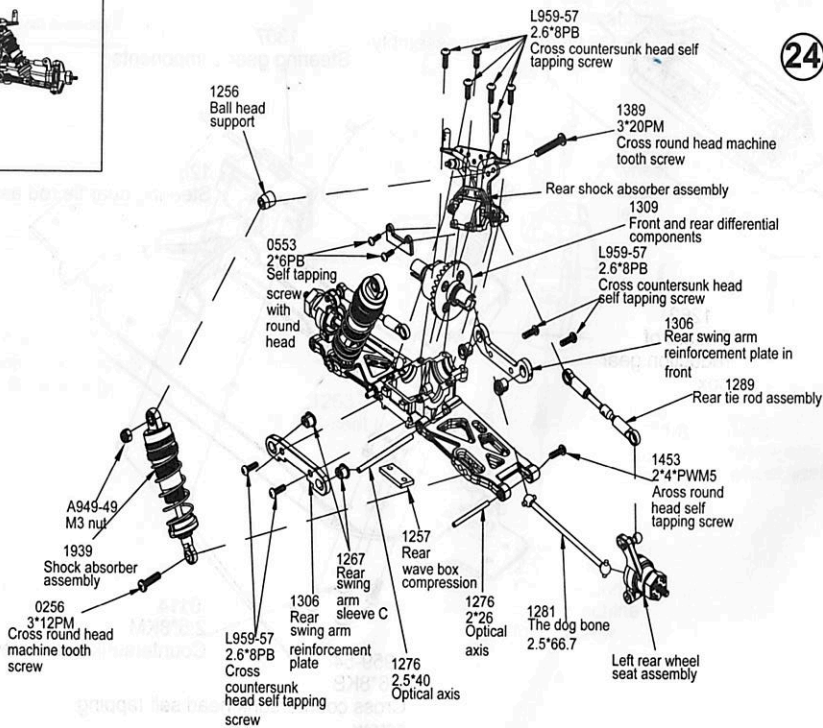

1262 Reduction gear cover

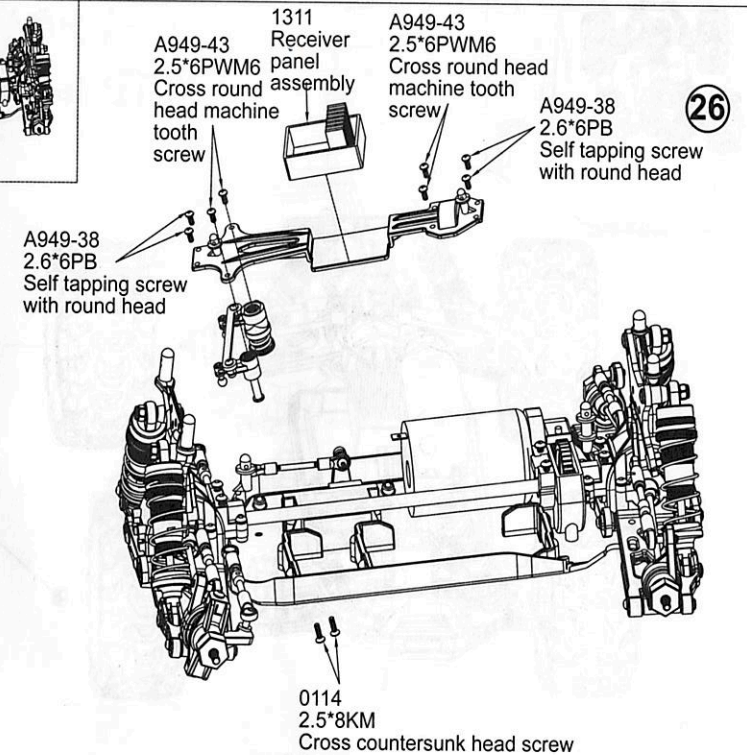
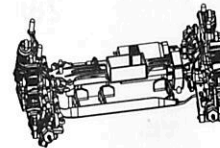
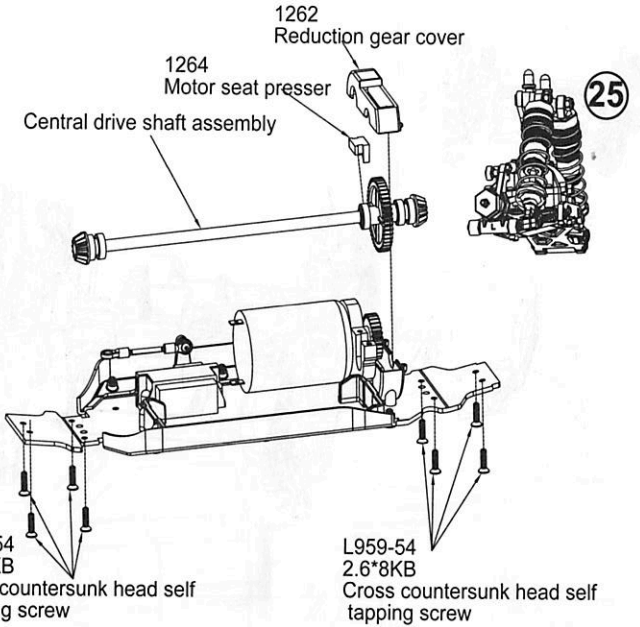



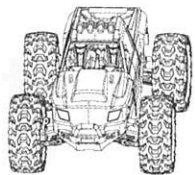

30

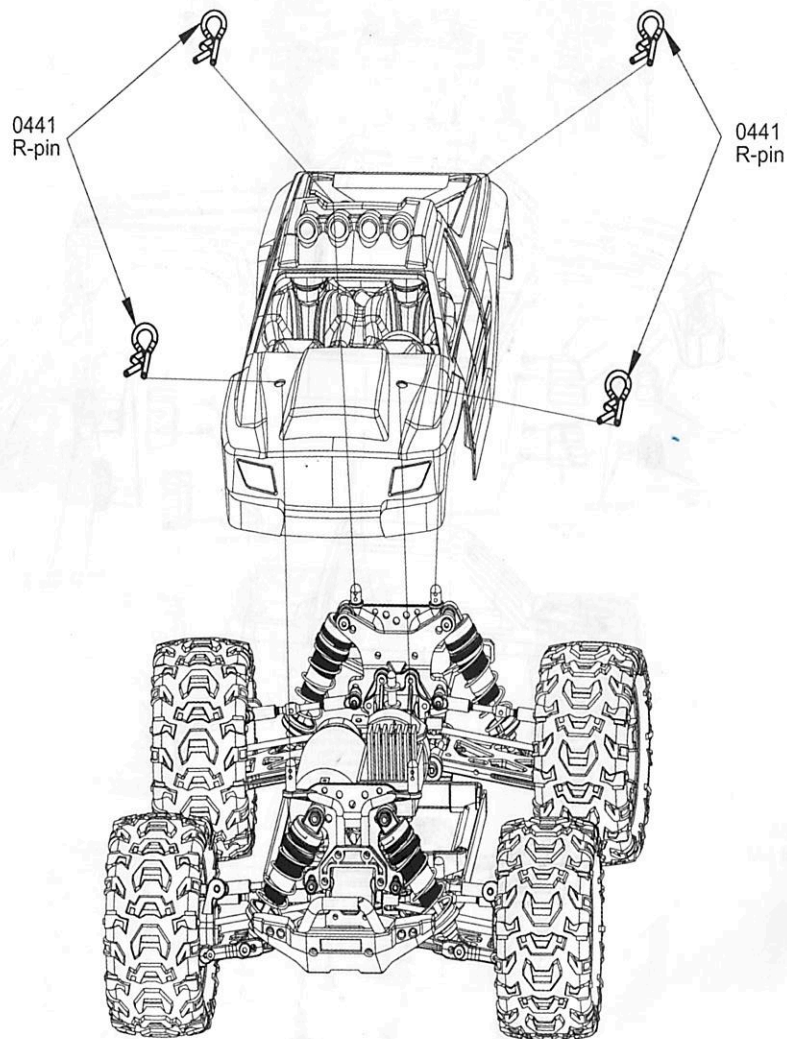

# Sale parts view

<p>0066</p>	<p>0073</p>	<p>0098</p>	<p>0102</p>
<p>12*5.2*0.2 Stainless steel gasket</p>	<p>Planet gear axis</p>	<p>M3*3 Include screw</p>	<p>2.5*10PM Cross round head screw</p>
<p>0114</p>	<p>0117</p>	<p>1374</p>	<p>0256</p>
<p>2.5*8KM Cross countersunk head screw</p>	<p>3*8KM Cross countersunk head screw</p>	<p>USB Charger</p>	<p>3*12PM Cross round head screw</p>
<p>1669</p>	<p>0422</p>	<p>0553</p>	<p>0582</p>
<p>V2-144001 Remote controller</p>	<p>2*6KM Cross countersunk head screw</p>	<p>2*6PB self tapping screw with round head</p>	<p>ST2*7PB screw assembly</p>
<p>1153</p>	<p>1154</p>	<p>1155</p>	<p>1249</p>
<p>30T Differential largeTeeth(Hardware)</p>	<p>12T ActiveTeeth (Hardware) Grou</p>	<p>24t differential gear (hardware) group</p>	<p>Chassis Plate</p>
<p>1250</p>	<p>1251</p>	<p>1252</p>	<p>1253</p>
<p>Front and rear arms</p>	<p>Front seat assembly</p>	<p>Rear seat assembly</p>	<p>C-seat assembly</p>

## Sale parts view

## Sale parts view



1254  
Wave box upper and lower cover group

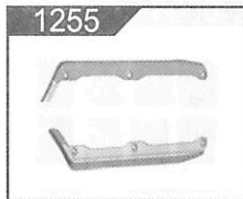

1255  
Left and right sides

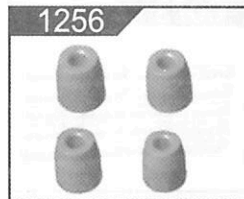

1256  
Support piece as-ball head

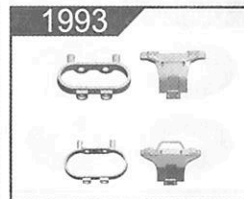

1993  
Front and rear anti-collision groups



1258  
Tail firmware Wing group



1259  
Two floor group

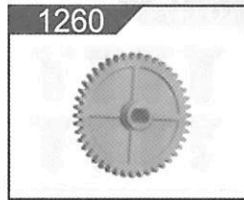

1260  
Gear reducer gear

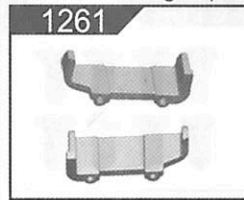

1261  
Battery holder



1262  
Reduction gearbox



1263  
Rocker arm of steering gear

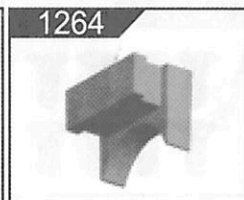

1264  
Motor seat pressure piece

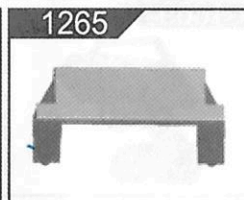

1265  
Steering gear base



1266  
hub drive hex

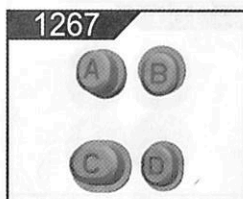

1267  
Front and rear swing arm shaft sleeve



1268  
Steering clutch group

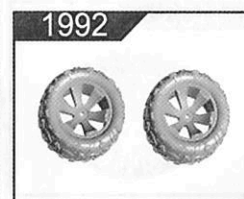

1992  
The left tire group



1998  
The right tire group

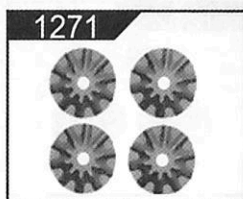

1271  
10T Differential Astero Teeth (Hardware) Group

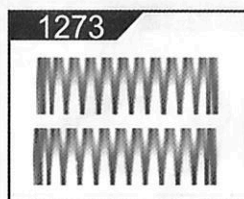

1273  
Shock absorber spring



1274  
1.5\*9.35 universal shaft group

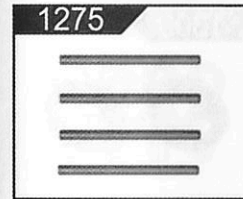

1275  
1\*9 Optic axis

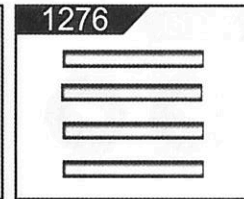

1276  
2 .5\*40 Optical axis

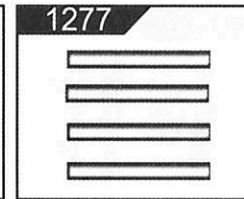

1277  
2 \* 26 Optical axis

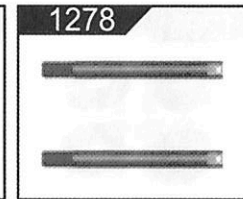

1278  
Shock absorber shaft component

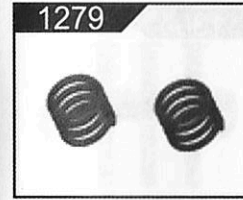

1279  
Buffer spring assembly

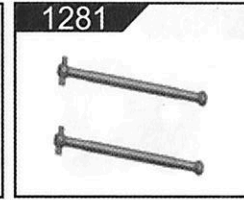

1281  
Dog bone assembly

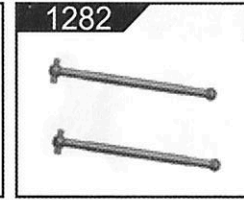

1282  
universal shaft assembly

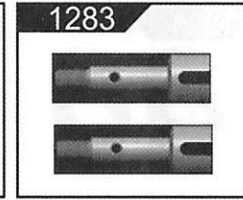

1283  
Rear Wheel CupComponent

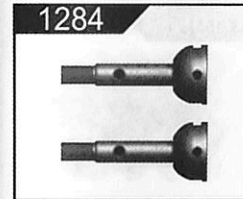

1284  
Front Wheel axisComponent

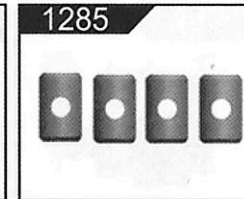

1285  
Cross shaft assembly

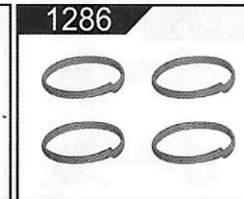

1286  
Universal cup springassembly

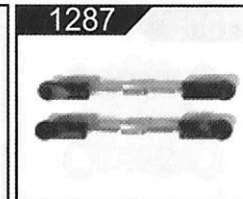

1287  
Steering gear leverassembly

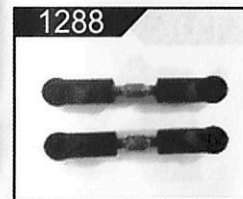

1288  
Short pull bar assembly

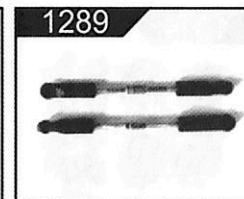

1289  
Long pull bar assembly

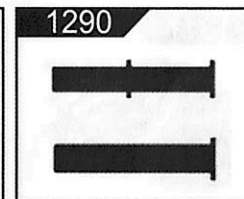

1290  
Steering column assembly



1291  
Steering column sleeve component

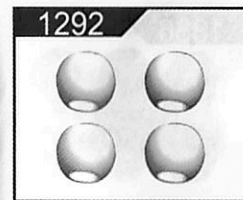

1292  
Ball head group

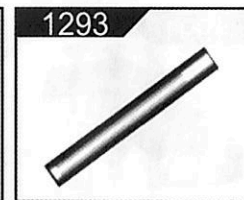

1293  
Central TransmissionAxis Component

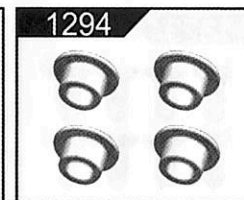

1294  
6\*2.7 Flange axis sleeve

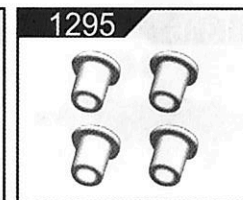













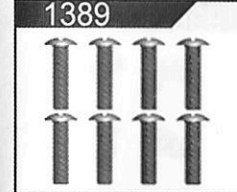
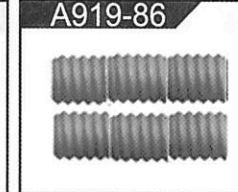



1295  
6\*5.2 Flange axis sleeve

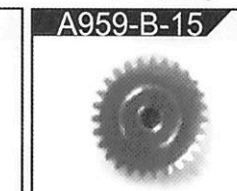



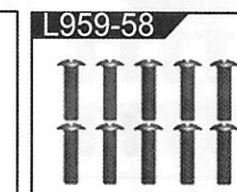
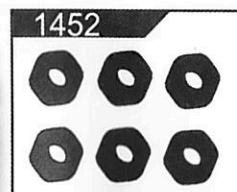
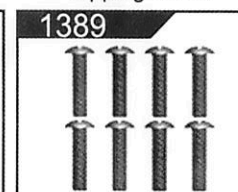

## Sale parts view

 <p>4*7*1.8 Ball bearing set</p>	 <p>1298 Cylinder as-shock absorber</p>	 <p>1299 Shockproof hat group</p>	 <p>1300 Adjusting ring group</p>
 <p>1301 Spring seat</p>	 <p>1302 Shock absorber plate group</p>	 <p>1303 Motor seat</p>	 <p>1304 Steering linkage</p>
 <p>1305 Front swing arm reinforcement</p>	 <p>1306 Rear swing arm reinforcement</p>	 <p>1307 Steering gear</p>	 <p>1951 Motor</p>
 <p>1309 Differential</p>	 <p>1311 Receiving board assembly</p>	 <p>1314 O-ring as-shock</p>	 <p>1315 Universal drive shaft</p>
 <p>1316 Shock absorber</p>	 <p>1323 2.6*5KB Countersunk head tapping screw</p>	 <p>1991 Car shell components</p>	 <p>1336 Heat sink</p>

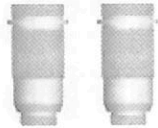
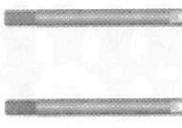
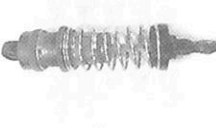
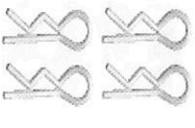
## Sale parts view

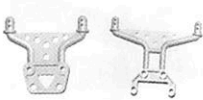
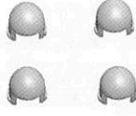
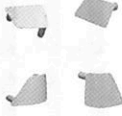
 <p>1337 4.9*13.6 Ball head screw set</p>	 <p>1338 4.9*10.6 Ball head screw set</p>	 <p>A202-04 4.0*9.5 Ball head screw set</p>	 <p>A202-15 2*8KB Cross countersunk head screw set</p>
 <p>1389 3*20PM Cross round head machine tooth</p>	 <p>A919-86 Machine screw set</p>	 <p>A949-22 Velcro</p>	 <p>A949-35 7*11*3 Ball bearing</p>
 <p>A949-38 2.6*6PB Round head self tapping screw</p>	 <p>A949-43 M2.5*6*6 Round head belt screw</p>	 <p>A949-49 M3 Nut</p>	 <p>A959-B-15 Motor gear</p>
 <p>A959-B-23 Battery</p>	 <p>L959-54 2.6*8KB Countersunk head tapping screw</p>	 <p>L959-57 2.6*8PB Round head self tapping screw</p>	 <p>L959-58 ST2.6*10 PB screwassembly</p>
 <p>1452 M3 flange nut</p>	 <p>1389 3 * 20pm Cross round head machine screw</p>	 <p>1453 2*4PWM5 Cross round head machine screw</p>	 <p>1656 2.5*8PWM6 Cross round head machine screw</p>

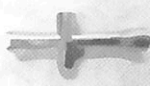
# Sale parts view

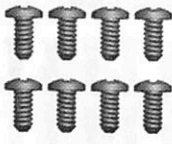
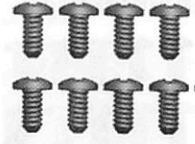
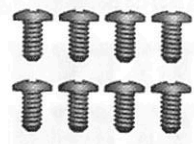
<p>1935</p> 	<p>1936</p> 	<p>1939</p> 	<p>0441</p> 
<p>Front shock block group</p>	<p>Front shock absorber axis group</p>	<p>Front shock mount</p>	<p>1.0*18 R Type Pin</p>
<p>1280</p> 	<p>1994</p> 	<p>1995</p> 	<p>1996</p> 
<p>Cup as-differential</p>	<p>Shell support group</p>	<p>Roof lampshade group</p>	<p>Front and rear lampshade group</p>
<p>1997</p> 	<p>1989</p> 	<p>1990</p> 	<p>1811</p> 
<p>Roof light frame group</p>	<p>Zinc alloy cross sleeve set</p>	<p>1.7 * 6 PWB5 screw group</p>	<p>2.3*6PWB6 Cross head with medium screw</p>
<p>0253</p> 	<p>1974</p> 	<p>1999</p> 	
<p>2.6*12PB Cross round head tapping screw</p>	<p>2.3*4PWB8 Cross head with medium screw</p>	<p>2.6*10KB Countersunk head tapping screw</p>	