



NO.: EX86120  
USER MANUAL  
**OFF-ROAD CRAWLER**



**ROCK CRAWLER**



**DESERT  
FOX  
4X4**



Please read and follow all the instructions in the manual before use.



## PRODUCT QUALIFICATION CERTIFICATION

**The product has conducted IQC (Input Quality Control) and full inspection before delivery. The manufacturer is responsible for quality assurance. Remote Control model is assembled manually, and then there may have some defects in the production process. Once the product is modified or incorrect operation, it cannot apply for replacement and return services, for the parts and accessories may be damaged. Please contact the retail seller for after-sales service when needed. The product conforms to technical requirements of export safety regulations.**

Factory Address: Huang Jiang Town, Dong Guan City, Guang Dong Province, China  
Website: [www.RGT-RACING.Com](http://www.RGT-RACING.Com)

Production Date: refer to packing instruction



## Introduction

We would like to welcome you to the world of remote control cars. What are RC cars? The simple answer is that they are radio controlled cars that respond precisely to your command. The more complete answer is that they can be a great addition to your lifestyle. RC car building and racing teach valuable mechanical and electrical skills, promote teamwork and encourage racers to test their skills with other racers from around the world. Whether you are just having fun racing your car in your backyard or racing at the world competition contest, radio controlled car racing is a great hobby.

We have been making RC products aimed at making our hobby fun and exciting with an affordable price. We are confident that your experience with our products will be positive. Of all the radio controlled models out there, no question about it, RC cars are the hardest to operate. This user manual covers a wide range of topics from nitro powered remote control cars to electrical powered remote control cars. We highly recommend that you read this user manual thoroughly and carefully before assembling and operating. Please follow all precautions and recommendations located within the manual. Be sure to retain the manual for future reference, routine maintenance, and tuning.

This product is not a toy. It is not recommended for children under 14 years old and any minor should be accompanied by an adult when operating. This product is a precision machine that requires proper assembly and setup to avoid accidents. Failure to take caution when operating this product may result in serious injury or property damage. It is the owner's responsibility to operate this product in a safe manner. Manufacturer and its distributors are not responsible in any way for any and all bodily injury(s) and/or property damage that may occur from the use of or caused by in any way or this product.

## Warnings

- The product is not intended for those under 14 years of age without proper adult supervision. The product is not a toy. It is a precision machine requiring proper assembly and setup to avoid accidents and it is the responsibility of the owner to operate this product in a safe manner as it can cause serious personal injury and damage to property due to carelessness or misuse.
- Do not attempt to disassemble or modify any of the product components without the assistance of an experienced RC user.
- Only use the correct type of battery to operate. Using any wrong type of battery will damage the product and possibly make it dangerous to operate.
- The motor(s) may get hot during use. Always allow 10-15 minutes between each operation for the motor to cool down. This will prolong the life of your product.
- Choose an appropriate operating site consisting of flat, smooth ground, and clear open field. Do not operate near buildings, high voltage cable lines, or trees to ensure safety operation. Operate in safe area only, away from other people. RC models are prone to accidents, failures, and crashes due to a variety of reasons including, lack of maintenance, user error, and radio interference. Users are responsible for their actions and damage or injury occurring during the operation.
- Do not operate in inclement weather, such as rain, wind, snow or darkness.
- The product is composed of precision electrical components. It is critical to keep the product away from moisture and other contaminants. Do not allow them to get wet. Electrical damage may occur that could affect safe operation.
- You should complete a successful pre-run check of your radio equipment and model prior to each run.
- Use replacement parts from the original manufacturer to ensure safe operation.
- Operate this product within your ability. Do not operate under tired condition.
- After each use, always allow the battery to cool down before recharging. When charging the battery pack, do not overcharge! If batteries get hot during charging, discontinue charging immediately and disconnect the battery from the charger. Never leave battery unattended while charging. If you are unsure of how to charge this battery, please seek the advice of experienced RC users. Never let children charge the battery without adult supervision.
- Always turn on the transmitter before connecting the battery on the model. When turning off the model, always disconnect the battery first, and then turn off the transmitter. If the order is reversed, the model may become uncontrollable and cause serious damage.
- If you are in doubt of your ability to operate the model, we strongly recommend that you seek assistance from experienced RC users or join your local modeling club to gain the required knowledge and skill. As the manufacturer and distributor, we assume no liability for the use of this product.
- Before turning on your model and transmitter, please check to make sure no one else is operating under the same frequency. Frequency interference can cause your model, or other's models to crash. The guidance provided by experienced RC users will be valuable for the assembly, tuning, trimming, and actual first flight.
- Never allow batteries to run low or you might lose control of the model.
- Plastic is very susceptible to damage or deformation due to extreme heat and cold climate. Do not store the model near any source of heat such as oven or heater. Store the model indoors, in a climate-controlled, room temperature environment.
- Never shorten the receiver antenna; or this might affect the transmitting range of the radio system.
- This product is a RC hobby model, do not use for other purpose.

## BOX CONTENTS

### The items inside the box:

- 1) Ready-to-run vehicle
- 2) Transmitter
- 3) Charger
- 4) Manual
- 5) RGT decal sheet



## OPERATION CHECKLIST

1. Read and follow all the instructions in the entire manual before operation
2. Familiar with all the features and parts of the product
3. Check if all screws and nuts are tight before operating
4. Check if the vehicle battery is fully charged, and install it in the vehicle
5. 4AA batteries needed for the transmitter
6. Power on the transmitter, and check the throttle and steering is normal
7. Check the radio system function
8. Maintenance the vehicle when needed

## CHARGE THE VEHICLE BATTERY

1. Connect charger plug with mains jack and then connect with connector of battery.
2. Please be care of safety while charging, please remove charger plug from the mains jack once finish charging. Will be over heat if it is too long to be charging or incorrect charging way. must stop charging if over 45 degree for the battery temperature.
3. Do not charge for battery at once when you take it away from your car. Please make sure battery in cool condition before recharge battery to keep battery performance running well and get a longer use life.

### BATTERY CHARGING SCHEMATIC

(the Red or Yellow light indicate charging. The Green light indicate full-charged. The charging needs 3 or 4 hours.)

\*The factory-fitted battery is NiMh battery  
\*The battery charger plug is equipped by the ordered region regulation.

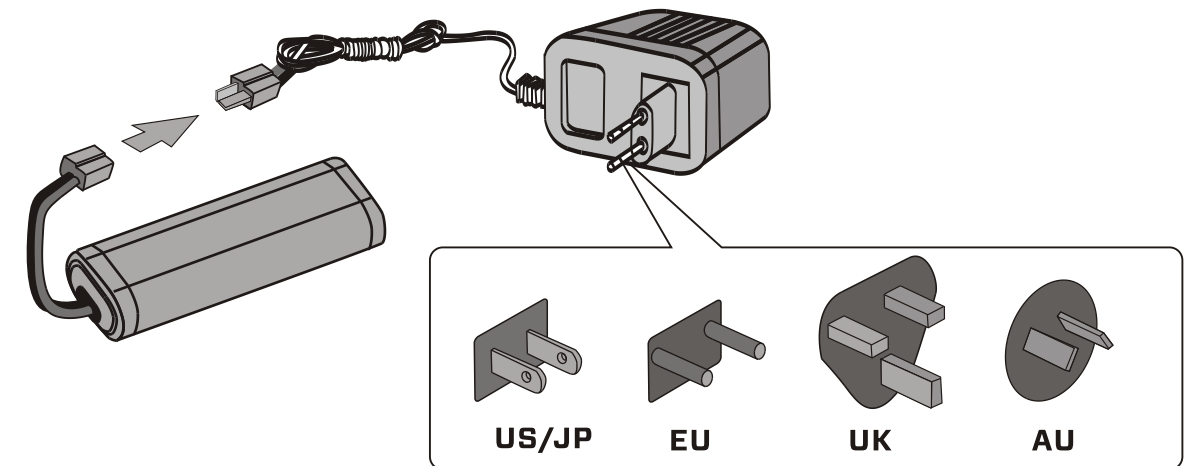

## Recommend Li-Po battery and Caution

This product can use the 2S or 3S Li-Po battery.

### WARNING:

Require exclusive charger when use Li-Po battery  
Require to set into Li-Po mode firstly  
before using Li-Po battery.

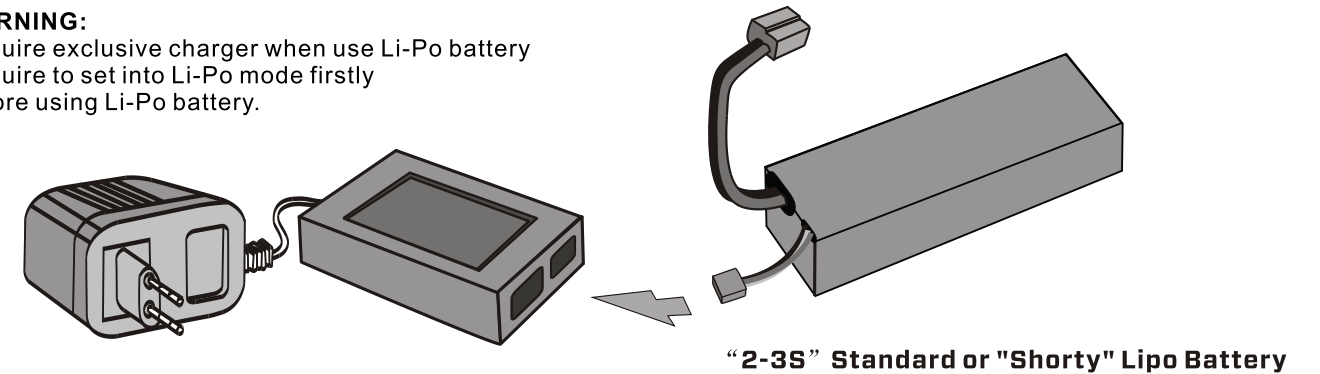

## Lithium Polymer (LiPo) Battery Warnings

- Never charge a lithium polymer battery with a charger designed for NiCd, NiMH, or any other type of battery chemistry. Use ONLY charger designed for LiPo battery.
- Do not leave LiPo battery unattended during charging.
- Do not overcharge the battery.
- Always place the battery on a heat resistant surface alone when charging.
- Always put the LiPo battery inside a charging protection container while charging.
- Do not allow LiPo cells to overheat at any time. Cells which reach greater than 140 Fahrenheit (60C) will usually become damaged and will catch fire.
- Do not charge LiPo cells on or near combustible materials including paper, plastic, carpets, vinyl, leather, and wood. inside an R/C model or full size automobile.
- Do not discharge LiPo; doing so will damage the battery.
- Do not expose LiPo cell to water or moisture at any time.
- Do not store battery near open flame or heater.
- Do not assemble LiPo cells or pre-assembled packs together with other LiPo cells or packs.
- Always store LiPo battery in a secure location away from children.
- Always remove the LiPo battery if model is involved in any kind of crash. Carefully inspect the battery and connectors for even the smallest damage. CAUTION: cells may be hot!
- Do not allow the electrolyte to get into eyes or on skin. Wash affected areas immediately if they come into contact with electrolyte. Do not alter or modify connectors or wires of a LiPo battery pack.
- Always inspect the condition of the battery before charging and operating.
- Do not short circuit the LiPo battery.
- Do not have contact with a leaky/damaged battery directly.
- Do not charge battery out of recommended temperature range (0C - 45C).

## NiMH Battery Instructions

- Never dispose of NiMH batteries in a fire or store near sources of heat.
- Only use the supplied NiMH charger to charge the NiMH battery. Using another charger may permanently damage the battery and surrounding components and may also lead to injury.
- Batteries should only be charged on a fireproof surface, away from any flammable materials.
- Never leave the battery unattended when charging or discharging.
- Batteries must be discharged or fully exhausted before being disposed of. Cover exposed poles with adhesive tape to prevent short-circuiting!
- Never disassemble or alter the battery contacts. Do not damage or puncture battery cells. Doing so would result in an explosion hazard!
- Keep the NiMH battery away from children.

## Shock Maintenance

After each day of running, you should check your shocks for adequate fluid. If the fluid is low, or it is getting dirty, you should change the fluid in the shocks. To achieve better performance, you may also want to change the shock fluid and/or the pistons.

## Setting The Gear Mesh

Gear mesh is the clearance between the pinion and spur in an electric car or clutch bell and spur in a nitro car. It has impact on the vehicles performance. If the gear mesh is not set properly you may also damage the clutch bell and spur or the pinion gear and spur gear as soon as the vehicle starts running.

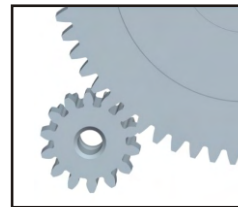

## Items for assembling or disassembling your model

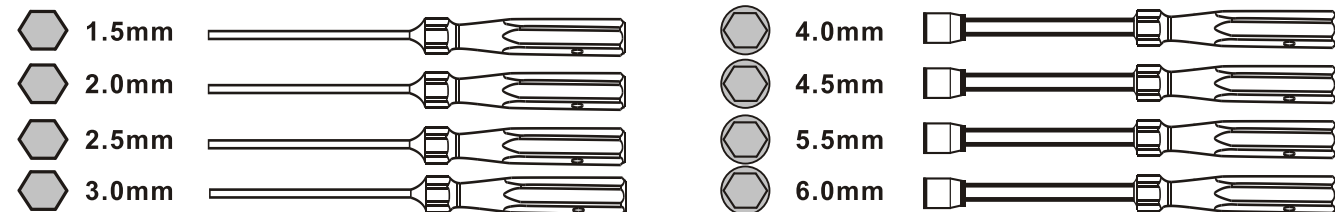

Hex. Screwdrivers

Socket Head Drivers

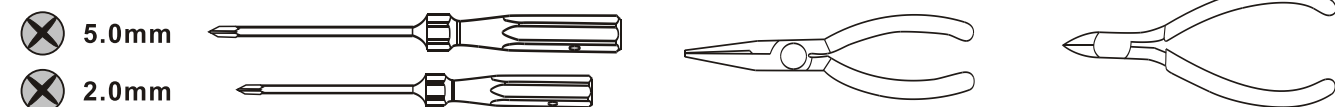

Philips Screwdriver

Curve Nose Pliers

Needle Nose Pliers

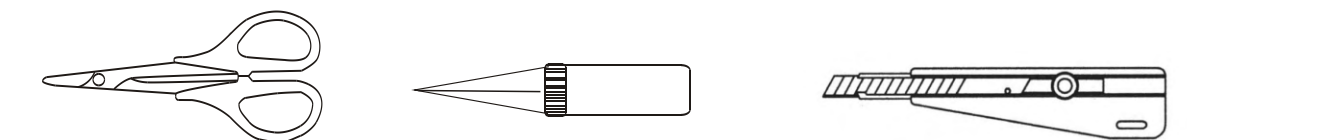

Lexan Scissors

Body Reamer

Hobby Knife

### WARNING!

Do not use a power screw driver to install screws into nylon or plastic materials. The fast locking may heat up the screws being installed that may break the molded parts or strip the threads during installation.

## Scheme Of Installation

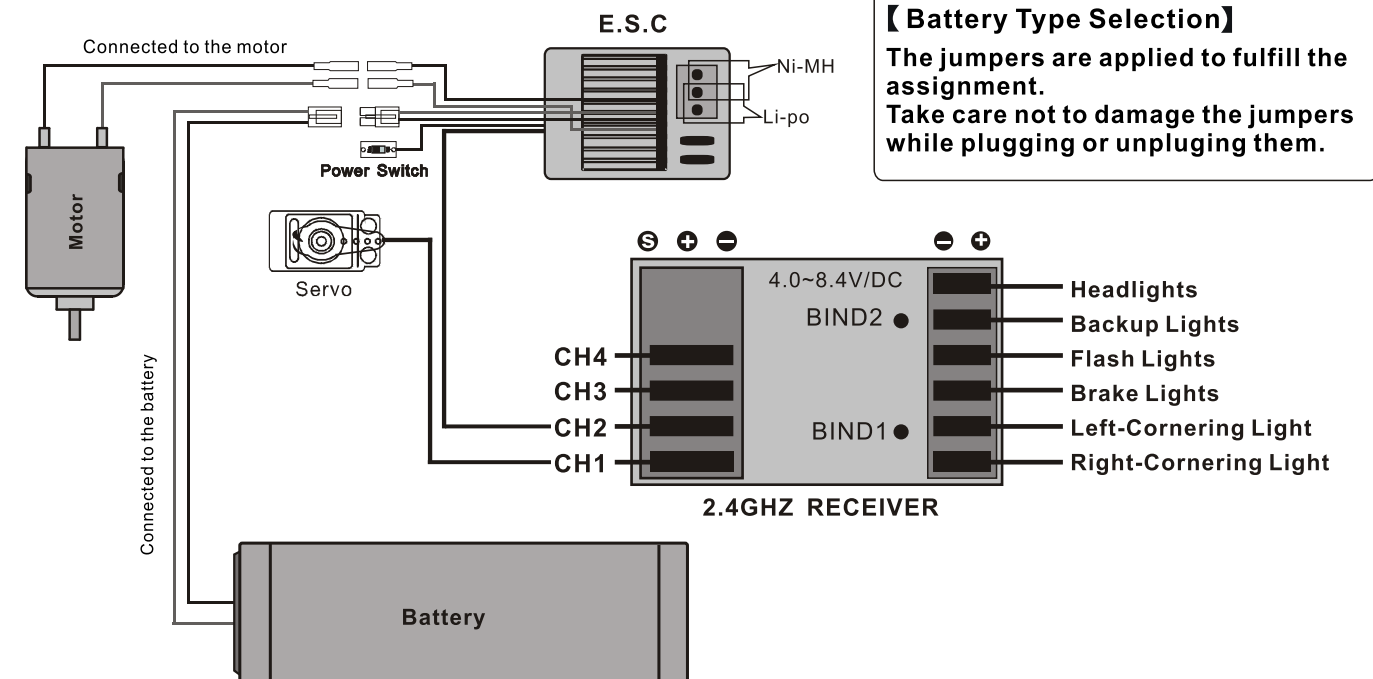

**【 Battery Type Selection 】**  
The jumpers are applied to fulfill the assignment. Take care not to damage the jumpers while plugging or unplugging them.

## 2.4GHZ Radio System

### Battery Installation:

1. Open the battery compartment cover.
2. Insert 4 AA fully charged batteries or 2S Li-Po batteries in correct polarity. (No response if battery polarity reversed.)
3. Close battery compartment cover.

### Install The Transmitter Batteries

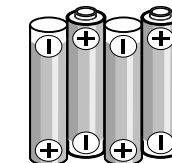

Batteries: 4 x 1.5 V "AA" (not included)

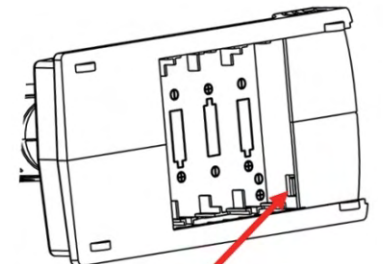

**! The battery socket is equipped with anti-reverse insertion function, wrong polarity connection will not burn the transmitter.**

### LED Light

1. Normal use: blue light flashes slowly.
2. Mixed direction for Tank mode: Red light is always on.
3. Low voltage warning: Yellow light flashes slowly.
4. Entering second menu level mode: Blue/Red light flashes quickly.

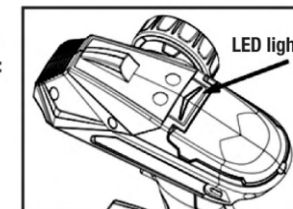

### Binding Process:

1. Press receiver button, LED indicator fast flashing means entering into binding mode, the receiver will automatically looking for the nearest transmitter signal.
2. The indicator will always ON after successful bond.

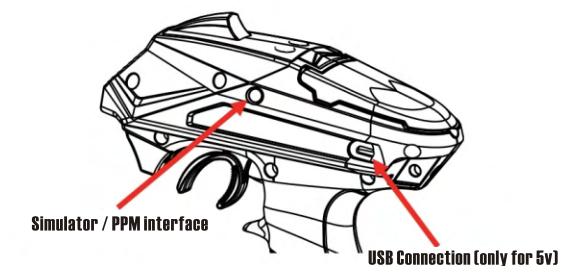
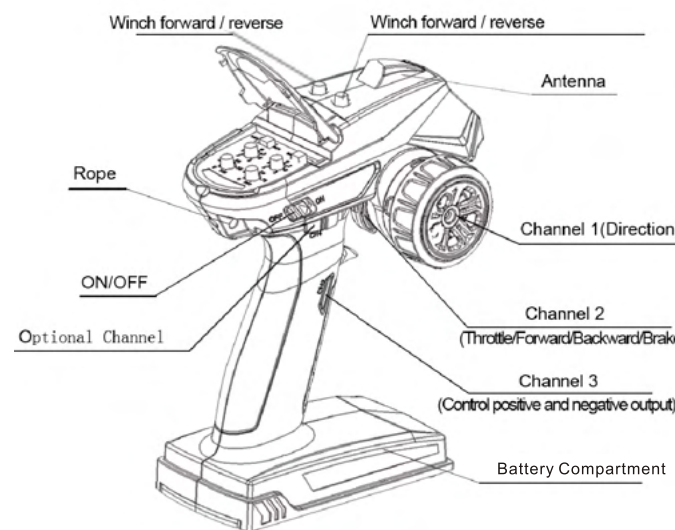

- CH1: Reverse for steering
- CH1: Sub-trim for steering
- CH1: EPA for steering
- CH2: Reverse for throttle
- CH2: Sub-trim for throttle
- CH2: EPA for throttle

### MENU SETTING:

To enter the program mode:

1. With the power off, move the steering wheel to its maximum forward position, hold this position and power on the transmitter.
2. The blue LED indicator will illuminate and remain solid, return the steering wheel to its neutral position, and press the CH3 button.

The LED indicator will now flash blue rapidly, indicating that you have entered program mode.

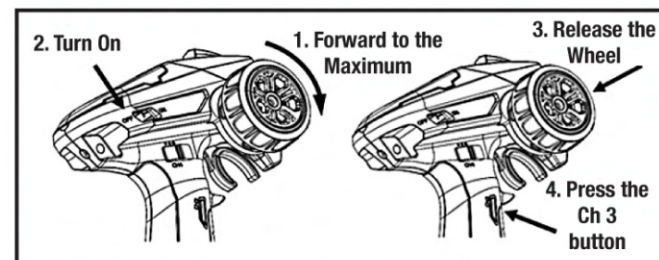

### PROGRAM THE TRANSMITTER:

Once in program mode, the travel end points of CH1 and CH2 can be configured:

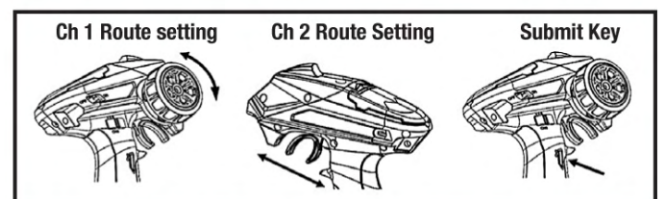

1. Rotate the steering wheel to its desired maximum position in both directions, returning it to its neutral position.
2. Pull/push the throttle trigger to its desired maximum position, forwards and backwards, returning it to its neutral position.
3. Once the steering wheel and throttle trigger have been in their neutral positions for 3 seconds, press the CH3 button once to save these settings.
4. The LED indicator will now flash steady blue, and the transmitter will operate normally. (Default factory settings are maximum travel for CH1 and CH2).

### IF CH3 AND CH4 REQUIRE PROGRAMMING:

When in program mode, CH1 and CH2 EPA dials on the control panel can be used to set the travel of CH3 and CH4 respectively.

Once in program mode:

1. Rotate the steering wheel to its desired maximum position in both directions, returning it to its neutral position.

2. Pull/push the throttle trigger to its desired maximum position, forwards and backwards, returning it to its neutral position.
3. Rotate and position the CH1 dial to configure the desired travel for CH3.
4. Rotate and position the CH2 dial to configure the desired travel for CH4.
5. Once all end points and travel settings have been adjusted, press the CH3 button to save these settings.
6. The LED indicator will now flash steady blue, and the transmitter will operate normally.

**Note: Each time program mode is initiated, all settings are erased and must be reconfigured.**

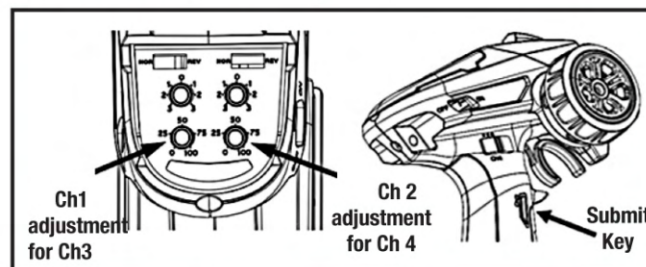

### MODE SWITCH:

To switch from 'Normal Mode' to 'Mixed Mode':

1. Push the throttle trigger to the maximum forward position and power on the transmitter. The LED indicator will rapidly flash blue.
2. Pull the trigger backwards to its maximum position, and release back to its neutral position. The LED indicator will now flash steady red/yellow to indicate that 'Mixed Mode' is enabled. To return to normal mode, repeat the above process ^. The LED indicator will flash steady blue to indicate that 'Normal Mode' is enabled.

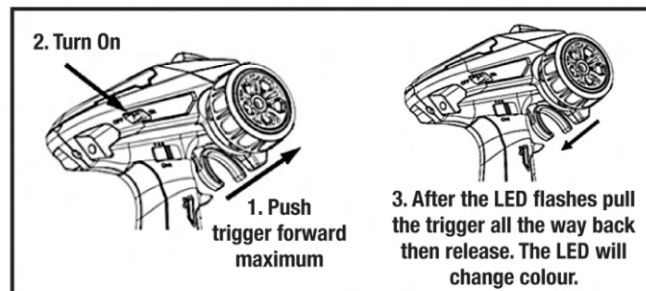

### MIXED MODE (RC TANK OPERATION):

Mixed mode will allow the connection of two ESC and motor combinations, to channel 1 and channel 2 of the receiver. With mixed mode is enabled, when the throttle trigger (CH2) is pulled backwards or pushed forwards, this will control the forward or backward movement of the model. Each connected motor will operate at a continuous

### Additional items needed for operation:



4 pcs AA Alkaline Batteries

### IMPORTANT!

Check that all screws and nuts are tight before each use.

## User Manual of Water-Proof Brushed Speed Controller

### WP-1060-BRUSHED

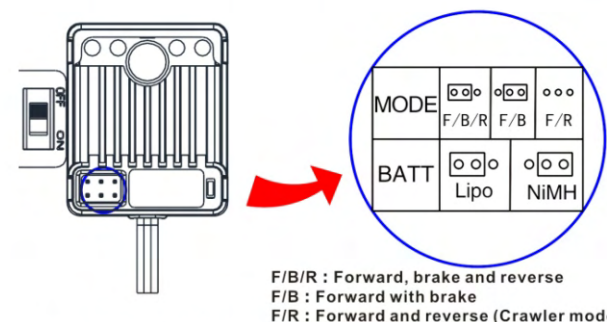

F/B/R : Forward, brake and reverse  
F/B : Forward with brake  
F/R : Forward and reverse (Crawler mode)

### FEATURES

- \* Water-proof and dust-proof for all weather races.
- \* Small size with built-in capacitor module.
- \* Automatic throttle range calibration, easy to use.
- \* Multiple protections: Low voltage cut-off protection for Lipo or NiMH battery / Over-heat protection / Throttle signal loss protection.
- \* Easily programmed with the jumpers.

### [SPECIFICATIONS]

Model	WP-1060-BRUSHED
Cont. / Burst Current	Forward: 60A / 360A Backward: 30A / 180A
Input	2-3S Lipo, 5-9 Cells NiMH
Cars Applicable	1:10 on-road, off-road 1:10 Crawler, Tank & Boat
Motor Limit	2S Lipo or 5-6 cells NiMH
	3S Lipo or 7-9 cells NiMH
Resistance	Fwd: 0.0008Ohm, Bwd : 0.0016Ohm
Built-in BEC	3A/6V (Switchmode BEC)
Dimension & Weight	36*30*18, 40g

**Attention: The incorrect polarity will damage the ESC immediately. If the motor runs in the opposite direction, please swap these two wire connections.**

### [PROTECTION FUNCTIONS]

1. Low voltage Cut-off (LVC) protection: If the voltage of battery pack is lower than the threshold for 2 seconds, the ESC will enter the protection mode. When the car stops, the red LED blinks to indicate the low voltage cut-off protection has been activated.

Table A: LVC protection for WP-1060-BRUSHED, (F/B/R or F/B mode).

2S Lipo	3S Lipo	4S Lipo	5-9 cells NiMH
Output reduces 50% at 6.5V Output cuts off at 6.0V, cannot be recovered	Output reduces 50% at 9.75V Output cuts off at 9.0V, cannot be recovered	Output reduces 50% at 13V Output cuts off at 12V, cannot be recovered	Output reduces 50% at 4.5V Output cuts off at 4.0V, cannot be recovered

2. Over-heat protection: When the internal temperature of the ESC is higher than 100 Celsius degree or 212 Fahrenheit degree for 5 seconds, the ESC will reduce and cut off the output power. When the car stops, the red LED blinks to indicate the over-heat protection has been activated. If the ESC cools down to 80 Celsius degree (176 Fahrenheit degree) the output power is recovered to normal state.
3. Throttle signal loss protection: The ESC will cut off the output power if the throttle signal has been lost for 0.1 second. The Fail Save function of the radio system is strongly recommended to be activated.

### [TROUBLE SHOOTING]

Trouble	Possible Reason	Solution
After power on, motor can't work, no sound is emitted, and LED is off.	The ESC doesn't get its working voltage; Connections between battery pack and ESC are broken. Switch is damaged.	Check the battery wires connection or replace the defective connectors. Replace the switch.
After power on, motor can't work; red LED blinks.	Throttle signal is abnormal. Automatic throttle range calibration is failed.	Check the throttle wire connection; make sure it is plugged into the throttle channel of the receiver. Set the TRIM of throttle channel to 0 or turn the knob to its neutral position.
The car runs backward while giving throttle. (The motor runs in the opposite direction)	The wire connections between ESC and the motor need to be changed.	Swap two wire connections between the ESC and the motor.
The car can't go backward.	The jumper position is wrong. The neutral point of throttle channel is changed or drifted.	Check the jumper and plug it to the correct position. Set the TRIM of throttle channel to 0 or turn the knob to its neutral position.
The car can't go forward, but can go backward.	The direction of throttle channel is not correct.	Reset the direction of throttle channel from original NOR to REV or from original REV to NOR.

Please review the ESC manual for more details.

# 1/10 SCALE READY-TO-RUN FJ DESERT FOX EX86120

## Specifications:

ITEM NO.	ITEM	TYPE	SCALE	DESCRIPTION	GIFT BOX SIZE	CERTIFICATION
Ex86120	Desert fox	Electronic Toy	1/10	Off-Road Crawler	57.5*27.5*28.2CM	EN71,RoHS,CE,FCC

LENGTH	WIDTH	HEIGHT	WHEEL BASE	DRIVE SYSTEM	DIAMETER OF WHEEL	WIDTH OF WHEEL	GEAR RATIO
550mm	245mm	252mm	313mm	4WD Shaft Drive	120mm	45mm	54:1

RADIO	E S C	MOTOR	SERVO	BATTERY PACK	WEIGHT	CHARGER SPEC	TRANSMITTER BATTERY
2.4GHZ	60A	RC550	15 KG	7.2v 2000mAh	3.05KG	9V500mAh (Euro/UK/USA)	Exclude

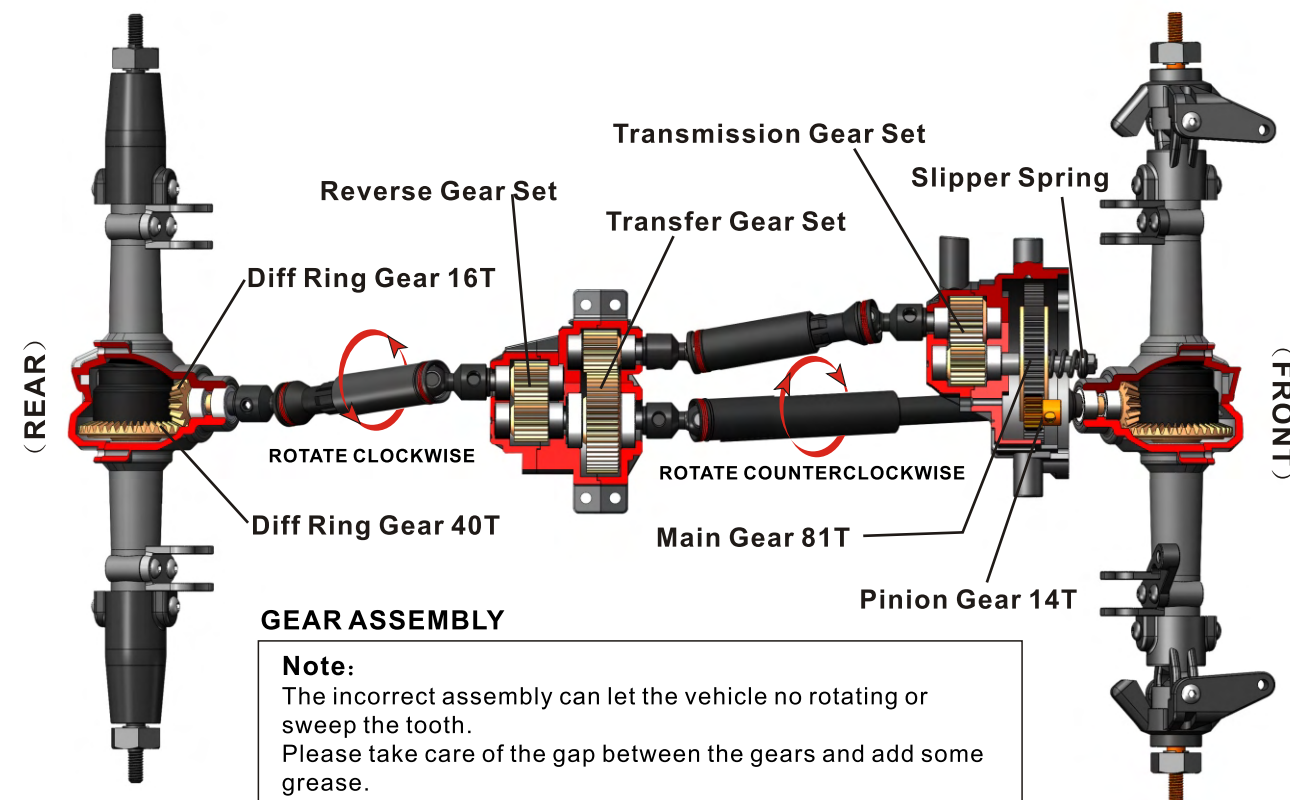
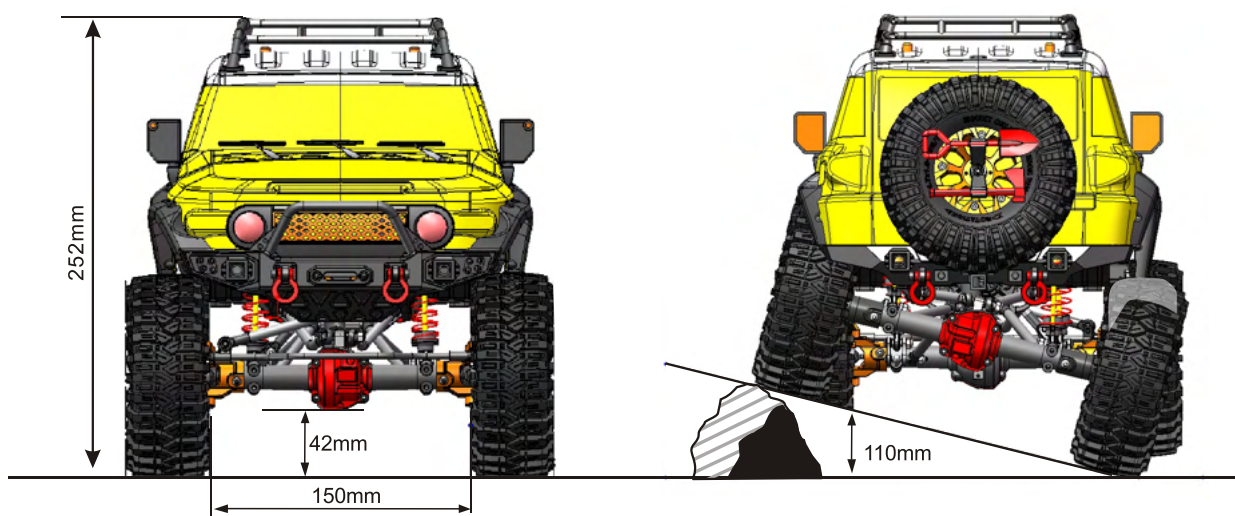

## VEHICLE PARTS

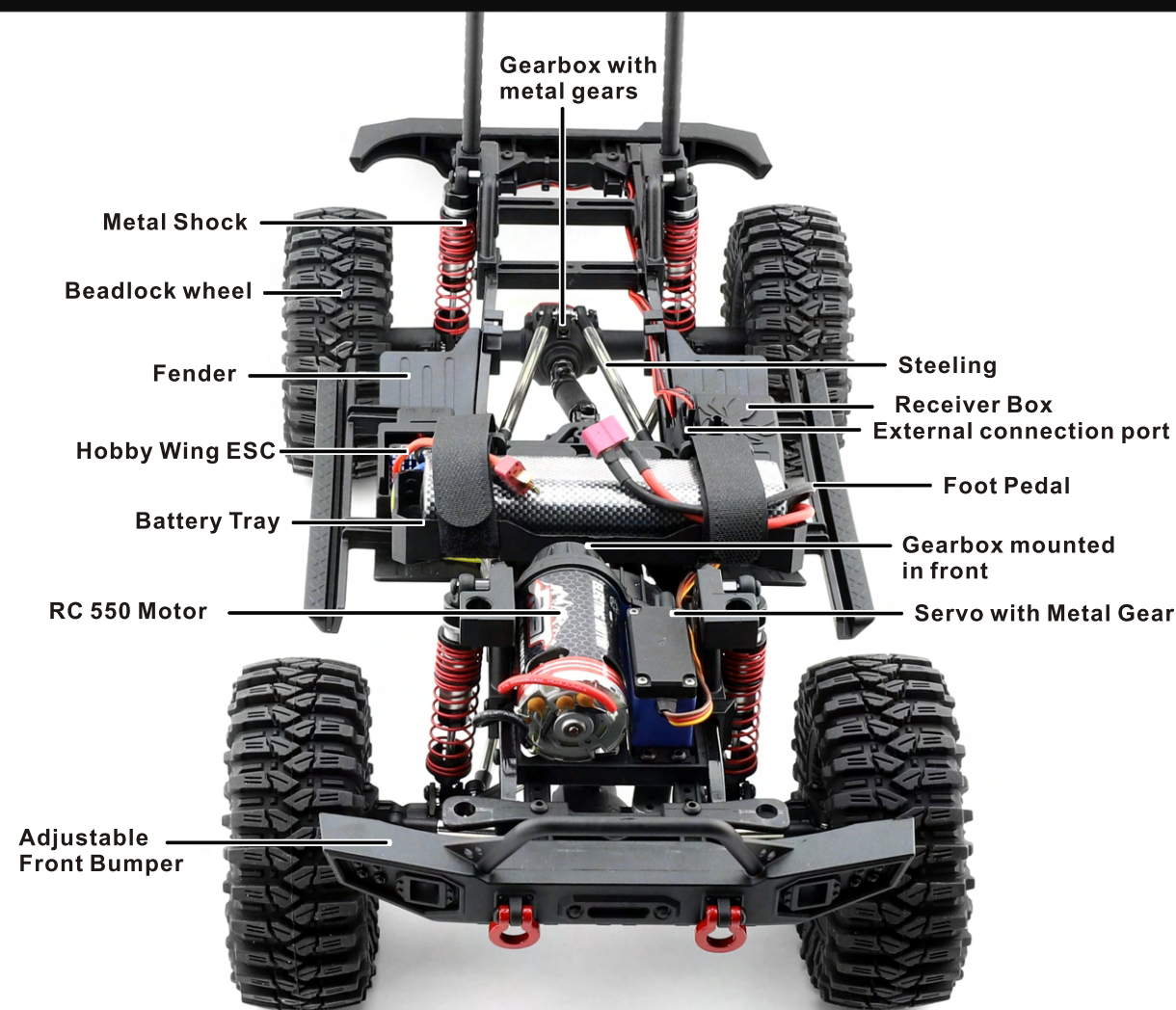





## REAR DRIVE SYSTEM ASSEMBLY

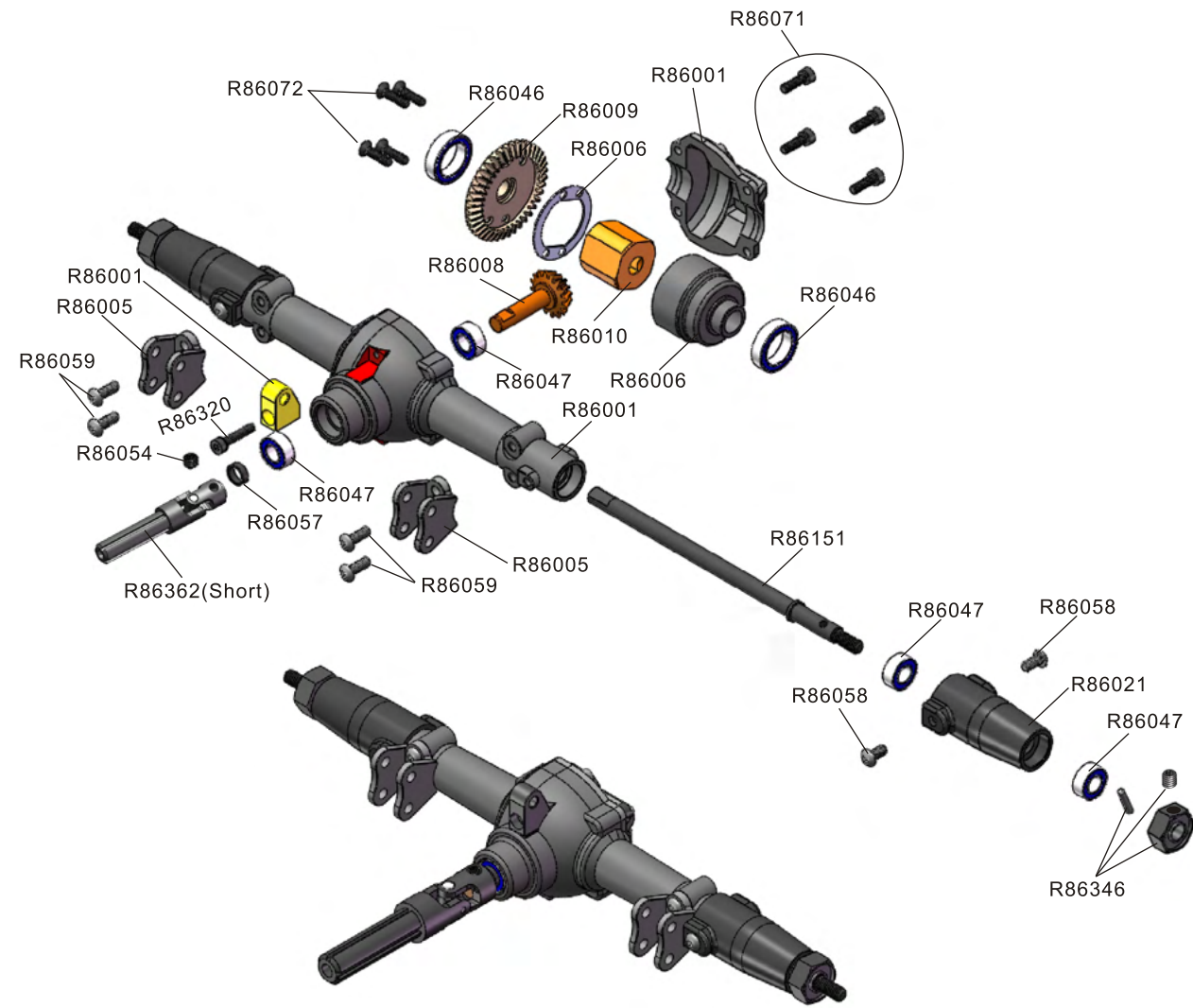

## READ SUSPENSION ASSEMBLY

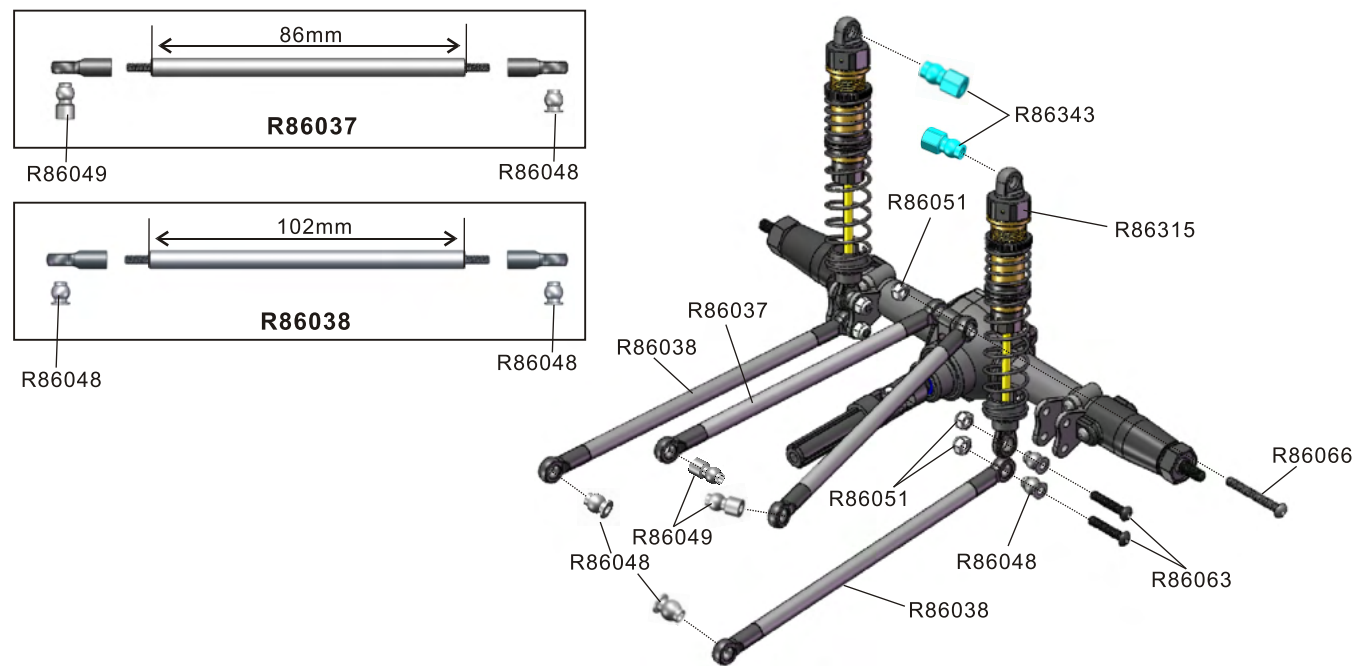

## CHASSIS RAIL ASSEMBLY

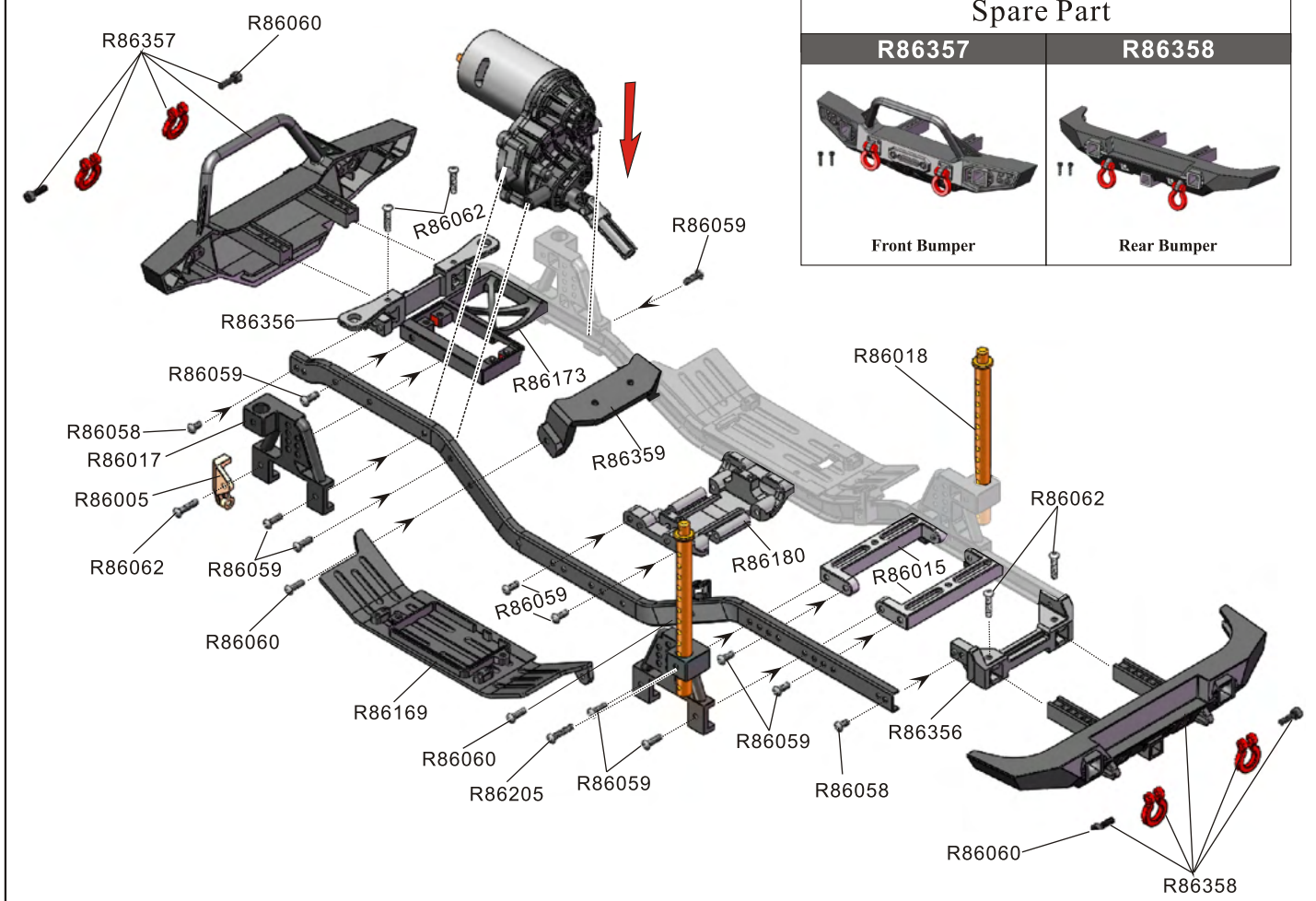

### Spare Part

R86357	R86358
Front Bumper	Rear Bumper

### Spare Part

 R86017 Body Plate	 R86356 Bumper Mounts/Foot Pedal	 R86169 Baffle (L/R)	 R86173 Servo Mount	 R86015 Battery/Caster Mounts
 R86180 Chassis Plate	 R86359 Battery Mount	 R86040 Chassis Rails	 R86005 Link Mount Set	 R86018 Body Post
 R86058 Button Head 3*6	 R86059 Button Head 3*8	 R86060 Button Head 3*10	 R86062 Button Head 3*14	 R86205 Button Head 3*15

### TRANSFER CASE / REAR SUSPENSION ASSEMBLY

**WARNING:**  
Install the driveshaft firstly, then do other step.

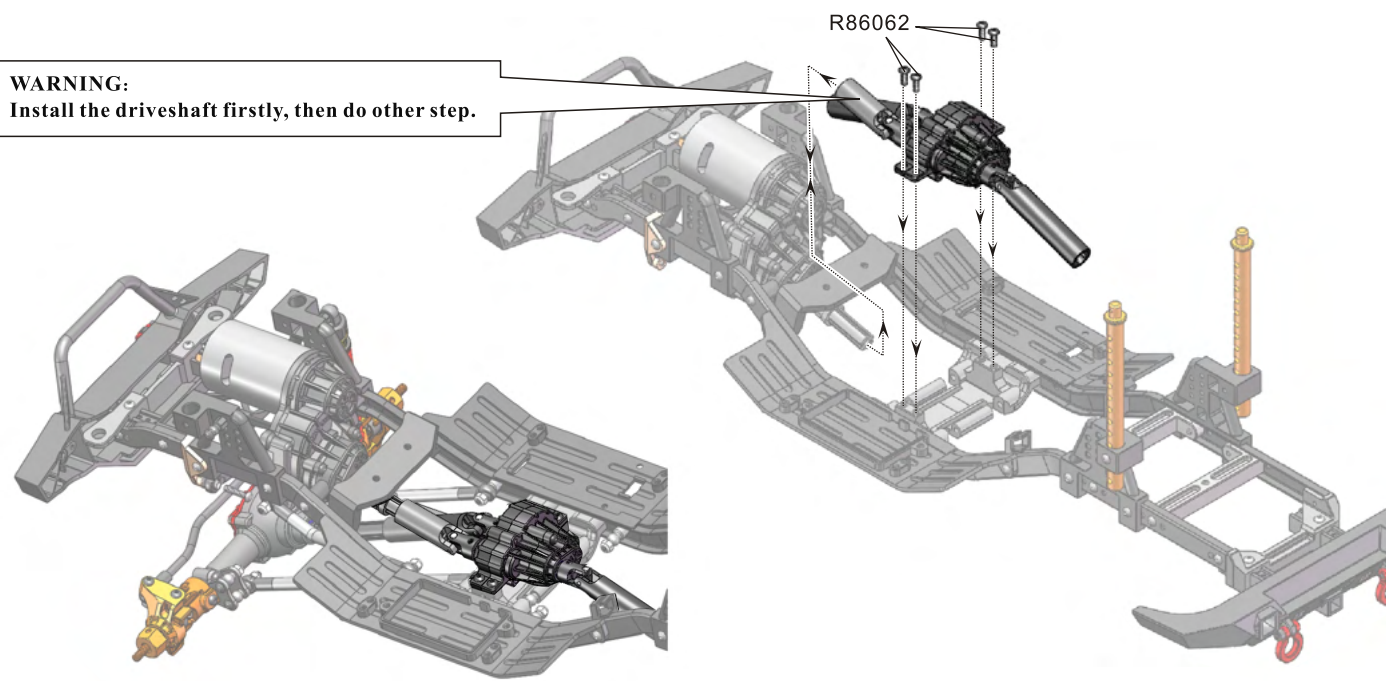

### FRONT COMPONENT ASSEMBLY

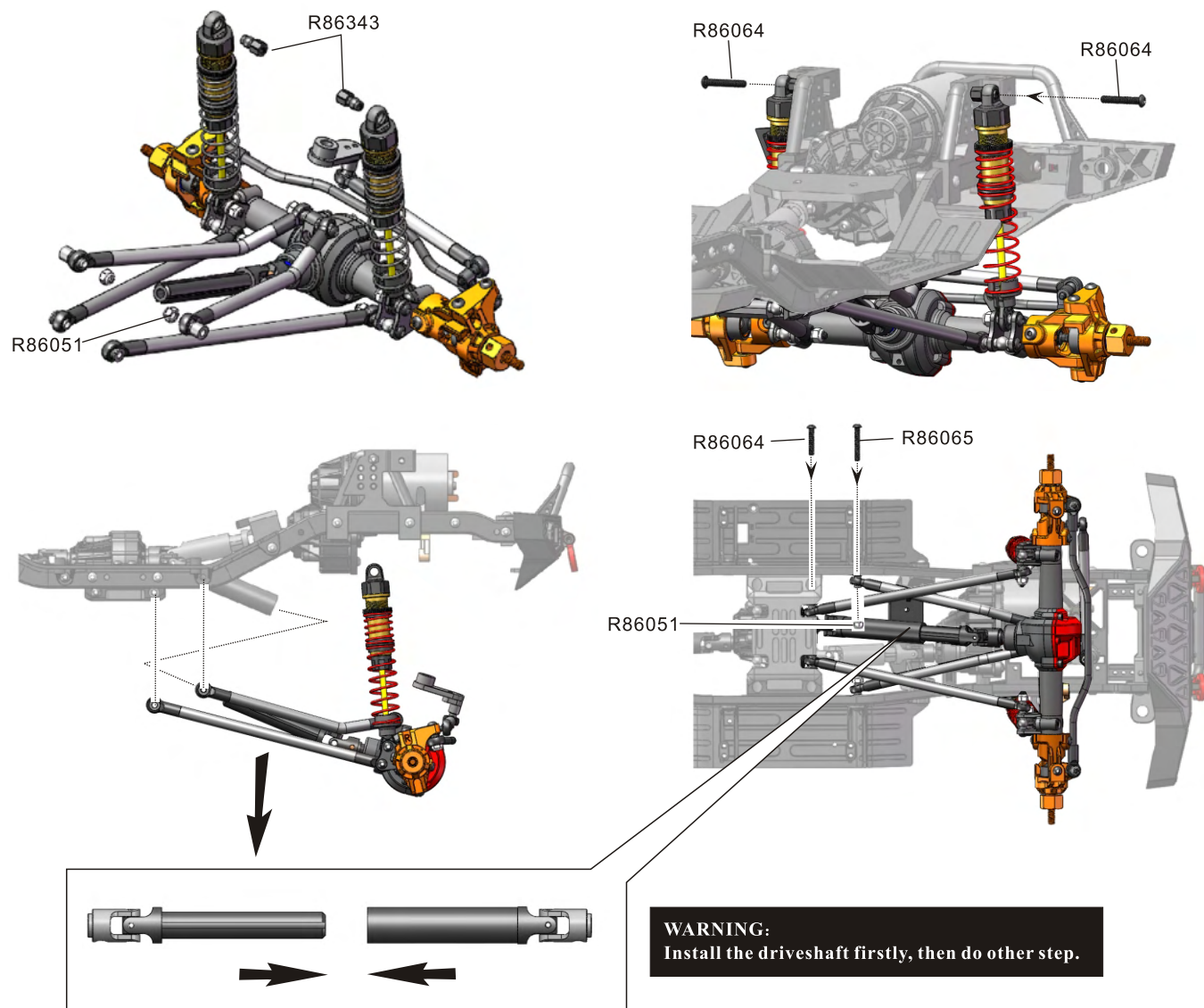

### REAR COMPONENT ASSEMBLY

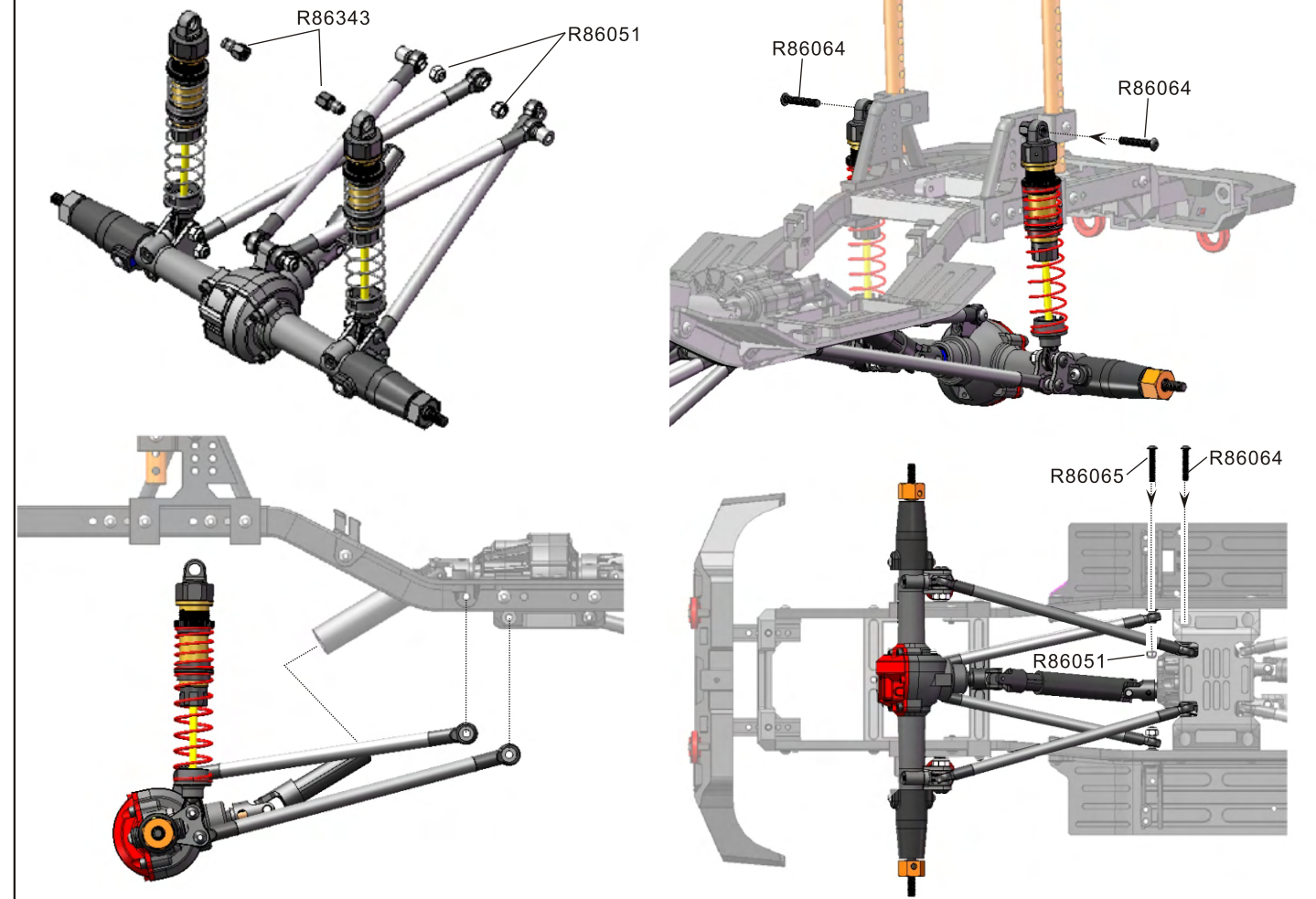

### BUFFER BALANCE LEVER INSTALLATION

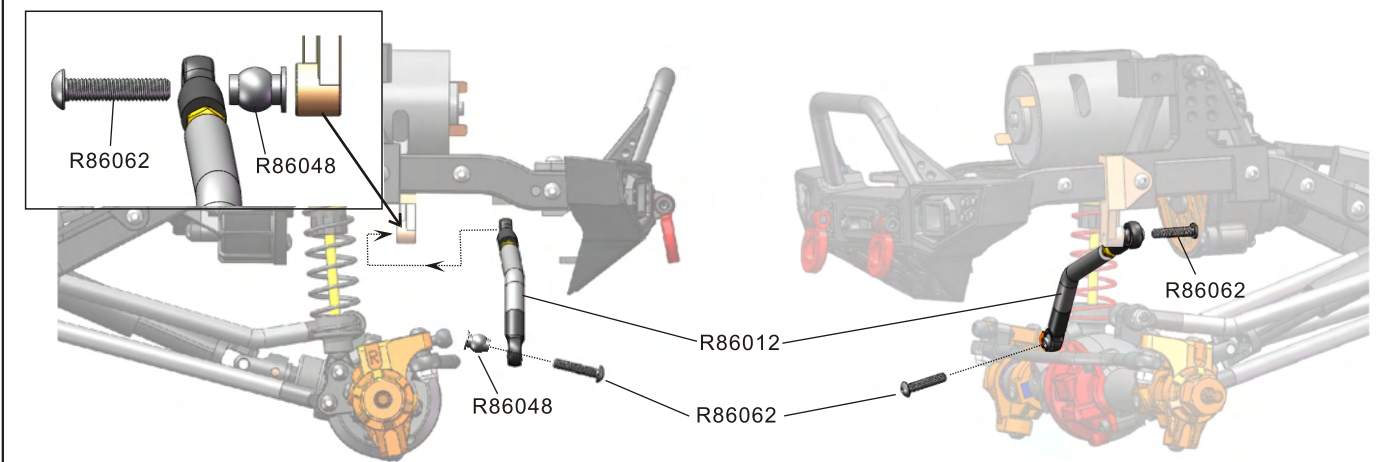









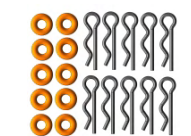

### Spare Part

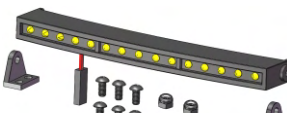

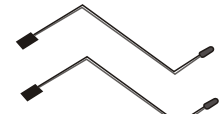
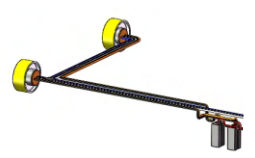

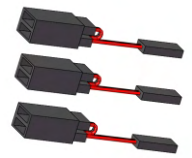

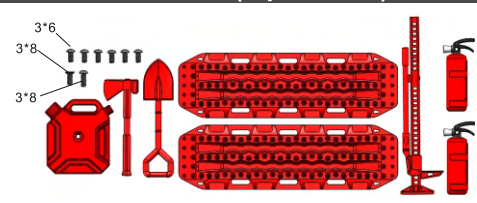



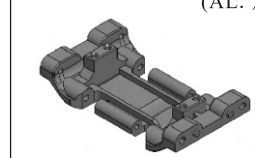

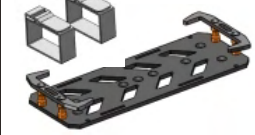

R86062	R86064	R86065	R86012	R86051
2.0 Button Head 3*14	2.0 Button Head 3*18	2.0 Button Head 3*20	Panhard Bar	Nylon Nut M3



## Spare Part

<b>Pre-Assembled Body Combo</b> P86346-1 (Blue) P86346-2 (Yellow) P86346-3 (Gray)	<b>PC Body +Sticker</b> R86363-0 (Clear) R86363-1 (Blue) R86363-2 (Yellow) R86363-3 (Gray)	<b>R86355</b>  Air Grill/Wiper/Door Handle	<b>R86353</b>  Roof Rack	
<b>R86367</b>  R-Clip/O-Ring	<b>R86360</b>  Nylon Nut M4	<b>R86354</b>  Spare Tyre Accessories/Rear View Mirror	<b>R86368</b>  Adjustable LED Lamp	
<b>R86344</b>  Grub Screw Bolt 4*25	<b>R86334</b>  Cornering Light (L/R)	<b>R86352</b>  Angle Eye Function LED Light	<b>R86336</b>  Wire Head 1	<b>R86369</b>  Wire Head 2
<b>R86256</b>  RGT Sticker	<b>02053</b>  R-Clip (Body)	<b>R86366(Optionals)</b> 		

## Upgradable Optionals

<b>P860075- Caster Mounts (AL.) (L/R)</b> 	<b>P860033 - Chassis Plate (AL.)</b> 	<b>P860018-straight axle mount (AL.)</b> 	<b>R86148 - Battery Tray+ Batter Strap</b>  Carbon Fiber	<b>P860005- Mount for Link (AL.)</b> 
<b>P860008- Rear Straight Axle Cover (AL.)</b> 	<b>P860039- Steering Mount</b> 	<b>P860035 - Transmission Gear Housing Set (AL.)</b> 	<b>P860036 - Motor Cover (AL.)</b> 	<b>P860006- Sway Bar Lower Mount (AL.)</b> 
<b>P860067- Alloy Wheel Weight Set 132g</b> 	<b>P860065- Wheel (AL.)</b> 	<b>P860066- Wheel (AL.)</b> 	<b>R86311-CVD Drive Axle (Long)</b> 	<b>R86312-CVD Drive Axle (Short)</b> 

## LIGHT CONNECTION

