

ANTES DE COMENZAR, RECOPILE TODO EL MATERIAL DE APOYO PARA EL MONTAJE: Instrucciones de montaje / ilustraciones paso a paso / planos y plantillas impresos a escala.

PREPARACIÓN DEL MATERIAL: Para poder identificar correctamente las piezas precortadas, antes de extraerlas de las planchas de madera, marque en ellas la misma numeración que aparece en la hoja "IP" (identificación de piezas), incluida en las instrucciones.

INICIO DEL MONTAJE: Con la ayuda de un cúter y procurando no colocar los dedos en la línea de corte, desprenda las piezas de las planchas eliminando los pequeños nervios que las sujetan. Seguidamente lije con suavidad las piezas con papel de lija de grano fino, para eliminar el repelo de las mismas. El orden numérico del paso a paso indica el orden de elaboración y colocación de las piezas. Es importante comprobar el ajuste de las piezas antes de pegarlas definitivamente.

LISTONES Y VARILLAS: Los modelos incorporan varios tipos de listones y varillas para elaborar las diferentes piezas. La lista de piezas proporciona información sobre el tipo de material y medidas. En algunos casos es conveniente ajustar las medidas sobre el propio modelo, conforme avanzamos en el montaje. De esta manera se consigue un mejor ajuste.

PEGAMENTOS RECOMENDADOS: Cola blanca o de carpintero. Para las uniones de piezas de madera y de todas aquellas piezas que no ofrezcan resistencia.

Pegamento rápido. Para piezas que sean difíciles de sostener y que necesiten un secado casi instantáneo.

Cola de contacto o de zapatero. Para todas aquellas piezas que se forren con chapas finas de madera o metal. En todos los casos, lea siempre las instrucciones de uso del fabricante.

SERVICIO DE ATENCIÓN AL CLIENTE: Para cualquier duda o información sobre el montaje de nuestros productos, puede contactar con nuestro Servicio Técnico en la dirección:

www.occre.com. Le atenderemos con mucho gusto.

BEFORE STARTING, MAKE SURE YOU HAVE ALL THE SUPPORT MATERIAL FOR ASSEMBLING THE MODEL:

Assembly Instructions / Step by step pictures / Plans and templates printed to scale.

PREPARING THE MATERIAL: In order to correctly identify the precut parts, before removing them from the wooden sheets, mark on them the same numbers that appear on the "IP"

(Part Identification) Sheet included with the instructions.

STARTING THE ASSEMBLY: Using a cutter, and making sure you do not put your fingers along the cutting line, remove the parts from the wooden sheets, eliminating the small sprues that hold them in place. In continuation smoothly sand down the parts, using fine grain sandpaper, to eliminate the pickup of the parts. The numerical order indicates the order in which the different parts must be made up and fitted.

STRIPS AND RODS: These models incorporate a variety of different types of strips and rods with which to make up the different parts of the kit. The list of parts proportions information on the type of material and measurements. In some cases it is advisable to adjust the measurements on the basis of the model itself, as assembly progresses. In this way you will achieve a better fit.

RECOMMENDED GLUES: White, or carpenter's glue: For joining pieces of wood together. Mainly used for gluing together the skeleton. Quick-drying glue. For parts that are difficult to hold in their final position and which need to set instantly. Recommended for fitting small parts. Contact or cobbler's glue. For gluing into place the parts that are covered with fine wood veneer to set instantly. In all cases, always follow the manufacturer's recommendations.

CUSTOMER ATTENTION SERVICE: In the case of whatsoever doubt or further information that you may require regarding the assembly of our products, please contact our Technical Service online at the address: www.occre.com. We will be delighted to attend to you.

AVANT DE COMMENCER, VÉRIFIEZ TOUT LE MATÉRIEL DE SOUTIEN POUR LE MONTAGE:

PRÉPARATION DU MATÉRIEL: Pour pouvoir identifier correctement les pièces prédécoupées, avant de les extraire des planches de bois, inscrivez sur elles la même numérotation qui apparaît sur la page « IP » (identification des pièces) comprise dans les instructions.

DÉBUT DU MONTAGE: À l'aide d'un cutter, et en essayant de ne pas poser les doigts sur la ligne de découpe, séparez les pièces des planches en éliminant les petits nerfs qui les retiennent. Puis poncez doucement les pièces à l'aide d'un papier de verre à grain fin, pour éliminer le contrefil. L'ordre numérique des étapes photographiques et des plans indique l'ordre d'élaboration et d'installation des pièces.

LISTEAUX ET BAGUETTES: Les modèles intègrent plusieurs types de listeaux et de baguettes destinés à confectionner les différentes pièces. La liste des pièces indique le type de matériau et les dimensions des pièces. Il est parfois recommandé d'ajuster les mesures sur le modèle lui-même, au fur et à mesure que nous avançons dans le montage. De cette manière, on obtient un meilleur réglage.

COLLES RECOMMANDÉES: Colle blanche ou de menuisier: Pour les unions de pièces en bois et de toutes les pièces qui n'offrent pas de résistance. Colle à séchage rapide: Pour les pièces qui sont difficiles à maintenir dans leur position et qui requièrent un séchage pratiquement instantané. Colle de contact ou de cordonnier: Pour toutes les pièces qui sont recouvertes de fines plaques de bois ou de métal. Dans tous les cas, lisez toujours les instructions d'utilisation du fabricant.

SERVICE CLIENT: Pour toute question ou information concernant le montage de nos produits, vous pouvez contacter notre Service Technique à l'adresse suivante: www.occre.com.

Nous répondrons avec plaisir à vos questions.

PRIMA D'INIZIARE, RIUNIRE TUTTO IL MATERIALE D'APPOGGIO PER IL MONTAGGIO: Istruzioni di montaggio, immagini passo per passo, planimetrie e modelli stampati in scala.

PREPARAZIONE DEL MATERIALE: Per poter identificare in maniera corretta i pezzi che sono stati ritagliati, prima di estrarli dai blister di legno occorre segnarli con la stessa numerazione che è indicata nella pagina "IP" (Identificazione pezzi) che si trova nelle istruzioni.

INIZIO DEL MONTAGGIO: Con l'aiuto di un cutter, ed evitando di collocare le dita lungo la linea di taglio, separare i pezzi dai blister eliminando i piccoli nervi che li mantengono attaccati.

In seguito, scartavetrare con delicatezza i pezzi, utilizzando una carta vetrata a grana fine, onde eliminare le sbavature degli stess. L'ordine numerico del passo per passo indica l'ordine d'elaborazione e di collocazione dei pezzi. È importante verificare che questi combacino bene, prima d'incollarli definitivamente.

ASTE E BACCHETTE: I modelli sono dotati di vari tipi di aste e bacchette per formare i diversi pezzi. L'elenco dei pezzi offre informazioni sul tipo di materiale e sulle misure. In alcuni casi è conveniente modificarne le misure quando sono sul modello, man mano che si avanza nel montaggio. In questo modo si potrà ottenere che combacino meglio.

COLLE RACCOMANDATE: Colla bianca o da falegname: Per unire tra loro i pezzi in legno e tutti quei pezzi che non presentino resistenza. Colla rapida: Per i pezzi difficili da sostenere e per i quali sia necessaria un'asciugatura quasi istantanea. Colla a contatto o da calzolaio: Per tutti quei pezzi che vengono rivestiti con fine lastre di legno o di metallo. In ogni caso, leggere sempre le istruzioni d'uso del produttore.

SERVIZIO ASSISTENZA CLIENTE: Per qualsiasi dubbio o informazione sul montaggio dei nostri prodotti, contattare il nostro Servizio Tecnico al seguente indirizzo: www.occre.com.

Seremo lieti di potervi aiutare.

BEVOR SIE MIT DEM ZUSAMMENBAU BEGINNEN, LEGEN SIE SICH BITTE ALLE HILFSMATERIALIEN FÜR DIE MONTAGE BEREIT:

Bastelanleitung / Maßstabgerechte Skizzen und Schablonen / Skizzen und Vorlagen.

VORBEREITUNG DER MATERIALIEN: Damit die einzelnen Bauteile korrekt zugeordnet werden können, empfehlen wir, auf den Holzplättchen vor dem Herausnehmen mit einem Bleistift die Nummer auf dem Blatt IP (Identifikation Teile) zu markieren.

BEGINN DES ZUSAMMENBAUS: Die Teile mit einem Schneidwerkzeug (Cutter) herauslösen und die kleinen Befestigungsenden entfernen. Dabei darauf achten, die Finger nicht zu verletzen. Danach die Teile vorsichtig mit feinem Schmirgelpapier säubern, um ausgefranste Ränder zu entfernen. Die Nummernfolge der Schritte auf Fotos und Skizzen gibt an, in welcher Reihenfolge die Teile zusammengebaut werden.

LEISTEN UND STÄBE: Die Modelle enthalten mehrere Arten von Leisten und Stäben, aus denen die einzelnen Teile des Bausatzes geformt werden. In einigen Fällen kann es angebracht sein, die Maße im Zuge des Zusammenbaus entsprechend dem Modell anzupassen. Auf diese Weise wird eine bessere Passform erricht.

EMPFOHLENE KLEBSTOFFE: Weißleim (Tischlerleim): Zum Kleben von Strukturteilen und allen nachgiebigen Teilen. Sekundenkleber: Für schwer zu haltende Teile, die schnell verklebt werden müssen. Kontaktkleber (Schusterleim): Für alle Teile, die mit dünnen Holz- oder Metallstücken zum Beplanken oder Verkleiden beklebt werden. Bitte beachten Sie stets die Hinweise des Herstellers.

UNSER KUNDENDIENST: Bei Fragen zum Aufbau unserer Modelle steht Ihnen unser Kundendienst zur Verfügung. Sie erreichen uns online unter: www.occre.com.

Wir stehen Ihnen gern mit Rat und Tipps zur Verfügung.

A. Utilice una superficie plana y estable para pegar las piezas A1 y A2, y refuerce su unión con las piezas A3. Siguiendo el orden alfanumérico inserte y pegue las piezas indicadas en las figuras. Antes de encolar las cuadernas, verifique que encajan correctamente en su posición haciendo "tope" en los encajes correspondientes de la falsa quilla. Es importante que las cuadernas queden completamente perpendiculares a la falsa quilla para que posteriormente encajen bien las cubiertas. Para esta operación utilice como adhesivo cola blanca, (Ref.19200).

B. Pegue los refuerzos B1. Después, corte la porción de la cuaderna que le indican las imágenes con una sierra. Continúe fijando las piezas que le indican las imágenes.

C. Lije la parte superior de las cuadernas para facilitar la colocación de las cubiertas. Inserte y pegue las piezas C1 a C4. Utilice una sargenta o pinza para mantener las piezas unidas y con un taladro realice un orificio $\varnothing 12\text{mm}$, que atraviese la quilla. Esta operación debe realizarla con sumo cuidado para no dañar las piezas. Inserte, **sin pegar**, la pieza C5, en el orificio. Esta pieza protegerá de roturas la zona mientras manipula el casco. Coloque el casco boca abajo y comience a lijar empezando desde proa y avanzando hacia popa. Debe desbastar las aristas de las cuadernas, pero sin deformar su forma original. El lijado del casco ha de quedar simétrico, es decir, que el lateral derecho ha de quedar igual que el izquierdo. Para la zona media del casco, utilice un taco lijador con mayor superficie. El lijado debe ser progresivo y suave. Compruebe con un listón, que el lijado es correcto. Para ello, debe deslizar el listón, sobre las cuadernas, para ver cómo se ajusta a su forma.

D y E. Coloque las cubiertas D1 y D2 en el casco, **sin pegar**, e inmovilícelas con cinta de carroceros. Estas cubiertas darán estabilidad al casco mientras lo manipula, pero no debe pegarlas al casco. Comience el forrado del casco con los listones D3. Si los listones estuvieran muy secos y se le rompen al curvarlos, sumérjalos en agua unos veinte minutos. Con esta operación, recuperarán flexibilidad. Después, séquelos con un paño. Debe pegar el primer listón desde la proa hasta la sexta cuaderna, con cola blanca, (Ref.19200). Después, deberá clavarlo con puntas A. Pegue dos listones más D3 para dar continuidad al primer listón hasta la parte trasera del casco. Los demás listones del forro debe pegarlos a las cuadernas y entre sí, con cola blanca y fijarlos con puntas. Continúe pegando listones desde proa hasta popa para forrar el casco entero. Deberá cortar a medida y ajustar las piezas para que encajen en los huecos. Si en algún punto le ha quedado algún listón suelto, puede aplicar pegamento de secado rápido. Si le ha quedado algún listón más hundido, pegue otro encima y después, lijelo. Después, retire las cubiertas D1 y D2 y resérvelas.

F. Si va a hacer navegable este barco, deberá impermeabilizarlo. Para ello, aplique (barniz marino), a todas las piezas del interior del casco incluyendo el forro. Continúe pegando las piezas que le indican las imágenes. Después, presente las piezas F3 y F4, **sin pegar**, y trace el centro longitudinal del casco. Esta línea servirá de guía para forrar las cubiertas. Aplique cola de contacto, (cola de zapatero), y forre las cubiertas con las chapas F5. Corte los sobrantes de las chapas que sobresalen de las cubiertas.

G. Forre también las cubiertas F3 y F4. Lije todas las cubiertas. Aplíqueles barniz marino si va a hacer el barco navegable. En caso contrario, aplique barniz satinado, (Ref.19209). Sumerja las G3 y G4 en agua para que recuperen flexibilidad. Después, utilice una plancha para aplicar calor y poder curvar las piezas sin que se rompan. Pegue las piezas G3 y G4 con pegamento rápido, (cianocrilato). Seguidamente, adapte y pegue los listones G5. Ajuste y pegue la pieza G6. Diluya un poco de cola blanca, (Ref.19200), con agua para que pueda aplicarla ligeramente y se filtre entre las juntas de los listones. Reserve el casco hasta que la cola se seque. Con esta operación se unificará el forro del casco ganando así consistencia.

H e I. Lije todo el exterior del casco para dejarlo fino y unificar sus superficies. Lime las cabezas de las puntas con una lima plana hasta que queden enrasadas con el forro. Debe quedar suave y sin desniveles. Ajuste y pegue las piezas H1, H2 y H3. Aplique masilla tapa-grietas, (Ref.19143), a todo el casco y cuando se haya secado lijelo. Repita la misma operación hasta obtener un acabado fino. Aplique imprimación, (Ref.19142), y vuelva a lijar.

J. Sitúe el casco sobre una superficie plana y estable. Coloque algún objeto de 35mm de altura bajo la zona de proa del casco, e inmovilícelo. Con un par de porciones de algún listón, elabore una pieza como la que le muestra la imagen, para alojar un rotulador. Mantenga el casco inmovilizado y trace con el rotulador la línea de flotación. Utilice cinta de carroceros para enmascarar el casco. Pinte la parte inferior del casco con pintura de color rojo oscuro, (Ref.19383). Para esta operación puede utilizar pincel o aerógrafo. En el caso de utilizar aerógrafo, diluya la pintura con aproximadamente un 20% de agua. Pinte la parte superior del casco con pintura de color negro, (Ref.19301). Si no va a hacer navegable el barco, prepare y pinte el timón J1.

K. Pinte toda la cubierta con pintura de color rojo oscuro, (Ref.19383). Pinte también las piezas F3 y F4 del mismo color rojo oscuro. Pinte las piezas K1, unas de color negro, (Ref.19301), y otras de color amarillo, (Ref.19306). Pegue las piezas K1 de color negro, en posición plana en la cubierta del casco y las amarillas en el exterior. Pinte de color negro, (Ref.19301), las piezas K2 a K5 y péguelas como le indican las imágenes.

L. Elabore las piezas L1 y pintelas de color negro, (Ref.19301). Pinte también las piezas L2 de color negro, y cuando se hayan secado, utilice una esponja-lija para eliminar la pintura de encima de las letras. Esta operación realícela pasando la lija horizontalmente sobre la pieza. **No realice las siguientes operaciones si no desea hacer navegable el barco.** Aplique barniz marino a todo el exterior del barco. Realice un orificio pasante de $\varnothing 8\text{mm}$ en el casco, en posición vertical. Este orificio debe atravesar el casco. Inserte las piezas L3 y L4. Por la parte interior del casco, coloque las piezas L5 y L6 y corte el sobrante de la pieza L3. Inserte el conjunto de las piezas L7 desde el exterior del casco, y coloque la pieza L12. Selle la unión de estas piezas con el casco, con adhesivo epoxi, para evitar que entre agua cuando navegue. Coloque las demás piezas que le indican las imágenes. **En el caso de no querer hacer navegable el barco**, elabore y pinte las piezas L17, L18 y L19. Inserte y pegue las piezas de forma definitiva.

M. En el caso de querer hacer navegable el barco, deberá adquirir los componentes electrónicos y mecánicos necesarios. En el esquema y en el plano de sección del barco, le indicamos cómo y dónde deberían ir colocados los diferentes componentes.

N a P. Construya las estructuras siguiendo las imágenes. Utilice cinta de carroceros para aislar las estructuras y poder decorarlas con precisión. Forre la cubierta P1 con los listones P2 y con cola de contacto, (cola de zapatero). Vaya abriendo aquellos orificios que le indican las imágenes para no perderlos de vista. Inserte y pegue los pilarotes P4 con pegamento, (cianocrilato). Inserte los hilos P5 para elaborar las barandas. Después, pintelas de color blanco, (Ref.19300). Utilice la plantilla PL-01 para tomar medidas y ubicar las diferentes piezas.

Q a U. Continúe construyendo las estructuras con las piezas y los colores que le indican las imágenes. Recuerde que las dos cubiertas de la parte trasera del barco no deben de pegarse al casco. Estas serán aperturas que permitirán acceder al interior del casco para poder ajustar los componentes de motorización. Algunas piezas deberá pintarlas de color negro, (Ref.19301), y destacar sus relieves con pintura de color plata, (Ref.19382).

V y W. Construya la chimenea siguiendo el orden alfanumérico de las imágenes y las indicaciones de los planos, que están impresos a escala 1/1.

X e Y. Construya las barcas, y enmasille y lije sus cascos. Elabore la pieza X34 con la tela y con la ayuda de la plantilla impresa en el plano. Pegue la tela alrededor de la barca con cola blanca. Después, pinte las barcas de color blanco, (Ref.19300).

Z. Continúe construyendo estructuras siguiendo las indicaciones de las imágenes. **No pegue** el techo de la cabina de mando a la estructura, podrá dejarlo practicable por si desea en alguna ocasión iluminarlo. Vaya añadiendo las diferentes piezas a las estructuras, pero **no pegue** la estructura principal al casco. Construya el mástil principal y los dos de las banderas siguiendo las indicaciones de los planos. Después, insértelos y péguelos a la estructura del barco. Construya y decore la peana con las piezas Z54 a Z57.

ARBOLADURA

Para elaborar los mástiles, el primer paso a seguir será cortar las varillas según las medidas que indica la lista de piezas, o bien tomarlas directamente de los planos que están impresos a escala 1/1.

Todos los mástiles y vergas tienen cierta conicidad que se deberá realizar.

Para realizar la conicidad a los mástiles, lije las varillas, (con un lijador), aumentando el desgaste de ésta a medida que se acerca al extremo donde se quiere disminuir el diámetro.

Haga rodar la varilla para que el desgaste sea igual por todo el contorno hasta conseguir llegar al diámetro que indica el plano.

Para elaborar la conicidad de las vergas, realice las mismas operaciones, pero esta vez a ambos extremos de la varilla.

Deberá teñir o pintar las varillas en función del modelo que esté construyendo.

Para realizar correctamente los mástiles de este modelo se deberá tener en cuenta:

- Los planos
- Las fotos de detalle de los mástiles
- Las medidas y descripción de materiales de la lista de piezas
- Las hojas "IP" de identificación de piezas
- La plantilla PL-01

Los mástiles se deberán barnizar y algunas de las piezas que los componen se deberán pintar. Véanse las fotos generales de detalle de los mástiles.

Una vez montados y barnizados, deberán colocarles los aparejos, (estrobos, cuadernales, cáncamos, motones, etc.), y fijarlos al barco.

Los mástiles se deben introducir hasta hacer tope en los encajes de la falsa quilla.

JARCIA

Para elaborar la jarcia de este barco, siga el orden alfabético de las figuras impresas de los planos, que indican el orden de colocación: de hilos, vigotas, motones, velas, etc, destacados en color rojo. La lista de piezas le orientará sobre el tipo de materiales y medidas a utilizar.

A. Use a flat, stable surface glue parts A1 and A2, and reinforce the joints using parts A3. Following the alphanumeric order, insert and glue the parts as shown in the illustrations. Before gluing the frames, check that they fit correctly in their position by fitting them into the corresponding sockets of the false keel. It is important that the frames are completely perpendicular to the false keel so that the decks fit well afterwards. Use white glue for this operation (Ref.19200).

B. Glue reinforcements B1. Then cut off the portion of the frame with a saw as shown in the illustration. Continue to fix the pieces as shown in the illustrations.

C. Sand the top of the frames to facilitate fitting the decks. Insert and glue parts C1 to C4. Use a clamp to hold the pieces together and drill a 12 mm hole through the keel. This operation must be carried out carefully to avoid damaging the parts. Insert part C5, into the hole, **but DO NOT GLUE IT**. This piece will protect the area from breakage while handling the hull. Place the hull upside down and sand from bow to stern. You must roughen the edges of the frames, but without spoiling their original shape. The sanded hull must be symmetrical; that is, the right side must be identical to the left. Use a sanding block of larger surface area for the central part of the hull. Sanding must be progressive and smooth. Use a plank to check that the sanding is correct. To do so, you must slide it over the frames and see how it fits the shape.

D and E. Place the decks D1 and D2 on the hull, **but do not glue them**. Fix them with masking tape. These decks will stabilise the hull for handling, but you should not glue them to the hull. Start the lining the hull with the D3 planks. If the planks are very dry and break when you bend them, soak them in water for twenty minutes. This will make them flexible. Then, dry them with a cloth. Use white glue to stick the first plank from the bow to the sixth frame (Ref.19200). Then, nail it using A-pins. Glue two more D3 planks to give continuity to the first strake to the stern of the hull. The other planks of the lining must be glued to the frames and to each other with white glue and then fixed with pins. Continue gluing planks from bow to stern to line the entire hull. You will need to cut to them size and adjust them to fit the gaps. If at any planks are loose, you can apply instant glue. If one or more planks are lower than the others and you have some left, stick them on the recessed ones and then sand them down. Then remove decks D1 and D2 and set them aside.

F. If you are going to sail this boat, you must waterproof it. To do so, apply marine varnish to all the pieces inside the hull including the lining. Continue gluing the pieces as illustrated. Then, offer up pieces F3 and F4, **but do not glue them**. Draw the longitudinal centreline of the hull. This line will serve as a guide for planking the decks. Apply contact glue, (shoemaker's glue), and line the decks with F5 plates. Cut the leftovers of the plates that protrude from the decks.

G. Also cover decks F3 and F4. Sand all the decks. Apply marine varnish if you are going to make the boat navigable. If necessary, apply satin varnish (Ref.19209). Soak the G3 and G4 in water to make them flexible. Then, heat them with an iron so you can bend them without breaking them. Glue the G3 and G4 parts using instant glue, (cyanoacrylate). Then adapt and glue the G5 planks. Adjust and glue piece G6. Dilute some white glue with water (Ref.19200) so you can apply it sparingly and it will creep between the plank joints. Set aside the hull until the adhesive dries. This operation fixes the whole hull lining, making it stronger.

H and I. Sand the entire outside of the hull until it is smooth and even. File the heads of the pins using a flat file until they are flush with the lining. It should be smooth and even. Adjust and glue pieces H1, H2 and H3. Apply filler (Ref.19143) to the whole hull and when it has dried, sand it. Repeat the same operation until you get a fine finish. Apply primer (Ref.19142) and re-sand.

J. Place the hull on a flat, stable surface. Place any 35 mm high object under the bow area of the hull and immobilize it. Using a couple of pieces of planking, make a piece to hold a marker, like the one shown. Keep the hull steady and trace the waterline with the pen. Use masking tape to mask the hull. Paint the lower part of the hull with dark red paint, (Ref.19383). You can use a brush or airbrush for this. If you use an airbrush, dilute the paint with approximately 20% water. Paint the upper hull with black paint (Ref.19301). If you are not going to make the boat navigable, prepare and paint the rudder, J1.

K. Paint the entire deck with dark red paint (Ref.19383). Also paint pieces F3 and F4 in the same dark red colour. Paint some K1 pieces black (Ref.19301) and others yellow (Ref.19306). Glue the black K1 pieces flat on the hull deck and the yellow ones on the outside. Paint pieces K2 to K5 (Ref.19301) black and glue them as shown in the illustrations.

L. Make pieces L1 and paint them black (Ref.19301). Also paint the L2 pieces black and when they have dried, use a sanding sponge to remove the paint from the letters. This is carried out by passing the sandpaper horizontally over the piece. **Do not perform the following operations if you do not want to make the ship navigable.** Apply marine varnish to the entire exterior of the ship. Make a 8 mm vertical hole through the hull. This hole must go through the hull. Insert parts L3 and L4. On the inside of the hull, fit pieces L5 and L6 and cut the excess off piece L3. Insert the set of L7 parts from the outside of the hull, and fit part L12. Use epoxy adhesive to seal the joint of these pieces with the hull to prevent water from entering when sailing. Fit the other pieces as illustrated. **If you do not want to make the boat navigable**, make and paint pieces L17, L18 and L19. Insert and glue the pieces fast.

M. If you wish to make the boat navigable, you must buy the necessary electronic and mechanical components. In the diagram and in the section plan of the ship, we show how and where the different components should be fitted.

N to P. Build the structures as shown in the illustrations. Use masking tape to protect them so you can decorate them precisely. Line deck P1 with planks P2 and fix with contact glue, (shoemaker's glue). Open the holes as shown in the illustrations so as not to lose sight of them. Insert and glue the P4 stanchions with instant glue, (cyanoacrylate). Insert wires P5 to make the guardrails. Paint them white (Ref.19300). Use template PL-01 to take measurements and locate the different parts.

Q to U. Continue building the structures with the pieces and colours shown in the illustrations. Remember that the two decks at the rear of the boat must not be attached to the hull. These are the openings to the inside of the hull to adjust the motor components. Some pieces must be painted black (Ref.19301) with silver highlights (Ref.19382).

V and W. Build the chimney following the alphanumeric order as shown in the illustrations and the plans, which are printed on a 1/1 scale.

X and Y. Build the boats and caulk and sand their hulls. Make part X34 using the fabric and the template printed on the drawing. Glue the cloth around the boat with white glue. Then paint the boats white (Ref.19300).

Z. Build the other structures following the directions in the illustrations. **Do not glue** the roof of the wheelhouse to the structure, you can leave it loose in case you want to fit a light in the future. Continue fitting the pieces to the structures, but **do not glue** the main structure to the hull. Build the main mast and both of the flags following the directions on the plans. Then, fit them and glue them to the ship's structure. Build and decorate the pedestal with pieces Z54 to Z57.

MASTS AND SPARS

In order to make up the masts the first step is to cut the rods to size, as indicated in the parts list, or by taking measurements directly from the plans, which are printed in 1/1 scale.

All of the masts and spars have to have a certain conical shape, which they will have to be given.

In order to achieve this conical shape for the masts, sand down the rod (using a sander), increasing the amount of sanding down as you get closer to the end at which you want to decrease the diameter. Turn the rod so that you sand it down evenly on all sides, until achieving the diameter indicated in the plan.

To achieve this conical shape for the spars carry out the above operations but in this case evenly reducing the diameter at both ends of the rod.

The rods will have to be stained or painted, depending on the model that you are building.

To correctly make up the mast for this model you must take into account:

- The plans
- The close-up photos of the masts and spars
- The measurements and material descriptions of the parts list
- The "PI" parts identification sheets
- Template PL-01

The masts and spars need to be varnished, while some of the parts that make them up are meant to be painted. Examine the general and close-up photos of the masts

Once the mast and spars has been assembled and varnished fix the tackle (slings, blocks, eyebolts, clump blocks, etc.) into place on the ship. The masts will have to be fully inserted into the sockets prepared to receive them in the false keel.

SAILS AND RIGGING

In order to make up the running gear for this ship follow the alphabetic order of the images printed on the plans, indicating the order for fitting the (ropes, clump blocks, blocks, sails, etc.) highlighted in red. In combination with the parts list this will serve as a guide with regard to the type of material to be used and the measurements.

A method for simulating the aging of the sails is to soak them in an infusion of tea, without boiling, and then leaving them to dry all wrinkled up. Fit them in place without ironing so that they will have a certain consistency.

A. Utilisez une surface plane et stable pour coller les pièces A1 et A2, et renforcer le point d'union à l'aide des pièces A3. En suivant l'ordre alphanumérique, insérez et collez les pièces indiquées sur les figures. Avant de coller les couples, vérifiez qu'ils s'ajustent exactement à leur place et font office de "cale" dans les emboîtements correspondants de la fausse quille. Il est important que les couples restent totalement perpendiculaires à la fausse quille afin que les ponts viennent s'emboîter correctement par la suite. Pour cette opération, utilisez comme adhésif de la colle blanche (Réf. 19200).

B. Collez les renforts B1. Puis, découpez la portion du couple comme indiqué sur les images, avec une scie. Continuez à fixer les pièces indiquées sur les images.

C. Poncez la partie supérieure des couples afin de faciliter l'installation des ponts. Insérez et collez les pièces C1 à C4. Utilisez un pince-étau ou une pince pour maintenir les pièces assemblées, et à l'aide d'une perceuse, exécutez un orifice de $\varnothing 12\text{mm}$, traversant la quille. Cette opération devra être exécutée avec grand soin afin de ne pas endommager les pièces. Insérez, **sans coller**, la pièce C5 dans l'orifice. Cette pièce évitera toute cassure de cette zone pendant la manipulation de la coque. Placez la coque à l'envers, et commencez à poncer en allant de la proue vers la poupe. Vous affinerez les arrêtes des couples, mais en veillant à ne pas altérer sa forme originale. Le ponçage de la coque doit être symétrique, ce qui signifie que le côté droit doit être identique au gauche. Pour la zone moyenne de la coque, utilisez un pavé ponceur de plus grande surface. Le ponçage doit être progressif et doux. Vérifiez à l'aide d'une latte que le ponçage est correct. Pour cela, faites glisser la latte sur les couples pour voir comme elle s'ajuste à sa forme.

D et E. Placez les ponts D1 et D2 sur la coque, **sans coller**, et immobilisez-les à l'aide de ruban de masquage. Ces ponts donneront de la stabilité à la coque pendant la manipulation, mais il ne faut pas les coller à la coque. Commencez le bordage de la coque à l'aide des lattes D3. Si les lattes sont très sèches, et cassent en les courbant, plongez-les dans de l'eau pendant vingt minutes environ. Grâce à cette opération, elles gagneront en souplesse. Puis séchez-les avec un chiffon. Vous pouvez coller la première latte depuis la proue jusqu'au sixième couple, avec de la colle blanche (Réf. 19200). Puis, vous devrez la clouer avec des pointes A. Collez deux autres lattes D3 pour prolonger la première jusqu'à la partie arrière de la coque. Les autres lattes du bordé doivent être collées aux couples, et entre elles, avec de la colle blanche puis fixées avec des pointes. Poursuivez, en collant de la proue à la poupe pour border l'ensemble de la coque. Vous devrez couper sur mesure et ajuster les pièces pour qu'elles s'emboîtent dans les zones creuses. Si quelque part une latte n'est pas fixée, vous pouvez appliquer de la colle à séchage rapide. Si une latte s'est enfoncée, collez-en une par-dessus, puis poncez. Retirez ensuite les ponts D1 et D2, et mettez-les de côté.

F. Si vous voulez rendre ce bateau navigable, vous allez devoir l'imperméabiliser. Pour cela, appliquez du vernis marin sur toutes les pièces de l'intérieur de la coque y compris le bordé. Continuez à coller les pièces indiquées sur les images. Puis, présentez les pièces F3 et F4, **sans coller**, et tracez le milieu longitudinal de la coque. Cette ligne servira de guide pour border les ponts. Appliquez de la colle de contact (colle de cordonnier), et bordez les ponts à l'aide des plaques F5. Découpez les parties des plaques qui dépassent des ponts.

G. Bordez également les ponts F3 et F4. Poncez tous les ponts. Vernissez avec du vernis marin, si le bateau doit être navigable. Dans ce cas, appliquez un vernis satiné (Réf. 19209). Plongez les pièces G3 et G4 dans de l'eau pour les rendre plus souples. Puis, utilisez une planche pour appliquer de la chaleur et pouvoir courber les pièces sans qu'elles cassent. Collez les pièces G3 et G4 avec de la colle rapide (cyanoacrylate). Puis, adaptez et collez les lattes G5. Ajustez et collez la pièce G6. Diluez un peu de colle blanche (Réf. 19200) avec de l'eau afin de l'appliquer plus légèrement, et qu'elle filtre entre les jointures des lattes. Mettez la coque de côté, pour que la colle sèche. Avec cette opération, le bordage de la coque sera unifié, ce qui lui fera gagner en consistance.

H et I. Poncez tout l'extérieur de la coque pour la laisser fine et unifier les surfaces. Limez les têtes des pointes avec une lime plate, jusqu'à ce qu'elles ne dépassent plus du bordage. Il doit rester doux et régulier. Ajustez et collez les pièces H1, H2 et H3. Appliquez l'enduit pour reboucher les fissures (Réf. 19143) sur toute la coque, puis une fois sec, poncez. Renouvelez l'opération jusqu'à obtenir une finition fine. Appliquez de l'apprêt (Réf. 19142) puis poncez à nouveau.

J. Placez la coque sur une surface plane et stable. Placez un objet de 35 mm de hauteur sous la zone de proue de la coque, et immobilisez-le. Avec des portions de lattes, élaborer une pièce comme montré sur l'image, pour y placer un feutre. Maintenez la coque immobile et tracez à l'aide du feutre la ligne de flottaison. Utilisez du ruban de masquage pour recouvrir la coque. Peignez la sous-marine de la coque avec de la peinture de couleur rouge foncé (Réf. 19383). Pour cette opération vous pouvez utiliser un pinceau ou un spray. Si vous utilisez un spray, diluez la peinture avec environ 20 % d'eau. Peignez la partie supérieure de la coque avec de la peinture de couleur noire (Réf.19301). Si le bateau ne doit pas être navigable, préparez et peignez le gouvernail J1.

K. Peignez toute la coque avec de la peinture de couleur rouge foncé (Réf. 19383). Peignez également les pièces F3 et F4 de cette même couleur rouge foncé. Peignez les pièces K1, les unes en noir (Réf. 19301), et les autres de couleur jaune (Réf. 19306). Collez les pièces K1 de couleur noire, à plat sur le pont de la coque et les jaunes à l'extérieur. Peignez en noir (Réf. 19301), les pièces K2 à K5 et collez-les comme indiqué sur les images.

L. Élaborez les pièces L1 et peignez-les de couleur noire (Réf. 19301). Peignez également les pièces L2 de couleur noire, et lorsqu'elles seront sèches, utilisez une éponge à poncer pour éliminer la peinture sur les lettres. Exécutez cette opération en passant la ponceuse à l'horizontale sur la pièce. **Ne réalisez pas les opérations suivantes si le bateau ne doit pas être navigable.** Appliquez le vernis marin sur la totalité de l'extérieur du bateau. Exécutez un orifice de $\varnothing 8\text{mm}$ sur la coque, à la verticale. Cet orifice doit traverser la coque. Insérez les pièces L3 et L4. Par la partie intérieure de la coque, placez les pièces L5 et L6 et coupez ce qui dépasse de la pièce L3. Insérez l'ensemble des pièces L7 par l'extérieur de la coque, et placez la pièce L12. Scellez l'union de ces pièces à la coque, avec de l'adhésif époxy, pour éviter la pénétration d'eau pendant la navigation. Placez les autres pièces comme indiqué sur les images. **Si le bateau ne doit pas être navigable**, confectionnez et peignez les pièces L17, L18 et L19. Insérez et collez les pièces de manière définitive.

M. Si le bateau doit être navigable, vous devrez acquérir les composants électroniques et mécaniques nécessaires. Sur le schéma et le plan de section du bateau, nous vous indiquons comment et où devront être placés les différents composants.

N à P. Construisez les structures en suivant les images. Utilisez du ruban de masquage pour isoler les structures et les décorer avec précision. Bordez le pont P1 avec des lattes P2 et de la colle de contact (colle de cordonnier) Ouvrez les orifices comme indiqué sur les images afin de ne pas les perdre de vue. Insérez et collez les piliers P4 avec de la colle (cyanoacrylate). Insérez les fils P5 pour former les garde-corps. Puis peignez-les de couleur blanche (Réf. 19300). Utilisez le gabarit PL-01 pour prendre les mesures et placer les différentes pièces.

Q à U. Continuez à construire les structures avec les pièces et les couleurs indiquées sur les images. N'oubliez pas que les deux ponts de la partie arrière du bateau ne doivent pas être collés à la coque. Ce seront des ouvertures qui permettront d'accéder à l'intérieur de la coque, afin de pouvoir ajuster les composants de commandes. Il faudra peindre certaines pièces de couleur noire (Réf.19301), et faire ressortir les reliefs avec de la peinture argentée (Réf. 19382).

V et W. Confectionnez la cheminée en suivant l'ordre alphanumérique des images et les indications des plans, qui sont imprimés à l'échelle 1/1.

X et Y. Confectionnez les barques, enduisez et poncez leurs coques. Confectionnez la pièce X34 avec la toile et à l'aide du gabarit imprimé sur le plan. Collez la toile autour de la barque avec de la colle blanche. Puis, peignez les barques de couleur blanche (Réf. 19300).

Z. Poursuivez la construction des structures en suivant les indications des images. **Ne collez pas** le plafond de la cabine de commandement à la structure, faites-en sorte qu'il reste praticable, si vous souhaitez l'illuminer à certaines occasions. Ajoutez peu à peu les différentes pièces aux structures, mais **ne collez pas** la structure principale à la coque. Construisez le grand mât et les deux drapeaux en suivant les indications des plans. Puis, insérez-les et collez-les à la structure du bateau. Construisez et décorez le socle à l'aide des pièces Z54 à Z57.

MÂTURE

La première chose à faire pour confectionner les mâts est de couper les baguettes aux dimensions indiquées dans la liste des pièces ou de prendre ces mesures directement des plans qui sont imprimés à l'échelle 1/1.

Tous les mâts et les vergues possèdent une certaine conicité qui doit être travaillée.

Pour réaliser la conicité des mâts, poncer les baguettes (avec une ponceuse) en augmentant le dégrossissage au fur et à mesure qu'on s'approche de l'extrémité où l'on souhaite diminuer le diamètre. Faire rouler la baguette afin que l'usure soit égale sur tout le contour jusqu'à ce qu'on obtienne le diamètre indiqué sur le plan.

Effectuer les mêmes opérations pour réaliser la conicité des vergues mais, dans ce cas, aux deux extrémités de la baguette.

Il faudra teinter ou peindre les baguettes en fonction de la maquette qui sera construite.

Pour réaliser correctement les mâts de cette maquette, il faudra tenir compte :

- Des plans
- Des photos de détail des mâts.
- Des dimensions et de la description des matériaux de la liste des pièces.
- Des feuilles « IP » d'identification des pièces.
- Le patron PL-01

Les mâts devront être vernis et certaines des pièces qui les composent devront être peintes. Voir les photos générales de détail des mâts.

Lorsque les mâts seront montés et vernis, on placera leurs appareils (estropes, moufles, pitons, poulies, etc.) et on les attachera au bateau. Les mâts doivent être introduits de sorte qu'ils s'emboîtent à fond contre la fausse quille.

GRÉEMENT

Pour réaliser le gréement de ce bateau, on suivra l'ordre alphabétique des figures imprimées des plans, qui indiquent l'ordre de montage (fils, caps de mouton, poulies, etc.) mis en évidence en rouge. La liste des pièces indique le type de matériaux et les dimensions à utiliser.

Pour simuler le vieillissement des voiles, on peut les faire tremper dans une infusion de thé, sans les faire bouillir, et les laisser sécher bien chiffonnées. Les voiles seront placées non repassées afin d'avoir du volume.

A. Utilizzare una superficie piana e stabile per incollare i pezzi A1 e A2 e rinforzare la loro giunzione con i pezzi A3. Seguendo l'ordine alfanumerico, inserire e incollare i pezzi indicati nelle figure. Prima di incollare i telai, verificare che si inseriscano correttamente in posizione, incastrandoli nelle corrispondenti sedi della falsa chiglia. È importante che i telai siano completamente perpendicolari alla falsa chiglia in modo che i ponti si adattino correttamente. Per questa operazione utilizzare come adesivo la colla bianca (cod. 19200).

B. Incollare i rinforzi B1. Quindi ritagliare con una sega la porzione di telaio indicata nelle immagini. Continuare a incollare i pezzi indicati nelle immagini.

C. Carteggiare la parte superiore dei telai per facilitare il montaggio dei ponti. Inserire e incollare i pezzi da C1 a C4. Utilizzare un morsetto o una pinza per tenere insieme le parti e praticare un foro $\varnothing 12$ mm attraverso la chiglia. Questa operazione deve essere eseguita con molta attenzione per evitare di danneggiare le parti. Inserire, **senza incollare**, il pezzo C5 nel foro. Questo pezzo proteggerà l'area da rotture durante la manipolazione dello scafo. Capovolgere lo scafo e iniziare a carteggiare partendo dalla prua e procedendo verso poppa. I bordi dei telai devono essere puliti dalle sbavature, ma senza deformare la loro forma originale. Lo scafo deve essere carteggiato in modo simmetrico, cioè il lato destro deve essere uguale a quello sinistro. Per la parte centrale dello scafo, utilizzare un blocco di levigatura con una superficie maggiore. La levigatura deve essere progressiva e uniforme. Utilizzare un listello per verificare che la levigatura sia corretta. A tal fine, far scorrere il listello sui telai per vedere come si adatta alla loro forma.

D ed E. Posizionare i ponti D1 e D2 sullo scafo, **senza incollarli**, e fissarli con nastro adesivo. Questi ponti conferiscono stabilità allo scafo durante la movimentazione, ma non devono essere incollati allo scafo. Iniziare a rivestire lo scafo con i listelli D3. Se i listelli sono troppo secchi e si rompono quando li si piega, immergerli in acqua per circa venti minuti. Questo li renderà nuovamente elastici. Successivamente, asciugare con un panno. Incollare il primo listello dell'arco al sesto telaio con colla bianca (rif. 19200). Incollare altri due listelli D3 per dare continuità dal primo listello al retro dello scafo. I restanti listelli del tavolato devono essere incollati al telaio e tra loro con colla bianca e inchiodati con chiodini. Continuare a incollare i listelli da prua a poppa per rivestire l'intero scafo. È necessario tagliare a misura e adattare i pezzi ai fori. Se in qualche punto i listelli sono allentati, è possibile applicare una colla ad asciugatura rapida. Se ci sono altri listelli che cedono, incollatene un altro e poi carteggiare. Rimuovere quindi i ponti D1 e D2 e metterli da parte.

F. Se si vuole rendere questa barca idonea alla navigazione, è necessario impermeabilizzarla. A tal fine, applicare la vernice marina su tutte le parti interne dello scafo, compreso il rivestimento. Continuare a incollare le parti come mostrato nelle immagini. Quindi, applicare i pezzi F3 e F4, **senza incollarli**, e disegnare il centro longitudinale dello scafo. Questa linea servirà da guida per il rivestimento dei ponti. Applicare la colla a contatto (colla da calzolaio) e foderare i ponti con le lastre F5. Tagliare le parti delle lastre in eccesso che sporgono dai ponti.

G. Rivestire anche i ponti F3 e F4. Carteggiare tutti i ponti. Applicare la vernice marina se l'imbarcazione deve essere resa idonea alla navigazione. In caso contrario, applicare la vernice satinata (rif. 19209). Immergere G3 e G4 in acqua per ripristinarne la flessibilità. Quindi utilizzare un ferro da stiro per applicare il calore e piegare i pezzi senza romperli. Incollare le parti G3 e G4 con colla rapida (cianacrilica). Quindi, montare e incollare i listelli G5. Montare e incollare il pezzo G6. Diluire un po' di colla bianca (rif. 19200) con acqua, in modo da poterla applicare leggermente e farla penetrare tra le giunzioni dei listelli. Mettere da parte lo scafo finché la colla non si asciughi. Questo uniformerà il rivestimento dello scafo e lo renderà più consistente.

H e I. Carteggiare tutta la parte esterna dello scafo per ottenere una finitura fine e per uniformare le superfici dello scafo. Limare le teste dei chiodini con una lima piatta finché non sono a filo con il rivestimento. Il tutto deve risultare liscio e uniforme. Montare e incollare le parti H1, H2 e H3. Applicare lo stucco copri-crepe (rif. 19143) su tutto lo scafo e, una volta asciugato, carteggiare. Ripetere la stessa operazione fino a ottenere una finitura fine. Applicare il primer (rif. 19142) e carteggiare nuovamente.

J. Posizionare lo scafo su una superficie piana e stabile. Posizionare un oggetto alto 35 mm sotto la zona di prua dello scafo, al fine d'immobilizzarlo. Con un paio di pezzi di listello, realizzare un pezzo come quello mostrato nella foto, per contenere un pennarello. Mantenere lo scafo immobilizzato e tracciare la linea di galleggiamento con il pennarello. Utilizzare il nastro adesivo per mascherare lo scafo. Dipingere la parte inferiore dello scafo con vernice rosso scuro (rif. 19383). Questo può essere fatto a pennello o con l'aerografo. Nel caso dell'aerografia, diluire la vernice con circa il 20% di acqua. Dipingere la parte superiore dello scafo con vernice nera (rif. 19301). Se l'imbarcazione non deve essere resa navigabile, preparare e verniciare il timone J1.

K. Dipingere l'intero ponte con vernice rosso scuro (rif. 19383). Dipingere anche le parti F3 e F4 con lo stesso colore rosso scuro. Dipingere i pezzi K1, alcuni neri (rif. 19301) e altri gialli (rif. 19306). Incollare i pezzi K1 di colore nero in posizione piana sul ponte dello scafo e quelli gialli all'esterno. Dipingere di nero (rif. 19301) le parti da K2 a K5 e incollarle come mostrato nelle immagini.

L. Preparare i pezzi L1 e dipingerli di nero (rif. 19301). Dipingere anche i pezzi L2 in nero e, quando si sono asciugati, usare una spugna abrasiva per rimuovere la vernice sopra le lettere. Questa operazione deve essere eseguita passando la carta vetrata orizzontalmente sul pezzo. **Non eseguire le seguenti operazioni se non si desidera rendere l'imbarcazione idonea alla navigazione.** Applicare la vernice marina su tutto l'esterno dell'imbarcazione. Praticare un foro da $\varnothing 8$ mm nello scafo, in posizione verticale. Questo foro deve passare attraverso lo scafo. Inserire le parti L3 e L4. All'interno dello scafo, montare le parti L5 e L6 e tagliare l'eccesso della parte L3. Inserire il set di pezzi L7 dall'esterno dello scafo e montare il pezzo L12. Sigillare la giunzione tra queste parti e lo scafo con adesivo epossidico per evitare che l'acqua penetri durante la navigazione. Montare le altre parti come mostrato nelle immagini. Se **non si vuole rendere la barca navigabile**, realizzare e dipingere i pezzi L17, L18 e L19. Inserire e incollare definitivamente i pezzi.

M. Se si vuole rendere l'imbarcazione idonea alla navigazione, è necessario acquistare i componenti elettronici e meccanici necessari. Nel diagramma e nel piano di sezione della barca, vi mostriamo come e dove devono essere posizionati i diversi componenti.

Da N a P. Costruire le strutture secondo le immagini. Utilizzare il nastro adesivo per isolare le strutture e poterle decorare con precisione. Rivestire il ponte P1 con i listelli P2 e incollare a contatto (colla per calzolaio). Aprire i fori come mostrato nelle immagini per non perderli di vista. Inserire e incollare i pilastri P4 con la colla (cianacrilica). Inserire i filetti P5 per realizzare le ringhiere. Quindi dipingere di bianco (rif. 19300). Utilizzare la sagoma PL-01 per prendere le misure e posizionare i vari pezzi.

Da Q a U. Continuate a costruire le strutture con le parti e i colori indicati nelle immagini. Occorre ricordare che i due ponti sul retro della barca non devono essere incollati allo scafo. Si tratta di aperture che consentono di accedere all'interno dello scafo per poter montare i componenti del motore. Alcune parti devono essere dipinte di nero (rif. 19301) e i loro rilievi devono essere evidenziati con vernice argentata (Rif. 19382).

V e W. Costruire la canna fumaria seguendo l'ordine alfanumerico delle immagini e le indicazioni dei piani, che sono stampati in scala 1/1.

X e Y. Costruire le barche, stuccarne e levigarne gli scafi. Realizzare il pezzo X34 con il tessuto e con l'aiuto della sagoma stampata sul piano. Incollare il tessuto intorno alla barca con la colla bianca. Quindi dipingere le barche di bianco (rif. 19300).

Z. Continuare a costruire le strutture seguendo le indicazioni delle immagini. **Non incollare** il tetto della cabina di pilotaggio alla struttura, lo si può lasciare aperto nel caso in cui lo si voglia illuminare. Aggiungere le varie parti alle strutture, ma **non incollare** la struttura principale allo scafo. Costruire l'albero principale e i due alberi delle bandiere come indicato nei piani. Quindi inserirli e incollarli alla struttura della nave. Costruire e decorare la base con le parti da Z54 a Z57.

ALBERATURA

Per realizzare l'alberatura, il primo passo da seguire sarà quello di tagliare le aste secondo le misure indicate nell'elenco dei pezzi, oppure prenderle direttamente dalle planimetrie che sono stampate in scala 1/1.

Tutti gli alberi e i pennoni hanno una certa conicità che si dovrà ottenere.

Per ottenere la conicità degli alberi, occorre scartavetrare le aste (con una smerigliatrice), aumentando l'azione della stessa a misura che ci si avvicina all'estremità dove si deve diminuire il diametro. Far girare l'asta affinché la smerigliatura sia uguale su tutto il contorno, fino ad arrivare al diametro indicato nella planimetria.

Per ottenere la conicità dei pennoni, realizzare le stesse operazioni, ma in questo caso su entrambe le estremità dell'asta. Si dovranno verniciare o tingere le aste in funzione del modello che si stia realizzando.

Per realizzare gli alberi di questo modello in maniera corretta si dovranno utilizzare:

- Le planimetrie;
- Le foto dettagliate degli alberi;
- Le misure e la descrizione dei materiali nell'elenco dei pezzi;
- Le pagine "IP" con l'identificazione dei pezzi.
- La sagoma PL-01

Gli alberi devono essere smaltati ed alcuni dei pezzi che li compongono devono essere verniciati. Vedi le foto generali dettagliate degli alberi.

Una volta montati e smaltati, devono essere collocati gli attrezzi (stropi, quarnali, golfare, bozzelli, ecc.) e fissati al vascello.

Gli alberi devono essere introdotti fino in fondo negli appositi incastri della falsa chiglia.

SARTIA

Per elaborare la sartia di questo vascello occorre seguire l'ordine alfabetico delle figure stampate delle planimetrie, che indicano l'ordine di collocazione delle cime, delle bigotte, dei bozzelli, delle vele, ecc., risaltati in colore rosso. L'elenco dei pezzi serve ad orientare in merito al tipo di materiali ed alle misure da utilizzare.

Per simulare l'invecchiamento delle vele, queste possono essere bagnate con te, senza farle bollire, e poi lasciarle asciugare mantenendole ben arrugate.

Poi si collocano senza stirarle, affinché mantengano corpo.

A. Auf einer ebenen und stabilen Oberfläche die Teile A1 und A2 zusammenkleben und die Verbindung mit den Teilen A3 verstärken. Die auf den Abbildungen gezeigten Teile in der angegebenen Reihenfolge einsetzen und aufkleben. Vor dem Aufkleben der Spanten sicherstellen, dass die sie korrekt sitzen und mit den dazugehörigen Einkerbungen des falschen Kiels abschließen. Die Spanten müssen vollkommen senkrecht auf dem falschen Kiel stehen, damit danach die Decks gut eingesetzt werden können. Für diesen Schritt weißen Leim (Ref.19200) verwenden.

B. Die Verstärkungen B1 ankleben. Anschließend den auf den Abbildungen gezeigten Teil des Spanten mit einer Säge zuschneiden. Die Teile wie auf den Abbildungen zu sehen aufkleben.

C. Die Oberseite der Spanten glatt schmirgeln, damit sich die Decks leichter aufsetzen lassen. Die Teile C1 bis C4 einsetzen und verkleben. Die Teile mit einer Klammer zusammenhalten und mit einem Bohrer ein $\varnothing 12$ mm-Loch durch den Kiel bohren. Dieser Vorgang muss mit äußerster Sorgfalt durchgeführt werden, um eine Beschädigung der Teile zu vermeiden. **Ohne Kleben** Teil C5 in die Öffnung einsetzen. Dieses Teil schützt den Bereich vor Beschädigungen bei der Arbeit am Schiffsrumpf. Den Rumpf mit der Oberseite nach unten anbringen und vom Bug in Richtung Heck glatt schleifen. Die Kanten der Spanten glätten, aber dabei nicht das ursprüngliche Profil verändern. Beim Glätten des Rumpfs darauf achten, dass beide Seiten symmetrisch zueinander sein müssen. Für den mittleren Rumpfbereich einen Sander mit großer Schleifoberfläche verwenden. Die Oberfläche nach und nach vorsichtig glätten. Mit der Leiste testen, ob eine gleichmäßige Oberfläche hergestellt wurde. Dazu die Leiste über die Spanten fahren und prüfen, wie sie sich der Form anpasst.

D und E. Die Deckteile D1 und D2 auf den Rumpf aufsetzen, **ohne sie anzukleben**, und mit Kreppband an ihrem Platz halten. Diese Decks sorgen dafür, dass der Rumpf während der Handhabung stabil ist, dürfen aber aber aufgeklebt werden. Zuerst den Schiffsrumpf mit den Leisten D3 beplanken. Wenn die Leisten sehr trocken sind, ca. 20 Minuten in Wasser einweichen, damit sie nicht brechen. Damit werden sie biegsamer. Anschließend mit einem Tuch trockenreiben. Die erste Leiste vom Bug bis zum sechsten Spant aufkleben. Dazu weißen Leim (Ref.19200) verwenden. Danach mit A-Stiften befestigen. Zwei weitere Leisten D3 aufkleben, um an die erste Leiste auf der Rückseite des Rumpfs anzuknüpfen. Die übrigen Leisten an die Spanten und aneinander kleben und mit weißem Leim und Stiften befestigen. Die Beplankung des Rumpfs fortsetzen und Leisten von Bug nach Heck aufkleben. Die Teile für die Zwischenräume nach Maß zurechtschneiden. Lose Planken mit Sekundenkleber festkleben. Wenn eine Planke zu tief eingesunken ist, eine weitere Planke darüber setzen und abschleifen. Anschließend die Deckteile D1 und D2 entfernen und beiseite legen.

F. Wenn das Boot „seetüchtig“ werden soll, muss es wasserdicht gemacht werden. Dazu alle Teile im Inneren des Rumpfs, einschließlich der Beplankung, lackieren (mit Marinelack). Die Teile, die auf den Abbildungen zu sehen sind, aufkleben. Anschließend die Teile F3 und F4 aufsetzen, **ohne sie anzukleben**, und die Längsmittlinie des Rumpfs nachzeichnen. Diese Linie dient als Richtschnur für das Beplanken der Decks. Kontaktkleber (Schusterleim) auftragen und die Decks mit den Leisten F5 verkleiden. Die überstehenden Teile der Leisten abschneiden.

G. Danach auch die Decks F3 und F4 mit Planken versehen. Alle Decks glatt schmirgeln. Wenn das Boot „seetüchtig“ werden soll, alle Teile im Inneren des Rumpfs, einschließlich der Beplankung, mit Marinelack lackieren, um es wasserdicht zu machen. Falls erforderlich, seidenmatten Lack auf (Ref. 19209). Die Leisten G3 und G4 in Wasser einweichen, damit sie biegsamer werden. Anschließend die Teile mit einer Dose biegen, ohne sie zu zerbrechen. Die Teile G3 und G4 mit Sekundenkleber (Cyanacrylat) aufkleben. Anschließend die Leisten G5 einpassen und aufkleben. Teil G6 anpassen und aufkleben. Etwas weißen Leim (Ref.19200) mit Wasser verdünnen, um ihn leichter auftragen zu können, so dass er sich in den Zwischenräume zwischen den Leisten verteilt. Rumpf beiseite stellen, bis der Leim getrocknet ist. Mit diesem Verfahren wird die Rumpfbeplankung einheitlich und gewinnt an Stabilität.

H und I. Anschließend den gesamten Rumpf glatt schmirgeln, so dass eine gleichmäßige Fläche entsteht. Die Stiftköpfe mit einer Feile glatt feilen, bis sie auf einer Höhe mit den Plankenreihen sind. Es muss eine glatte und gleichmäßige Oberfläche entstehen. Die Teile H1, H2 und H3 anpassen und aufkleben. Eine Schicht Fugenkitt (Ref.19143) auf die gesamte Rumpfverkleidung auftragen und nach dem Trocknen glattschmirgeln. Den Vorgang wiederholen, bis eine gleichmäßige Oberfläche entstanden ist. Grundierung auftragen (Ref. 19142), und erneut glatt schmirgeln.

J. Den Rumpf auf eine ebene und stabile Fläche setzen. Einen 35 mm hohen Gegenstand unter den Bugbereich des Rumpfs setzen und den Rumpf darauf fixieren. In eine Leiste wie auf der Abbildung gezeigt eine Öffnung anbringen und einen Filzstift einsetzen. Den Rumpf fixieren und die Wasserlinie mit dem Markierstift einzeichnen. Den Rumpf mit Kreppband abkleben. Die Unterseite des Rumpfs dunkelrot lackieren (Lack, Ref.19383). Für diesen Vorgang einen Pinsel oder eine Airbrush-Spritzpistole verwenden. Wenn Sie eine Airbrush verwenden, die Farbe mit etwa 20% Wasser verdünnen. Die Oberseite des Rumpfs schwarz lackieren (Lack, Ref.19301). Wenn das Boot nicht „seetüchtig“ werden soll, das Ruder J1 anfertigen und anmalen.

K. Das gesamte Deck mit dunkelroter Farbe (Ref.19383) lackieren. Die Teile F3 und F4 in der gleichen dunkelroten Farbe anmalen. Einige Teile K1 schwarz (Ref. 19301) und die anderen gelb (Ref. 19306) anmalen. Die schwarzen K1-Teile flach auf das Deck des Rumpfs und die gelben an die Außenseite kleben. Die Teile K2 bis K5 schwarz anmalen (Ref. 19301) und wie auf den Abbildungen gezeigt aufkleben.

L. Die Teile L1 anfertigen und schwarz (Ref. 19301) anmalen. Die Teile L2 ebenfalls schwarz anmalen und nach dem Trocknen die Farbe auf den Buchstaben mit Schwamm und Sandpapier entfernen. Bei diesem Vorgang wird das Schleifpapier horizontal über das Werkstück geführt. **Die folgenden Schritte nicht durchführen, wenn das Boot nicht „seetüchtig“ werden soll.** Die gesamte Außenseite des Bootes mit Marinelack behandeln. Eine Öffnung mit $\varnothing 8$ mm in den Rumpf bohren, und zwar in senkrechter Position. Diese Öffnung muss durch den Rumpf gehen. Die Teile L3 und L4 einführen. Die Teile L5 und L6 von der Innenseite des Rumpfes einsetzen und die überstehenden Enden von Teil L3 abschneiden. Die Baugruppe L7 von der Außenseite des Rumpfs her einsetzen und Teil L12 montieren. Diese Teile mit Epoxidkleber am Rumpf versiegeln, um das Eindringen von Wasser zu verhindern. Die anderen Teile, die auf den Abbildungen zu sehen sind, aufsetzen. **Wenn das Boot nicht „seetüchtig“ werden soll**, die Teile L17, L18 und L19 anfertigen und anmalen. Die Teile aufsetzen und festkleben.

M. Wenn das Boot auf Wasser gefahren werden soll, müssen die erforderlichen elektronischen und mechanischen Komponenten gesondert gekauft werden. Auf der Skizze und im Bastelplan zeigen wir, wie und wo die verschiedenen Komponenten angebracht werden.

N bis P. Die Strukturen wie auf den Abbildungen gezeigt anfertigen. Die Struktur vor dem Lackieren zum Schutz mit Kreppband abkleben. Das Deck P1 auf die Leisten P2 setzen und mit Kontaktkleber (Schusterleim) festkleben. Aufpassen, dass die Öffnungen, die auf den Abbildungen zu sehen sind, offen bleiben. Die Relingständer P4 einsetzen und mit Sekundenkleber (Cyanacrylat) aufkleben. Die Drähte P5 für die Reling einziehen. Anschließend weiß lackieren (Ref. 19300). Mit der Schablone PL-01 Maß nehmen, um die Teile zu positionieren.

Q bis U. Die Strukturen aus den auf den Abbildungen gezeigten Teilen anfertigen und wie gezeigt lackieren. Darauf achten, dass die beiden Decks im hinteren Teil des Schiffs nicht an den Rumpf geklebt werden dürfen. Durch diese Öffnungen erfolgt der Zugang zum Inneren des Rumpfes zum Einbau des Motors. Einige Stücke schwarz lackieren (Ref. 19301), die Reliefs silberfarben absetzen (Ref. 19382).

V und W. Den Schornstein in der auf den Abbildungen angezeigten Reihenfolge entsprechend den Angaben auf den Plänen, die im Maßstab 1/1 gedruckt sind, anfertigen.

X und Y. Die Rettungsboote anfertigen, Kitte auftragen und glatt schmirgeln. Das Teil X34 aus Stoff und mithilfe der auf dem Plan abgedruckten Schablone anfertigen. Den Stoff mit weißem Leim über das Boot kleben. Anschließend die Boote weiß lackieren (Ref. 19300).

Z. Die weiteren Strukturen wie auf den Abbildungen gezeigt anfertigen. Das Kajütendach **nicht** an die Struktur **kleben**, sondern lassen offen lassen, damit später bei Bedarf eine Beleuchtung eingesetzt werden kann. Die Deko-Teile an den Strukturen anbringen, aber die Hauptstruktur **nicht an den Rumpf kleben**. Den Hauptmast und die beiden Fahnenmasten wie auf den Plänen dargestellt anfertigen. Anschließend in die Schiffskonstruktion einsetzen und festkleben. Den Ständer aus den Teilen Z54 bis Z57 anfertigen und dekorieren.

BEMASTUNG

Zur Herstellung der Masten müssen zuerst die Stäbe entsprechend der Maße zurecht geschnitten werden, die in der Teilleiste angegeben sind oder die direkt anhand der Skizze abgemessen wurde. Die Skizzen sind im Maßstab 1/1 angefertigt.

Alle Masten und Rahen müssen leicht konisch verlaufen und vor dem Einbau entsprechen vorbereitet werden.

Um die Masten in Konusform zu bringen, müssen die Masten (mit einer Feile) zurecht geschliffen werden, und zwar in der Form, dass sie nach oben hin verjüngt werden. Die Stäbe dabei drehen und an allen Seiten gleichmäßig abschleifen, bis sie zu dem auf der Skizze angegebenen Durchmesser passen.

Um die Rahen in Konusform zu bringen, ebenso verfahren, allerdings hier an beiden Enden der Stangen.

Die Stäbe in Abhängigkeit von dem Modell färben oder anmalen.

Um die Masten dieses Schiffsbaumodells richtig vorzubereiten, müssen die folgenden Punkte beachtet werden:

- Die Skizzen
- Detailfotos der Masten
- Maße und Materialien der Teilleiste
- IP-Blätter zur Identifikation der Bauteile
- Schablone PL-01

Die Masten müssen lackiert werden und einige der Einzelteile der Masten müssen angemalt werden. Siehe Fotos mit allgemeiner Ansicht der Masten

Nach Aufstellung und Lackierung der Masten wird die Takelung (Stroppe, Rollenblöcke, Ösen, Blockrollen etc.) an den Masten und dann am Schiff befestigt. Die Masten müssen eingesetzt werden, bis sie an die Einkerbungen des falschen Kiels stoßen.

TAKELAGE

Zur Takelung des Schiffsmodells die alphabetische Reihenfolge der Abbildungen befolgen, auf denen die Anbringung der Takelung (Faden, Klampböcke, Blockrollen usw.) erläutert wird. Sie sind in Rot hervorgehoben. Auf der Teilleiste sehen Sie, welche Materialien zum Bau des Modells notwendig sind.

Zur künstlichen Alterung der Segel die Stoffstücke in Tee legen (nicht kochen) und trocknen lassen, bis die Stoffe faltig werden.

Die Segel ohne vorheriges Bügeln anbringen, damit sie Volumen haben.

Lista de piezas / Parts List / Liste des pièces / Teileliste / Elenco delle parti

Nº/No. / N° / Nr. No	Cantidad / Quantity / Quantité / Menge / Quantità	Medidas / Measurements / Dimensions / Maße / Misure	Material / Material / Matériau / Material / Materiale
A1-A2	2	Precortado / Precut / Prédécoupé / Vorgeschnitten / Pretagliatto	Tablero / Plywood / Planche / Sperrholz / Tavola
A3	2	Precortado / Precut / Prédécoupé / Vorgeschnitten / Pretagliatto	Tablero / Plywood / Planche / Sperrholz / Tavola
A4-A14	11	Precortado / Precut / Prédécoupé / Vorgeschnitten / Pretagliatto	Tablero / Plywood / Planche / Sperrholz / Tavola
B1	2	Precortado / Precut / Prédécoupé / Vorgeschnitten / Pretagliatto	Tablero / Plywood / Planche / Sperrholz / Tavola
B2-B3	4	Precortado / Precut / Prédécoupé / Vorgeschnitten / Pretagliatto	Tablero / Plywood / Planche / Sperrholz / Tavola
B4-B5	2	Precortado / Precut / Prédécoupé / Vorgeschnitten / Pretagliatto	Tablero / Plywood / Planche / Sperrholz / Tavola
B6-B7	2	Precortado / Precut / Prédécoupé / Vorgeschnitten / Pretagliatto	Tablero / Plywood / Planche / Sperrholz / Tavola
B8-B14	7	Precortado / Precut / Prédécoupé / Vorgeschnitten / Pretagliatto	Tablero / Plywood / Planche / Sperrholz / Tavola
B15-B17	6	Precortado / Precut / Prédécoupé / Vorgeschnitten / Pretagliatto	Tablero / Plywood / Planche / Sperrholz / Tavola
C1	1	Precortado / Precut / Prédécoupé / Vorgeschnitten / Pretagliatto	Tablero / Plywood / Planche / Sperrholz / Tavola
C2	1	Precortado / Precut / Prédécoupé / Vorgeschnitten / Pretagliatto	Tablero / Plywood / Planche / Sperrholz / Tavola
C3	2	Precortado / Precut / Prédécoupé / Vorgeschnitten / Pretagliatto	Tablero / Plywood / Planche / Sperrholz / Tavola
C4	2	Precortado / Precut / Prédécoupé / Vorgeschnitten / Pretagliatto	Tablero / Plywood / Planche / Sperrholz / Tavola
C5	1	ø12x200	Tilo / Lime wood / Tilleul / Linde / Tiglio
C6	1	2x7x400	Tilo / Lime wood / Tilleul / Linde / Tiglio
D1	1	Precortado / Precut / Prédécoupé / Vorgeschnitten / Pretagliatto	Tablero / Plywood / Planche / Sperrholz / Tavola
D2	1	Precortado / Precut / Prédécoupé / Vorgeschnitten / Pretagliatto	Tablero / Plywood / Planche / Sperrholz / Tavola
D3	30	2x7x400	Tilo / Lime wood / Tilleul / Linde / Tiglio
E1	80	2x7x400	Tilo / Lime wood / Tilleul / Linde / Tiglio
F1	1	Precortado / Precut / Prédécoupé / Vorgeschnitten / Pretagliatto	Tablero / Plywood / Planche / Sperrholz / Tavola
F2	1	Precortado / Precut / Prédécoupé / Vorgeschnitten / Pretagliatto	Tablero / Plywood / Planche / Sperrholz / Tavola
F3	1	Precortado / Precut / Prédécoupé / Vorgeschnitten / Pretagliatto	Tablero / Plywood / Planche / Sperrholz / Tavola
F4	1	Precortado / Precut / Prédécoupé / Vorgeschnitten / Pretagliatto	Tablero / Plywood / Planche / Sperrholz / Tavola
F5	70	0,6x7x400	Sicomoro / Sycamore / Sycomore / Bergahorn / Sicomoro
G1	14	0,6x5x160	Sicomoro / Sycamore / Sycomore / Bergahorn / Sicomoro
G2	12	0,6x7x90	Sicomoro / Sycamore / Sycomore / Bergahorn / Sicomoro
G3-G4	4	Precortado / Precut / Prédécoupé / Vorgeschnitten / Pretagliatto	Tablero / Plywood / Planche / Sperrholz / Tavola
G5	6	2x7x400	Tilo / Lime wood / Tilleul / Linde / Tiglio
G6	1	Precortado / Precut / Prédécoupé / Vorgeschnitten / Pretagliatto	Tablero / Plywood / Planche / Sperrholz / Tavola
H1	1	Precortado / Precut / Prédécoupé / Vorgeschnitten / Pretagliatto	Tablero / Plywood / Planche / Sperrholz / Tavola
H2-H3	2	Precortado / Precut / Prédécoupé / Vorgeschnitten / Pretagliatto	Tablero / Plywood / Planche / Sperrholz / Tavola
i1	5	2x5x400	Tilo / Lime wood / Tilleul / Linde / Tiglio
i2	2	3x5x390	Tilo / Lime wood / Tilleul / Linde / Tiglio
i3	2	2x5x270	Tilo / Lime wood / Tilleul / Linde / Tiglio
J1	1	Precortado / Precut / Prédécoupé / Vorgeschnitten / Pretagliatto	Tablero / Plywood / Planche / Sperrholz / Tavola
K1	10	1x3x400	Tilo / Lime wood / Tilleul / Linde / Tiglio
K2-K4	6	Precortado / Precut / Prédécoupé / Vorgeschnitten / Pretagliatto	Tablero / Plywood / Planche / Sperrholz / Tavola
K5	1	Precortado / Precut / Prédécoupé / Vorgeschnitten / Pretagliatto	Tablero / Plywood / Planche / Sperrholz / Tavola
K6	2	Precortado / Precut / Prédécoupé / Vorgeschnitten / Pretagliatto	Tablero / Plywood / Planche / Sperrholz / Tavola
L1	2	3x5x181	Tilo / Lime wood / Tilleul / Linde / Tiglio
L2	2	Preformado / Prefomed/ Préformé / Vorgeformt / Preformato	Latón / Brass / Latón / Messing / Ottone
L3	1	Preformado / Prefomed/ Préformé / Vorgeformt / Preformato	Composite / Composite / Composite / Composite / Composite
L4	1	Preformado / Prefomed/ Préformé / Vorgeformt / Preformato	Goma / Rubber / Gomme / Gummi / Gomma
L5	1	Preformado / Prefomed/ Préformé / Vorgeformt / Preformato	Metal / Metal / Metal / Metall / Metallo
L6	1	Preformado / Prefomed/ Préformé / Vorgeformt / Preformato	Metal / Metal / Metal / Metall / Metallo

Lista de piezas / Parts List / Liste des pièces / Teileliste / Elenco delle parti

Nº/No. / N° / Nr. No	Cantidad / Quantity / Quantité / Menge / Quantità	Medidas / Measurements / Dimensions / Maße / Misure	Material / Material / Matériau / Material / Materiale
L7	1	Preformado / Prefomed/ Préformé / Vorgeformt / Preformato	Latón / Brass / Latón / Messing / Ottone
L8	2	Preformado / Prefomed/ Préformé / Vorgeformt / Preformato	Metal / Metal / Metal / Metall / Metallo
L9	1	Preformado / Prefomed/ Préformé / Vorgeformt / Preformato	Metal / Metal / Metal / Metall / Metallo
L10	1	Preformado / Prefomed/ Préformé / Vorgeformt / Preformato	Metal / Metal / Metal / Metall / Metallo
L11	1	Preformado / Prefomed/ Préformé / Vorgeformt / Preformato	Composite / Composite / Composite / Composite / Composite
L12	1	Precortado / Precut / Prédécoupé / Vorgeschnitten / Pretagliatto	Tablero / Plywood / Planche / Sperrholz / Tavola
L13	1	Preformado / Prefomed/ Préformé / Vorgeformt / Preformato	Latón / Brass / Latón / Messing / Ottone
L14	1	Preformado / Prefomed/ Préformé / Vorgeformt / Preformato	Composite / Composite / Composite / Composite / Composite
L15	1	Preformado / Prefomed/ Préformé / Vorgeformt / Preformato	Latón / Brass / Latón / Messing / Ottone
L16	1	Preformado / Prefomed/ Préformé / Vorgeformt / Preformato	Latón / Brass / Latón / Messing / Ottone
L17	1	ø12x20	Tilo / Lime wood / Tilleul / Linde / Tiglio
L18	1	Preformado / Prefomed/ Préformé / Vorgeformt / Preformato	Metal / Metal / Metal / Metall / Metallo
L19	1	3x5x66	Tilo / Lime wood / Tilleul / Linde / Tiglio
N1-N5	5	Precortado / Precut / Prédécoupé / Vorgeschnitten / Pretagliatto	Tablero / Plywood / Planche / Sperrholz / Tavola
N6	1	Precortado / Precut / Prédécoupé / Vorgeschnitten / Pretagliatto	Tablero / Plywood / Planche / Sperrholz / Tavola
N7	1	Precortado / Precut / Prédécoupé / Vorgeschnitten / Pretagliatto	Tablero / Plywood / Planche / Sperrholz / Tavola
N8	2	Precortado / Precut / Prédécoupé / Vorgeschnitten / Pretagliatto	Tablero / Plywood / Planche / Sperrholz / Tavola
N9	1	Precortado / Precut / Prédécoupé / Vorgeschnitten / Pretagliatto	Tablero / Plywood / Planche / Sperrholz / Tavola
N10	28	2x5x45	Tilo / Lime wood / Tilleul / Linde / Tiglio
o1	6	Preformado / Prefomed/ Préformé / Vorgeformt / Preformato	Latón / Brass / Latón / Messing / Ottone
o2	11	Preformado / Prefomed/ Préformé / Vorgeformt / Preformato	Latón / Brass / Latón / Messing / Ottone
o3	2	Preformado / Prefomed/ Préformé / Vorgeformt / Preformato	Latón / Brass / Latón / Messing / Ottone
P1	1	Precortado / Precut / Prédécoupé / Vorgeschnitten / Pretagliatto	Tablero / Plywood / Planche / Sperrholz / Tavola
P2	32	0,6x7x400	Sicomoro / Sycamore / Sycomore / Bergahorn / Sicomoro
P3	5	1x3x400	Tilo / Lime wood / Tilleul / Linde / Tiglio
P4	45	Preformado / Prefomed/ Préformé / Vorgeformt / Preformato	Latón / Brass / Latón / Messing / Ottone
P5	26	ø0,50x100	Latón / Brass / Latón / Messing / Ottone
P6	1	Precortado / Precut / Prédécoupé / Vorgeschnitten / Pretagliatto	Tablero / Plywood / Planche / Sperrholz / Tavola
P7	1	2x2x11	Tilo / Lime wood / Tilleul / Linde / Tiglio
P8	2	2x2x30	Tilo / Lime wood / Tilleul / Linde / Tiglio
P9	2	ø0,50x32	Latón / Brass / Latón / Messing / Ottone
P10	2	ø0,50x13	Latón / Brass / Latón / Messing / Ottone
Q1-Q2	3	Preformado / Prefomed/ Préformé / Vorgeformt / Preformato	Latón / Brass / Latón / Messing / Ottone
Q3-Q4	4	Preformado / Prefomed/ Préformé / Vorgeformt / Preformato	Latón / Brass / Latón / Messing / Ottone
Q5	2	Preformado / Prefomed/ Préformé / Vorgeformt / Preformato	Latón / Brass / Latón / Messing / Ottone
Q6	2	Preformado / Prefomed/ Préformé / Vorgeformt / Preformato	Latón / Brass / Latón / Messing / Ottone
Q7	6	ø1,5x40	Latón / Brass / Latón / Messing / Ottone
Q8	1	Preformado / Prefomed/ Préformé / Vorgeformt / Preformato	Metal / Metal / Metal / Metall / Metallo
Q9	1	2x7x70	Tilo / Lime wood / Tilleul / Linde / Tiglio
Q10	2	2x7x16	Tilo / Lime wood / Tilleul / Linde / Tiglio
Q11	1	ø6x70	Tilo / Lime wood / Tilleul / Linde / Tiglio
Q12	1	2x5x74	Tilo / Lime wood / Tilleul / Linde / Tiglio
Q13	2	Preformado / Prefomed/ Préformé / Vorgeformt / Preformato	Metal / Metal / Metal / Metall / Metallo
R1-R4	4	Precortado / Precut / Prédécoupé / Vorgeschnitten / Pretagliatto	Tablero / Plywood / Planche / Sperrholz / Tavola
R5-R6	3	Precortado / Precut / Prédécoupé / Vorgeschnitten / Pretagliatto	Tablero / Plywood / Planche / Sperrholz / Tavola

Lista de piezas / Parts List / Liste des pièces / Teileliste / Elenco delle parti

Nº/No./ N° / Nr. No	Cantidad / Quantity / Quantité / Menge / Quantità	Medidas / Measurements / Dimensions / Maße / Misure	Material / Material / Matériau / Material / Materiale
R7	21	2x5x48	Tilo / Lime wood / Tilleul / Linde / Tiglio
R8	2	Preformado / Prefomed/ Préformé / Vorgeformt / Preformato	Latón / Brass / Latón / Messing / Ottone
R9	3	Preformado / Prefomed/ Préformé / Vorgeformt / Preformato	Latón / Brass / Latón / Messing / Ottone
S1-S6	7	Precortado / Precut / Prédécoupé / Vorgeschnitten / Pretagliatto	Tablero / Plywood / Planche / Sperrholz / Tavola
S7	28	2x5x25	Tilo / Lime wood / Tilleul / Linde / Tiglio
S8	1	Preformado / Prefomed/ Préformé / Vorgeformt / Preformato	Latón / Brass / Latón / Messing / Ottone
S9-S11	4	Preformado / Prefomed/ Préformé / Vorgeformt / Preformato	Acetato / Acetate / Acétate / Acetat / Acetato
T1	1	Precortado / Precut / Prédécoupé / Vorgeschnitten / Pretagliatto	Tablero / Plywood / Planche / Sperrholz / Tavola
T2	1	Precortado / Precut / Prédécoupé / Vorgeschnitten / Pretagliatto	Tablero / Plywood / Planche / Sperrholz / Tavola
T3	1	Preformado / Prefomed/ Préformé / Vorgeformt / Preformato	Latón / Brass / Latón / Messing / Ottone
T4	6	Precortado / Precut / Prédécoupé / Vorgeschnitten / Pretagliatto	Tablero / Plywood / Planche / Sperrholz / Tavola
T5-T6	2	Preformado / Prefomed/ Préformé / Vorgeformt / Preformato	Latón / Brass / Latón / Messing / Ottone
T7	9	0,6x7x32	Sicomoro / Sycamore / Sycomore / Bergahom / Sicomoro
T8	3	1x3x59	Tilo / Lime wood / Tilleul / Linde / Tiglio
T9	2	1x3x215	Tilo / Lime wood / Tilleul / Linde / Tiglio
T10	2	1x3x32	Tilo / Lime wood / Tilleul / Linde / Tiglio
T11	1	2x5x13	Tilo / Lime wood / Tilleul / Linde / Tiglio
T12	1	2x2x13	Tilo / Lime wood / Tilleul / Linde / Tiglio
T13	2	0,6x7x13	Sicomoro / Sycamore / Sycomore / Bergahom / Sicomoro
T14	1	Precortado / Precut / Prédécoupé / Vorgeschnitten / Pretagliatto	Tablero / Plywood / Planche / Sperrholz / Tavola
T15	11	0,6x7x75	Sicomoro / Sycamore / Sycomore / Bergahom / Sicomoro
T16	1	1x3x72	Tilo / Lime wood / Tilleul / Linde / Tiglio
T17	1	1x3x190	Tilo / Lime wood / Tilleul / Linde / Tiglio
T18	17	Preformado / Prefomed/ Préformé / Vorgeformt / Preformato	Latón / Brass / Latón / Messing / Ottone
T19	5	ø0,50x100	Latón / Brass / Latón / Messing / Ottone
U1	1	Preformado / Prefomed/ Préformé / Vorgeformt / Preformato	Metal / Metal / Metal / Metall / Metallo
U2	1	Preformado / Prefomed/ Préformé / Vorgeformt / Preformato	Metal / Metal / Metal / Metall / Metallo
U3	2	ø1x32	Latón / Brass / Latón / Messing / Ottone
U4	1	Preformado / Prefomed/ Préformé / Vorgeformt / Preformato	Metal / Metal / Metal / Metall / Metallo
U5	2	Preformado / Prefomed/ Préformé / Vorgeformt / Preformato	Metal / Metal / Metal / Metall / Metallo
U6-U7	4	Preformado / Prefomed/ Préformé / Vorgeformt / Preformato	Latón / Brass / Latón / Messing / Ottone
U8	5	Preformado / Prefomed/ Préformé / Vorgeformt / Preformato	Latón / Brass / Latón / Messing / Ottone
U9	1	Preformado / Prefomed/ Préformé / Vorgeformt / Preformato	Metal / Metal / Metal / Metall / Metallo
U10	1	Precortado / Precut / Prédécoupé / Vorgeschnitten / Pretagliatto	Tablero / Plywood / Planche / Sperrholz / Tavola
U11	1	Preformado / Prefomed/ Préformé / Vorgeformt / Preformato	Metal / Metal / Metal / Metall / Metallo
U12-U14	8	Precortado / Precut / Prédécoupé / Vorgeschnitten / Pretagliatto	Tablero / Plywood / Planche / Sperrholz / Tavola
U15	1	Preformado / Prefomed/ Préformé / Vorgeformt / Preformato	Metal / Metal / Metal / Metall / Metallo
U16	1	Precortado / Precut / Prédécoupé / Vorgeschnitten / Pretagliatto	Tablero / Plywood / Planche / Sperrholz / Tavola
U17	1	Preformado / Prefomed/ Préformé / Vorgeformt / Preformato	Latón / Brass / Latón / Messing / Ottone
U18	1	Preformado / Prefomed/ Préformé / Vorgeformt / Preformato	Metal / Metal / Metal / Metall / Metallo
U19	1	ø1,5x36	Latón / Brass / Latón / Messing / Ottone
U20	2	Preformado / Prefomed/ Préformé / Vorgeformt / Preformato	Metal / Metal / Metal / Metall / Metallo
U21	2	Preformado / Prefomed/ Préformé / Vorgeformt / Preformato	Metal / Metal / Metal / Metall / Metallo
U22	1	Preformado / Prefomed/ Préformé / Vorgeformt / Preformato	Metal / Metal / Metal / Metall / Metallo
U23	1	Preformado / Prefomed/ Préformé / Vorgeformt / Preformato	Metal / Metal / Metal / Metall / Metallo







Lista de piezas / Parts List / Liste des pièces / Teileliste / Elenco delle parti

Nº/No. / N° / Nr. No	Cantidad / Quantity / Quantité / Menge / Quantità	Medidas / Measurements / Dimensions / Maße / Misure	Material / Material / Matériau / Material / Materiale
U24	1	Precortado / Precut / Prédécoupé / Vorgeschnitten / Pretagliatto	Tablero / Plywood / Planche / Sperrholz / Tavola
U25	2	Preformado / Prefomed/ Préformé / Vorgeformt / Preformato	Metal / Metal / Metal / Metall / Metallo
U26	2	Preformado / Prefomed/ Préformé / Vorgeformt / Preformato	Metal / Metal / Metal / Metall / Metallo
U27	2	Preformado / Prefomed/ Préformé / Vorgeformt / Preformato	Metal / Metal / Metal / Metall / Metallo
U28	1	2x5x46	Tilo / Lime wood / Tilleul / Linde / Tiglio
U29	1	2x7x46	Tilo / Lime wood / Tilleul / Linde / Tiglio
U30	24	Preformado / Prefomed/ Préformé / Vorgeformt / Preformato	Latón / Brass / Latón / Messing / Ottone
U31	2	ø0,15x1000	Hilo crudo / Raw thread / Fil brut / Rohes Baumwollfaden / Filo crudo
V1-V5	10	Precortado / Precut / Prédécoupé / Vorgeschnitten / Pretagliatto	Tablero / Plywood / Planche / Sperrholz / Tavola
V6	46	1x3x150	Tilo / Lime wood / Tilleul / Linde / Tiglio
W1-W2	3	Preformado / Prefomed/ Préformé / Vorgeformt / Preformato	Latón / Brass / Latón / Messing / Ottone
W3	1	Preformado / Prefomed/ Préformé / Vorgeformt / Preformato	Latón / Brass / Latón / Messing / Ottone
W4	2	Preformado / Prefomed/ Préformé / Vorgeformt / Preformato	Latón / Brass / Latón / Messing / Ottone
W5	1	ø1,5x118	Latón / Brass / Latón / Messing / Ottone
W6	1	Preformado / Prefomed/ Préformé / Vorgeformt / Preformato	Latón / Brass / Latón / Messing / Ottone
W7	1	Preformado / Prefomed/ Préformé / Vorgeformt / Preformato	Metal / Metal / Metal / Metall / Metallo
W8	1	ø1,5x138	Latón / Brass / Latón / Messing / Ottone
W9	1	Preformado / Prefomed/ Préformé / Vorgeformt / Preformato	Latón / Brass / Latón / Messing / Ottone
X1-X12	12	Precortado / Precut / Prédécoupé / Vorgeschnitten / Pretagliatto	Tablero / Plywood / Planche / Sperrholz / Tavola
X13-X20	8	Precortado / Precut / Prédécoupé / Vorgeschnitten / Pretagliatto	Tablero / Plywood / Planche / Sperrholz / Tavola
X21-X22	2	Precortado / Precut / Prédécoupé / Vorgeschnitten / Pretagliatto	Tablero / Plywood / Planche / Sperrholz / Tavola
X23	4	Precortado / Precut / Prédécoupé / Vorgeschnitten / Pretagliatto	Tablero / Plywood / Planche / Sperrholz / Tavola
X24	2	Precortado / Precut / Prédécoupé / Vorgeschnitten / Pretagliatto	Tablero / Plywood / Planche / Sperrholz / Tavola
X25	24	1x3x140	Tilo / Lime wood / Tilleul / Linde / Tiglio
X26	1	Precortado / Precut / Prédécoupé / Vorgeschnitten / Pretagliatto	Tablero / Plywood / Planche / Sperrholz / Tavola
X27	1	Precortado / Precut / Prédécoupé / Vorgeschnitten / Pretagliatto	Tablero / Plywood / Planche / Sperrholz / Tavola
X28	1	2x2x68	Tilo / Lime wood / Tilleul / Linde / Tiglio
X29	1	2x2x93	Tilo / Lime wood / Tilleul / Linde / Tiglio
X30	1	2x2x22	Tilo / Lime wood / Tilleul / Linde / Tiglio
X31	1	2x2x18	Tilo / Lime wood / Tilleul / Linde / Tiglio
X32	1	Precortado / Precut / Prédécoupé / Vorgeschnitten / Pretagliatto	Tablero / Plywood / Planche / Sperrholz / Tavola
X33	1	Precortado / Precut / Prédécoupé / Vorgeschnitten / Pretagliatto	Tablero / Plywood / Planche / Sperrholz / Tavola
X34	1	Preformado / Prefomed/ Préformé / Vorgeformt / Preformato	Tela / Cloth / Étoffe / Stoff / Tela
Y1-Y3	4	Precortado / Precut / Prédécoupé / Vorgeschnitten / Pretagliatto	Tablero / Plywood / Planche / Sperrholz / Tavola
Y4	6	2x5x90	Tilo / Lime wood / Tilleul / Linde / Tiglio
Y5	8	Preformado / Prefomed/ Préformé / Vorgeformt / Preformato	Latón / Brass / Latón / Messing / Ottone
Y6	2	1x3x91	Tilo / Lime wood / Tilleul / Linde / Tiglio
Y7	2	1x3x35	Tilo / Lime wood / Tilleul / Linde / Tiglio
Y8	2	Preformado / Prefomed/ Préformé / Vorgeformt / Preformato	Metal / Metal / Metal / Metall / Metallo
Y9	1	Preformado / Prefomed/ Préformé / Vorgeformt / Preformato	Metal / Metal / Metal / Metall / Metallo
Y10	1	Preformado / Prefomed/ Préformé / Vorgeformt / Preformato	Metal / Metal / Metal / Metall / Metallo
Y11	4	2x5x38	Tilo / Lime wood / Tilleul / Linde / Tiglio
Y12	2	2x5x27	Tilo / Lime wood / Tilleul / Linde / Tiglio
Y13-Y14	2	Precortado / Precut / Prédécoupé / Vorgeschnitten / Pretagliatto	Tablero / Plywood / Planche / Sperrholz / Tavola
Y15	1	ø0,15x1000	Hilo crudo / Raw thread / Fil brut / Rohes Baumwollfaden / Filo crudo

Lista de piezas / Parts List / Liste des pièces / Teileliste / Elenco delle parti

Nº/No./ N° / Nr. No	Cantidad / Quantity / Quantité / Menge / Quantità	Medidas / Measurements / Dimensions / Maße / Misure	Material / Material / Matériau / Material / Materiale
Y16	2	ø0,15x800	Hilo crudo / Raw thread / Fil brut / Rohes Baumwollfaden / Filo crudo
Z1	1	1x3x29	Tilo / Lime wood / Tilleul / Linde / Tiglio
Z2	5	ø0,15x1000	Hilo crudo / Raw thread / Fil brut / Rohes Baumwollfaden / Filo crudo
Z3	3	Preformado / Prefomed/ Préformé / Vorgeformt / Preformato	Metal / Metal / Metal / Metall / Metallo
Z4	2	Preformado / Prefomed/ Préformé / Vorgeformt / Preformato	Metal / Metal / Metal / Metall / Metallo
Z5	1	Preformado / Prefomed/ Préformé / Vorgeformt / Preformato	Metal / Metal / Metal / Metall / Metallo
Z6	1	Preformado / Prefomed/ Préformé / Vorgeformt / Preformato	Metal / Metal / Metal / Metall / Metallo
Z7	1	Preformado / Prefomed/ Préformé / Vorgeformt / Preformato	Metal / Metal / Metal / Metall / Metallo
Z8	1	Preformado / Prefomed/ Préformé / Vorgeformt / Preformato	Metal / Metal / Metal / Metall / Metallo
Z9	2	Preformado / Prefomed/ Préformé / Vorgeformt / Preformato	Metal / Metal / Metal / Metall / Metallo
Z10	3	Preformado / Prefomed/ Préformé / Vorgeformt / Preformato	Metal / Metal / Metal / Metall / Metallo
Z11	5	Preformado / Prefomed/ Préformé / Vorgeformt / Preformato	Metal / Metal / Metal / Metall / Metallo
Z12-Z13	2	Preformado / Prefomed/ Préformé / Vorgeformt / Preformato	Latón / Brass / Latón / Messing / Ottone
Z14	2	Preformado / Prefomed/ Préformé / Vorgeformt / Preformato	Metal / Metal / Metal / Metall / Metallo
Z15	2	Preformado / Prefomed/ Préformé / Vorgeformt / Preformato	Latón / Brass / Latón / Messing / Ottone
Z16	1	Preformado / Prefomed/ Préformé / Vorgeformt / Preformato	Metal / Metal / Metal / Metall / Metallo
Z17	1	Preformado / Prefomed/ Préformé / Vorgeformt / Preformato	Metal / Metal / Metal / Metall / Metallo
Z18	6	Preformado / Prefomed/ Préformé / Vorgeformt / Preformato	Metal / Metal / Metal / Metall / Metallo
Z19	1	Preformado / Prefomed/ Préformé / Vorgeformt / Preformato	Metal / Metal / Metal / Metall / Metallo
Z20	2	ø1x15	Latón / Brass / Latón / Messing / Ottone
Z21	6	ø0,50x200	Hilo marrón / Brown thread / Fil brun /braunes Baumwollfaden / Filo marrone
Z22	1	2x2x10	Tilo / Lime wood / Tilleul / Linde / Tiglio
Z23	2	Preformado / Prefomed/ Préformé / Vorgeformt / Preformato	Metal / Metal / Metal / Metall / Metallo
Z24	2	ø0,50x50	Latón / Brass / Latón / Messing / Ottone
Z25	3	ø0,80x1000	Hilo crudo / Raw thread / Fil brut / Rohes Baumwollfaden / Filo crudo
Z26	1	ø0,80x700	Hilo crudo / Raw thread / Fil brut / Rohes Baumwollfaden / Filo crudo
Z27	1	Preformado / Prefomed/ Préformé / Vorgeformt / Preformato	Metal / Metal / Metal / Metall / Metallo
Z28	1	Preformado / Prefomed/ Préformé / Vorgeformt / Preformato	Metal / Metal / Metal / Metall / Metallo
Z29	2	ø1x100	Latón / Brass / Latón / Messing / Ottone
Z30	2	1,5x165	Latón / Brass / Latón / Messing / Ottone
Z31	2	2x5x103	Tilo / Lime wood / Tilleul / Linde / Tiglio
Z32	4	2x5x8	Tilo / Lime wood / Tilleul / Linde / Tiglio
Z33	8	ø0,80x1000	Hilo crudo / Raw thread / Fil brut / Rohes Baumwollfaden / Filo crudo
Z34	10	Preformado / Prefomed/ Préformé / Vorgeformt / Preformato	Metal / Metal / Metal / Metall / Metallo
Z35	2	1,5x200	Latón / Brass / Latón / Messing / Ottone
Z36	1	ø0,15x200	Hilo crudo / Raw thread / Fil brut / Rohes Baumwollfaden / Filo crudo
Z37	1	ø6x285	Tilo / Lime wood / Tilleul / Linde / Tiglio
Z38	1	Preformado / Prefomed/ Préformé / Vorgeformt / Preformato	Latón / Brass / Latón / Messing / Ottone
Z39	1	Preformado / Prefomed/ Préformé / Vorgeformt / Preformato	Latón / Brass / Latón / Messing / Ottone
Z40	5	ø1x10	Latón / Brass / Latón / Messing / Ottone
Z41	3	Preformado / Prefomed/ Préformé / Vorgeformt / Preformato	Cristal / Glass / Verre / Glas / Cristallo
Z42	1	ø3x60	Tilo / Lime wood / Tilleul / Linde / Tiglio
Z43	6	ø0,50x15	Latón / Brass / Latón / Messing / Ottone
Z44	6	Preformado / Prefomed/ Préformé / Vorgeformt / Preformato	Latón / Brass / Latón / Messing / Ottone
Z45	1	ø1x6	Latón / Brass / Latón / Messing / Ottone

<i>Lista de piezas / Parts List / Liste des pièces / Teileliste / Elenco delle parti</i>			
Nº/No./ N° / Nr. No	Cantidad / Quantity / Quantité / Menge / Quantità	Medidas / Measurements / Dimensions / Maße / Misure	Material / Material / Matériau / Material / Materiale
Z46	2	ø0,5x17	Latón / Brass / Latón / Messing / Ottone
Z47	2	ø0,5x25	Latón / Brass / Latón / Messing / Ottone
Z48	2	ø0,5x65	Latón / Brass / Latón / Messing / Ottone
Z49	1	Preformado / Prefomed/ Préformé / Vorgeformt / Preformato	Latón / Brass / Latón / Messing / Ottone
Z50	1	ø3x75	Tilo / Lime wood / Tilleul / Linde / Tiglio
Z51	1	Precortado / Precut / Prédécoupé / Vorgeschnitten / Pretagliatto	Tablero / Plywood / Planche / Sperrholz / Tavola
Z52	1	ø1,5x60	Latón / Brass / Latón / Messing / Ottone
Z53	2	Preformado / Prefomed/ Préformé / Vorgeformt / Preformato	Latón / Brass / Latón / Messing / Ottone
Z54-Z56	4	Precortado / Precut / Prédécoupé / Vorgeschnitten/ Pretagliatto	Tablero / Plywood / Planche / Sperrholz / Tavola
Z57	1	Preformado / Prefomed/ Préformé / Vorgeformt / Preformato	Metal / Metal / Metal / Metall / Metallo

<i>Lista de piezas / Parts List / Liste des pièces / Teileliste / Elenco delle parti</i>				
Nº/No./ N° / Nr. No	Descripción / Description /Description / Beschreibung / Descrizione	Cantidad / Quantity / Quantité / Menge / Quantità	Medidas / Measurements / Dimensions / Maße / Misure	Material / Material / Matériau / Material / Materiale
A		1000	10	Metal / Metal / Metal / Metall / Metallo
B		60	15	Latón / Brass / Latón / Messing / Ottone
C		17	ø0,15x100	Hilo crudo / Raw thread / Fil brut / Rohes Baumwollfaden / Filo crudo
D		7	4	Madera / Wood / Bois / Holz / Legno
J		6	10	Madera / Wood / Bois / Holz / Legno
Z41		3	ø3	Cristal / Glass / Verre / Glas / Cristallo



Accede a vídeos tutoriales fotografiando los códigos QR.
Access tutorial videos photographing QR codes.
Accédez aux didacticiels vidéo photographiant les codes QR.
Greifen Sie auf Video-Tutorials zu, die QR-Code fotografieren.
Accedi ai video tutorial fotografando i codici QR.
Доступ к видеоурокам фотографирования QR-кодов.

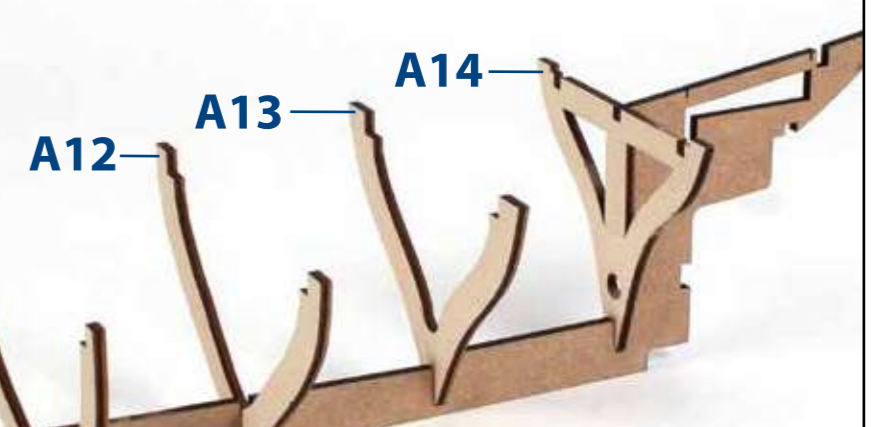
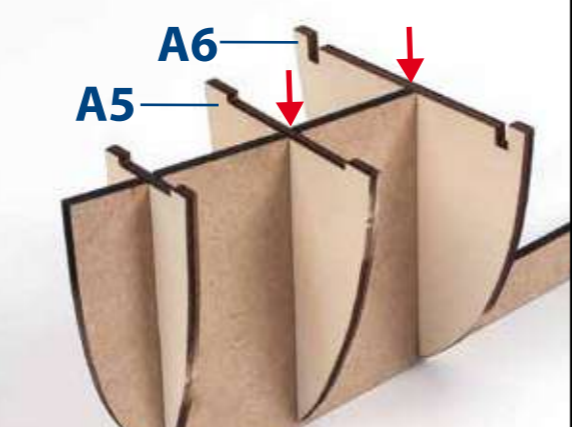
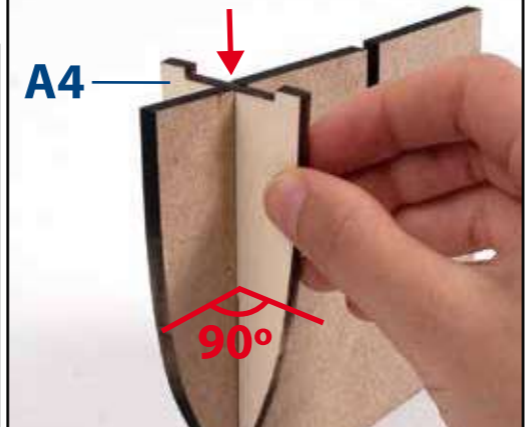
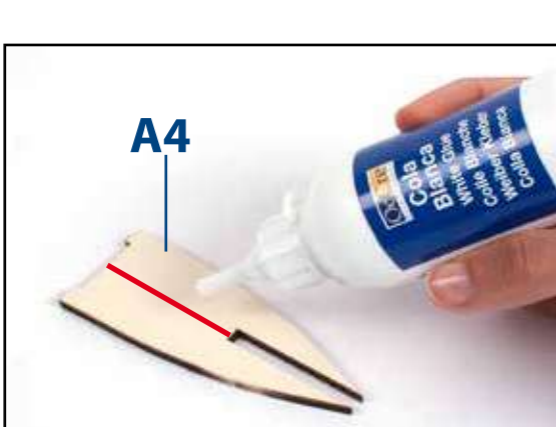
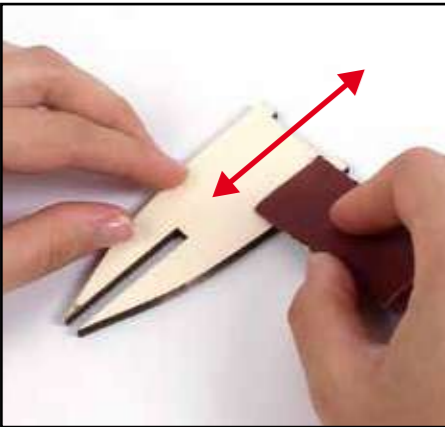
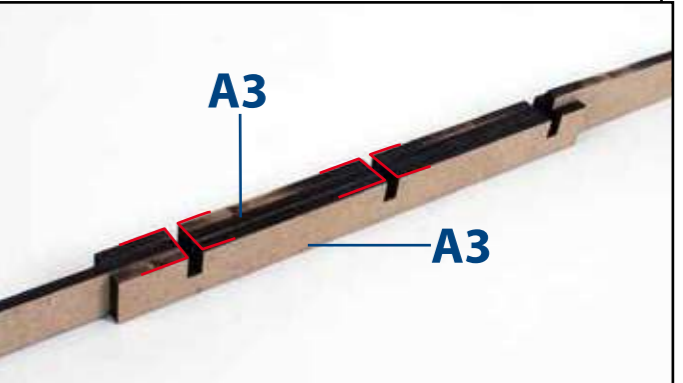
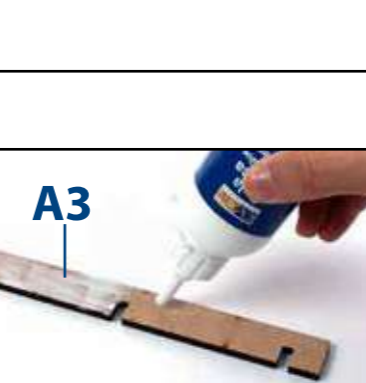
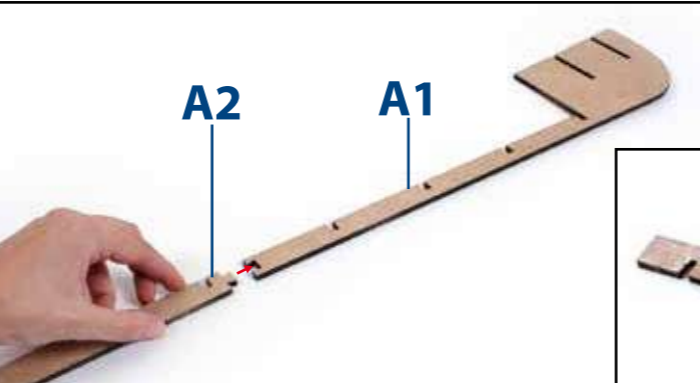
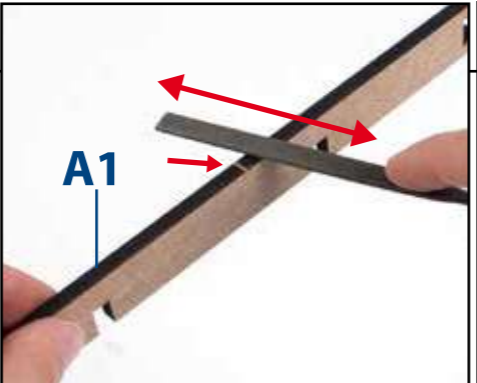
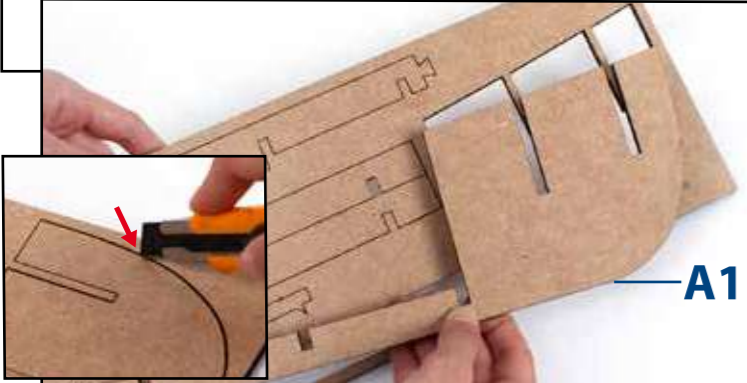
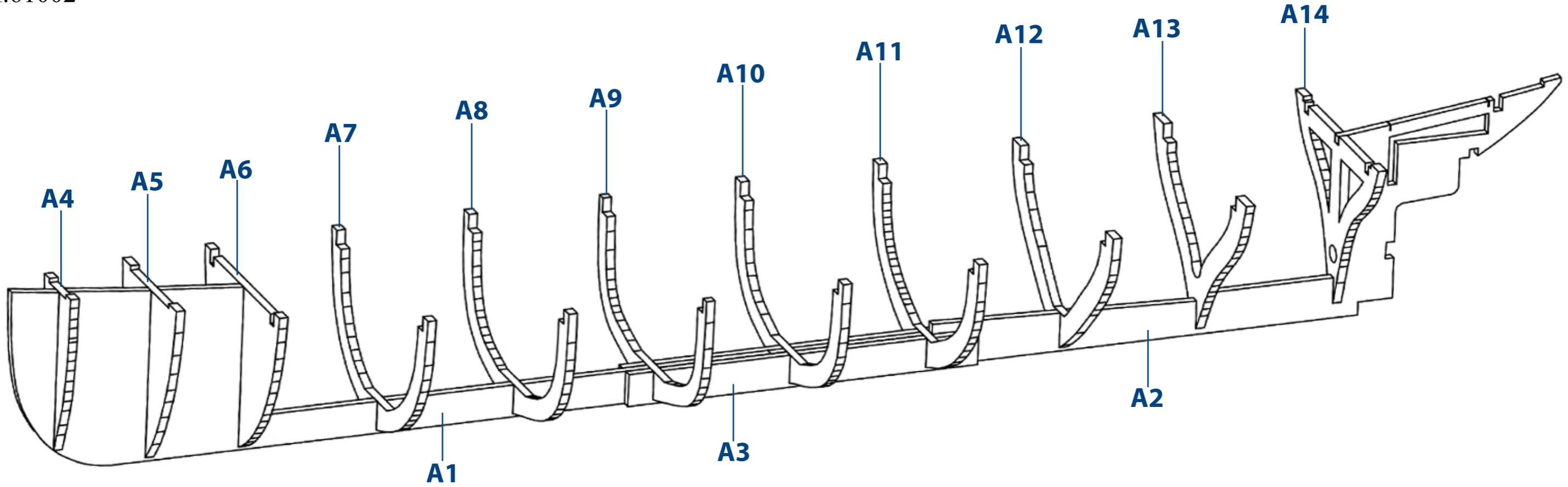
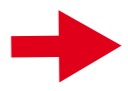

B

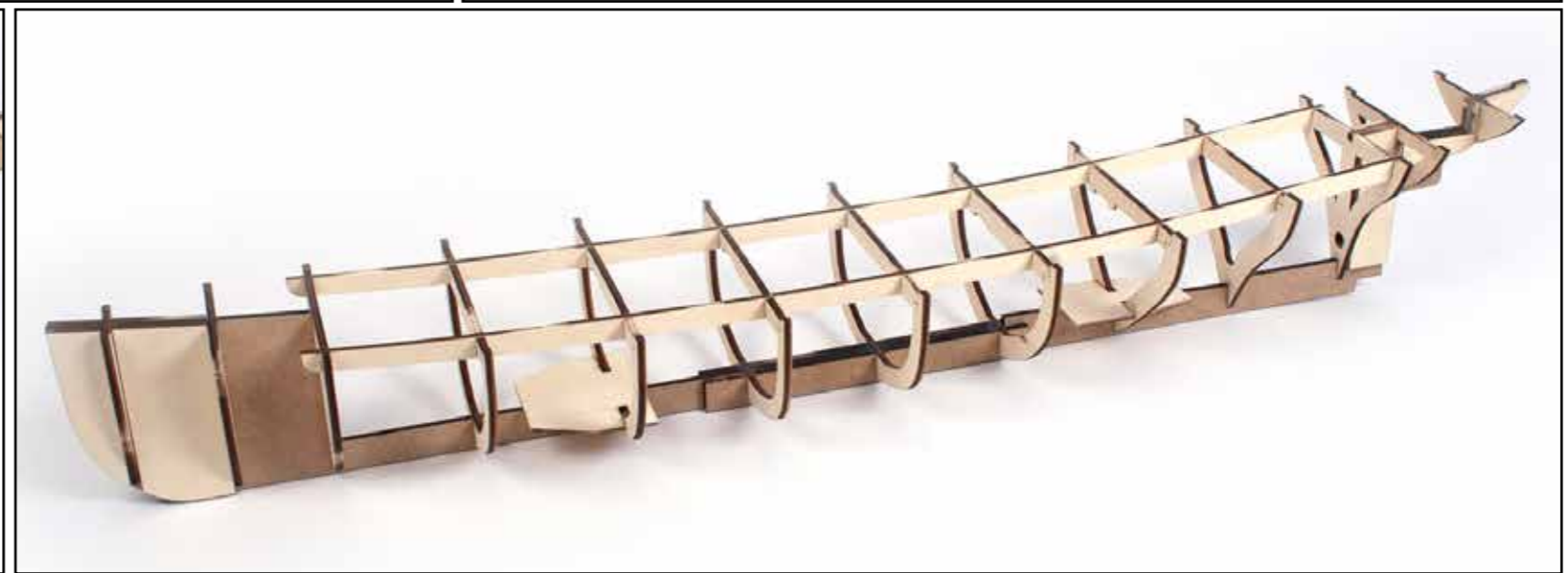
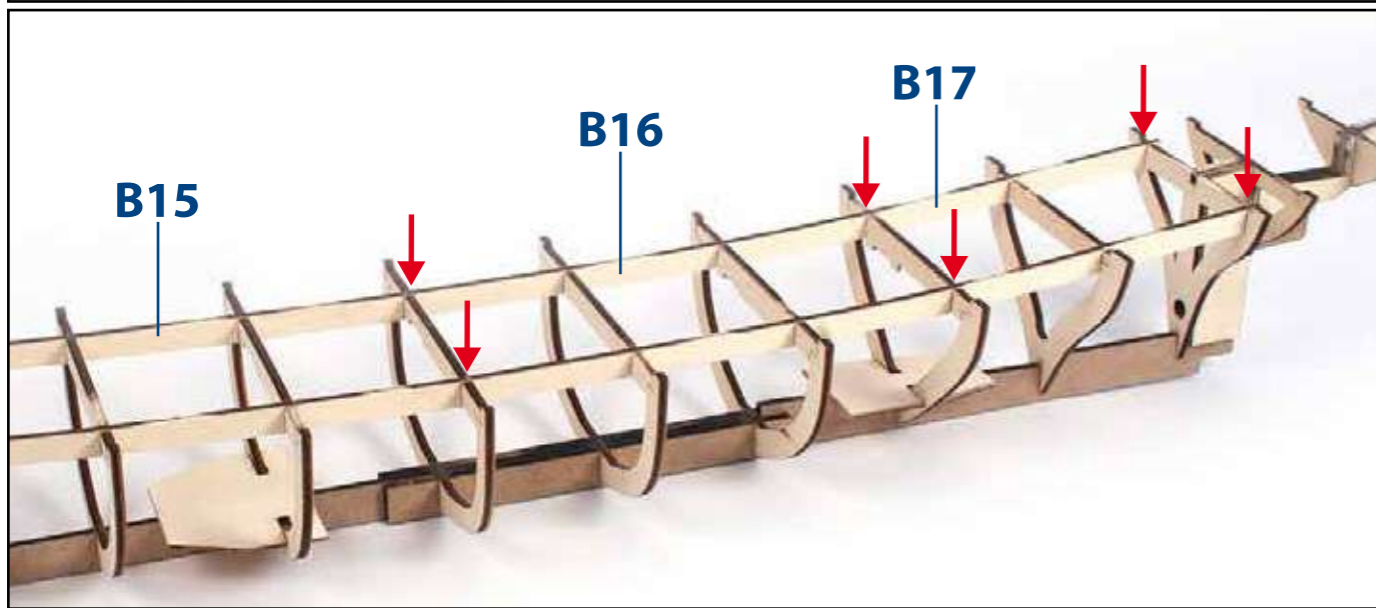
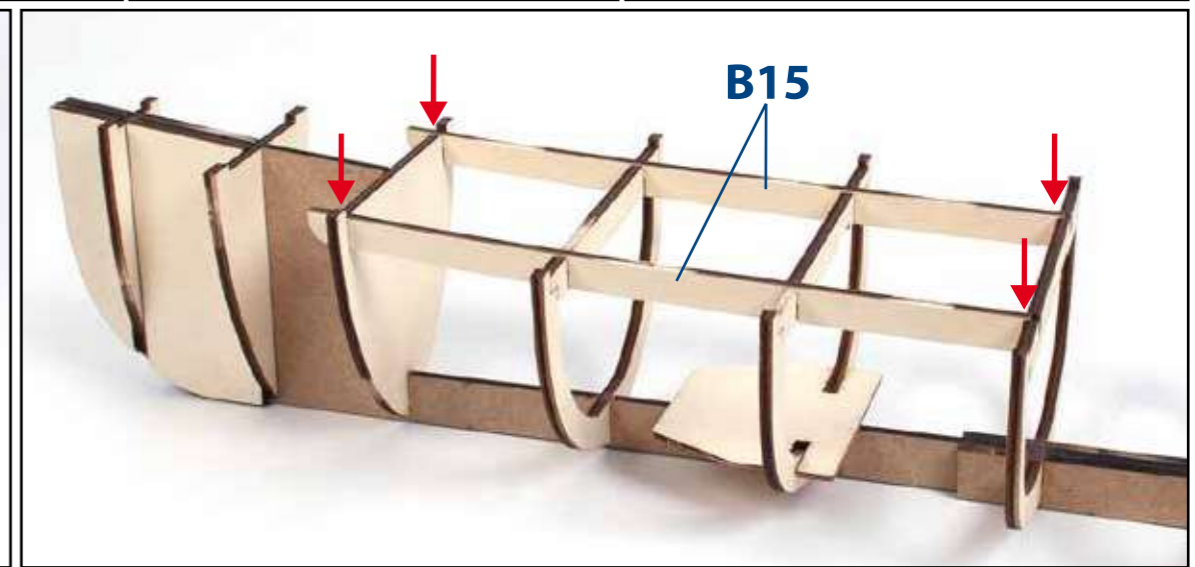
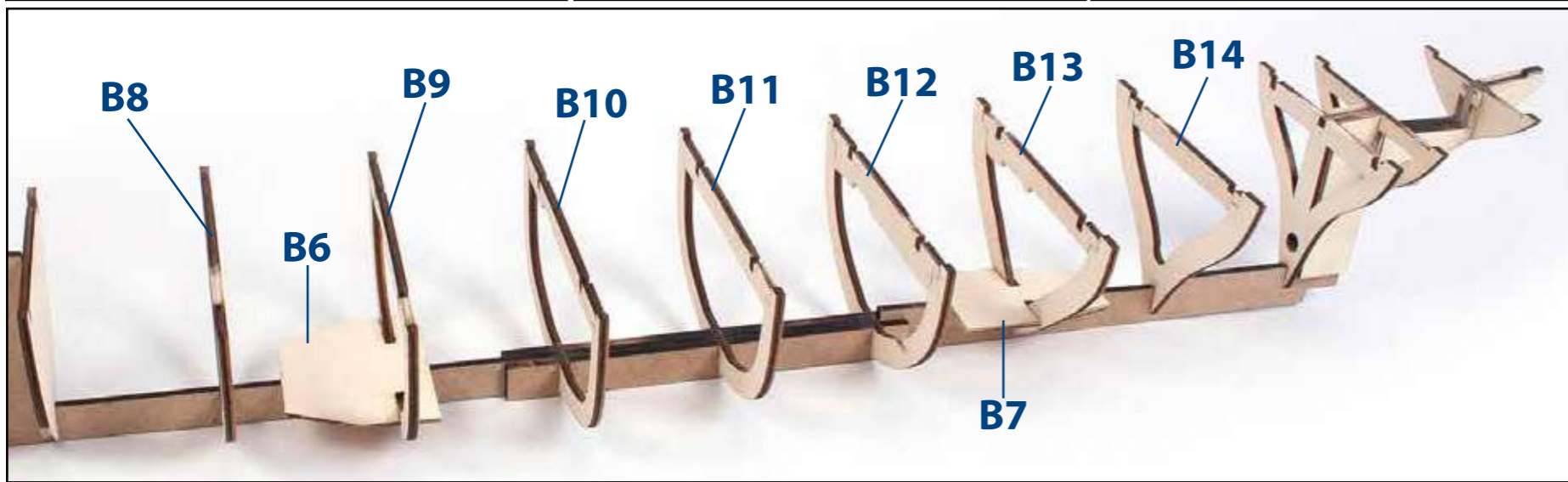
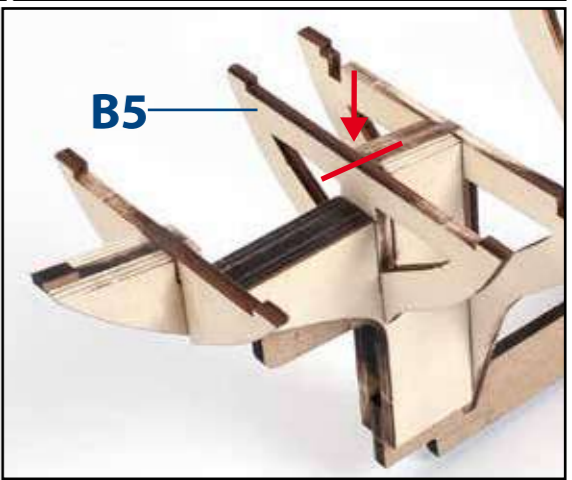
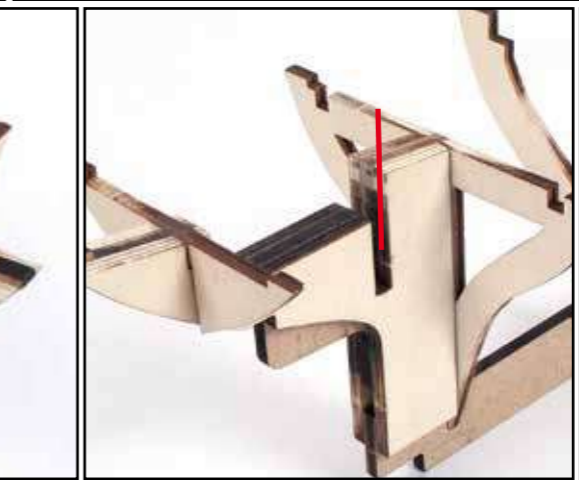
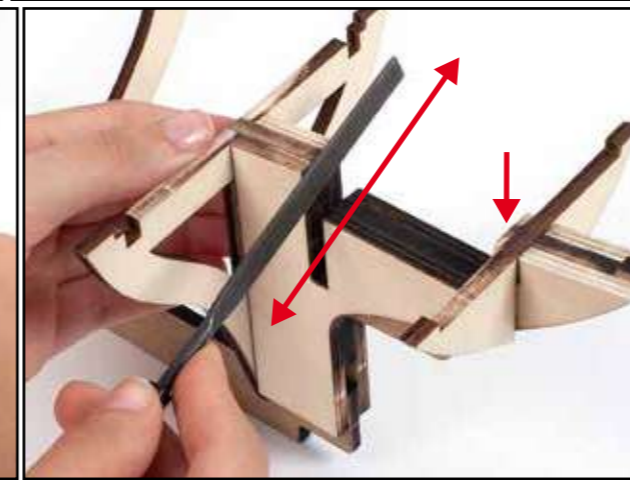
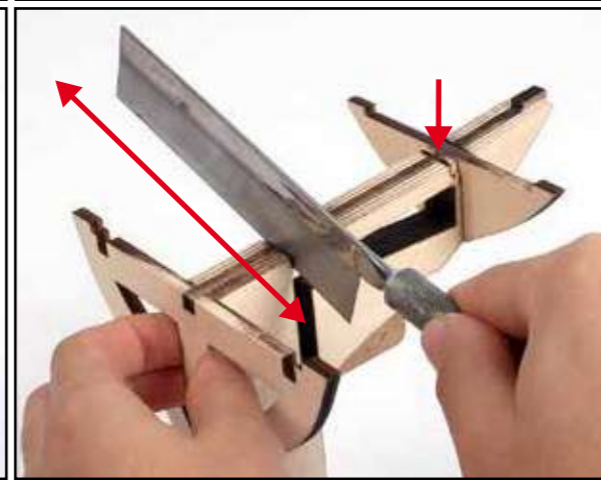
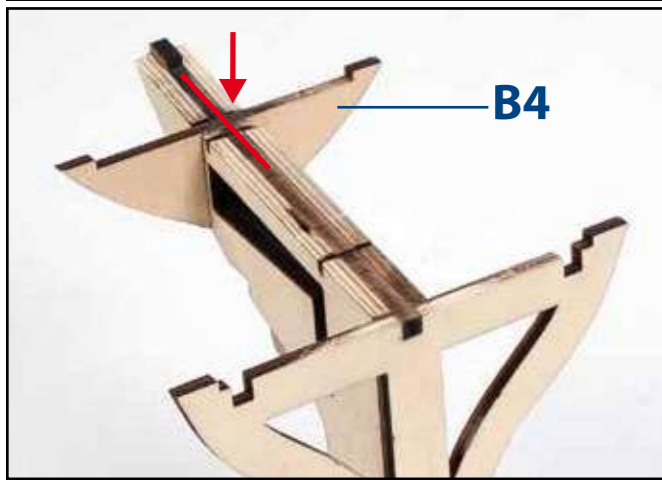
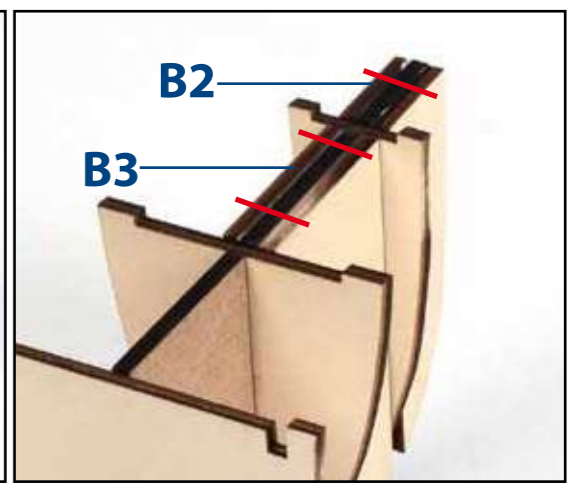
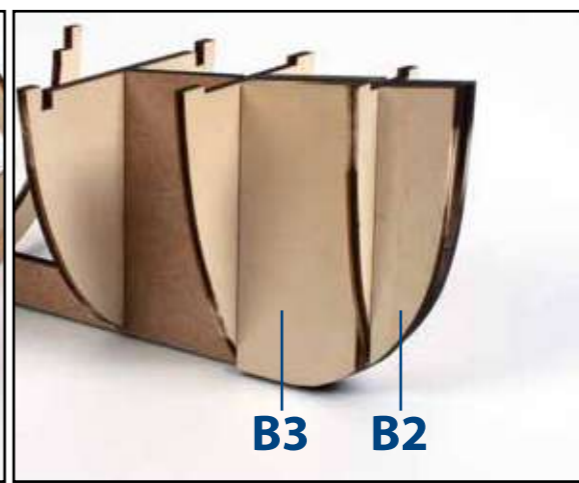
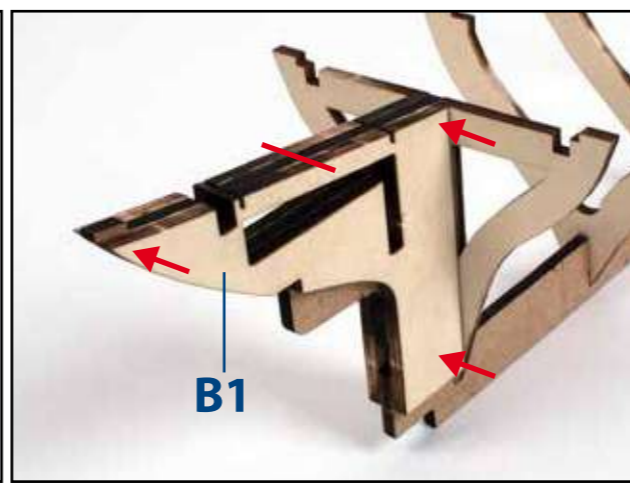
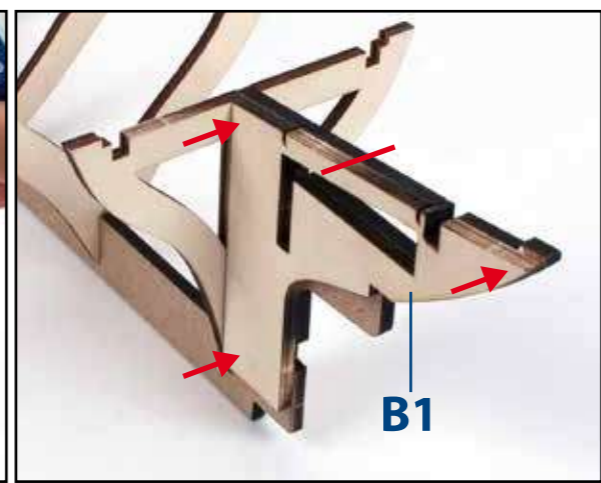

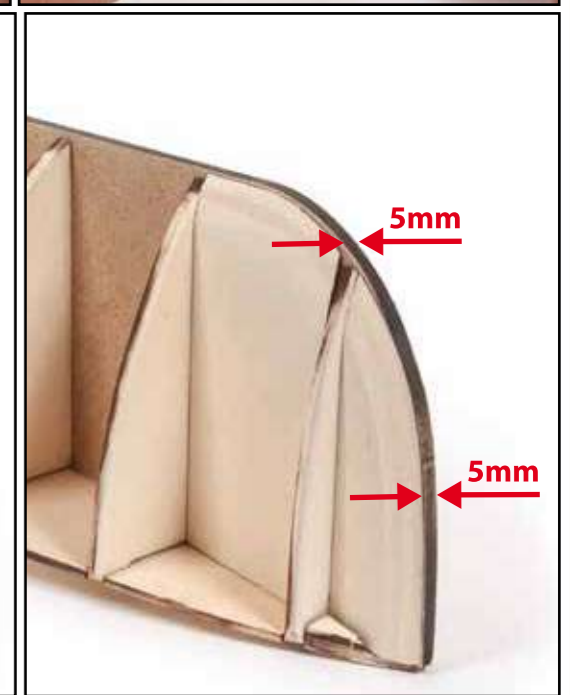
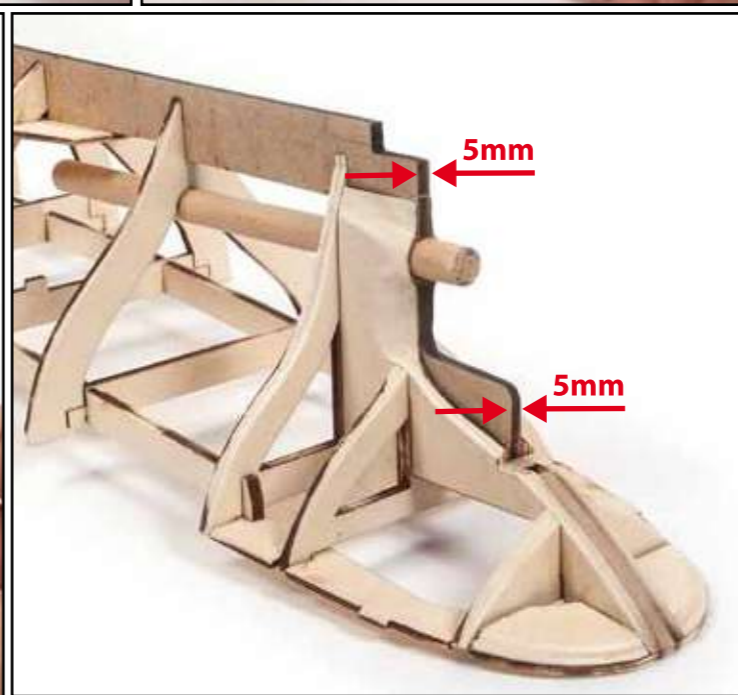
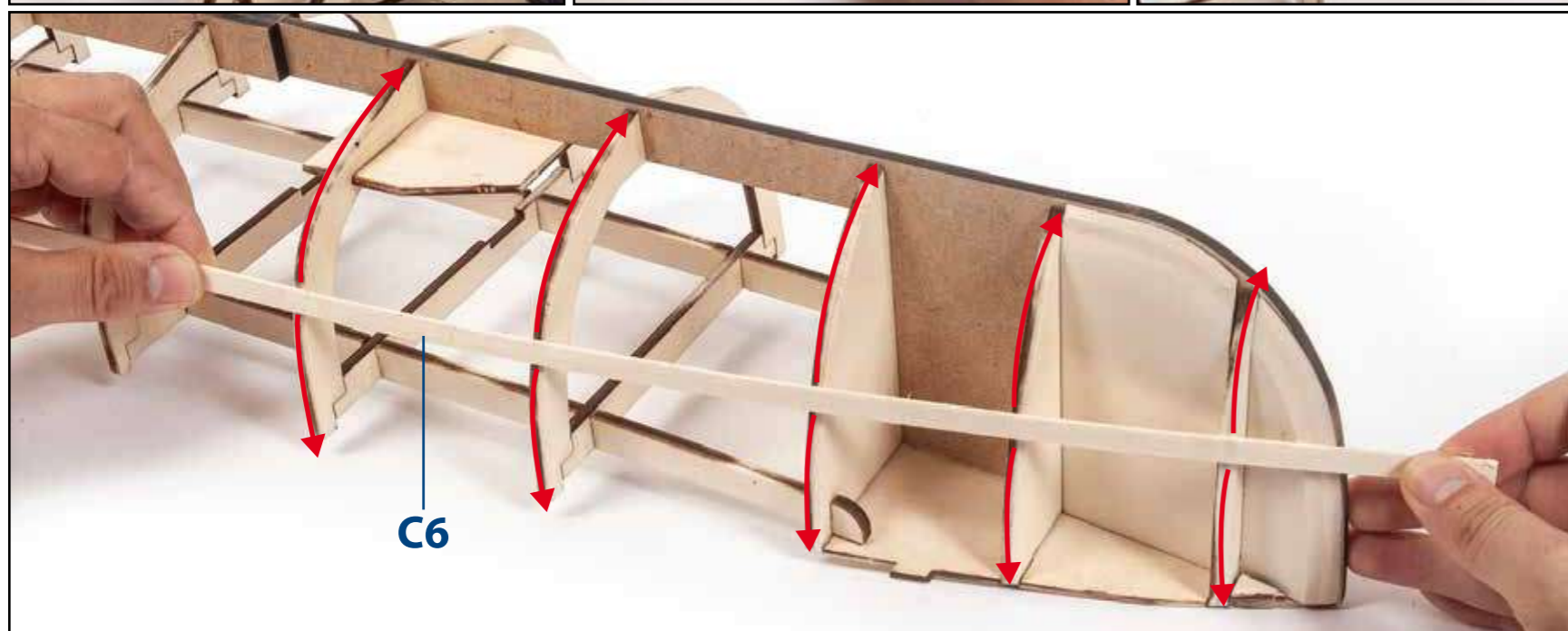
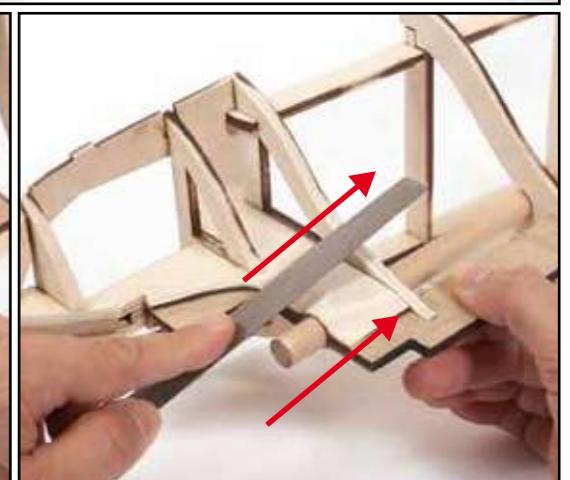
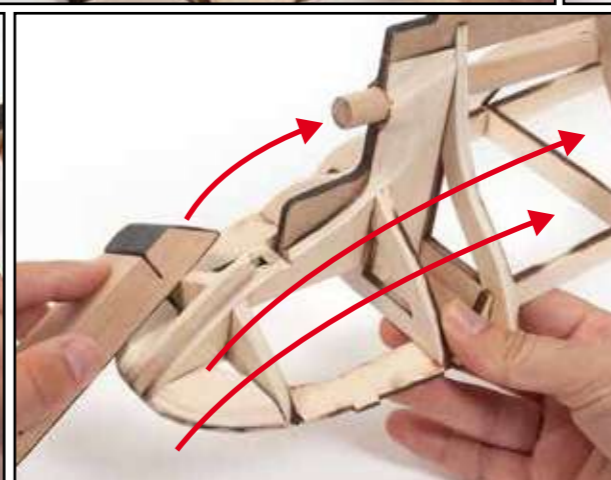
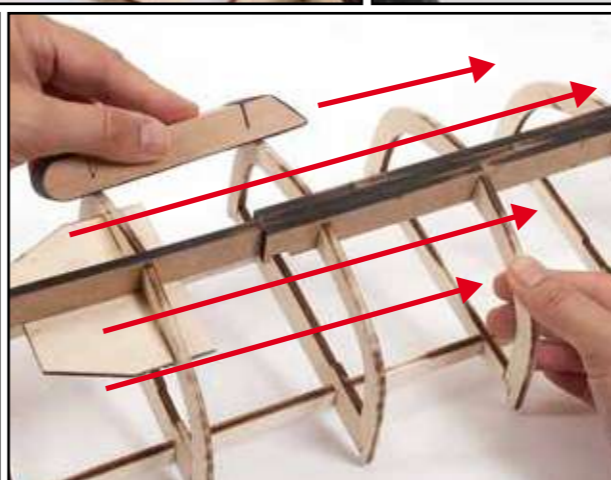
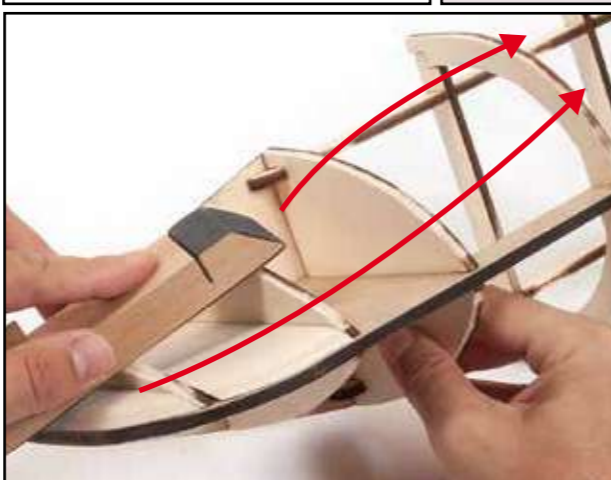
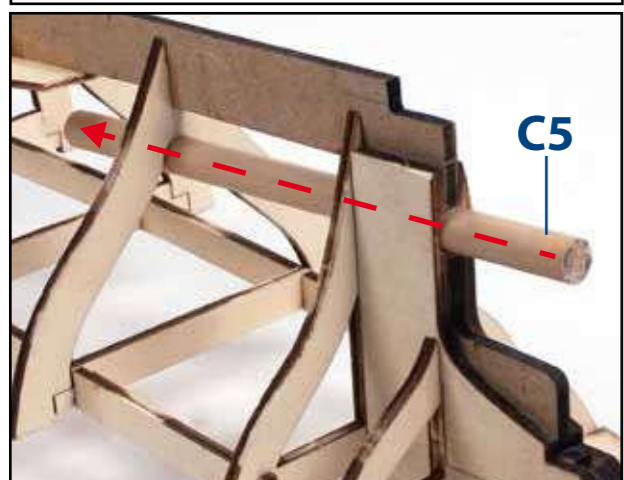
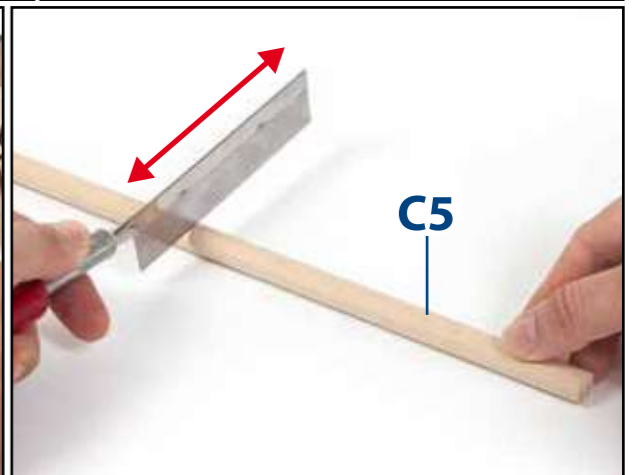
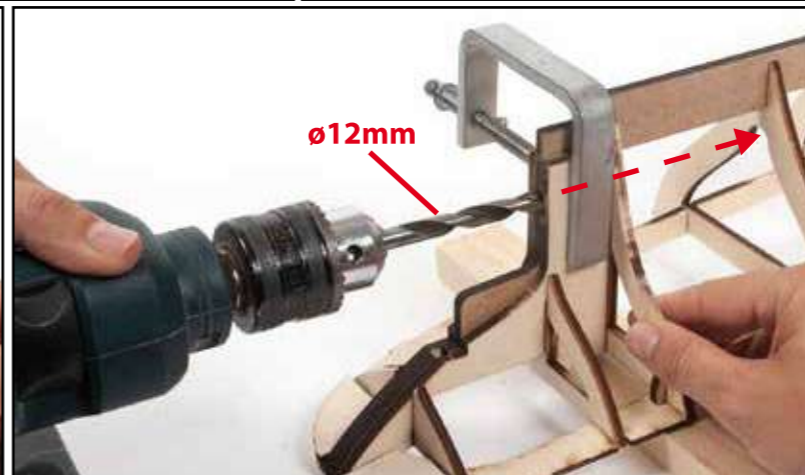
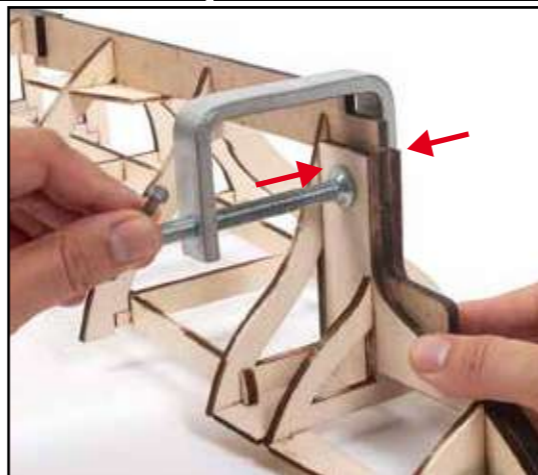
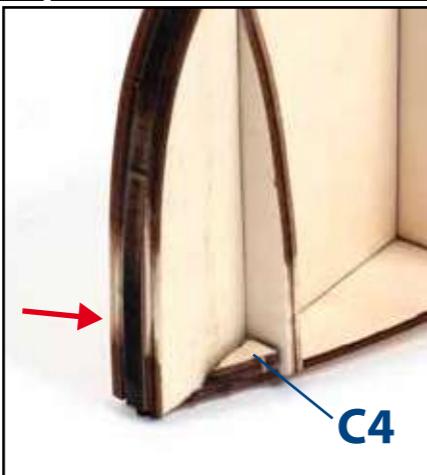
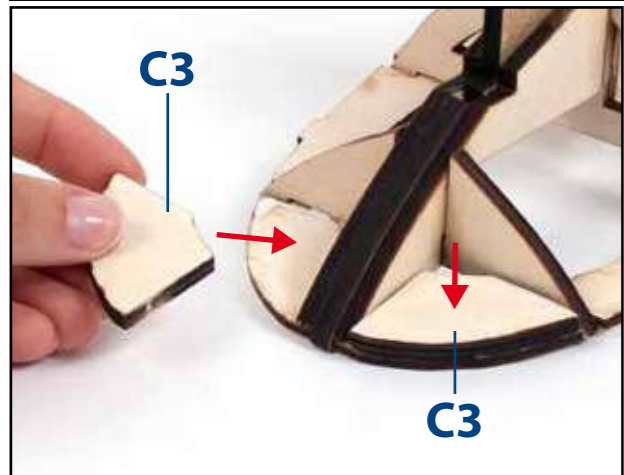
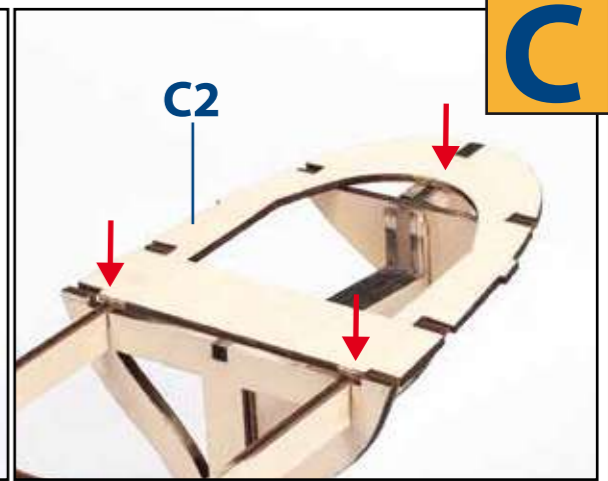
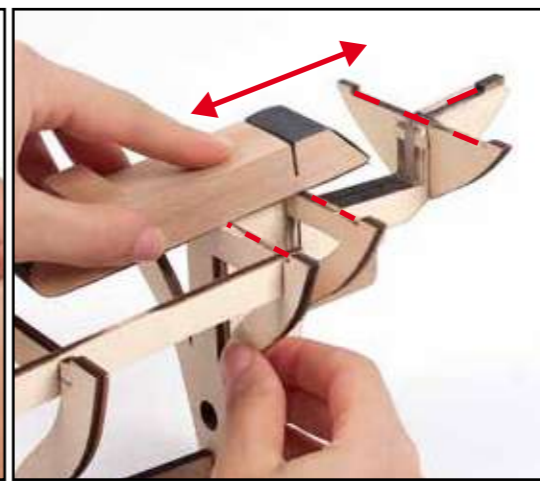
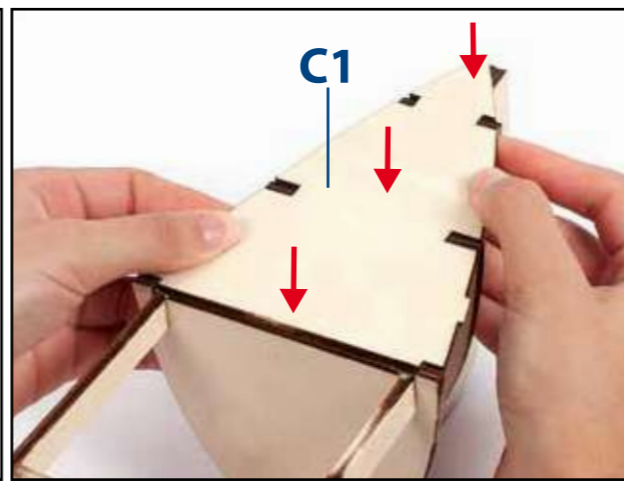
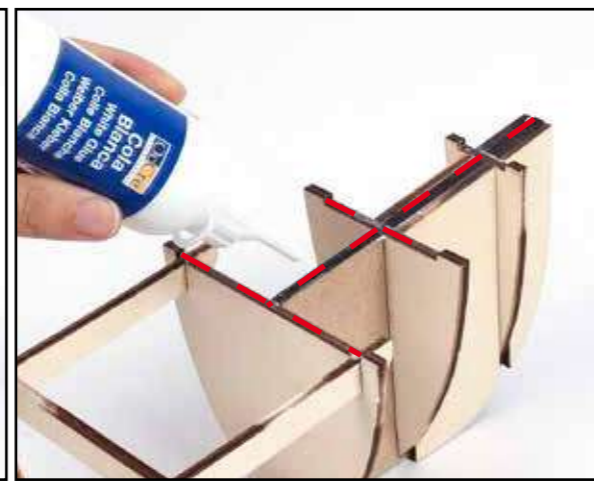
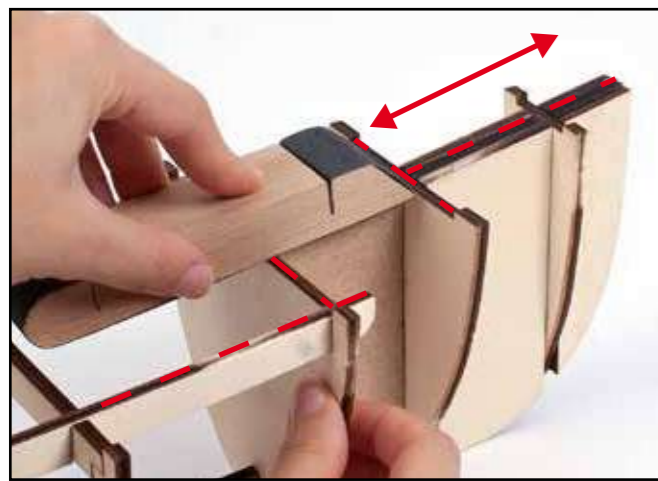

D

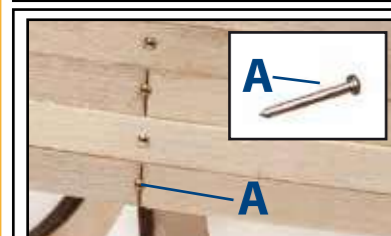
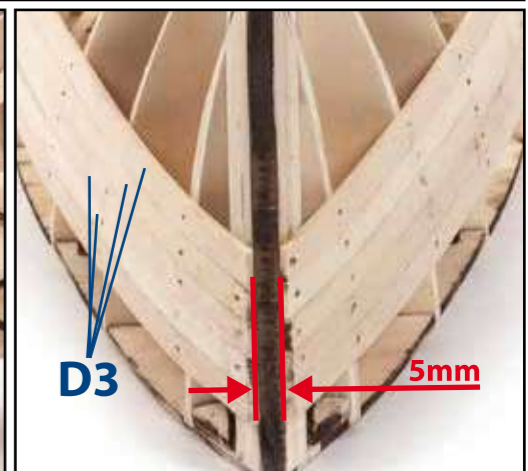
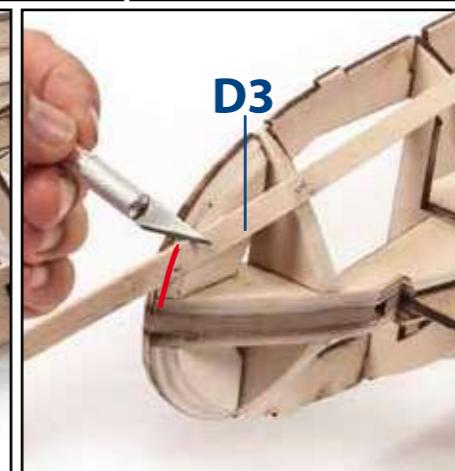
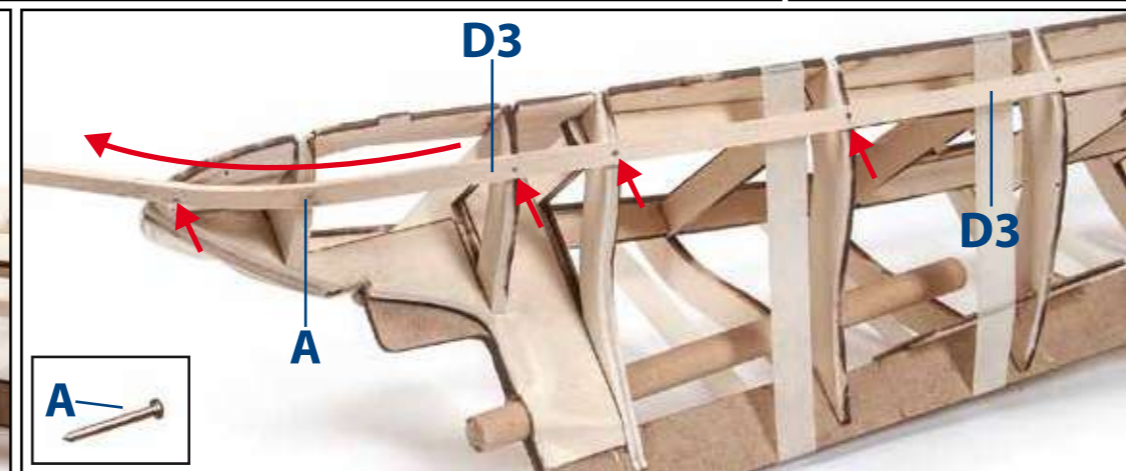
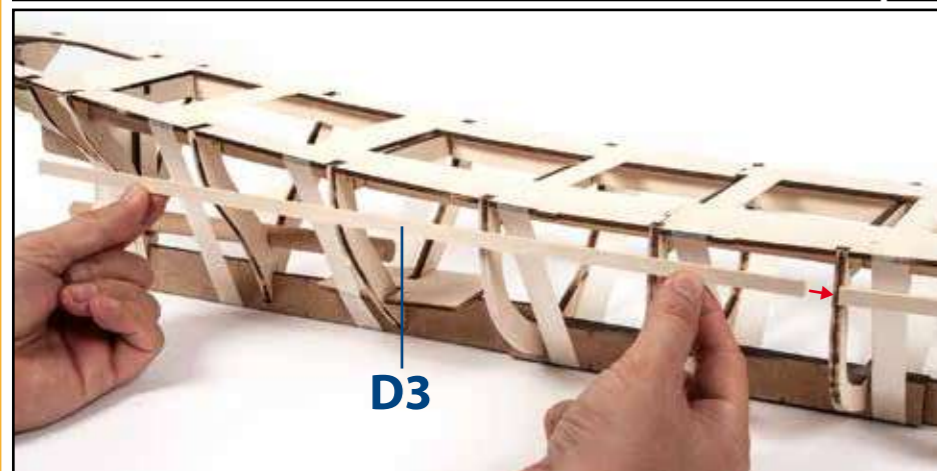
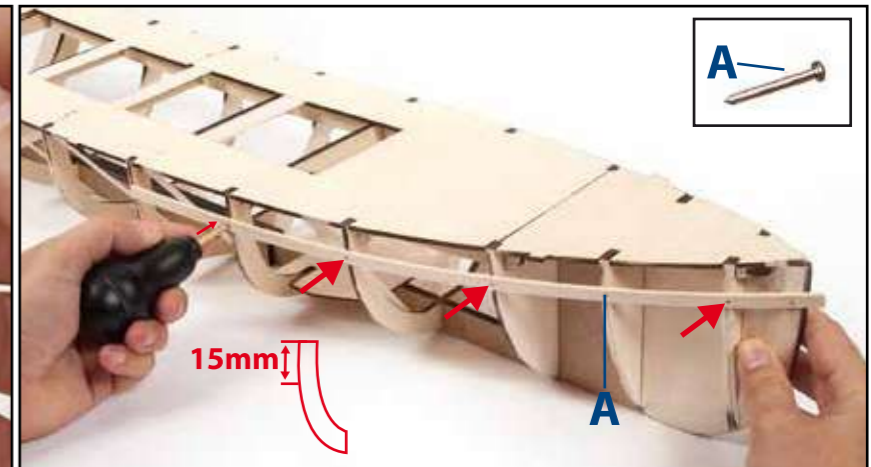
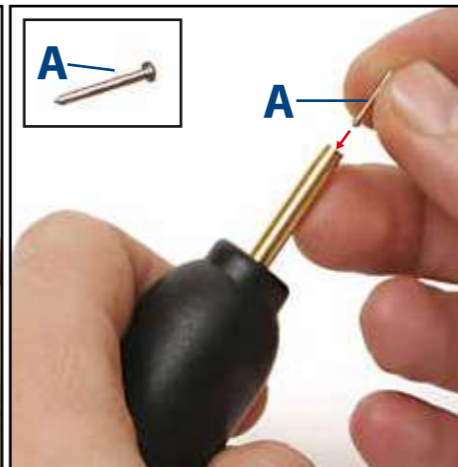
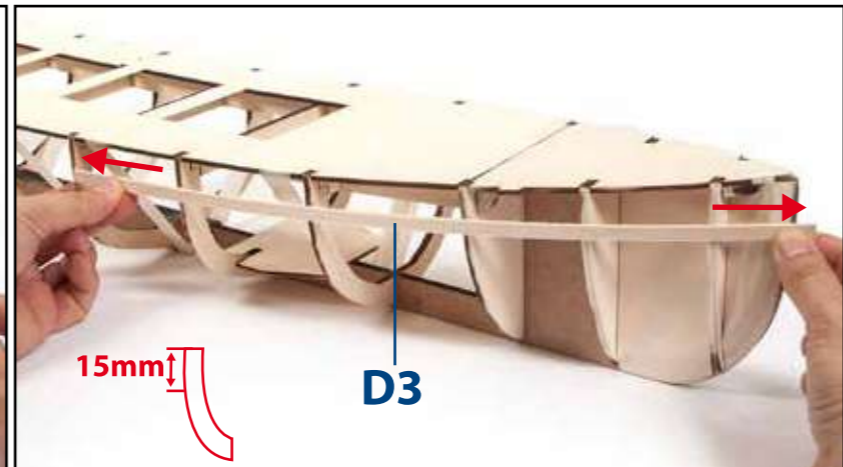
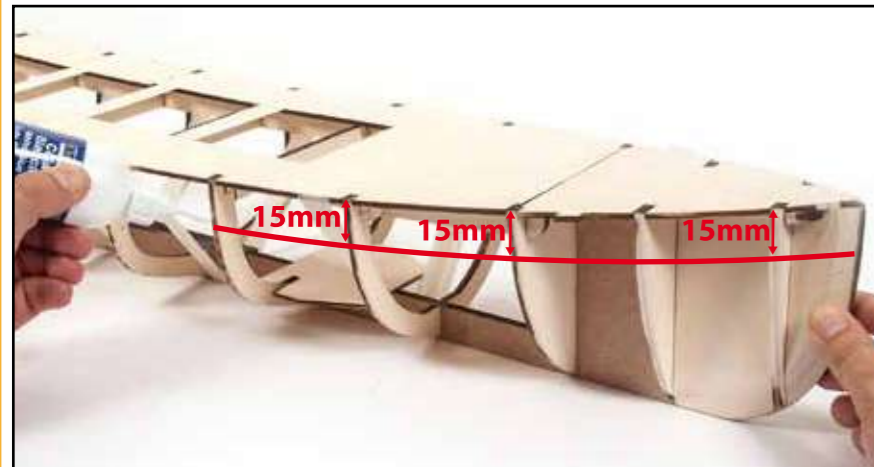
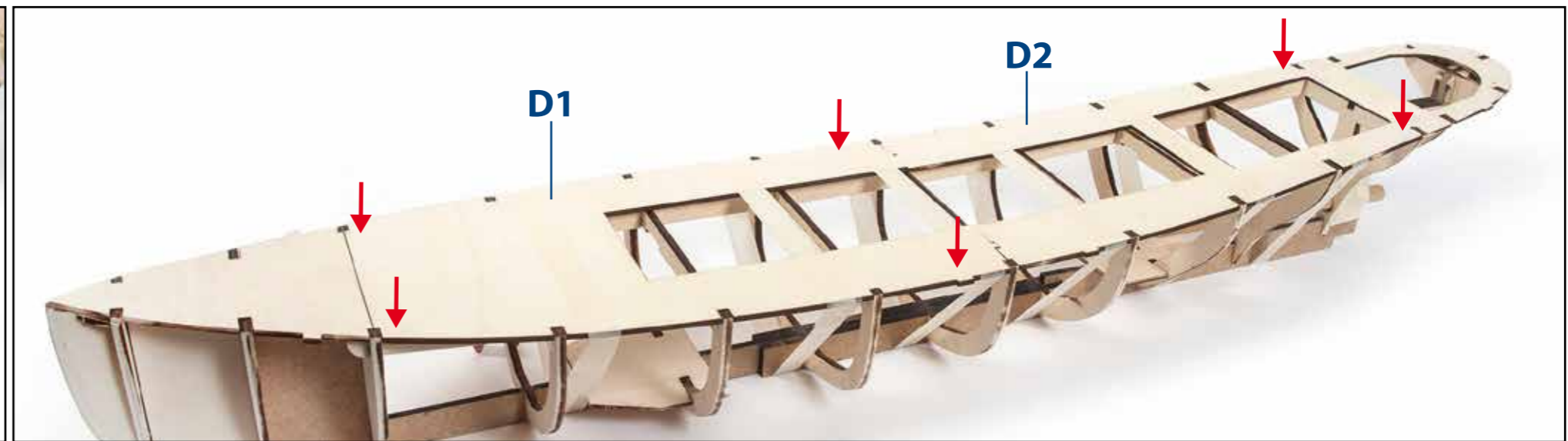
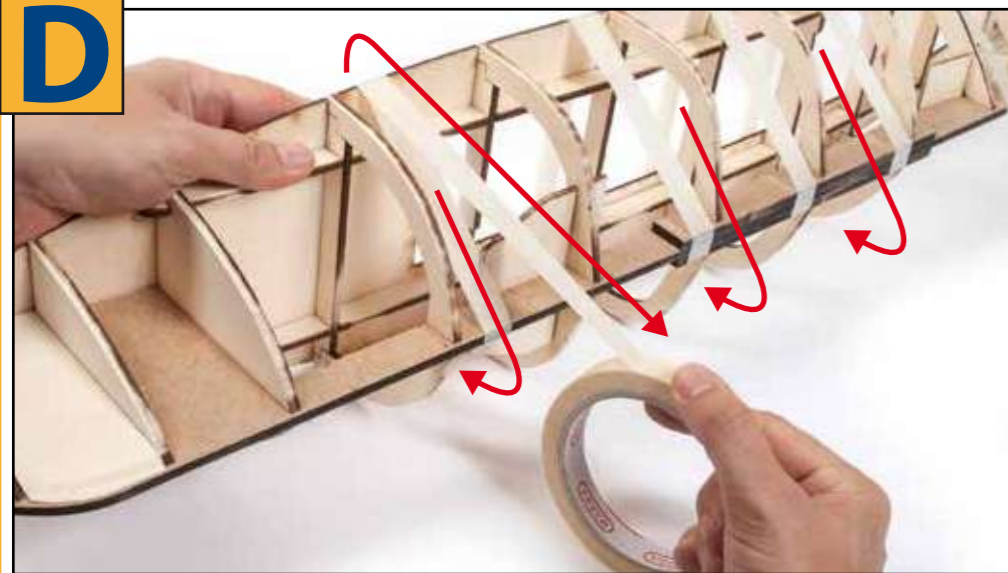

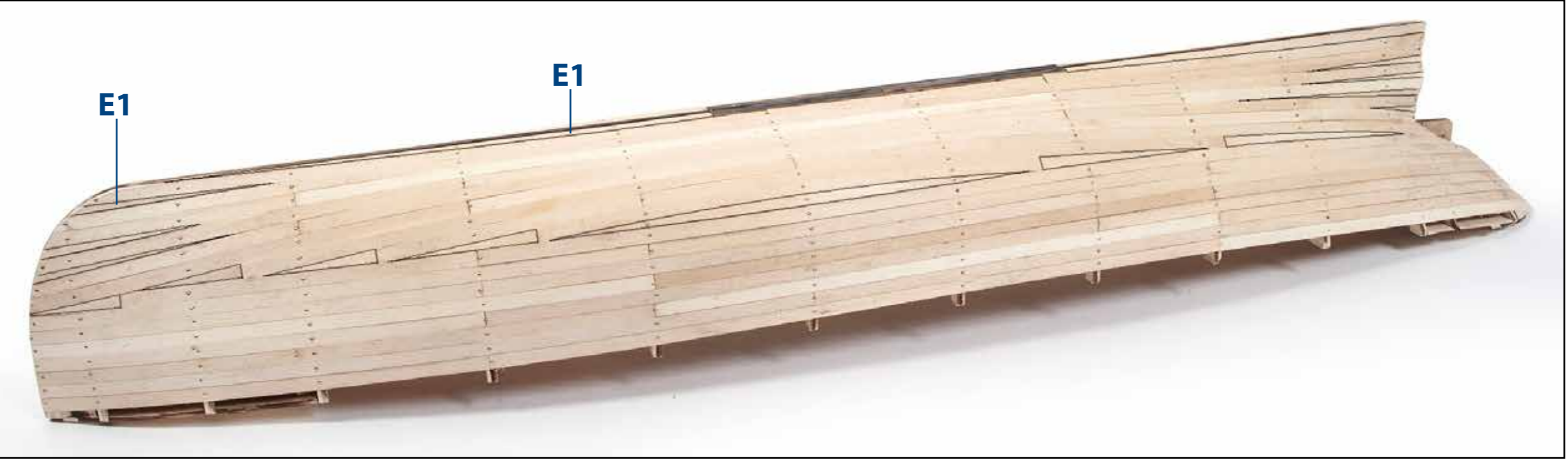
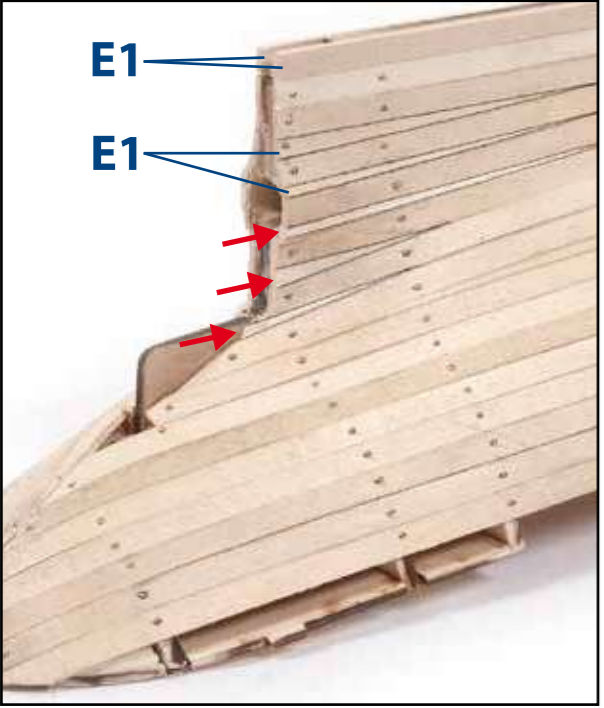
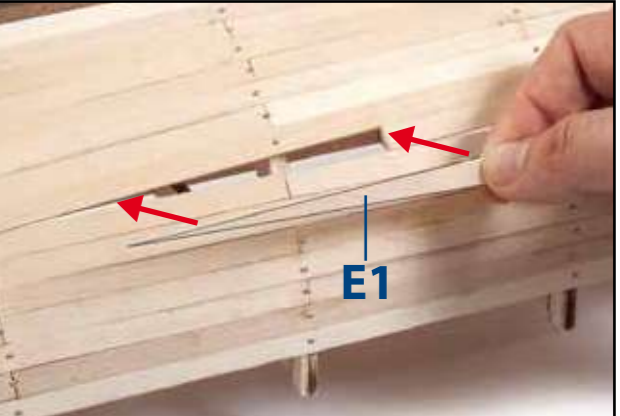
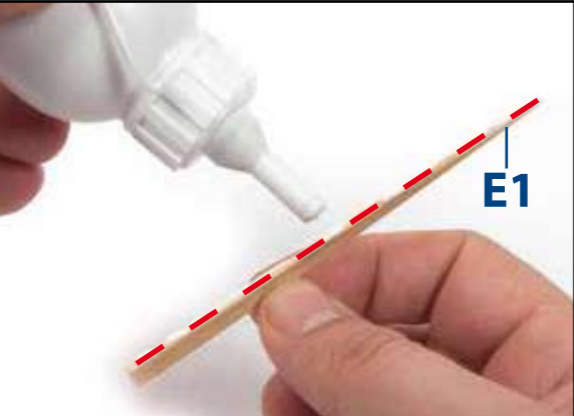
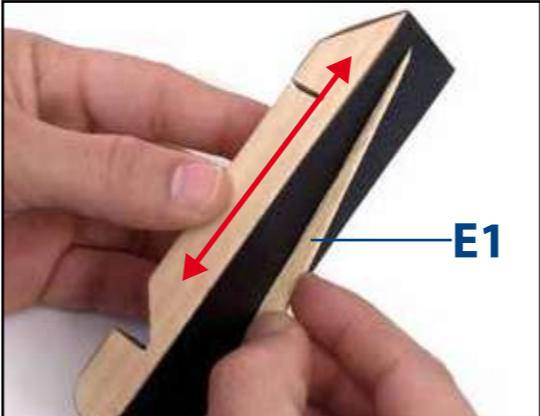
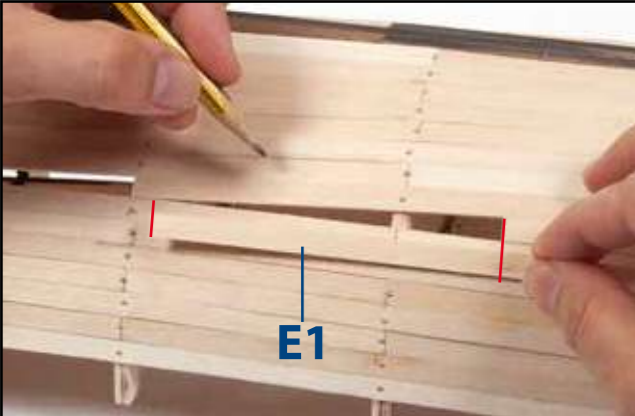
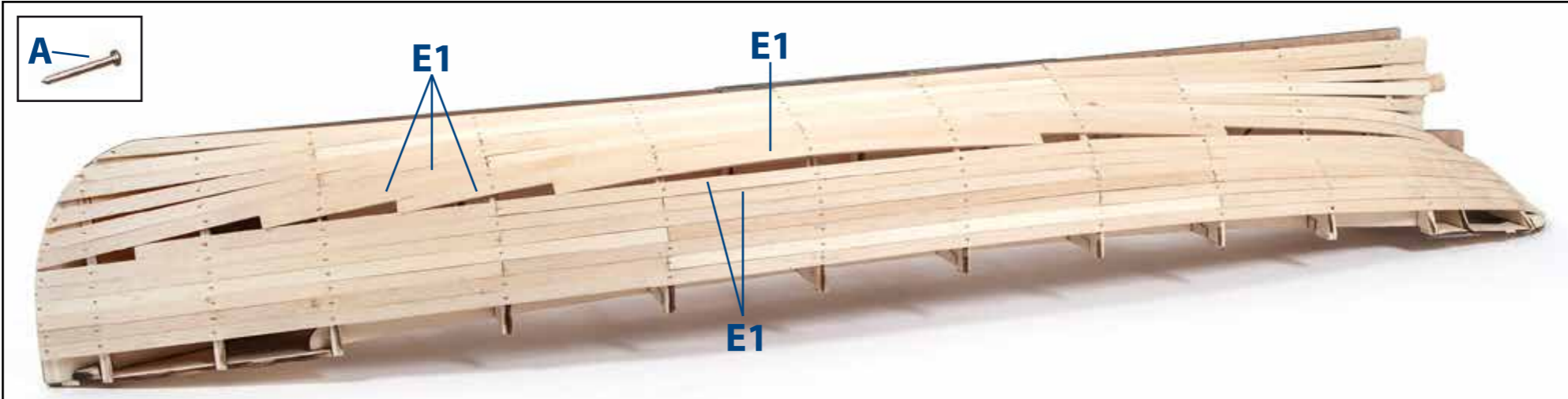
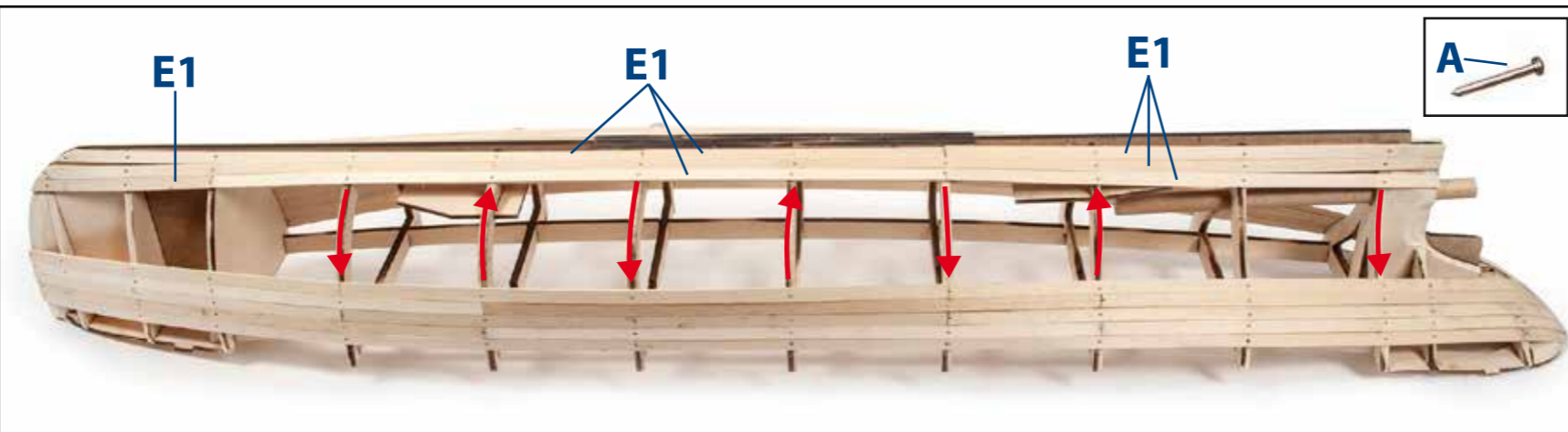
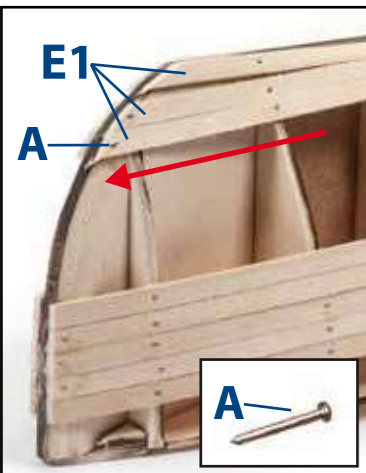

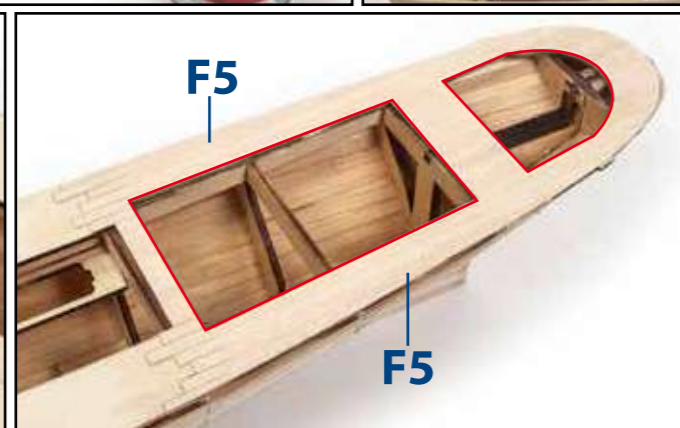
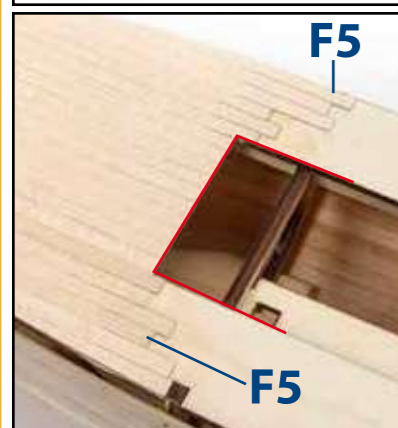
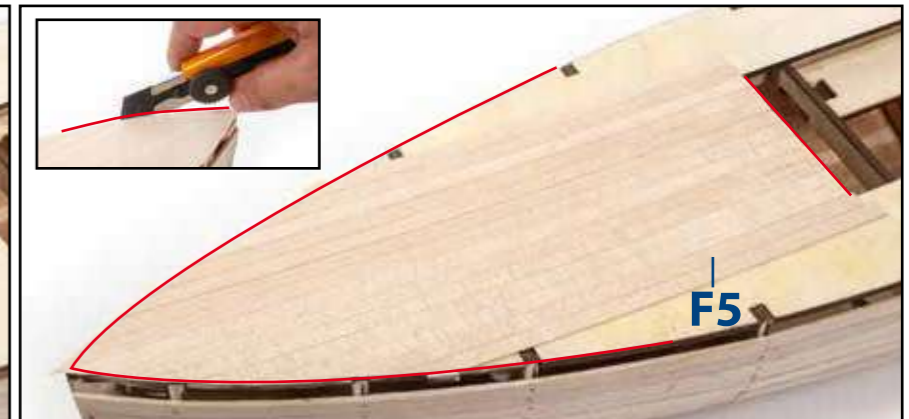
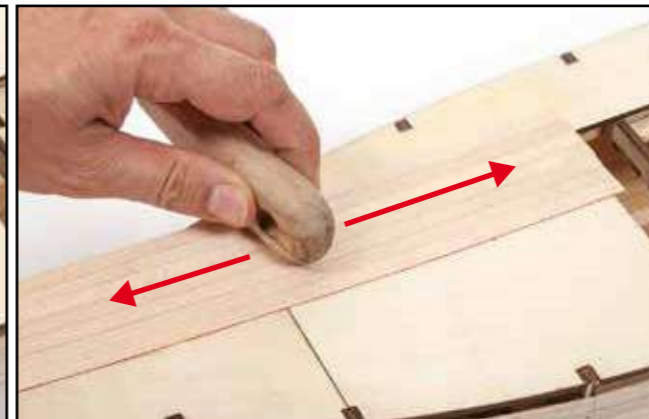
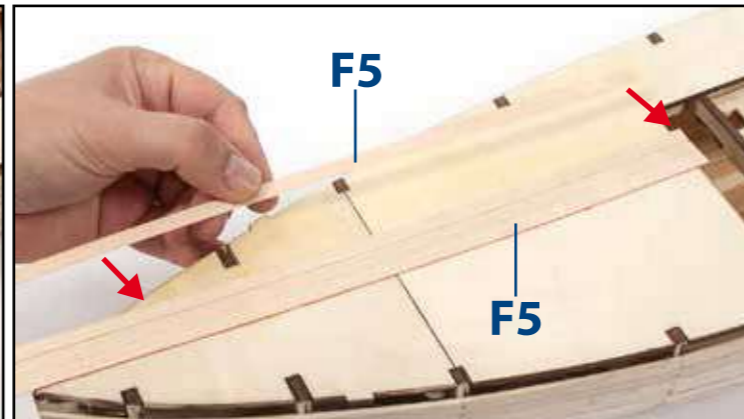
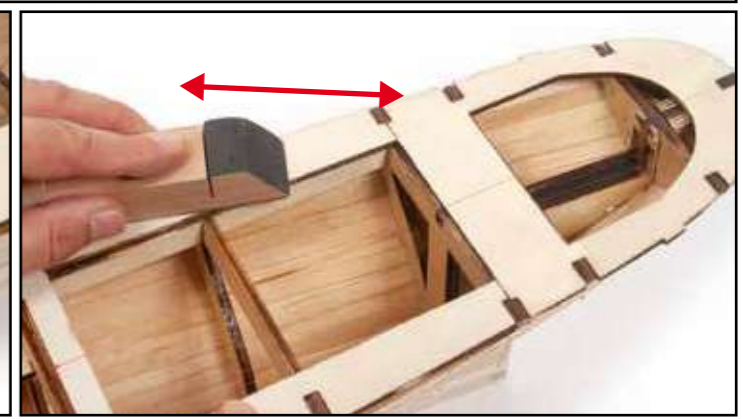
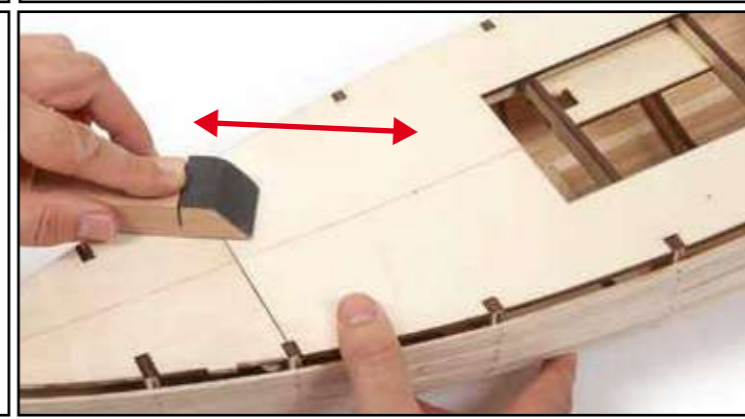
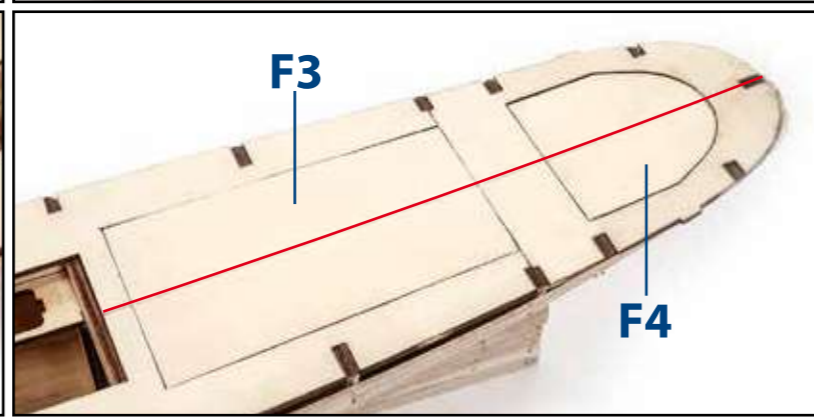
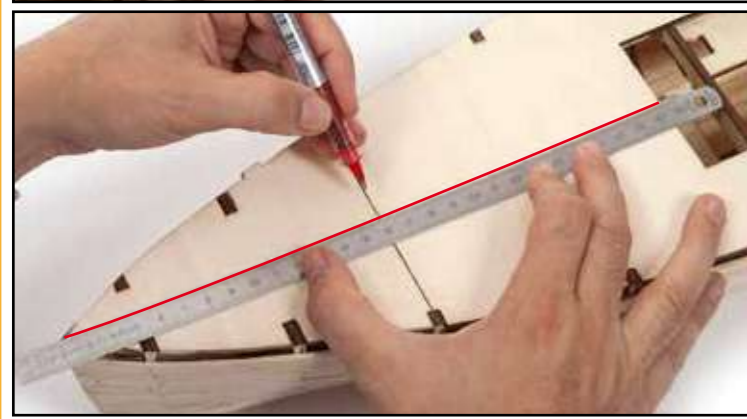
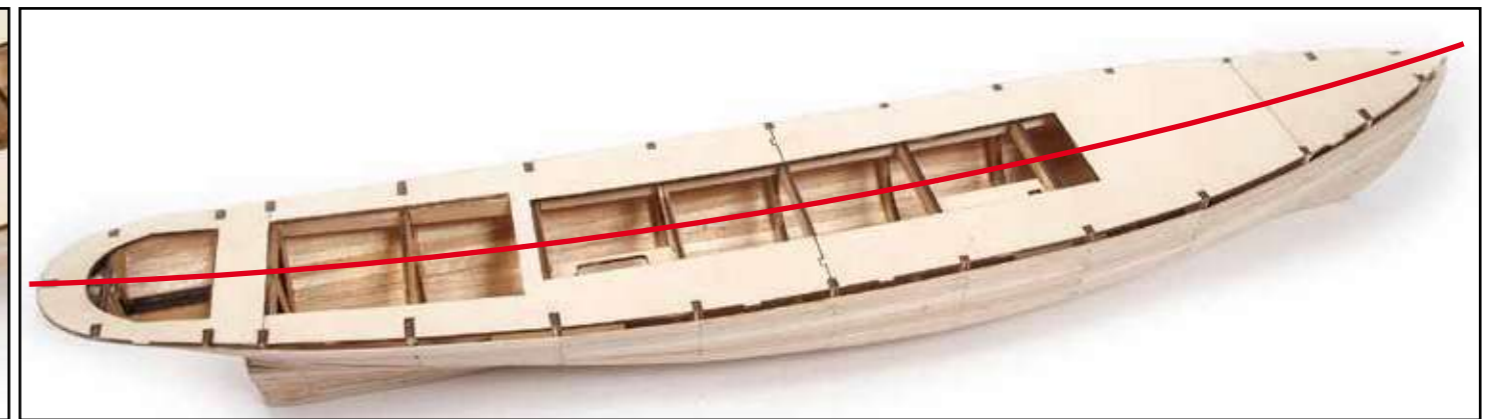
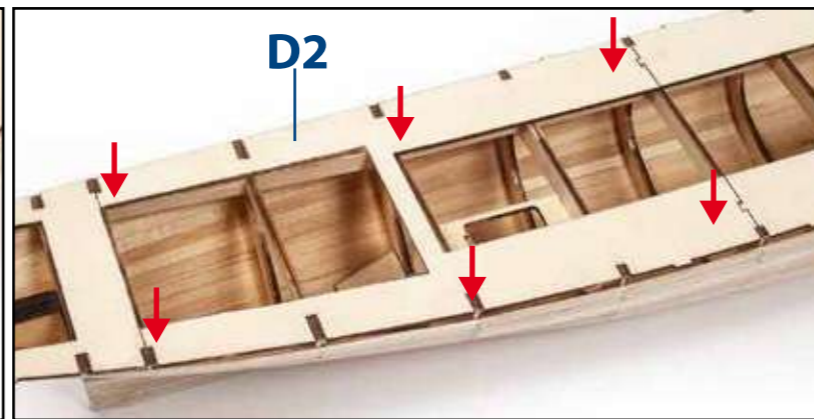
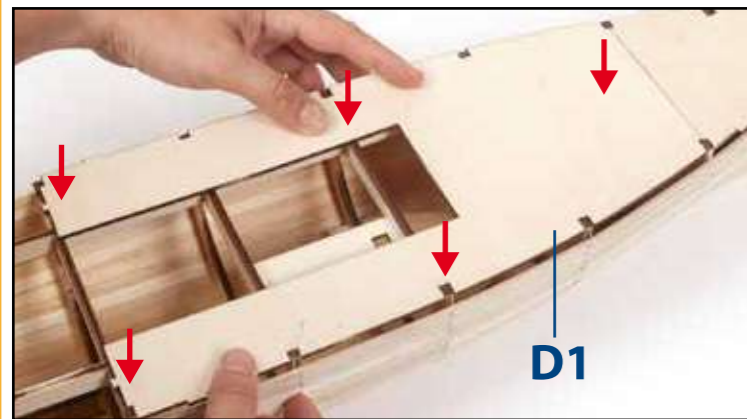
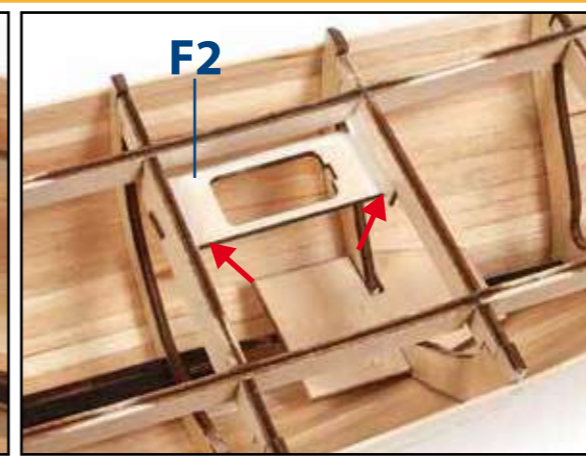
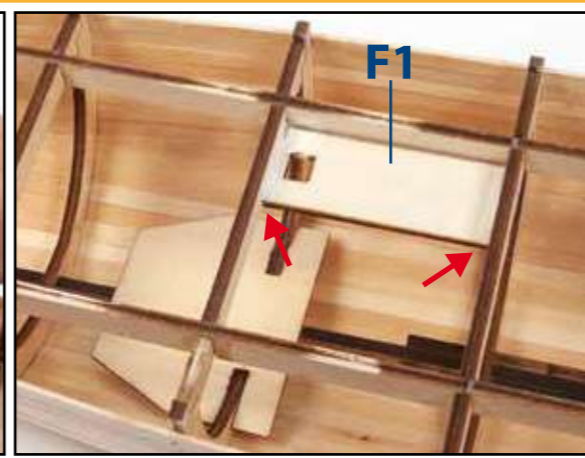
F

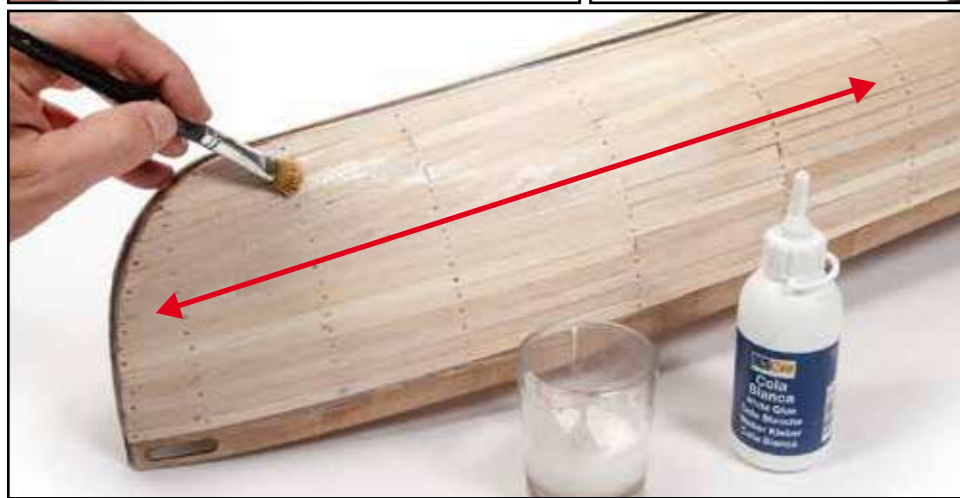
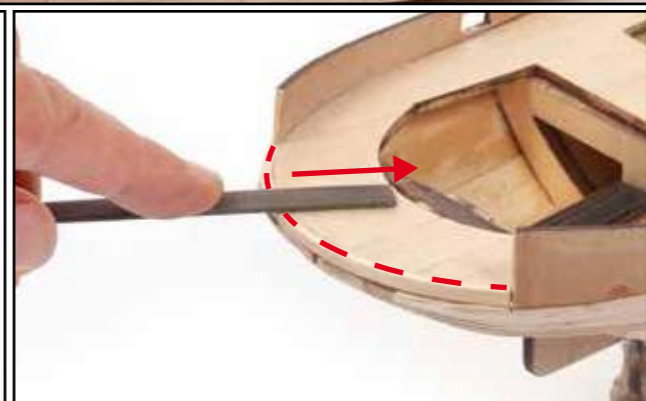
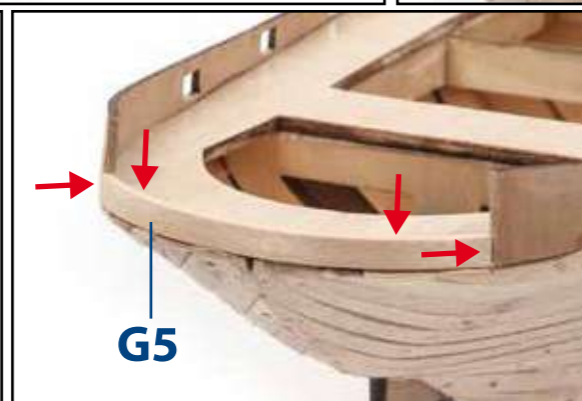
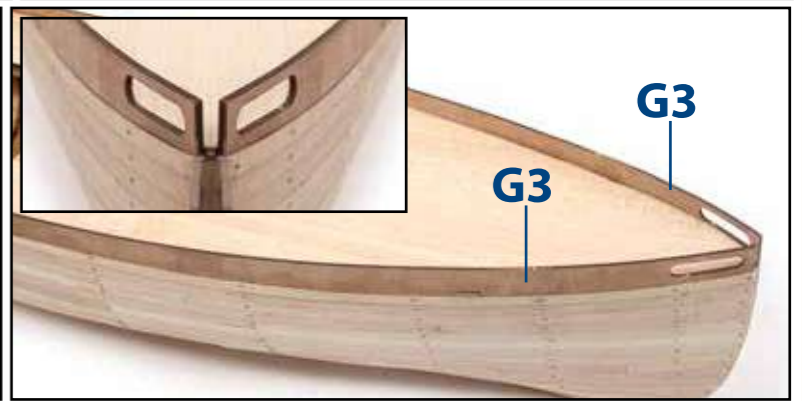
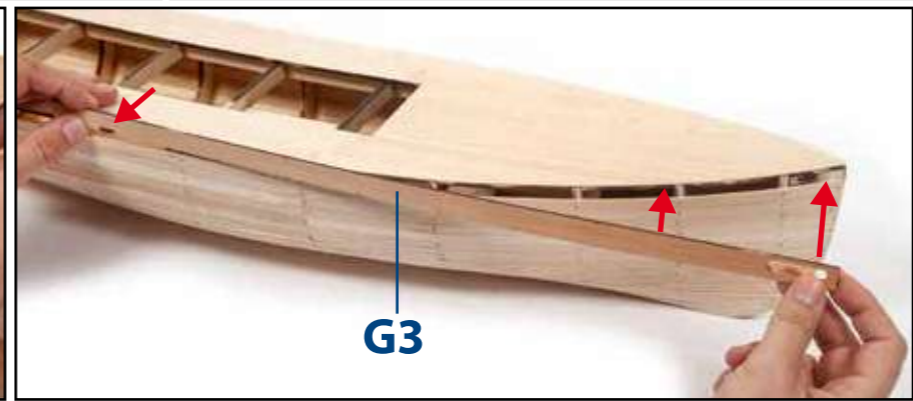
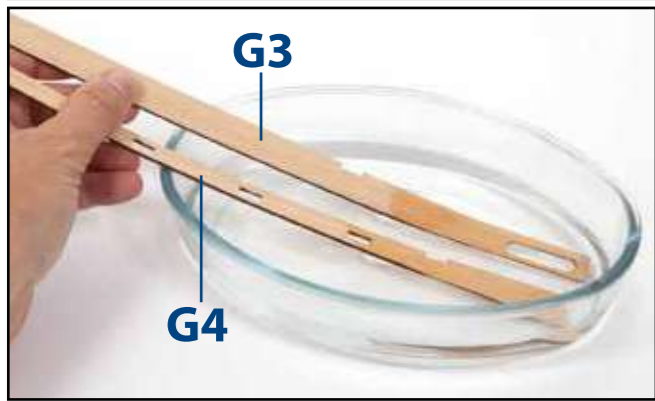
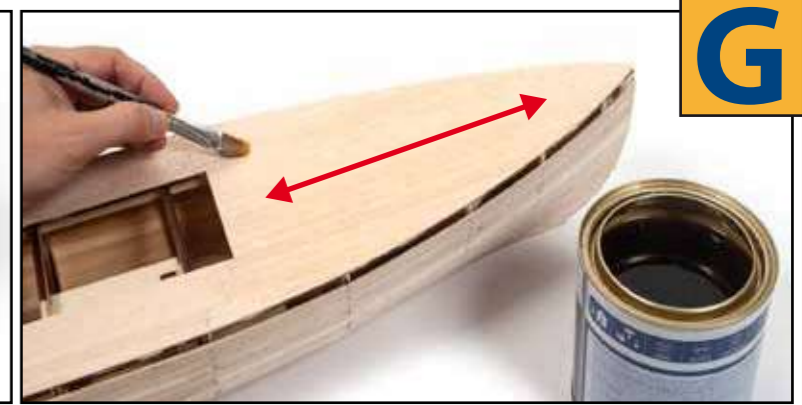
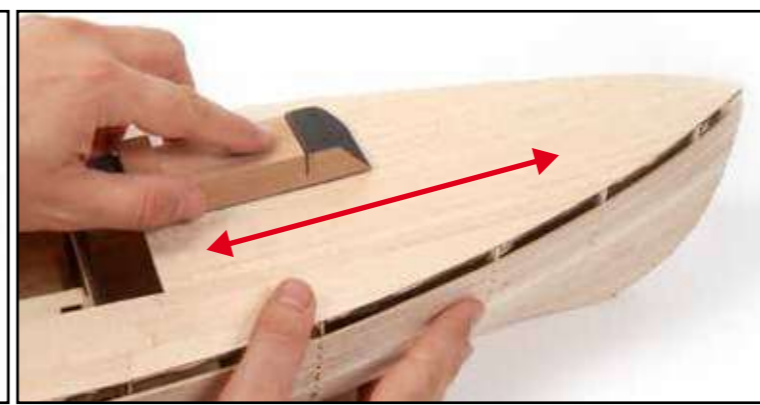
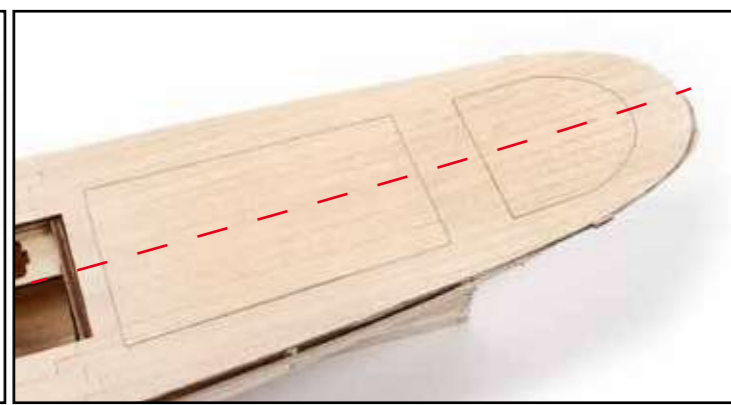
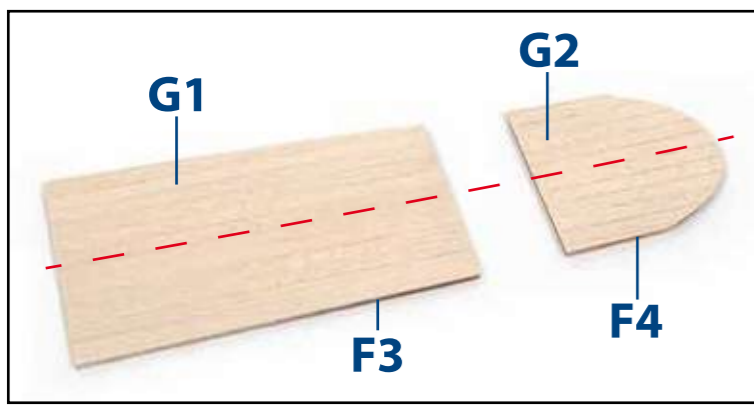

H

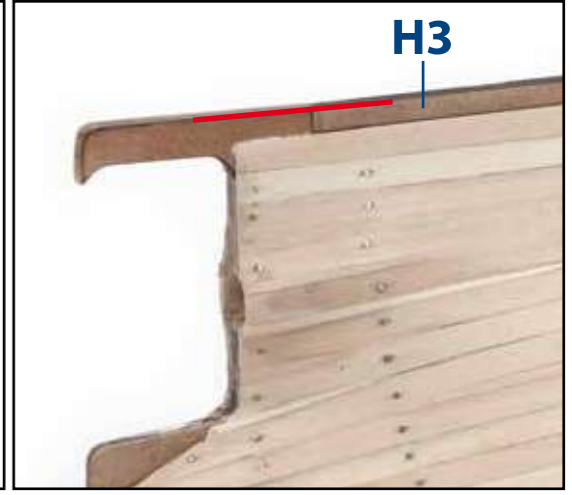
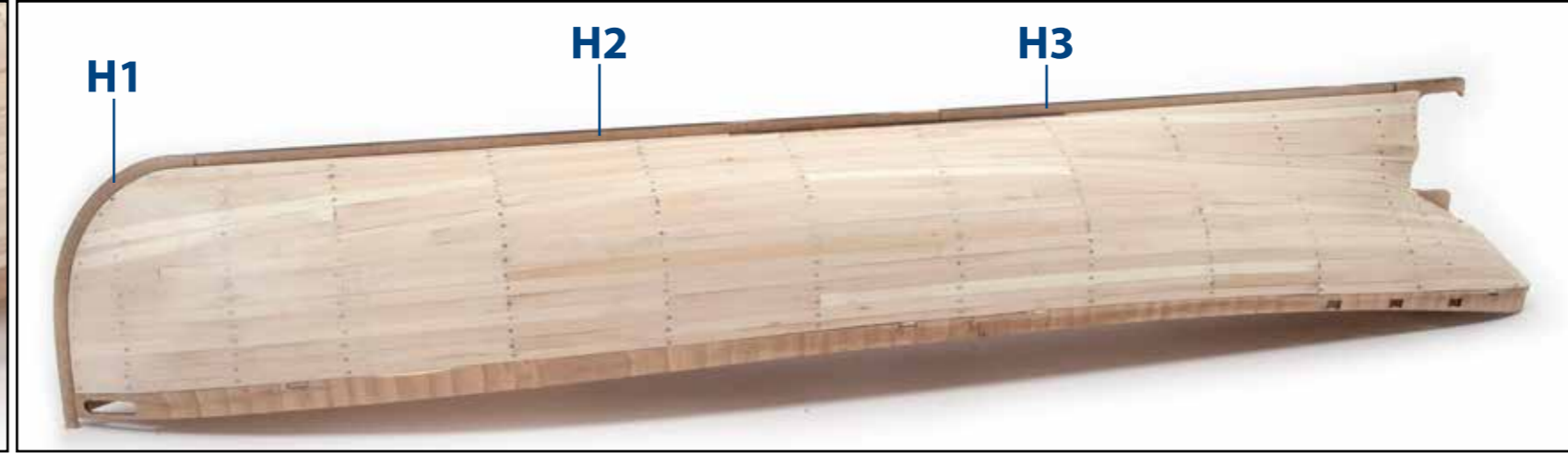
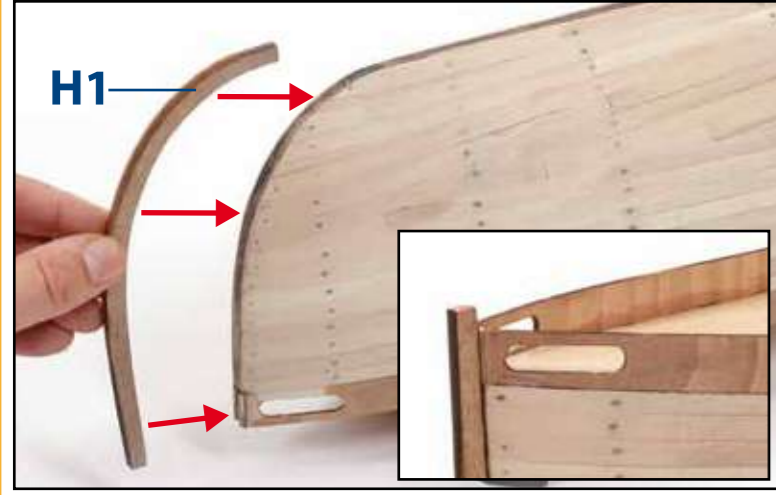
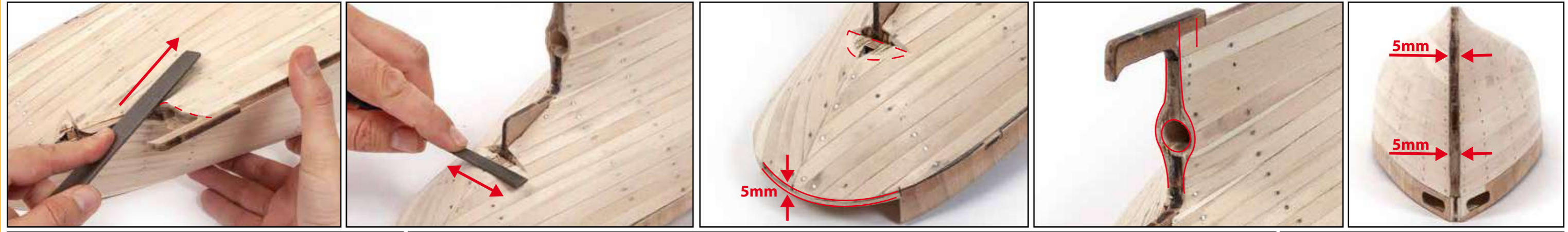

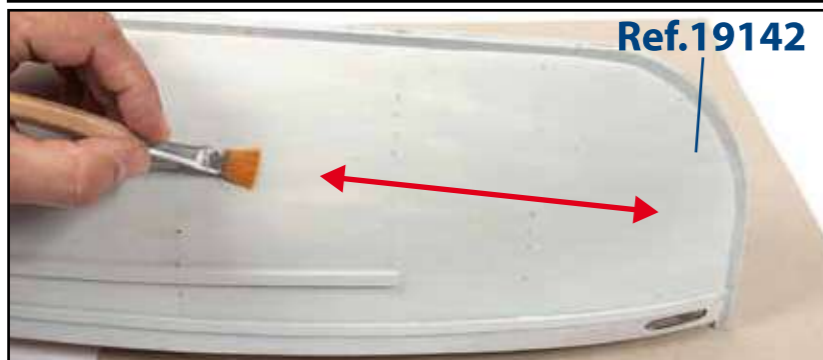
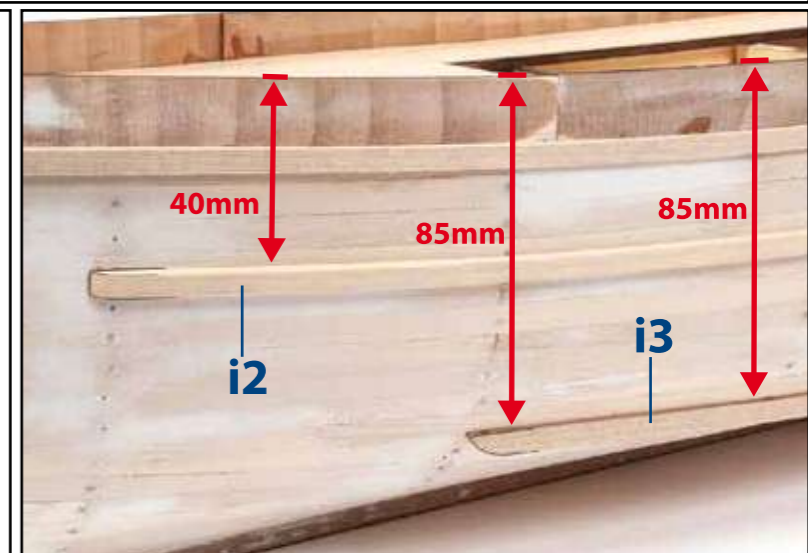
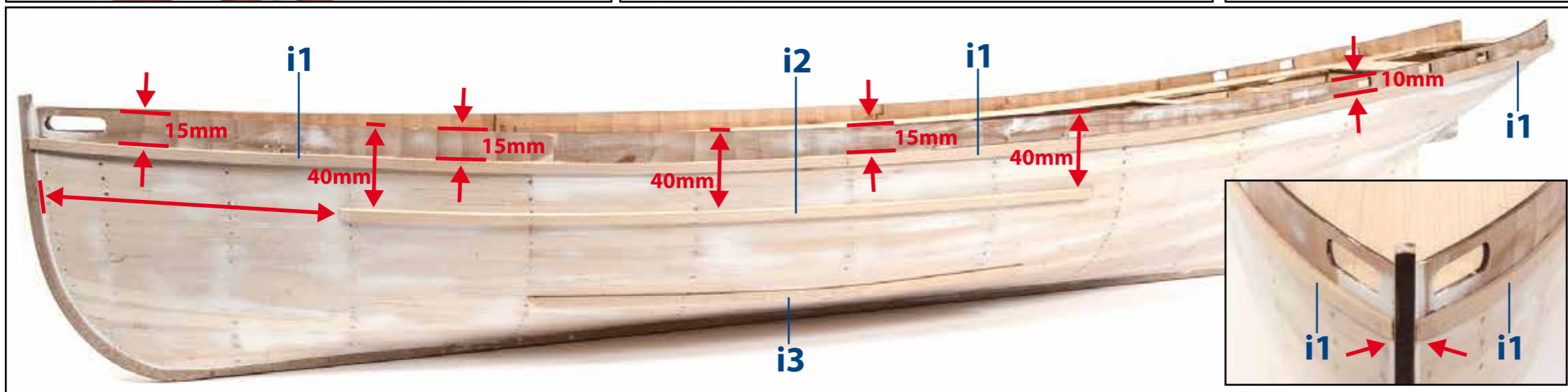
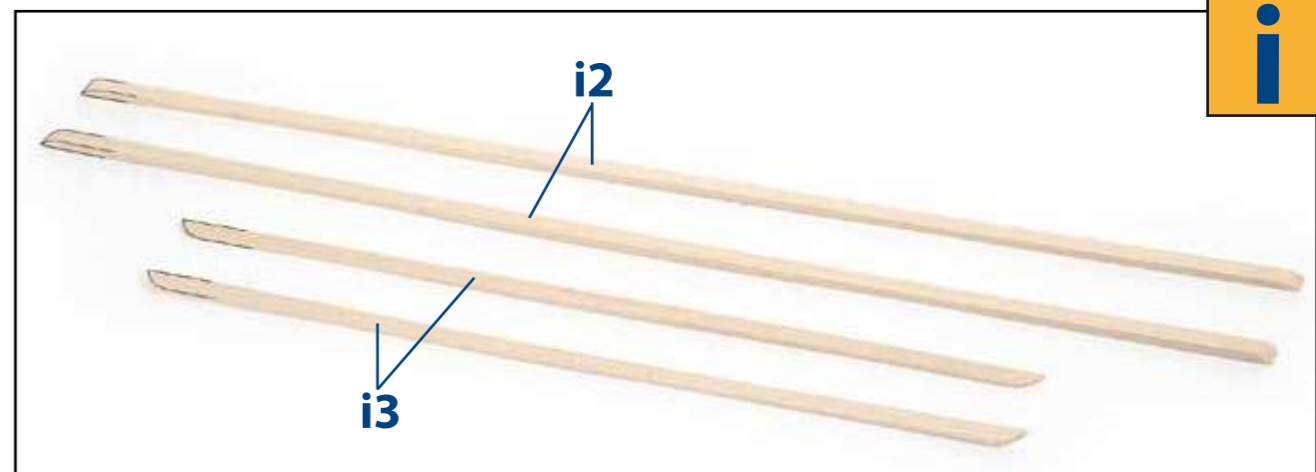
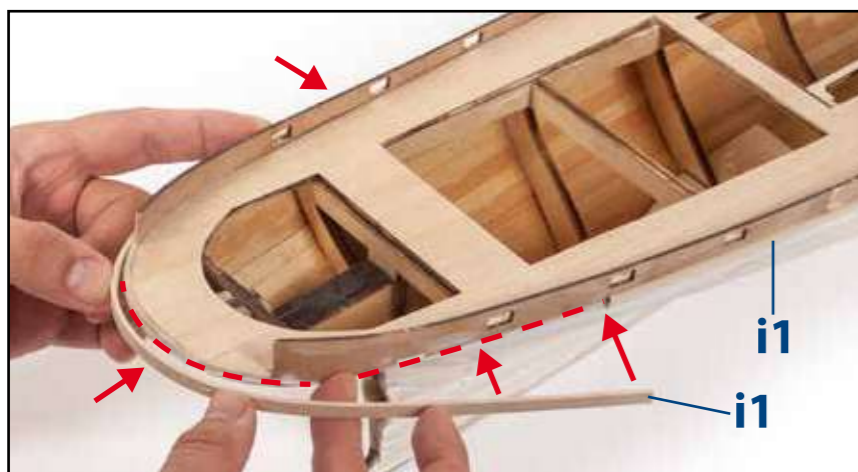

J

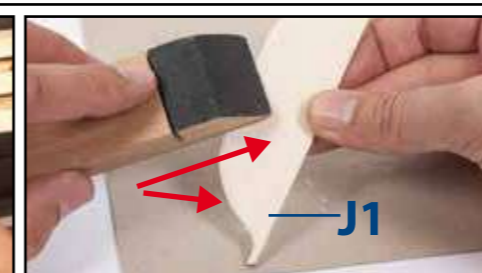
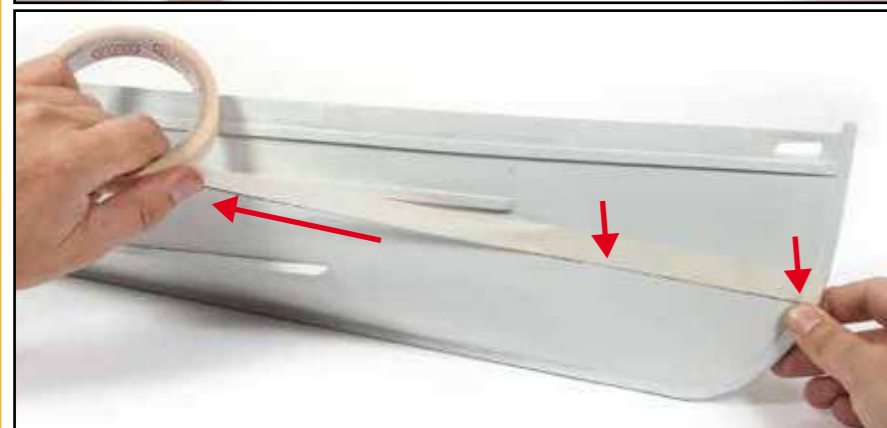
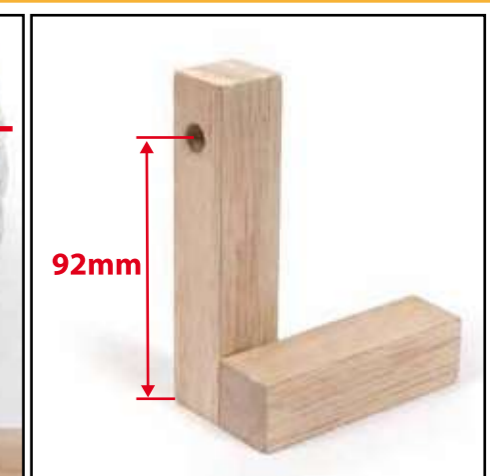
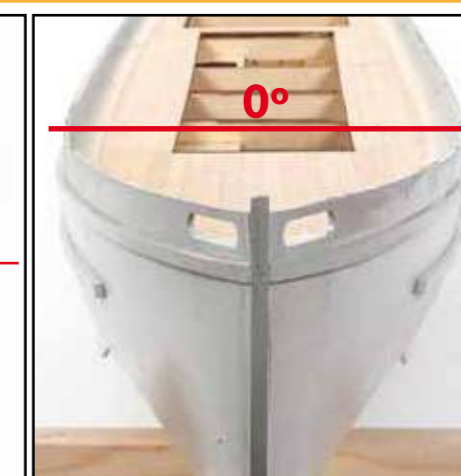

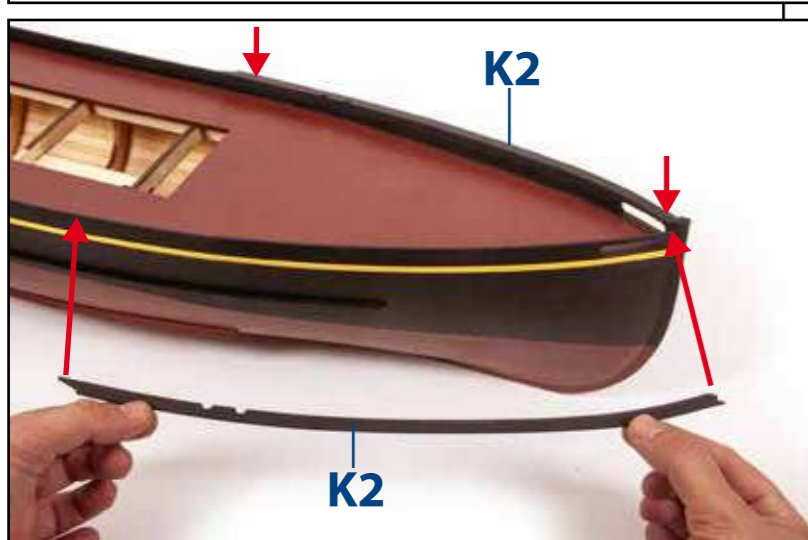
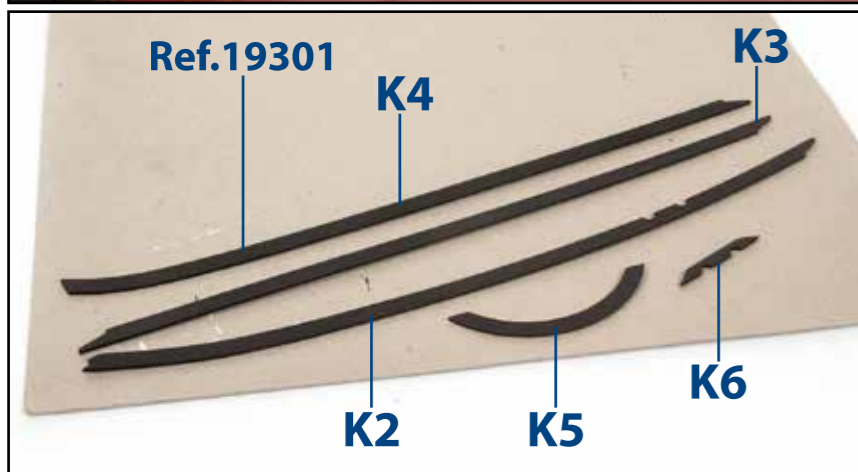
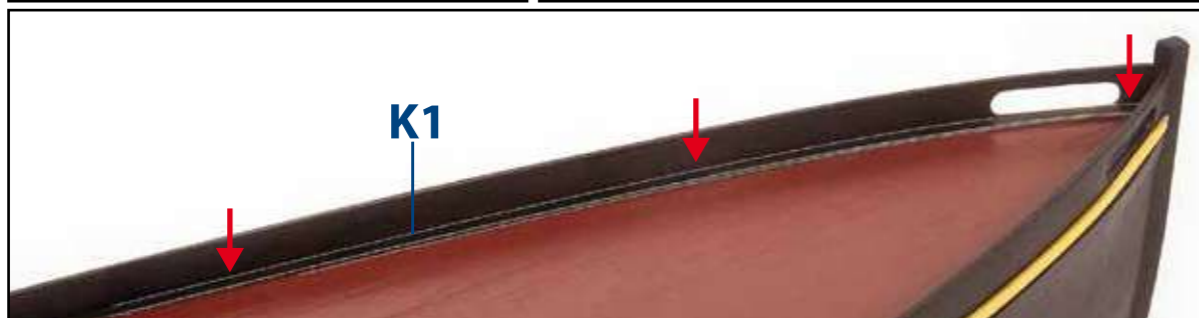
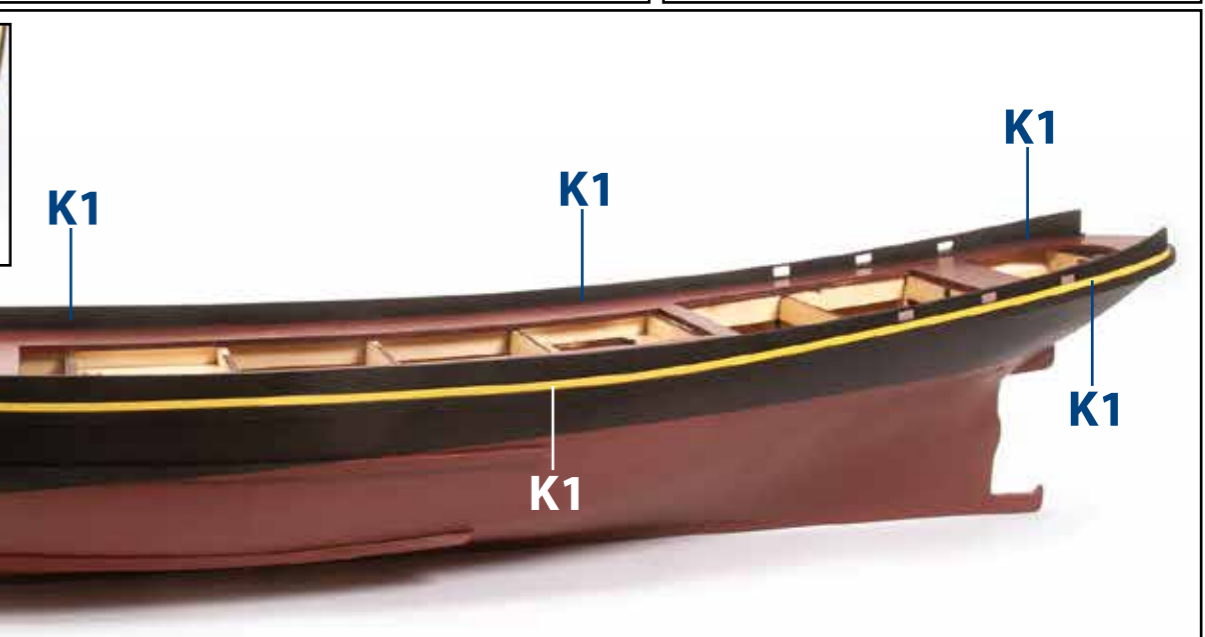
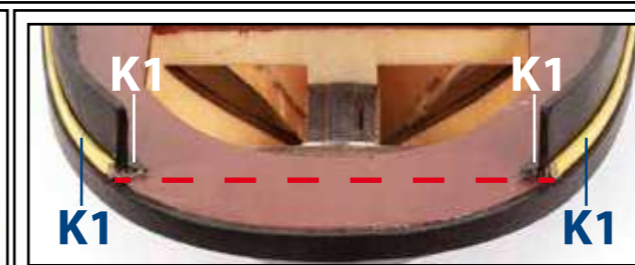
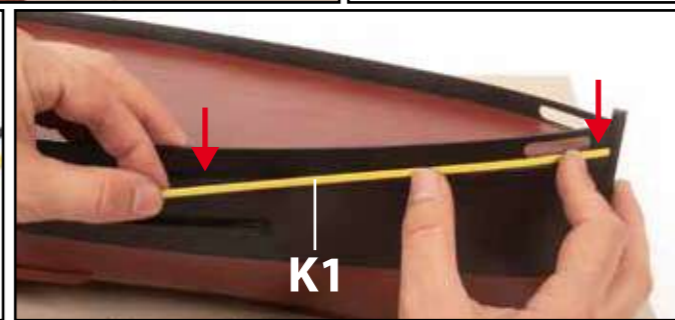
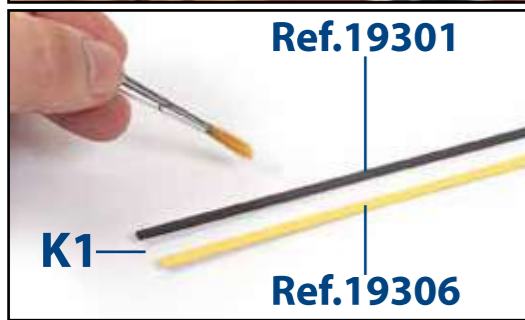
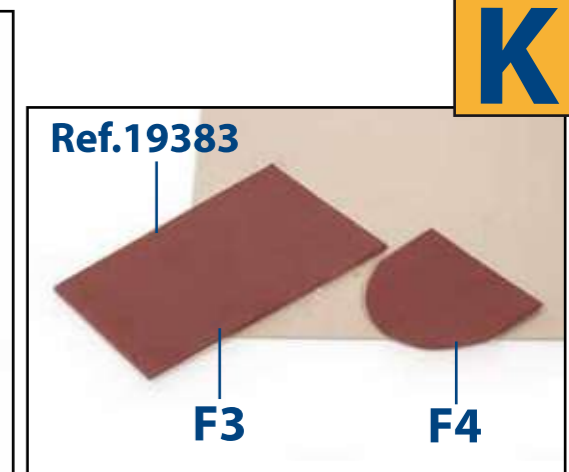

L

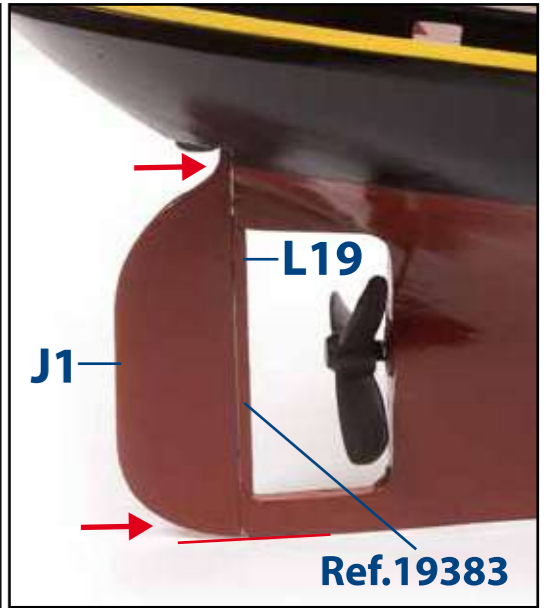
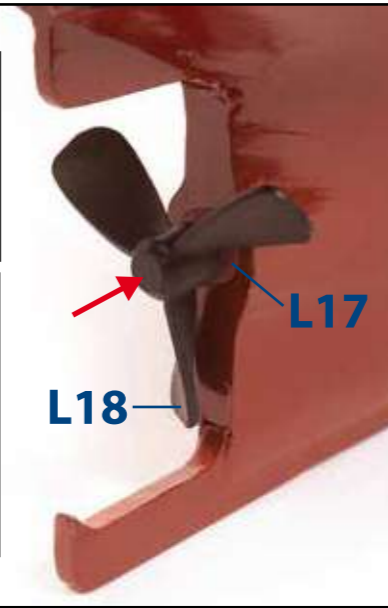
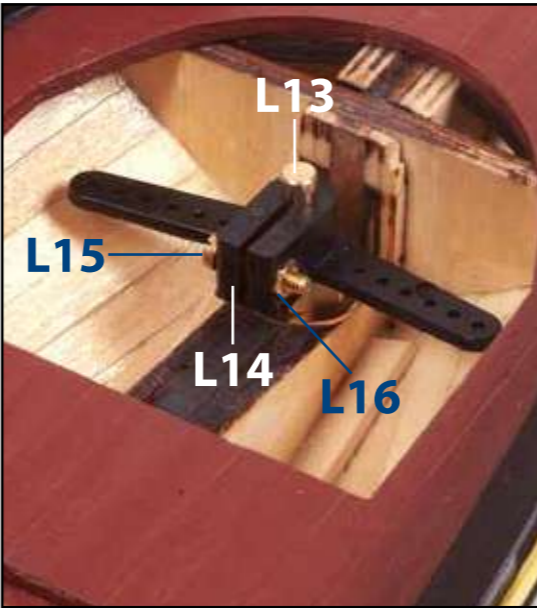
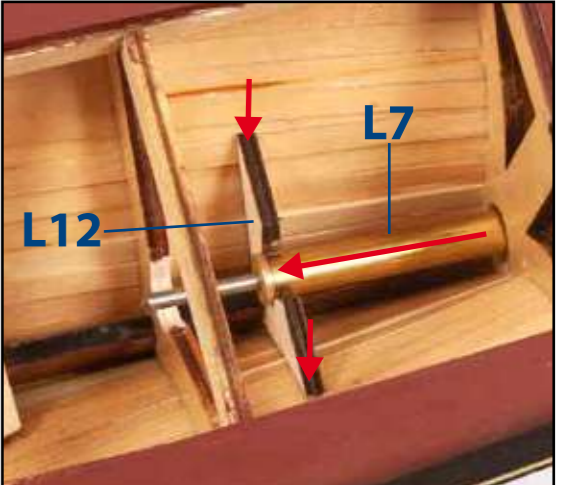
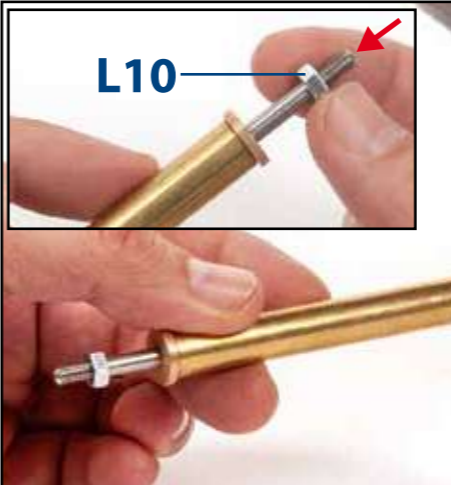
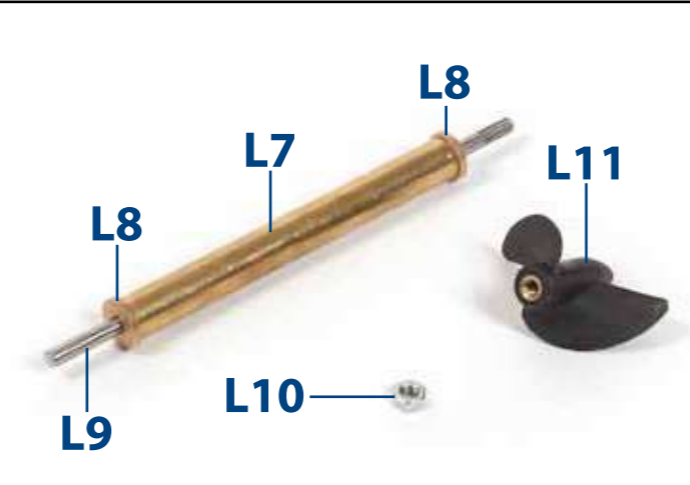
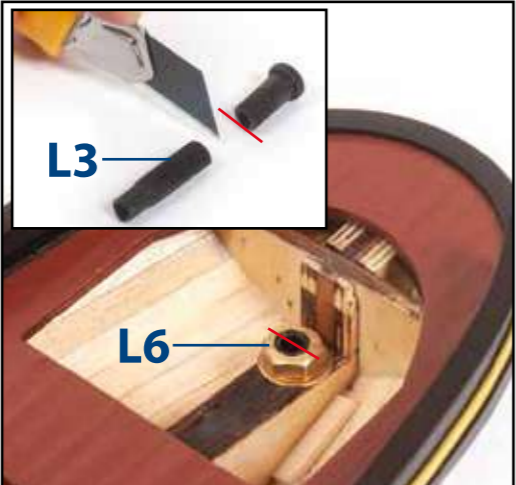
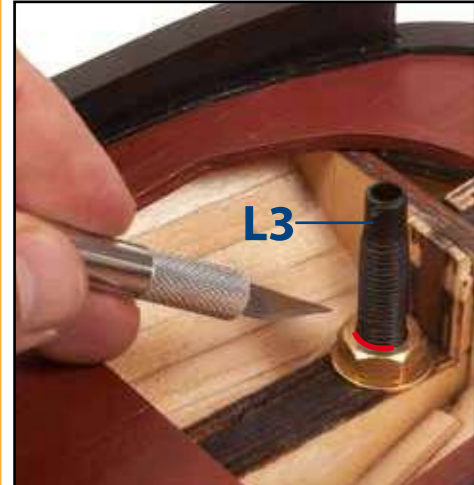
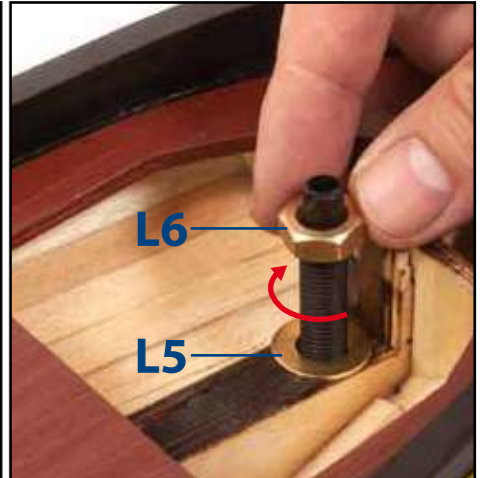
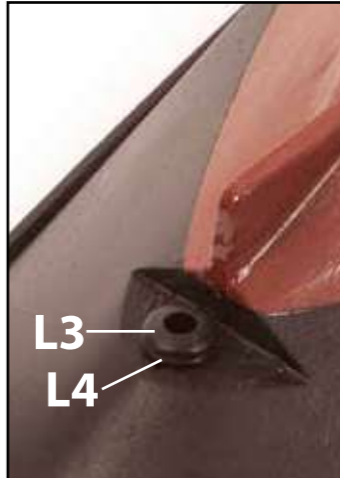
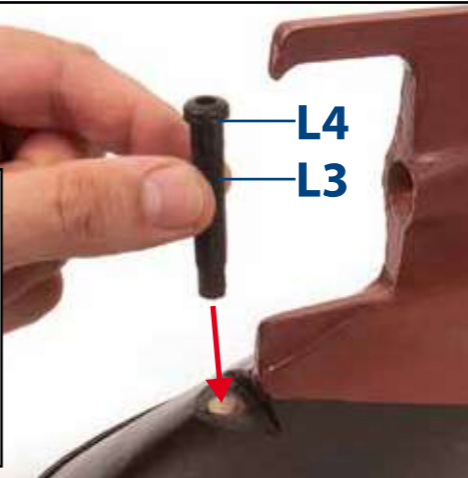
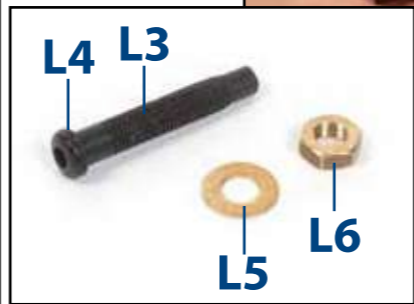
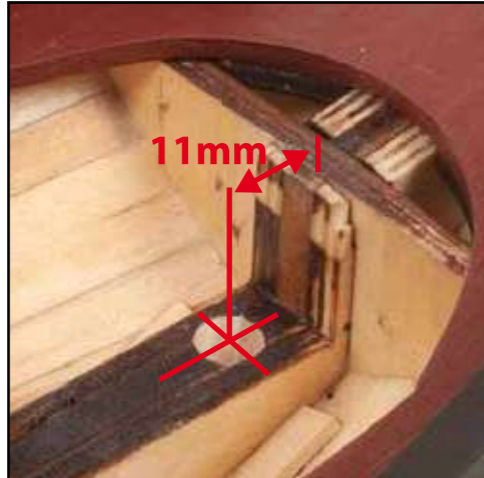
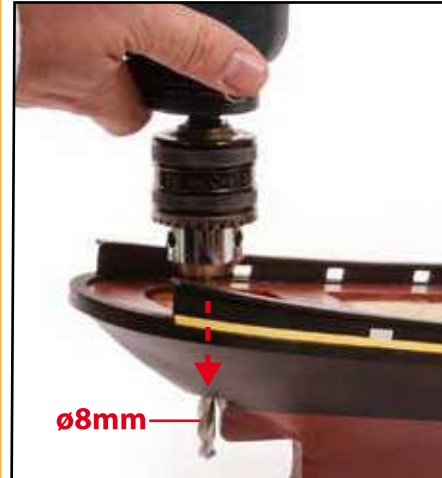
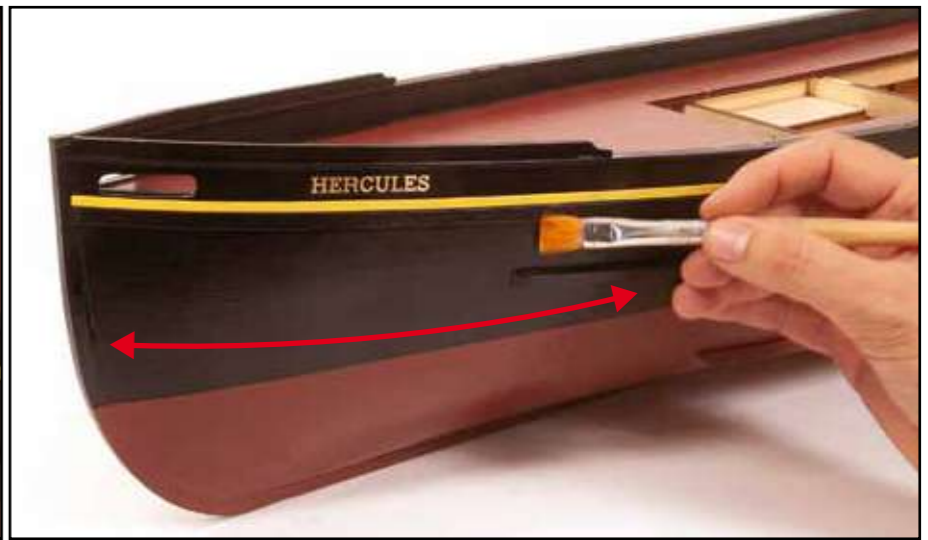
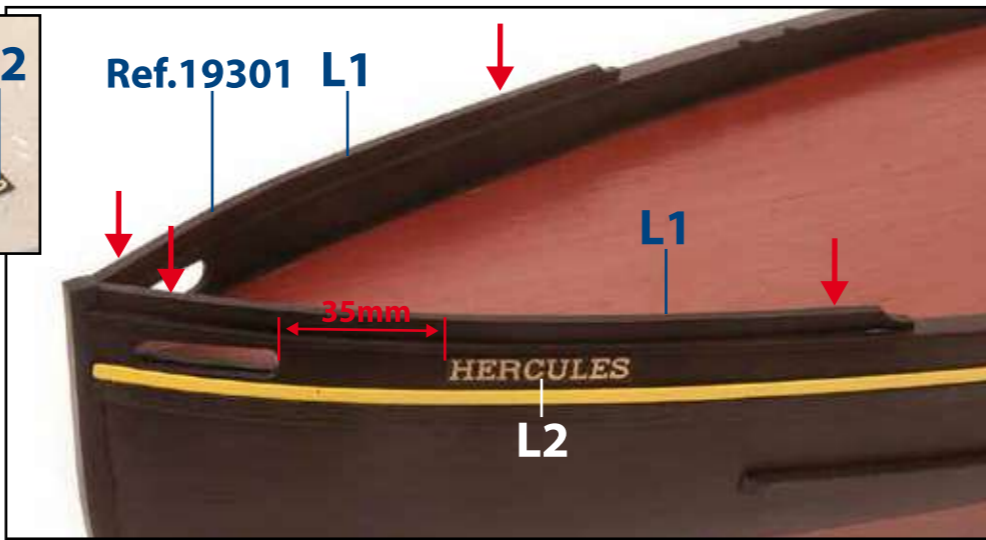
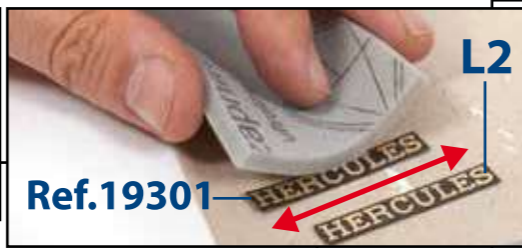

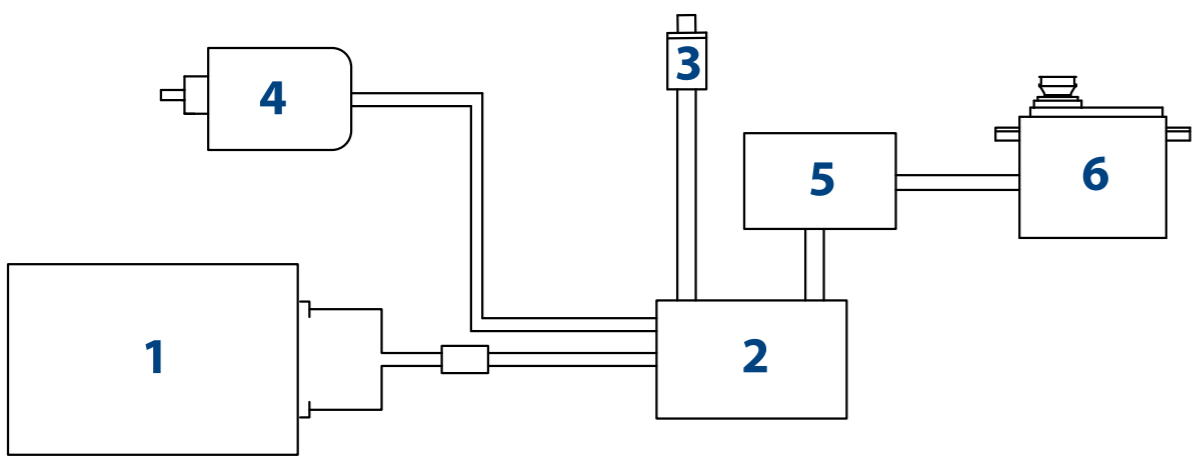
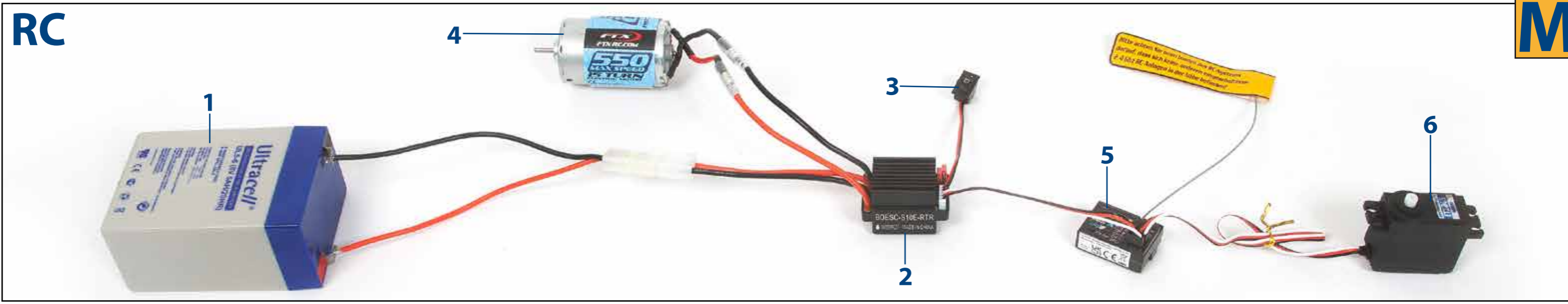

ESQUEMA ELÉCTRICO

1- Batería. 2- Variador electrónico. 3-Interruptor. 4-Motor. 5-Receptor. 6-Servo.

CIRCUIT DIAGRAM

1-Battery. 2-Phase shifter. 3-Switch. 4-Motor. 5-Receiver. 6-Servo.

SCHÉMA ÉLECTRIQUE

1-Batterie. 2-Variateur électronique. 3-Interrupteur. 4-Moteur. 5-Récepteur. 6-Servo.

SCHEMA ELETTRICO

1-Batteria. 2-Variatore elettrico. 3-Interruttore. 4-Motore. 5-Ricevente. 6-Servo.

ELEKTRODIAGRAMM

1-Akku. 2-Regler. 3-Schalter. 4-Motor. 5-Empfänger. 6-Servo.

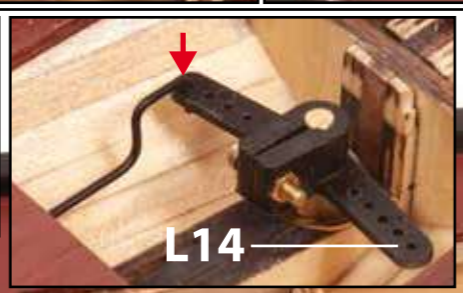
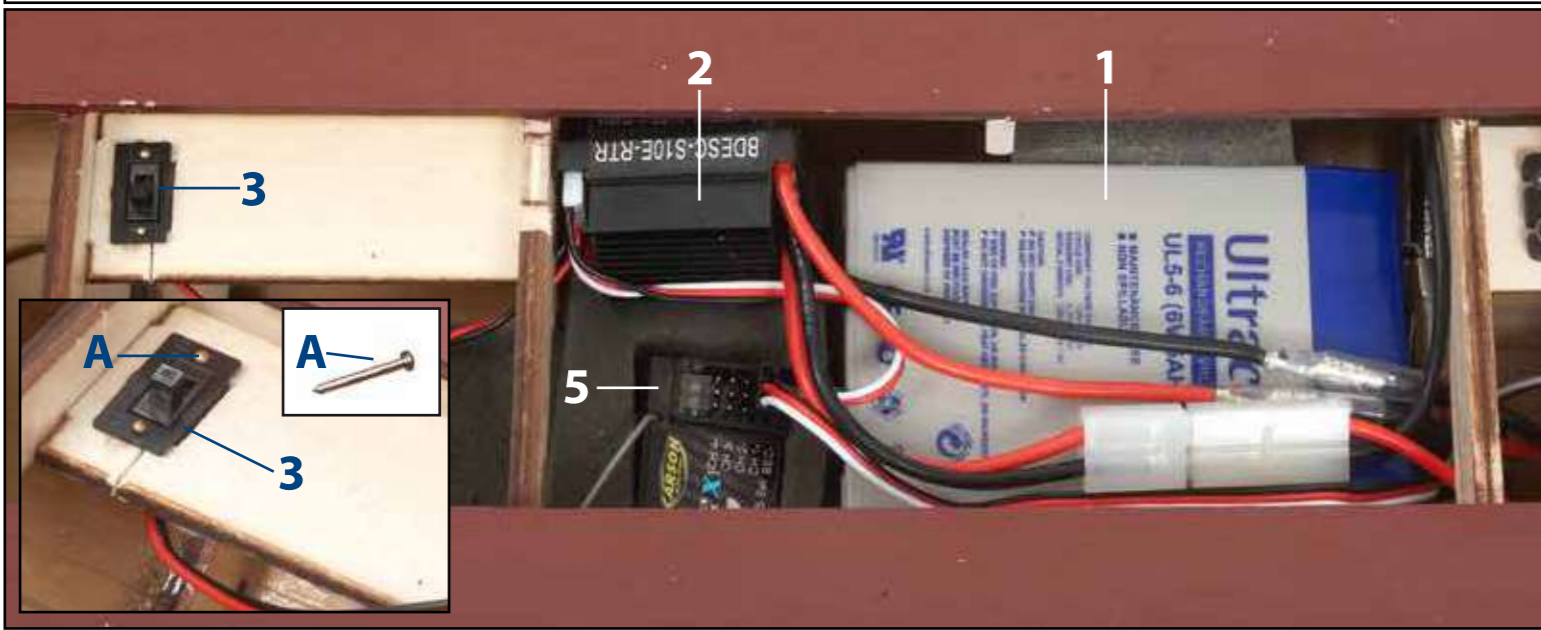
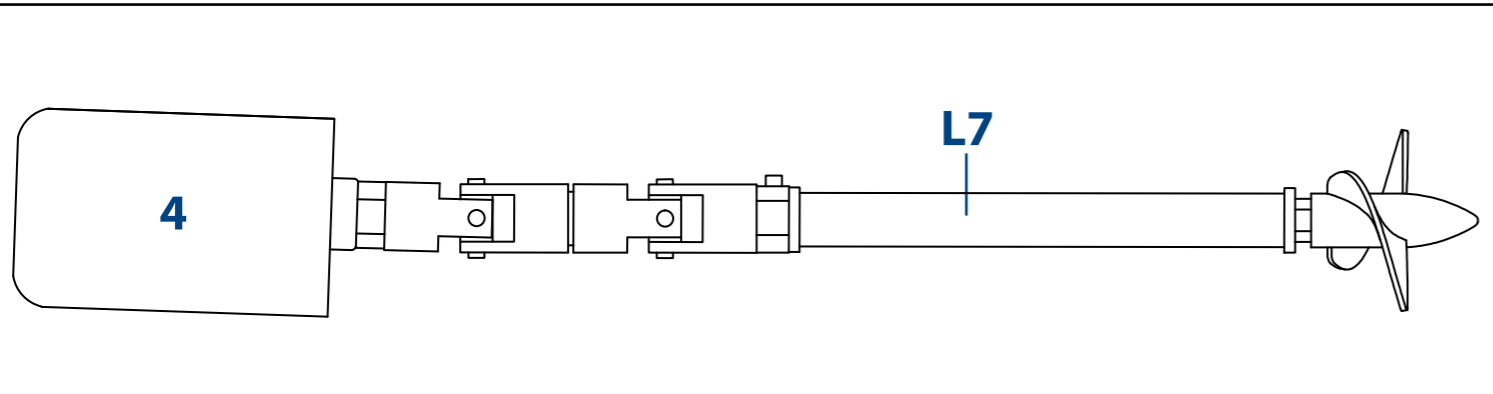

N

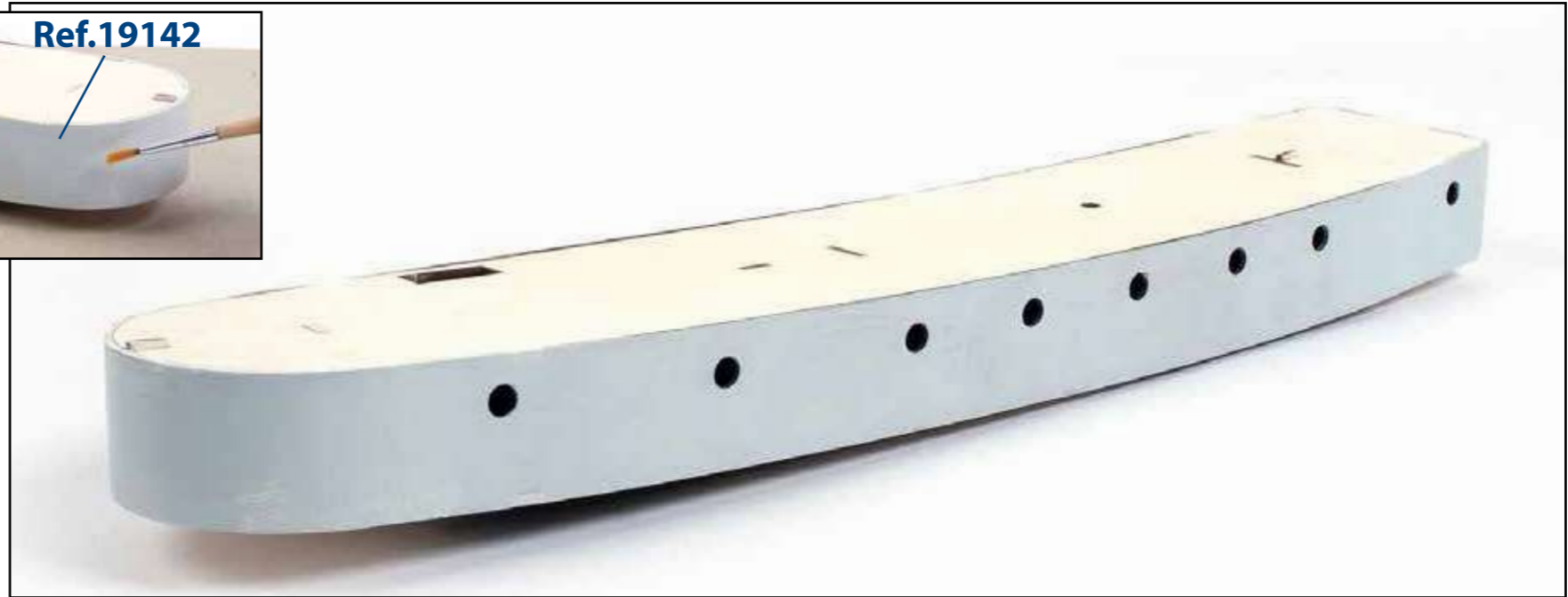
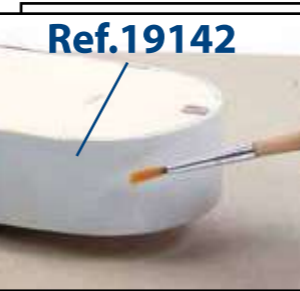
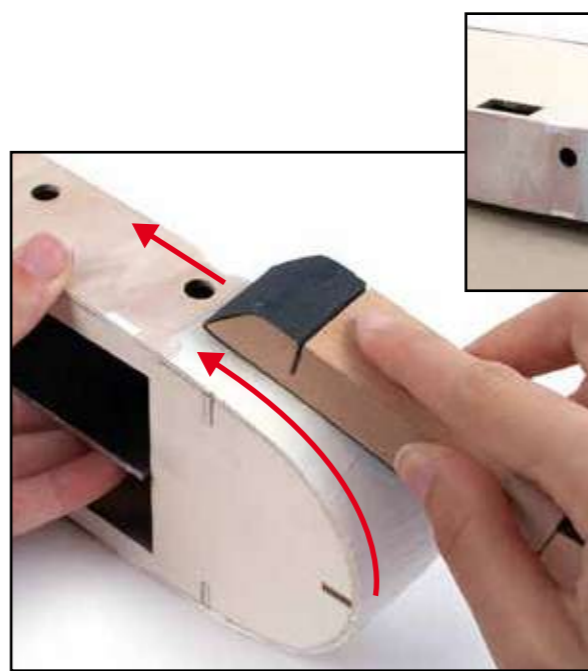
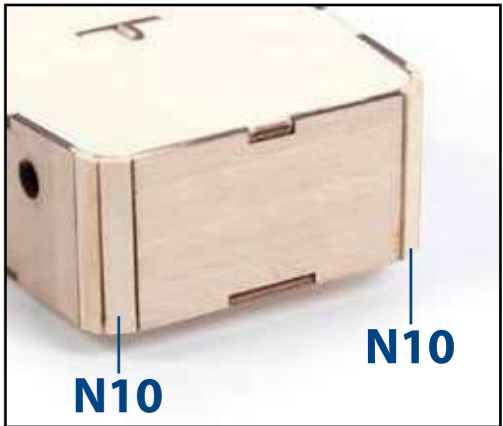
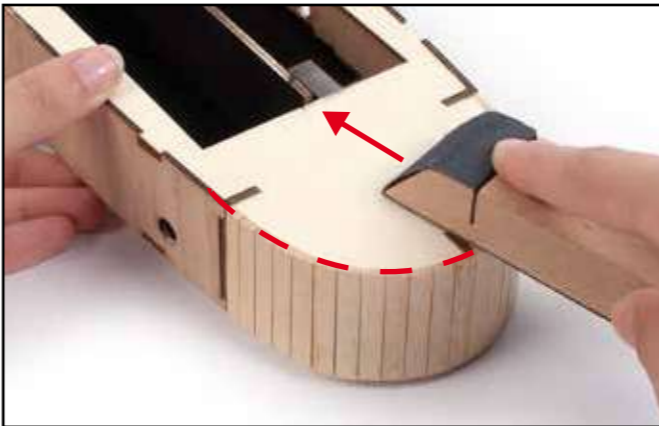
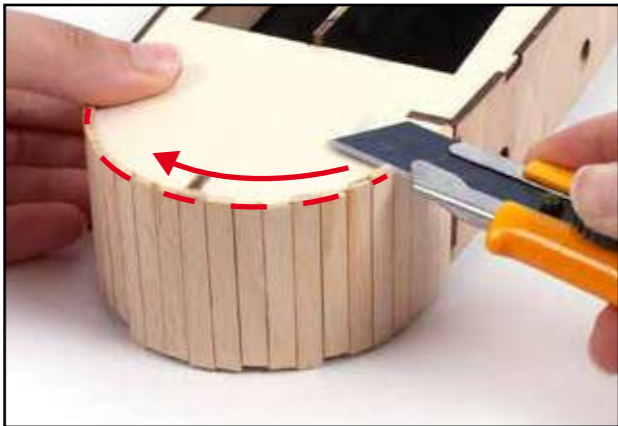
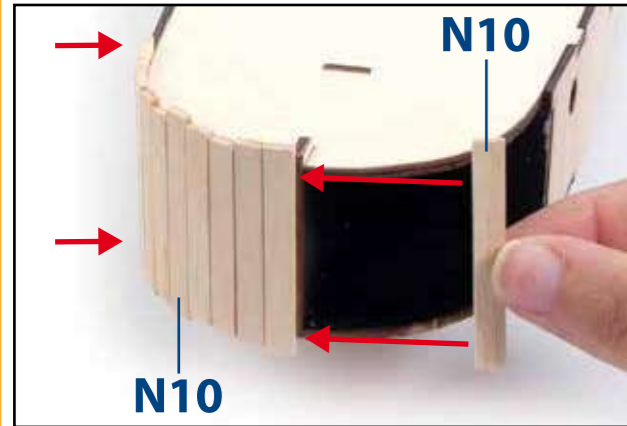
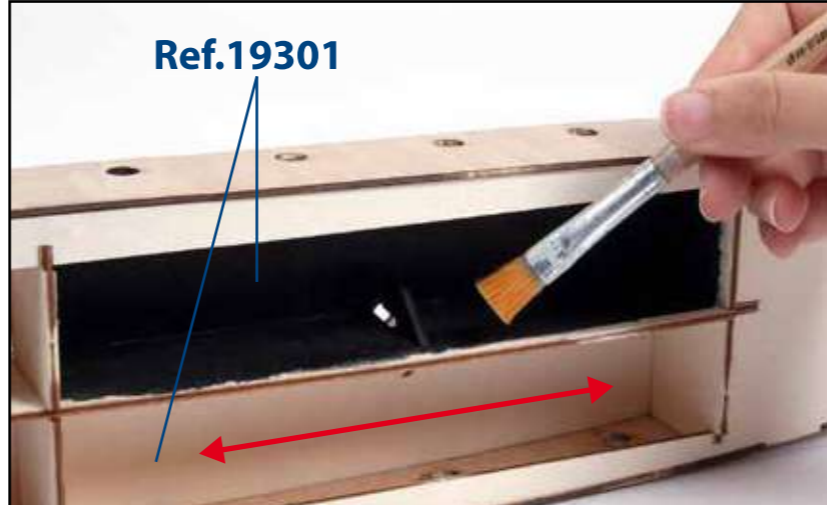
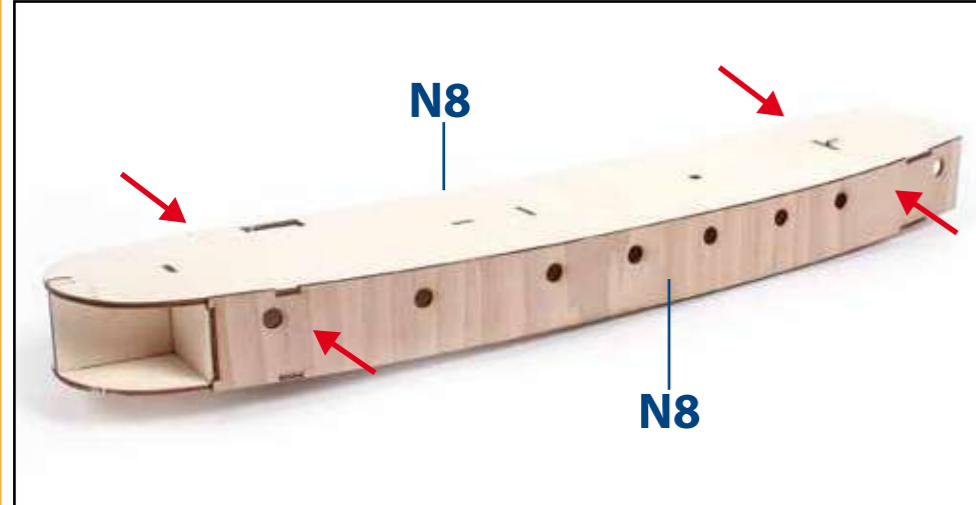
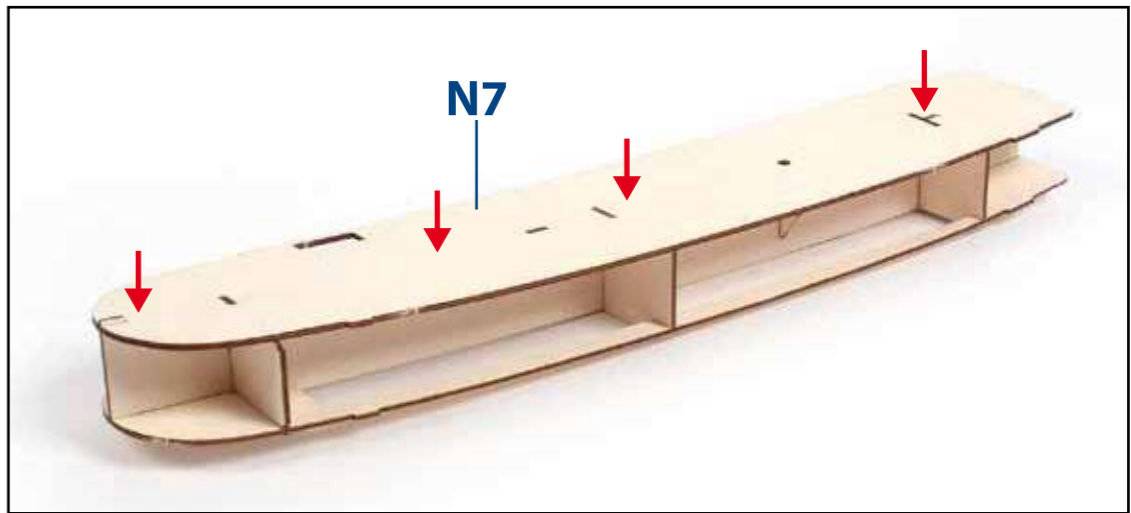
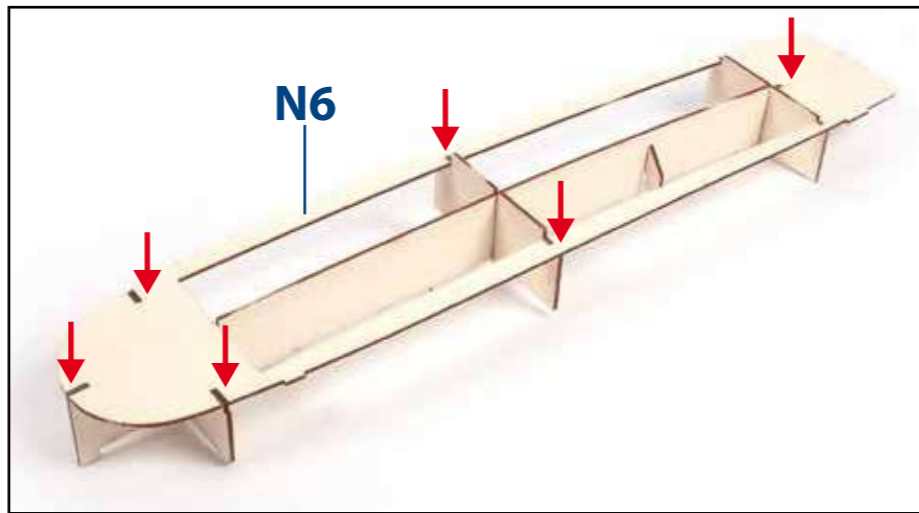
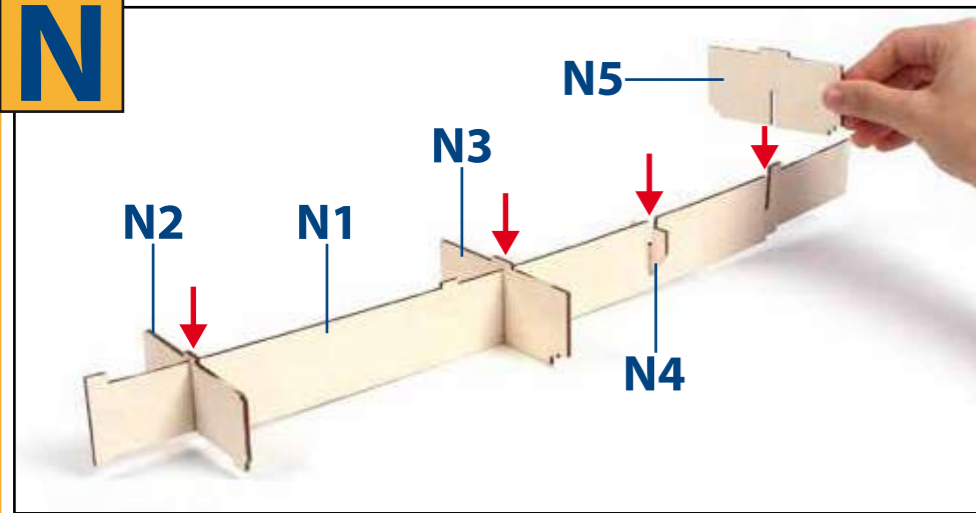

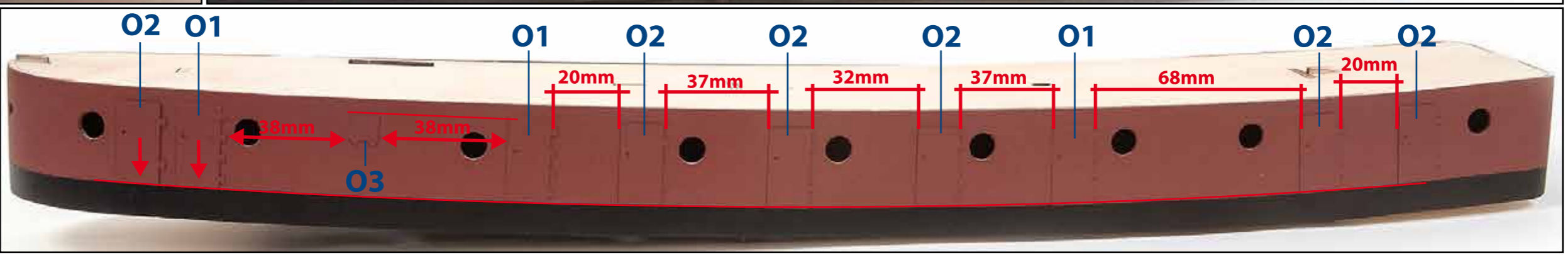
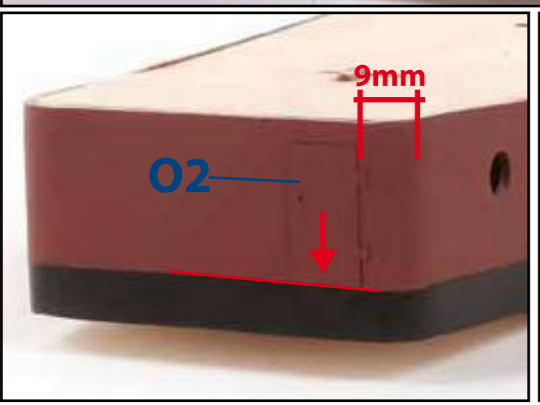
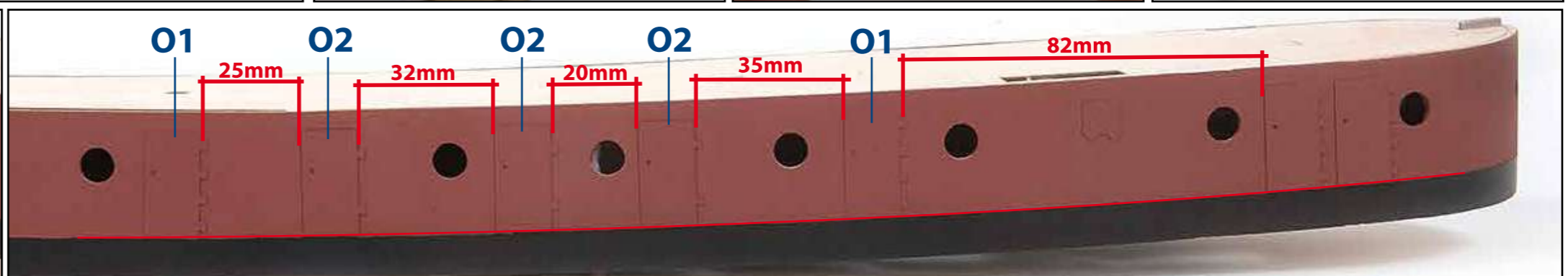
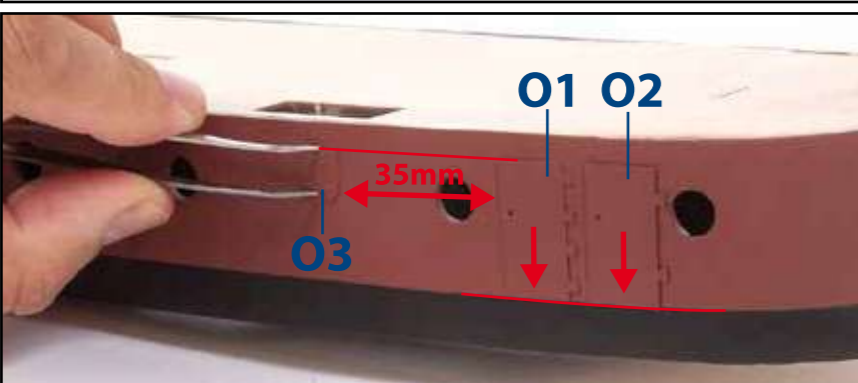
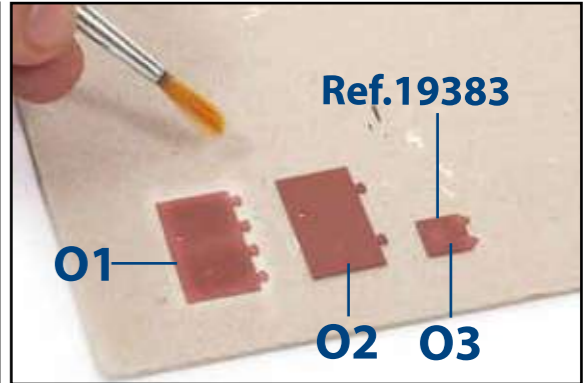
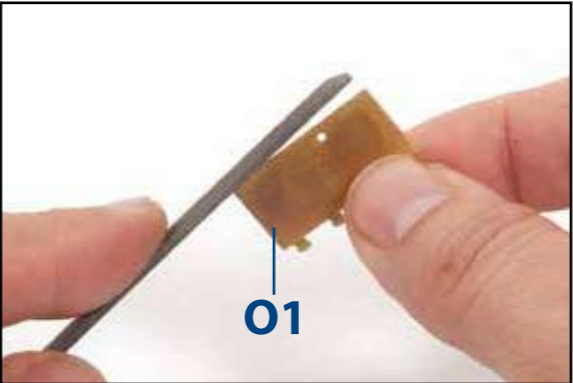
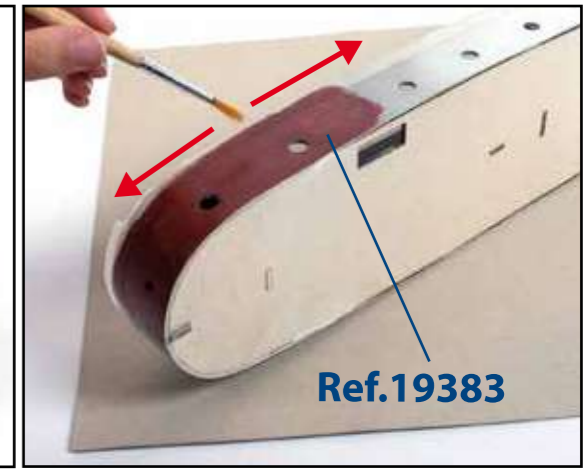
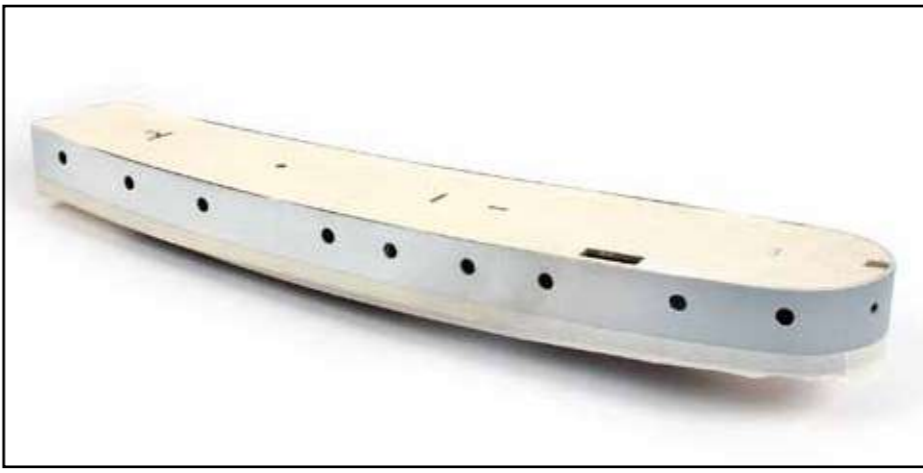
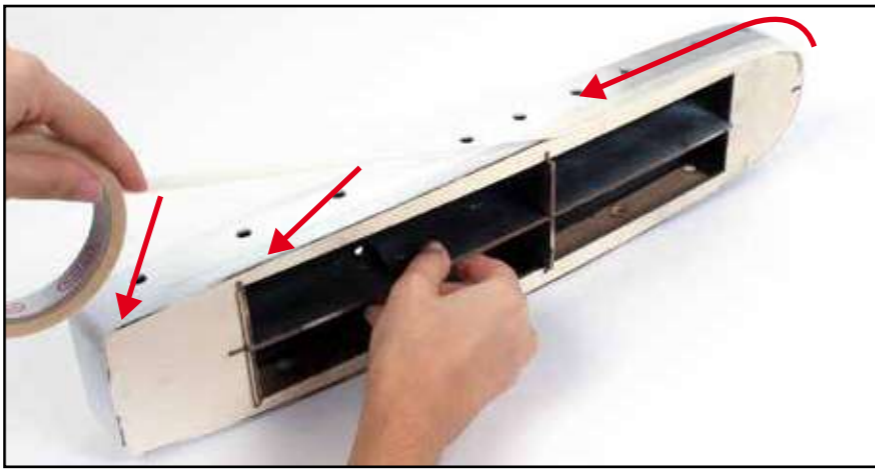
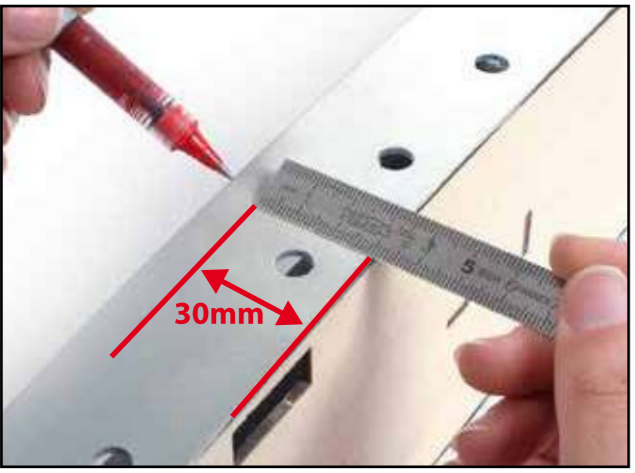
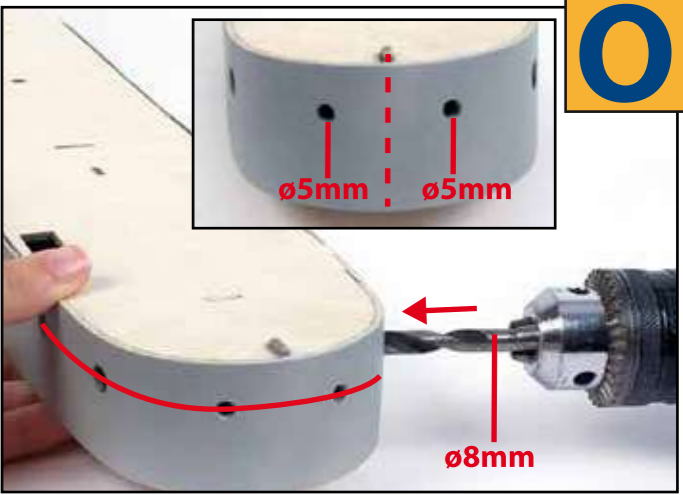
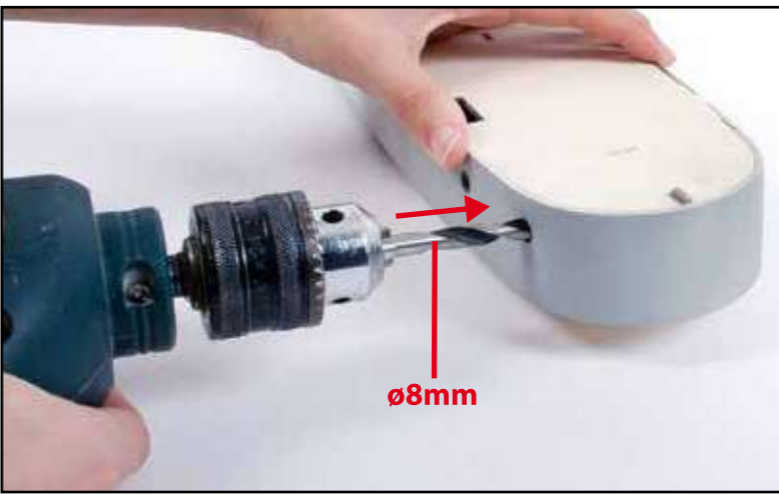
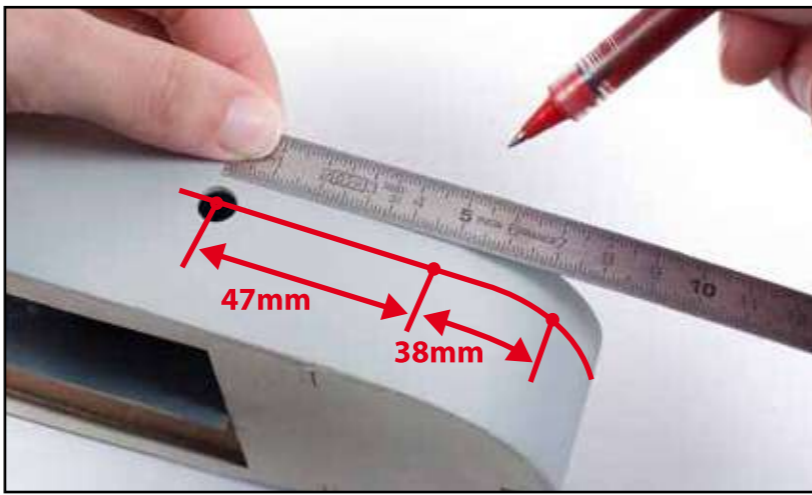
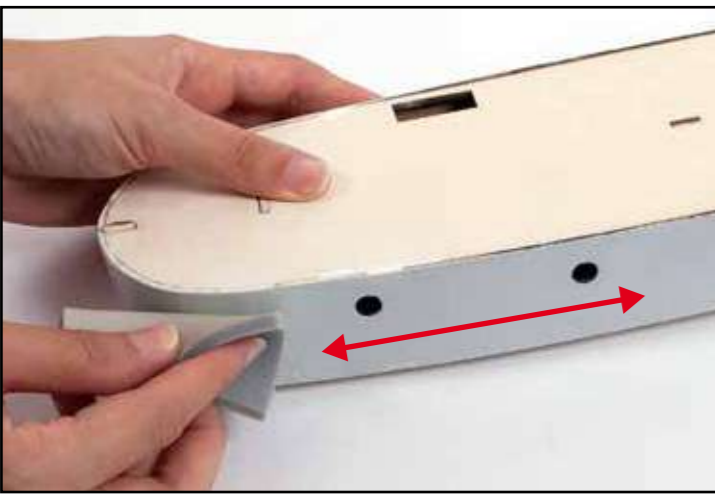

P

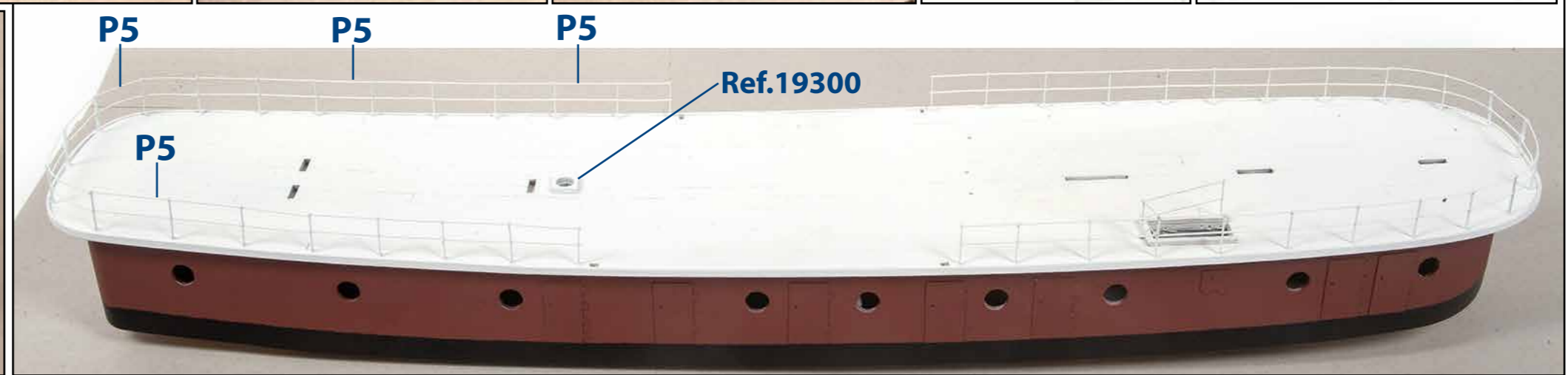
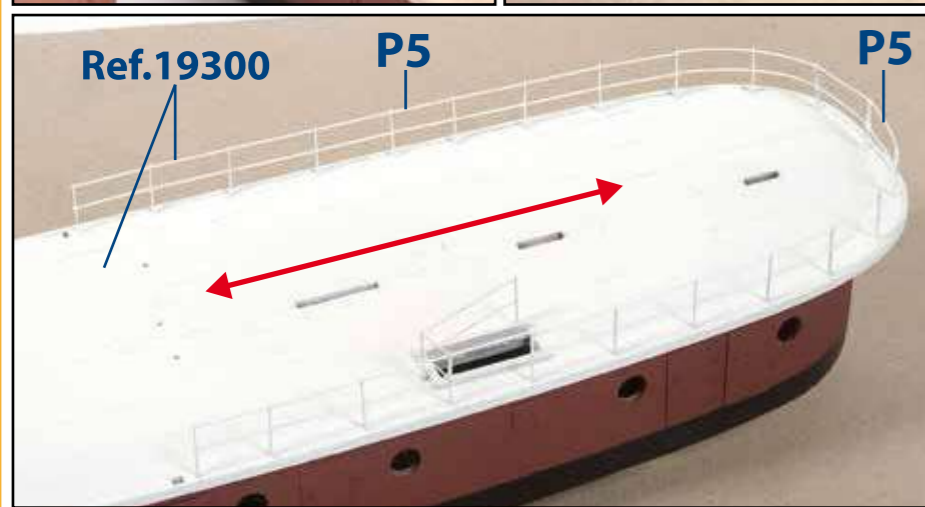
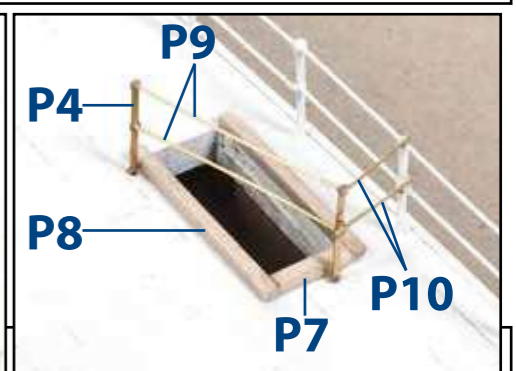
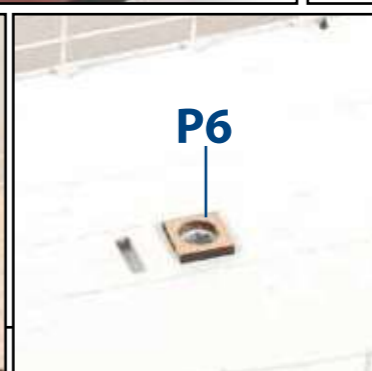
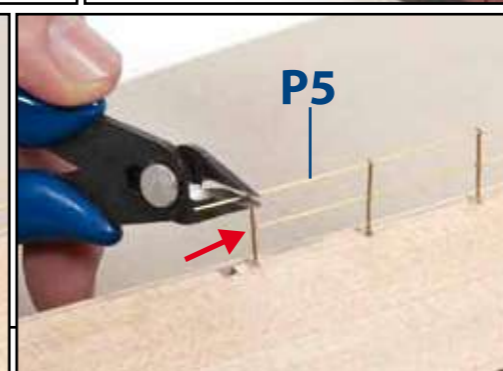
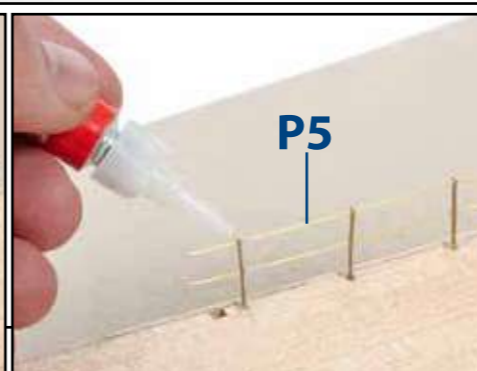
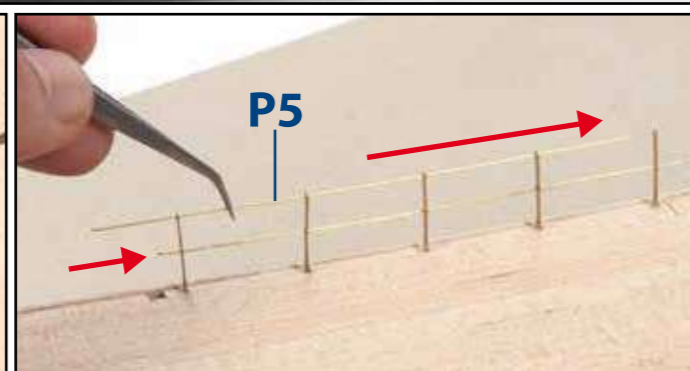
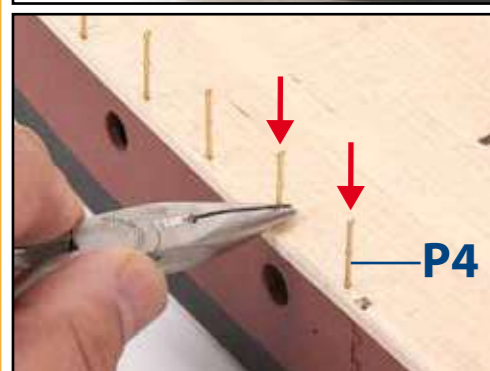
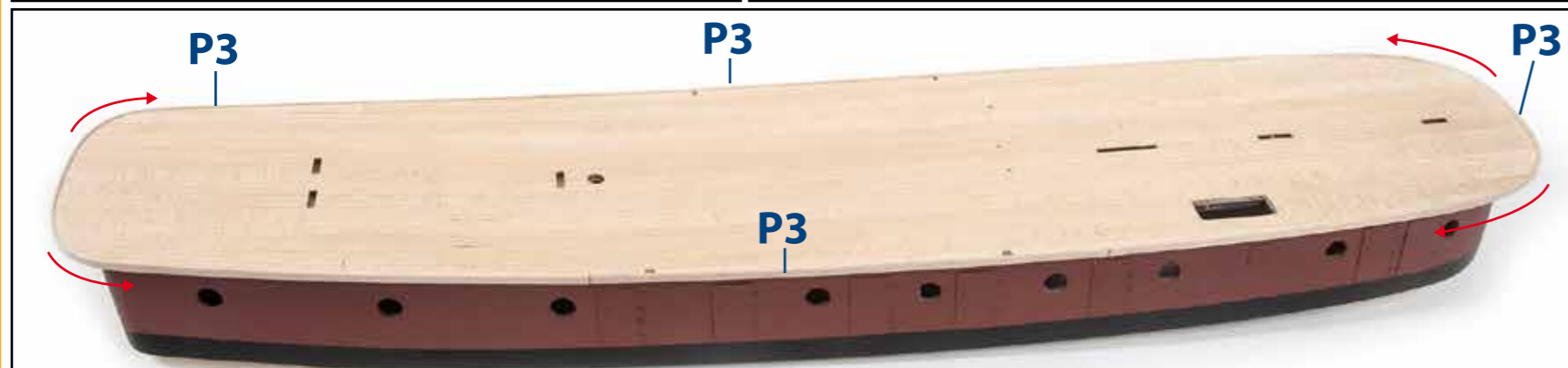
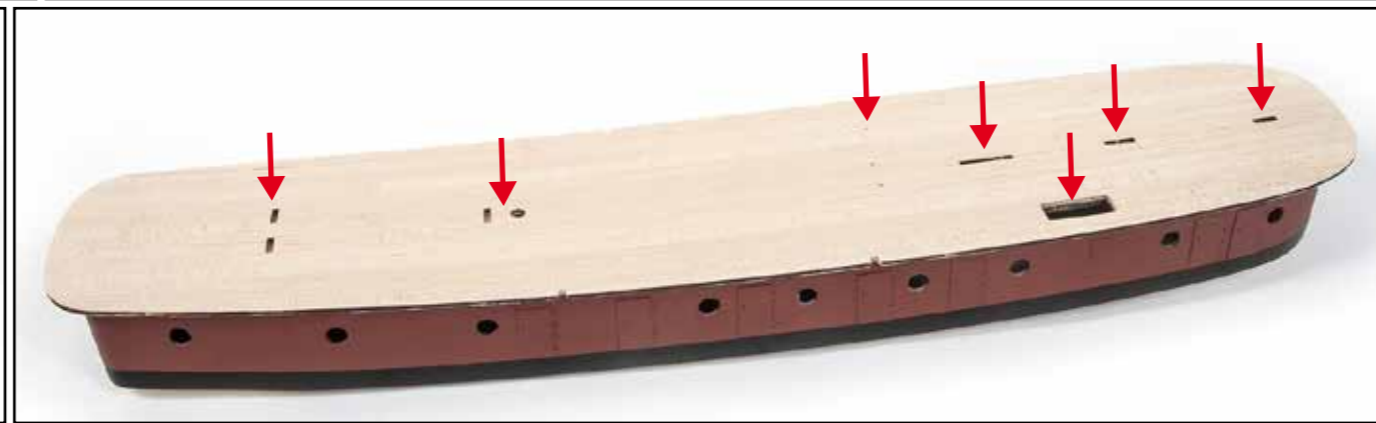
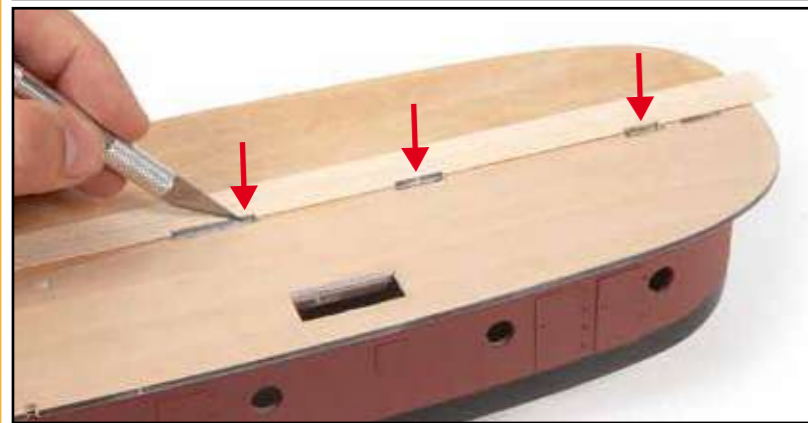
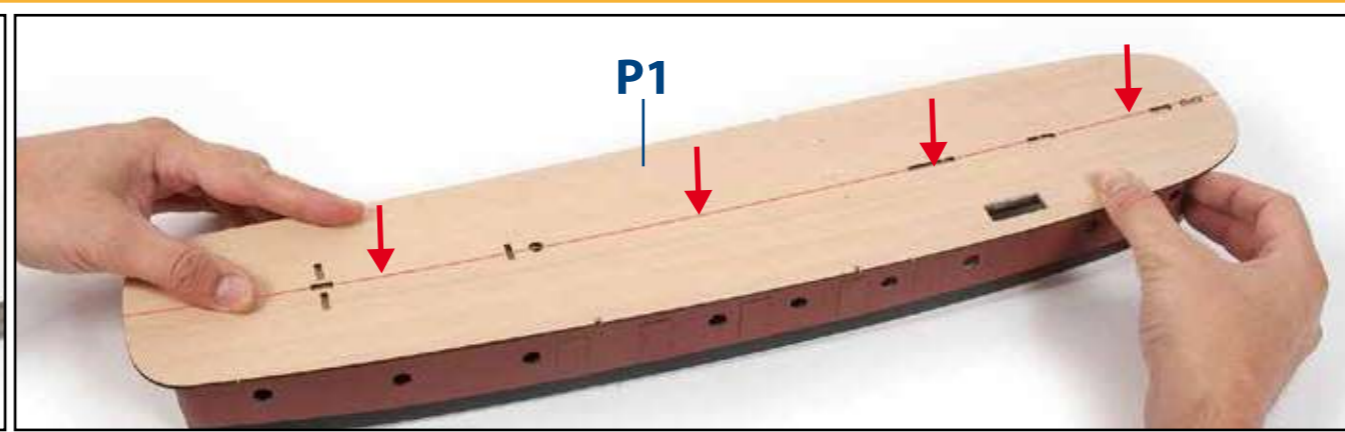
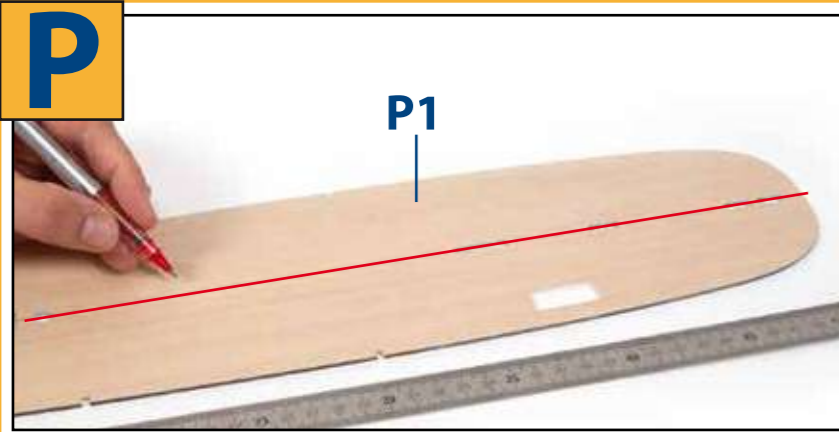

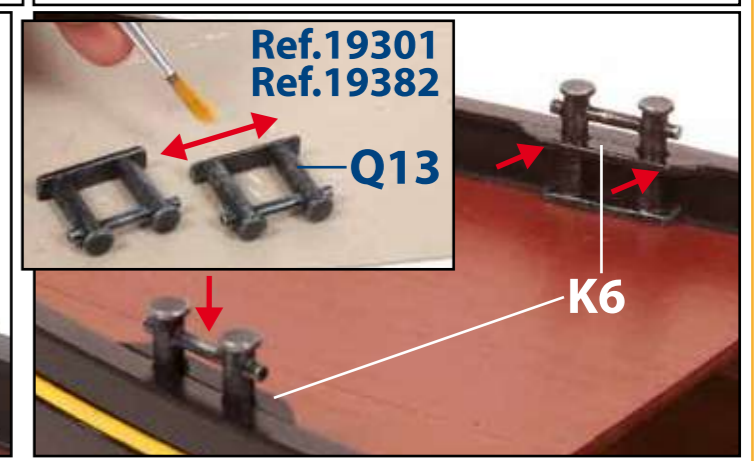
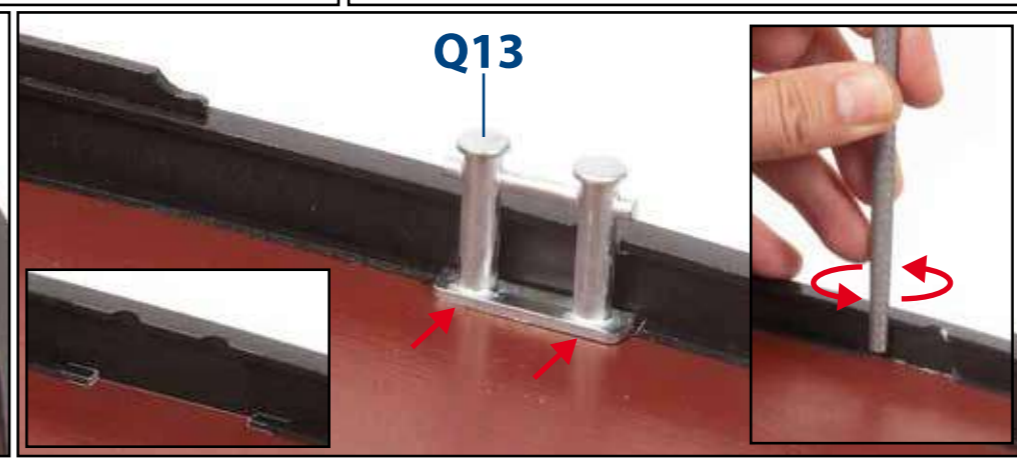
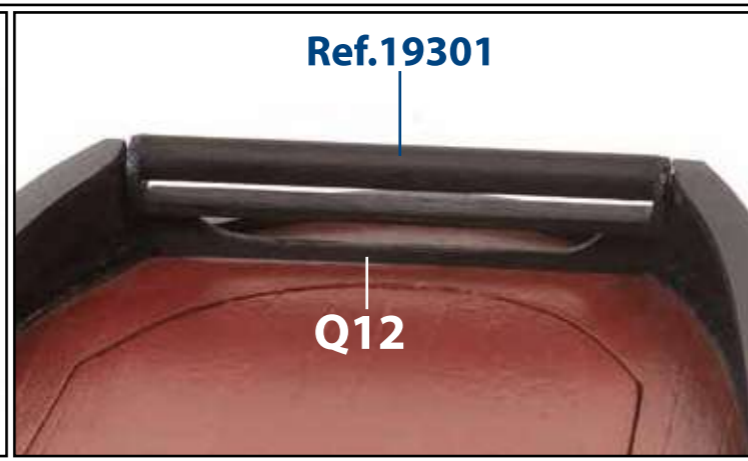
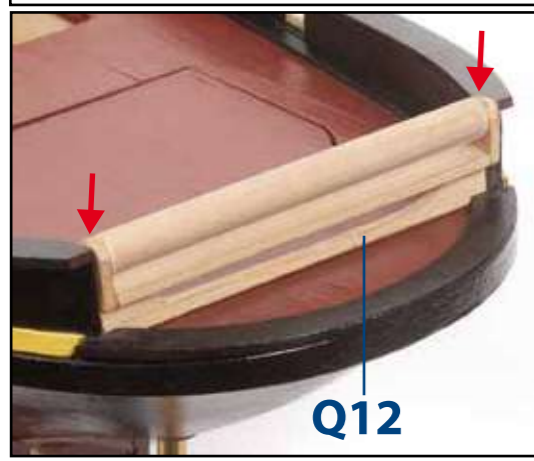
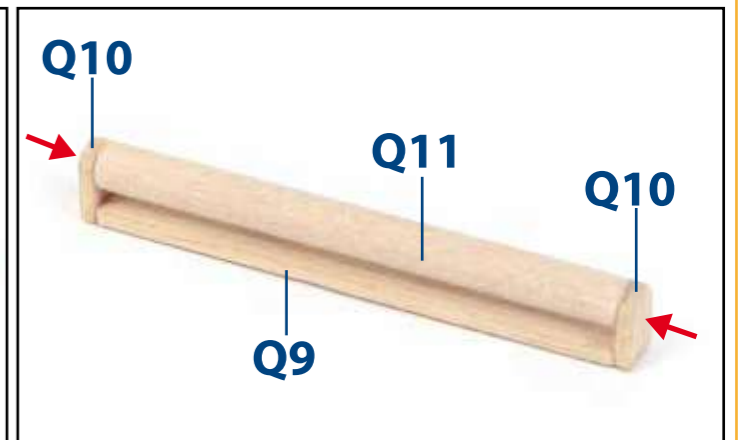
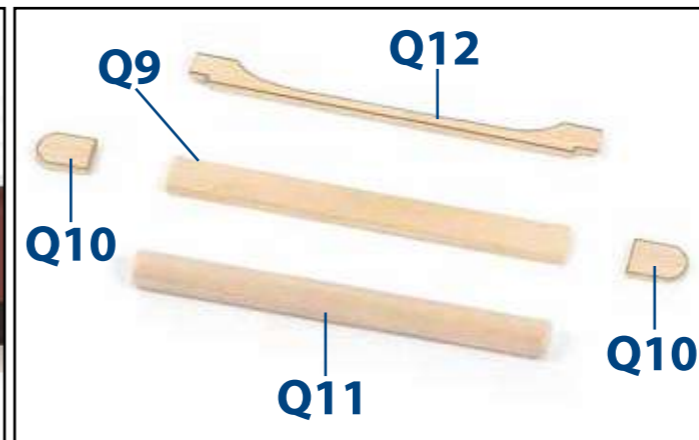
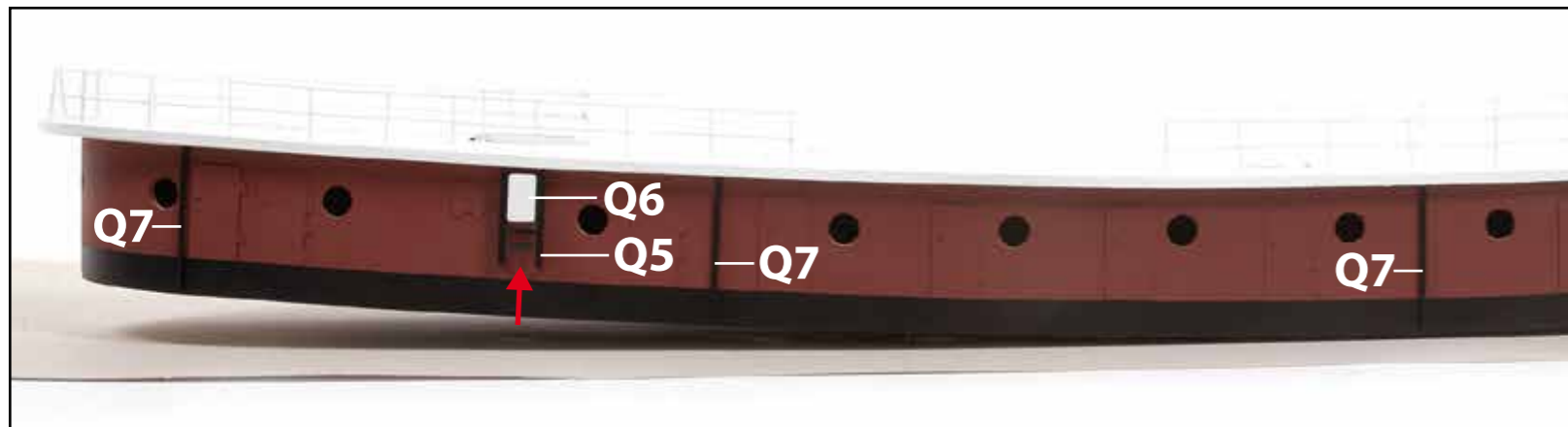
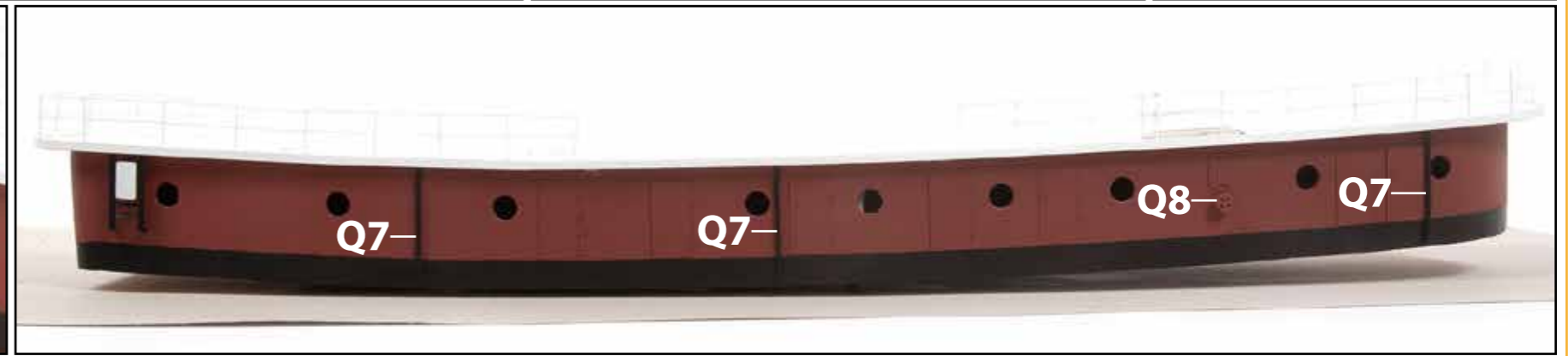
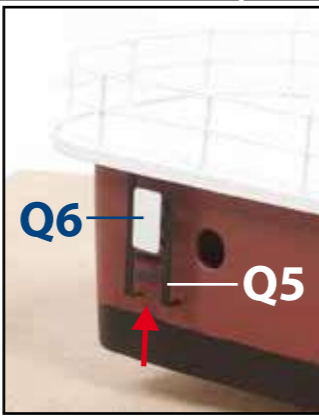
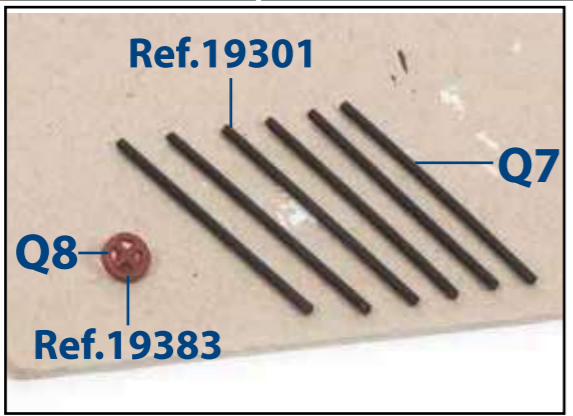
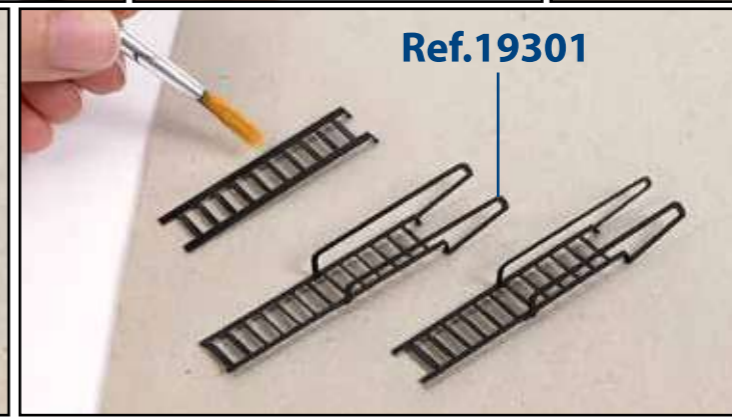
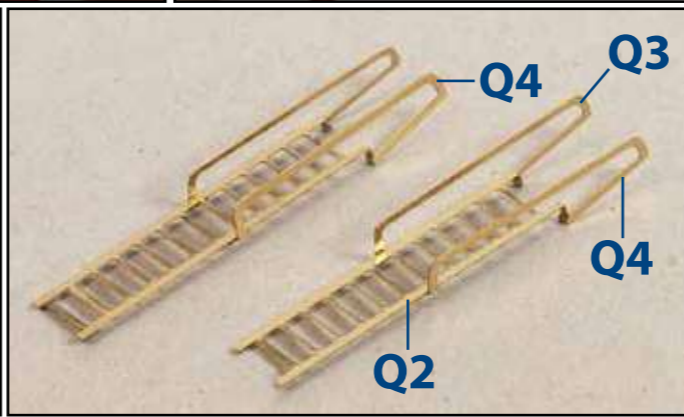
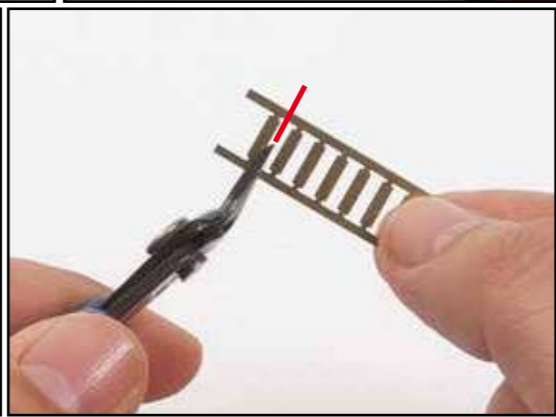
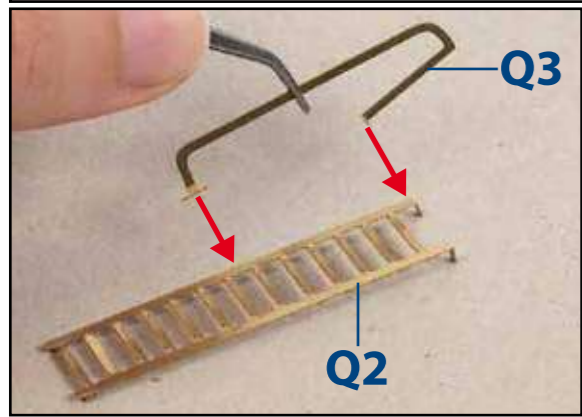
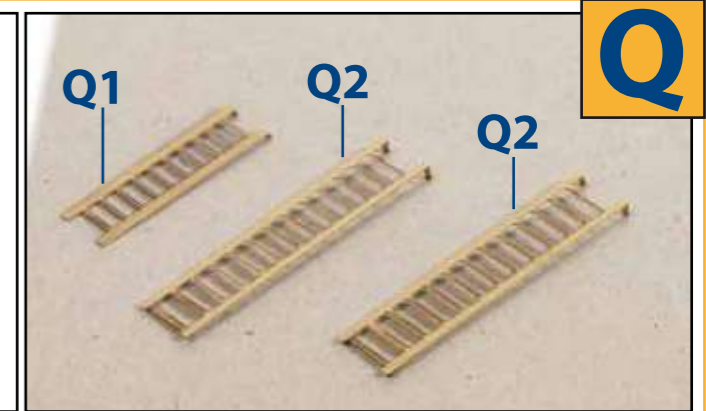
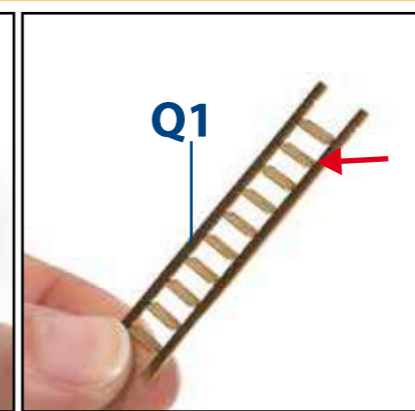
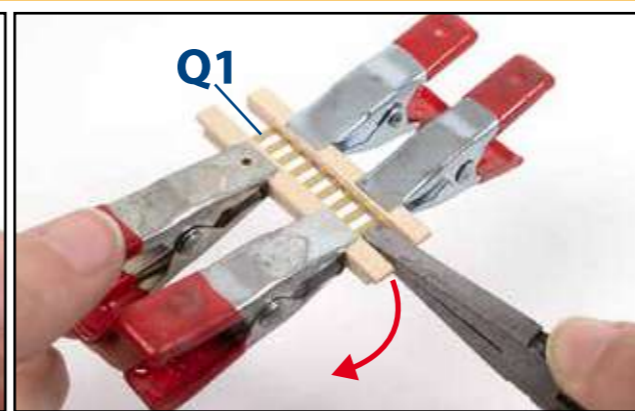
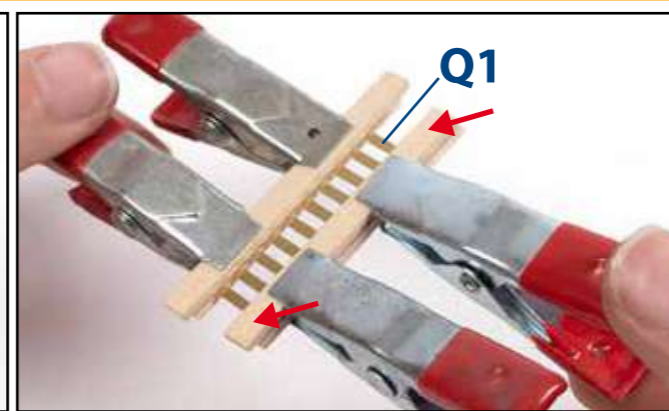
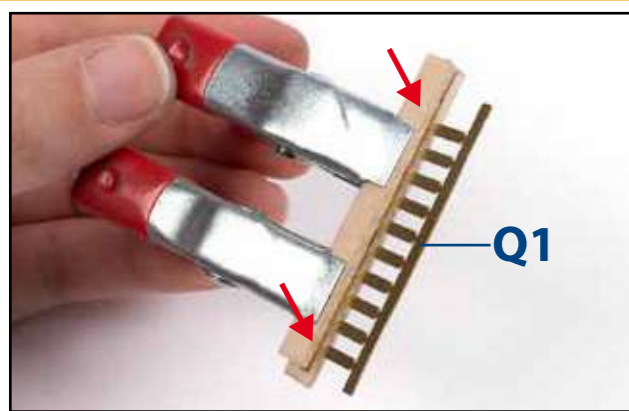

R

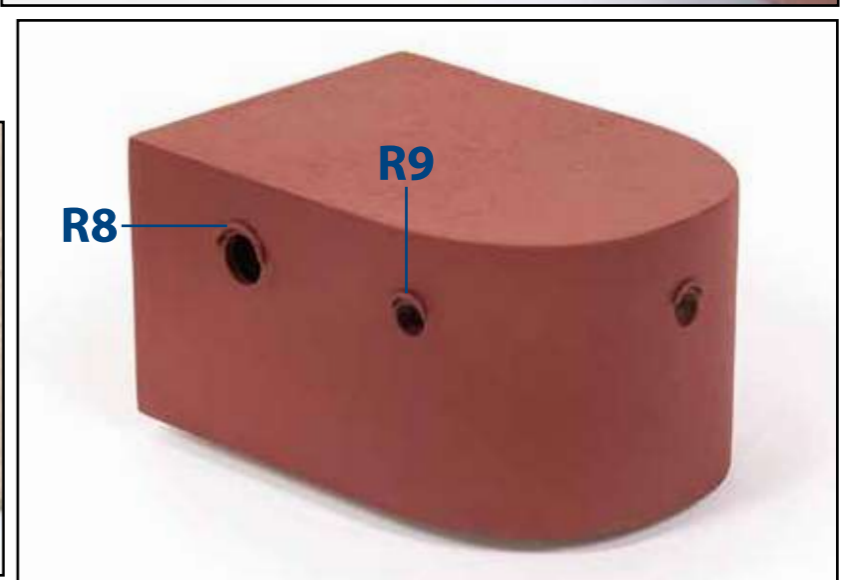
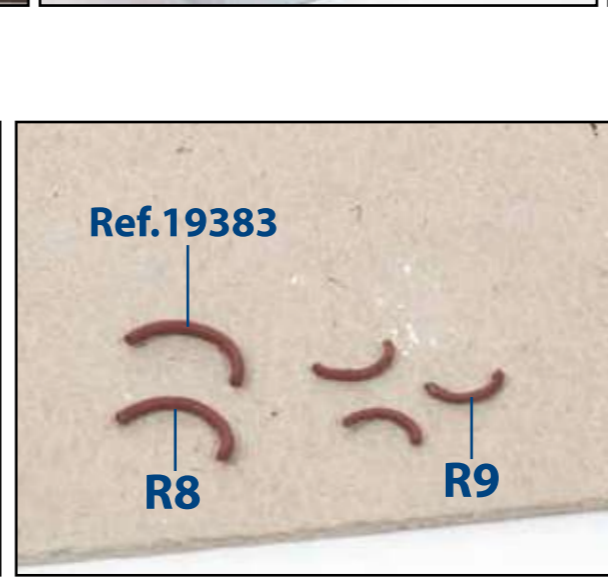
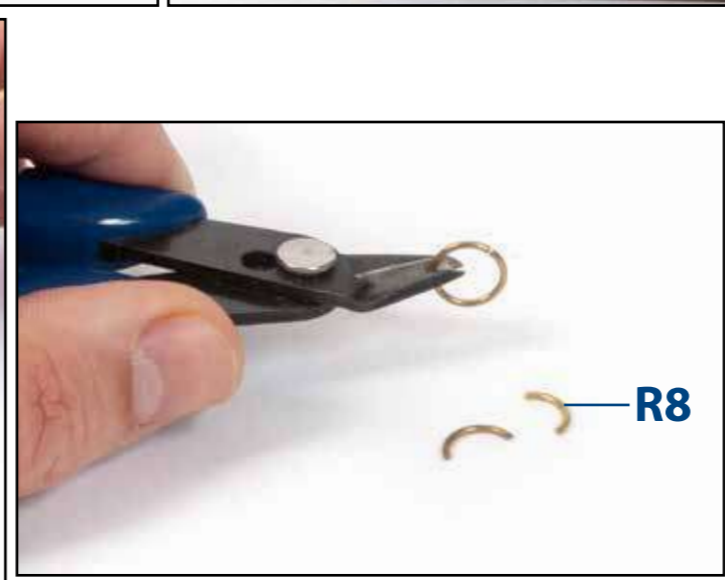
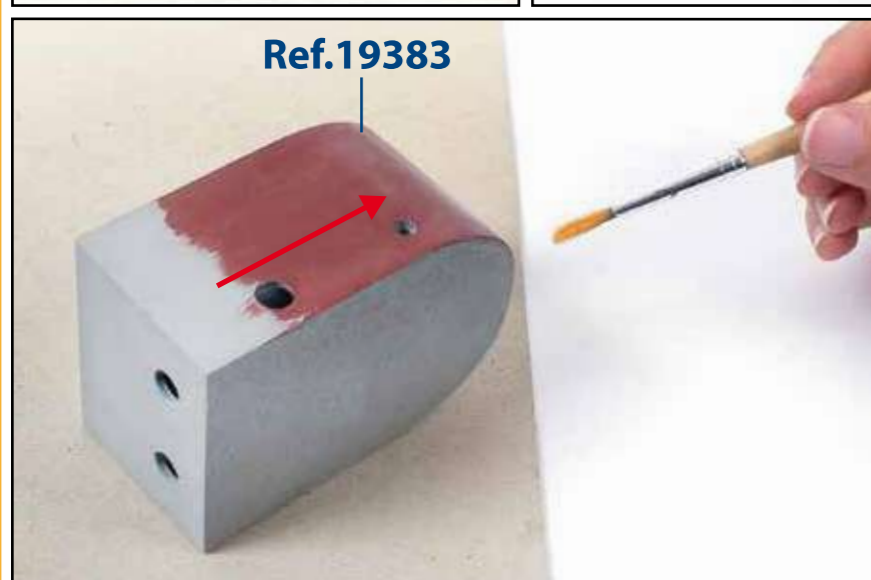
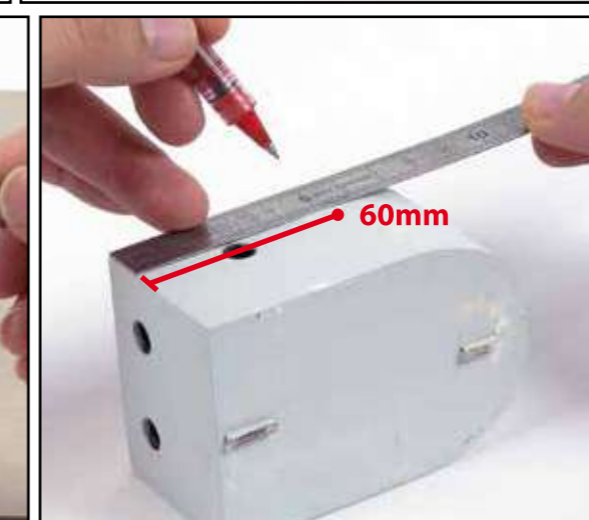
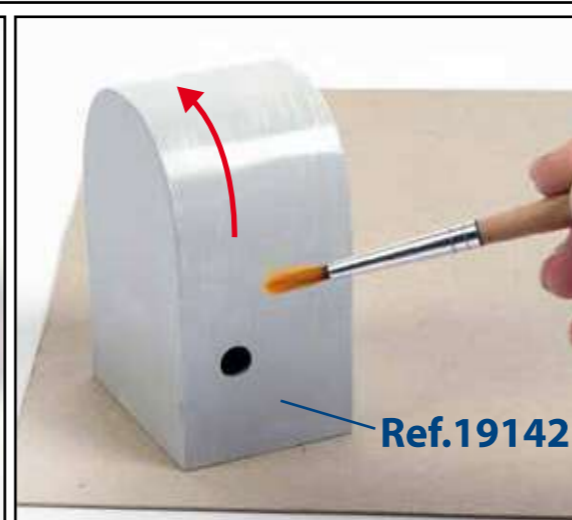
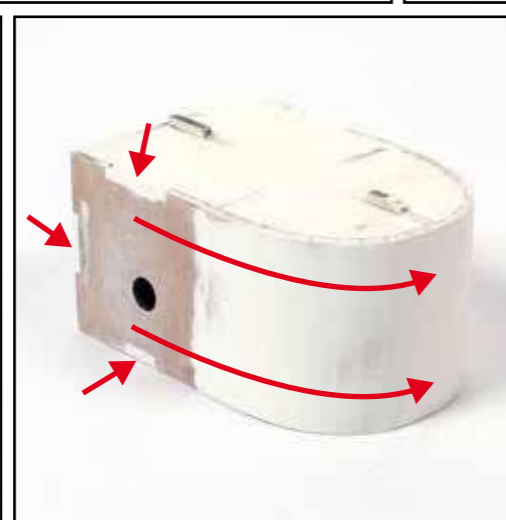
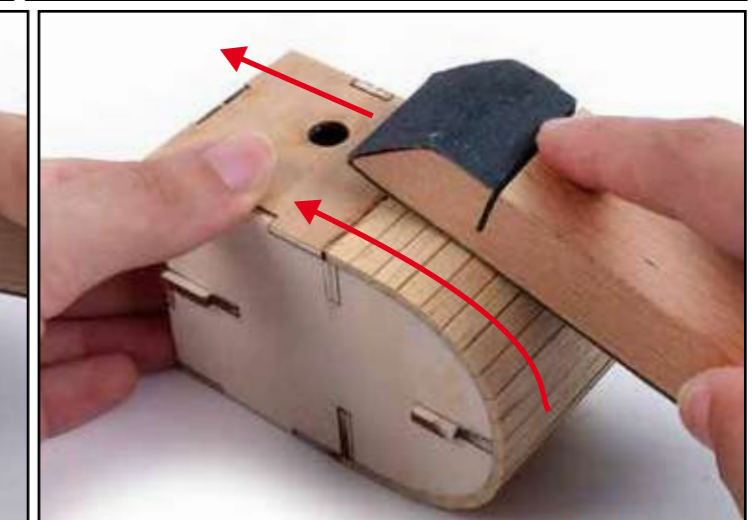
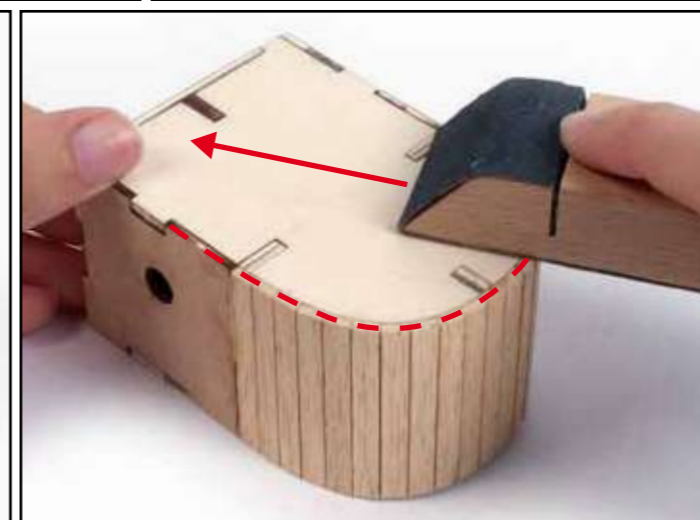
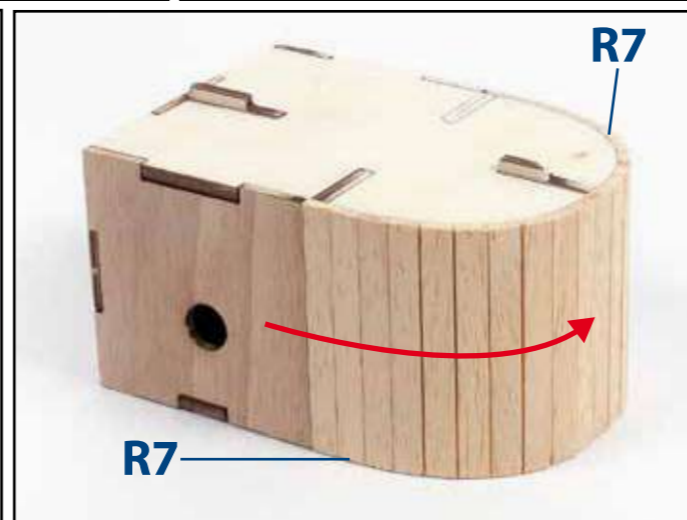
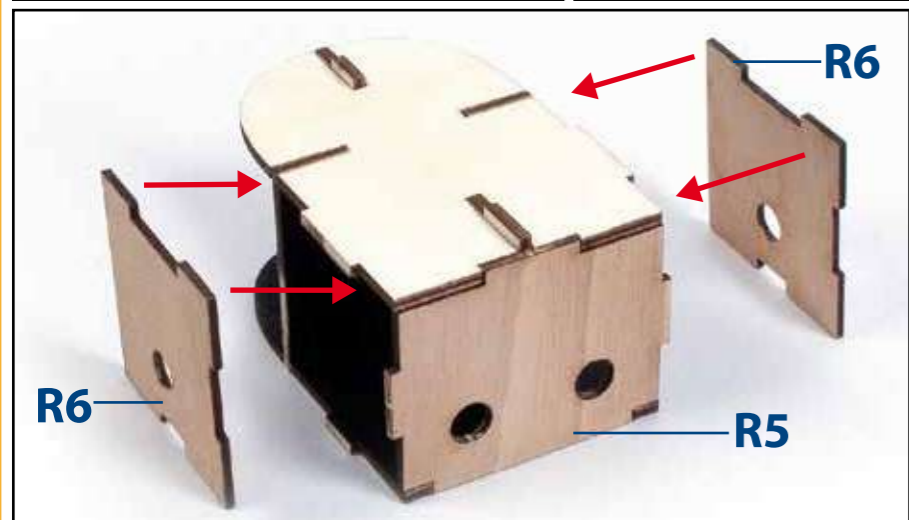
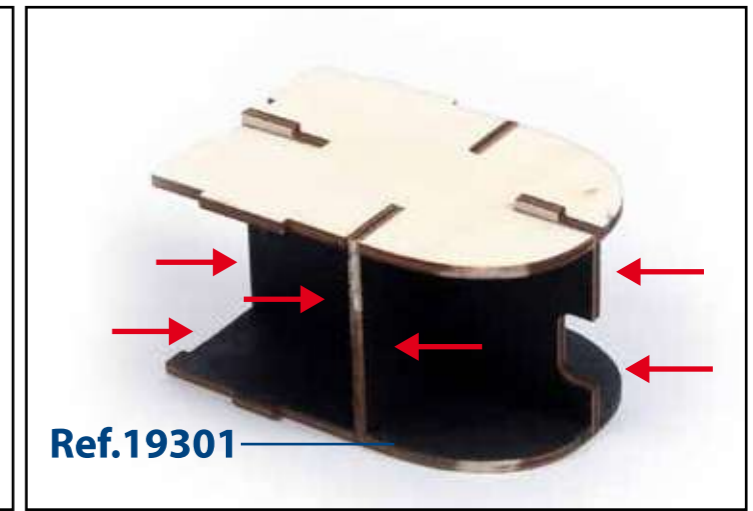
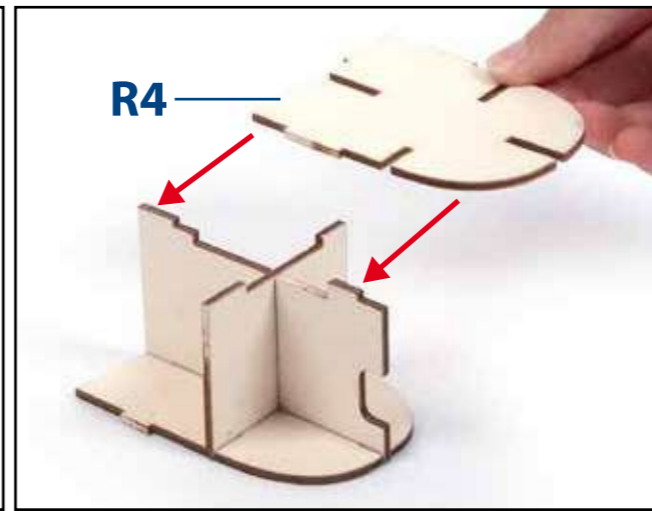
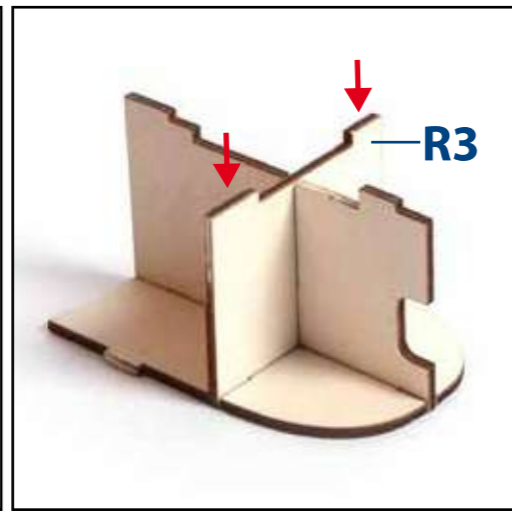
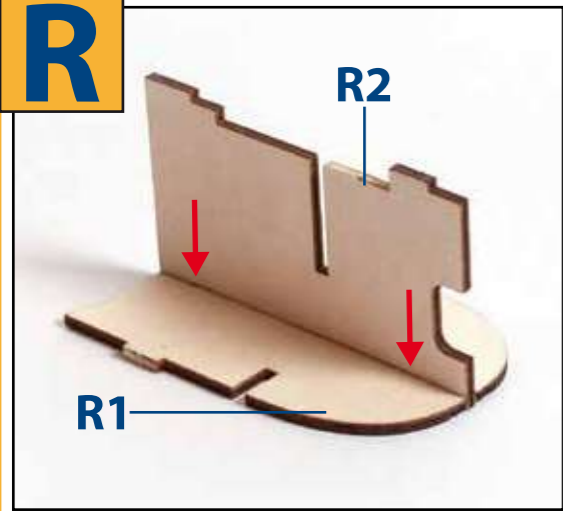

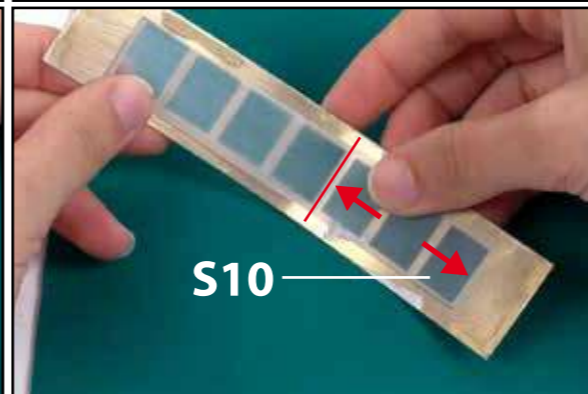
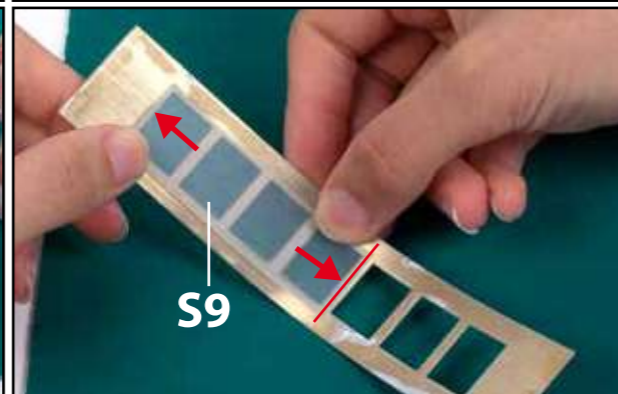
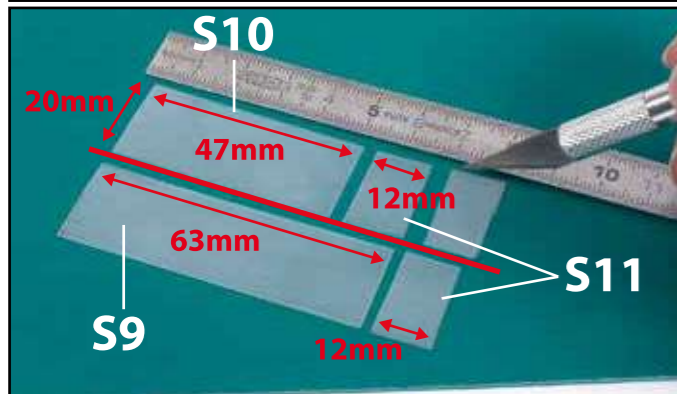
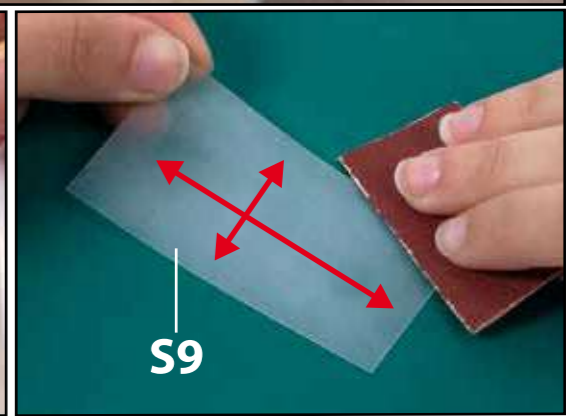
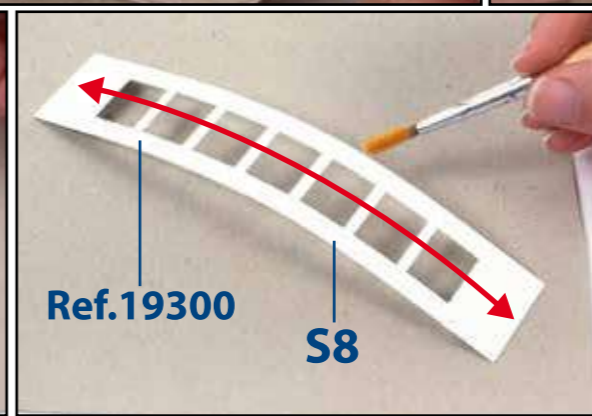
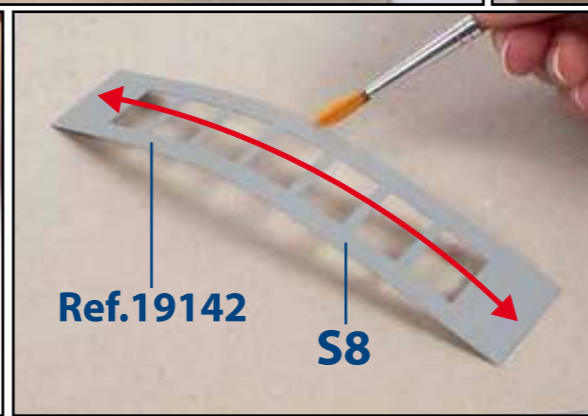
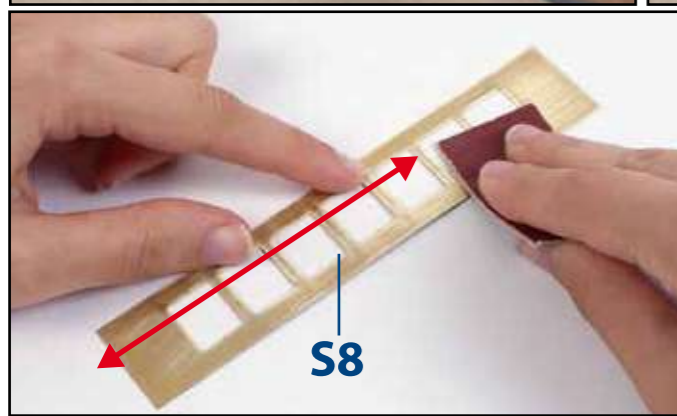
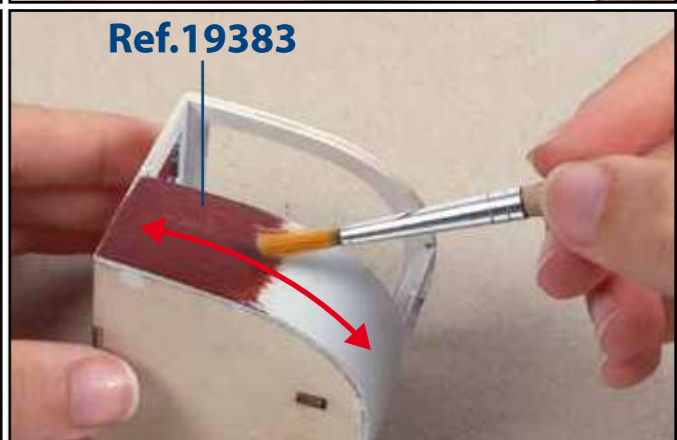
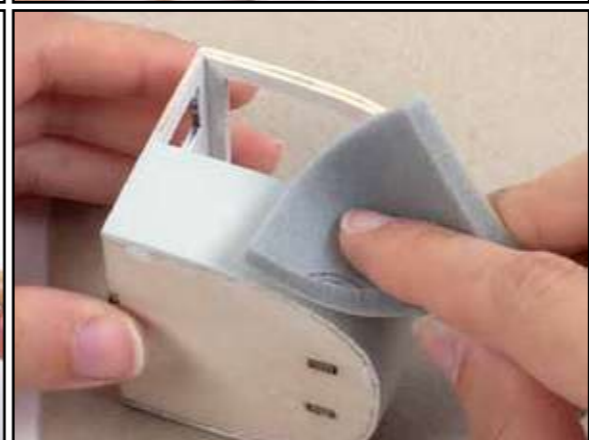
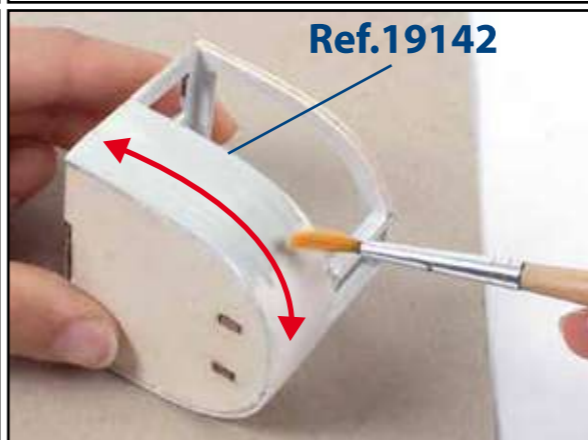
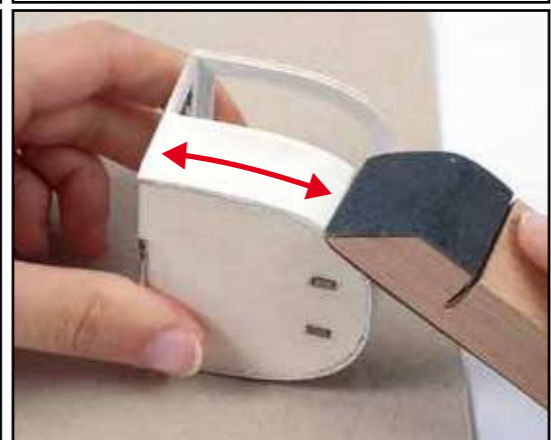
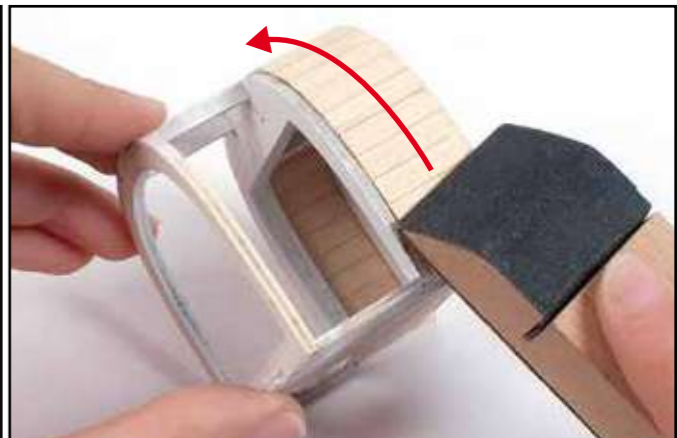
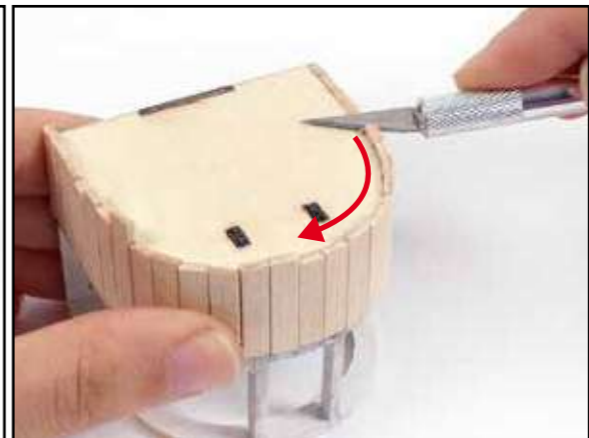
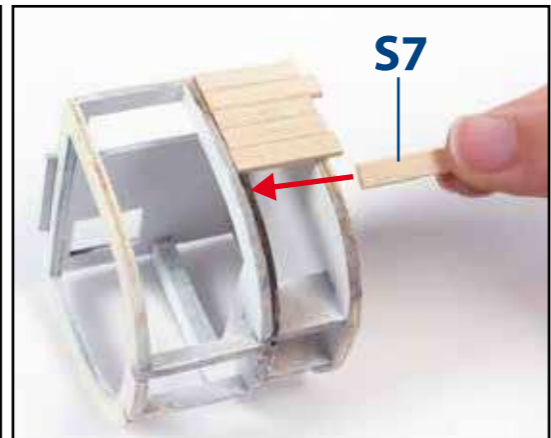
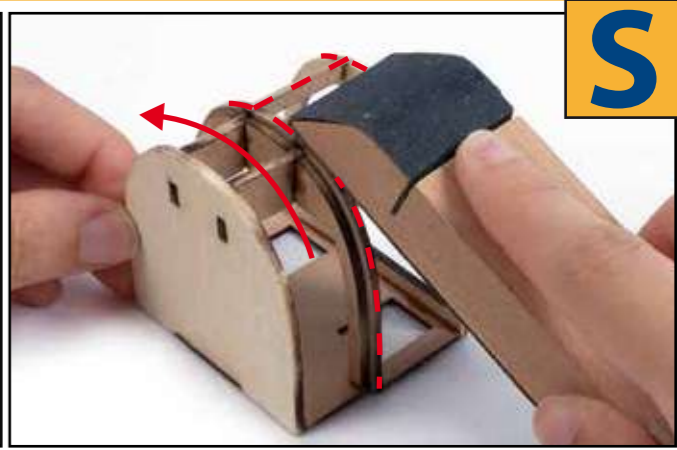
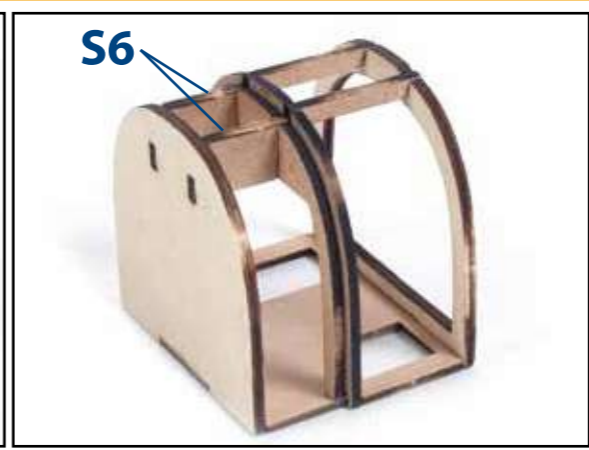
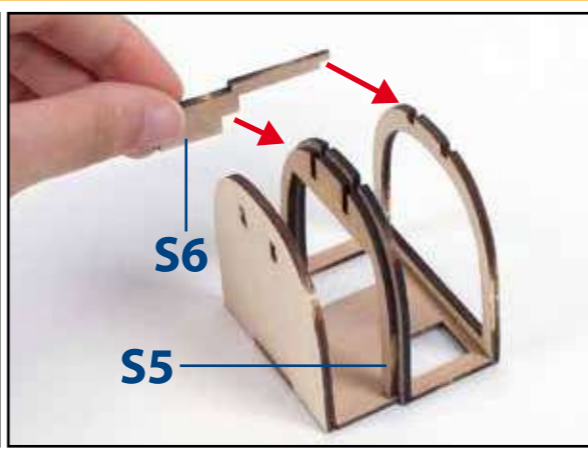
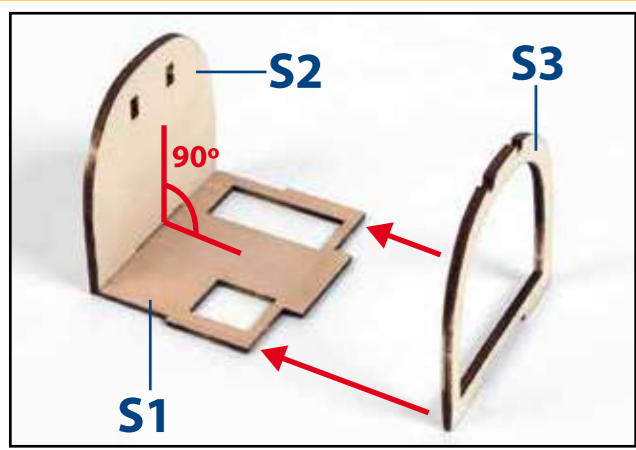

T

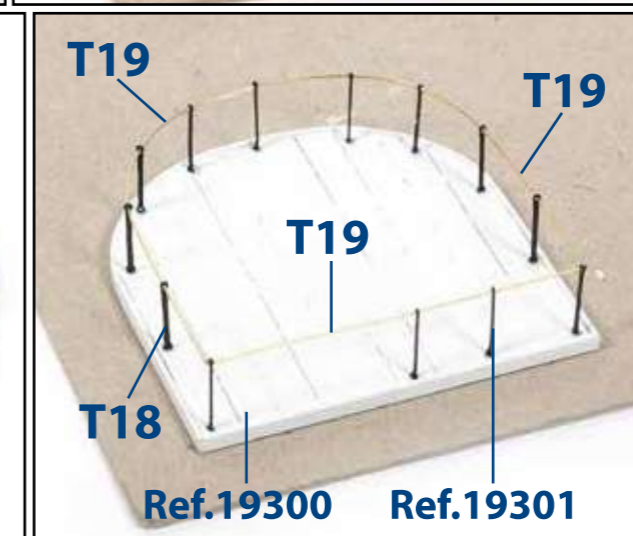
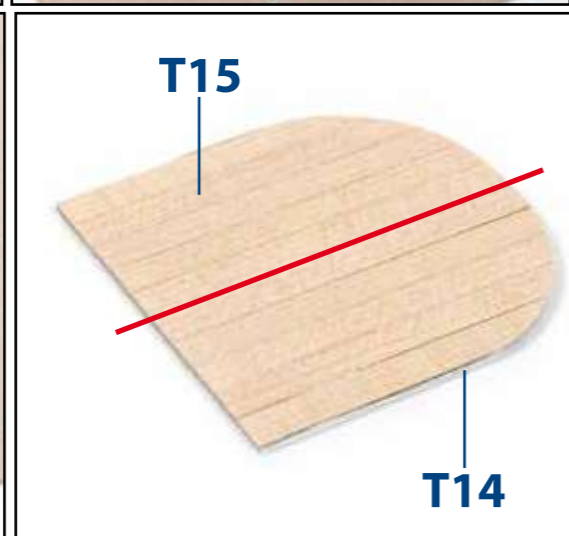
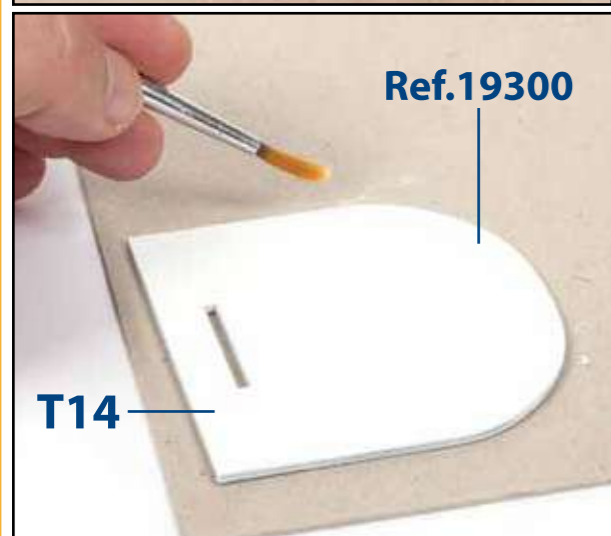
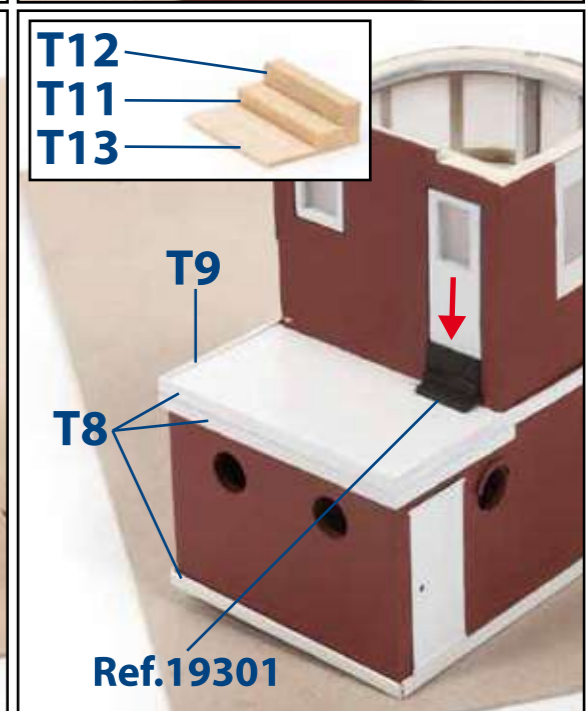
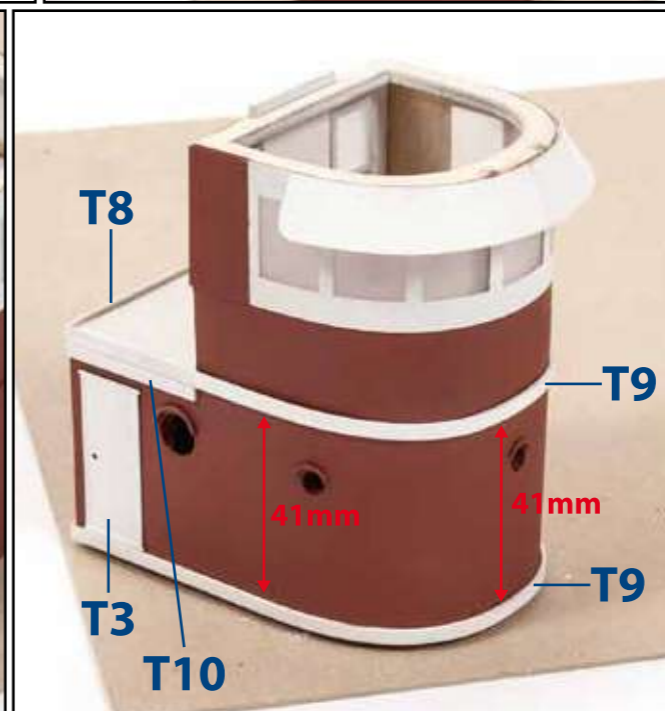
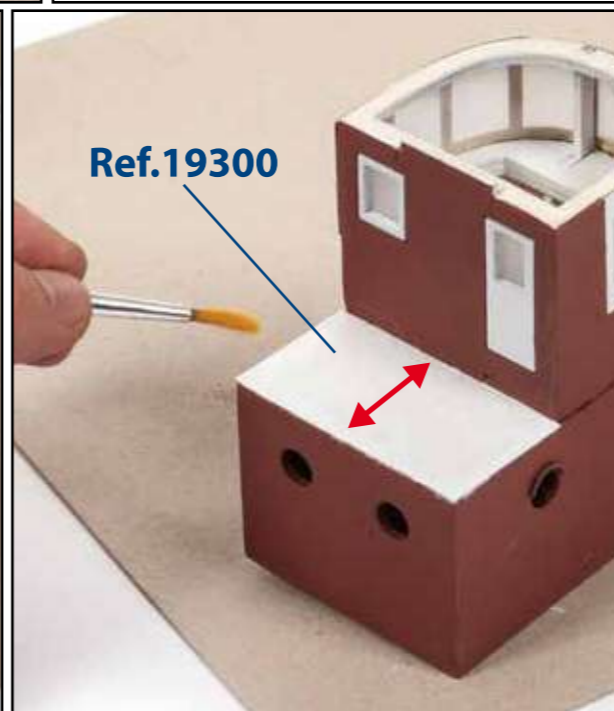
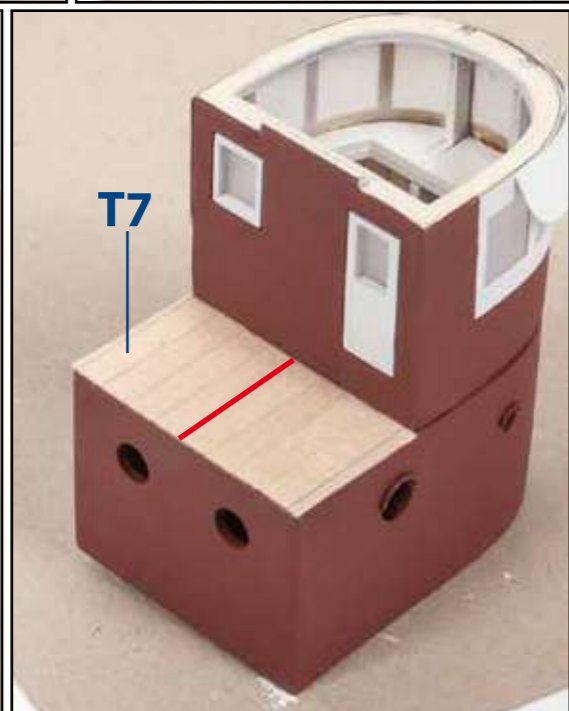
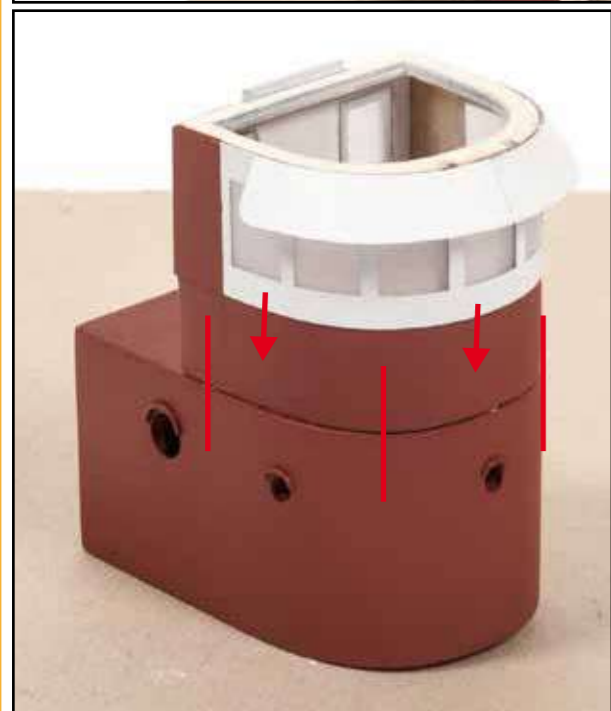
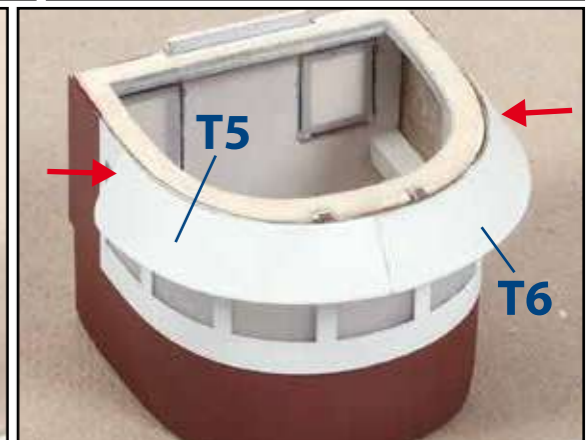
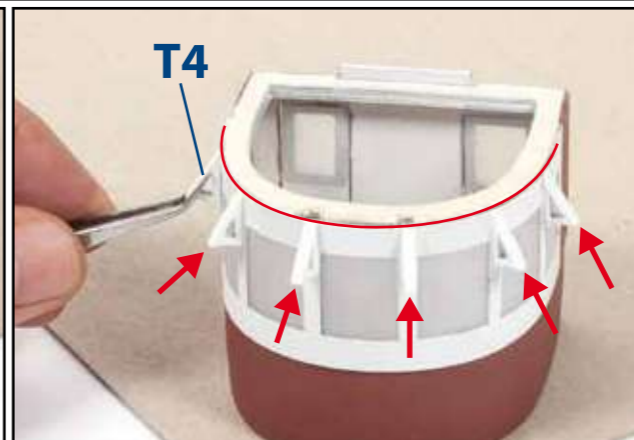
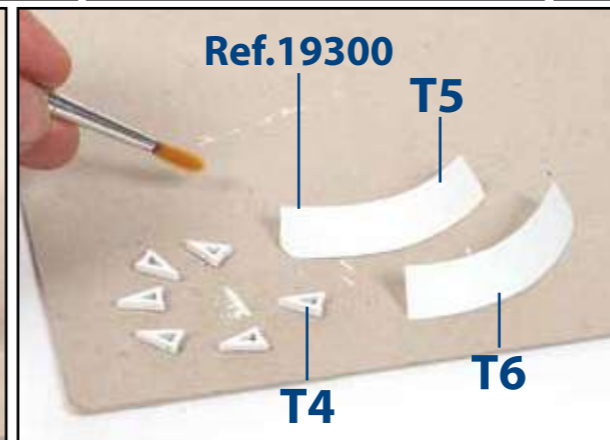
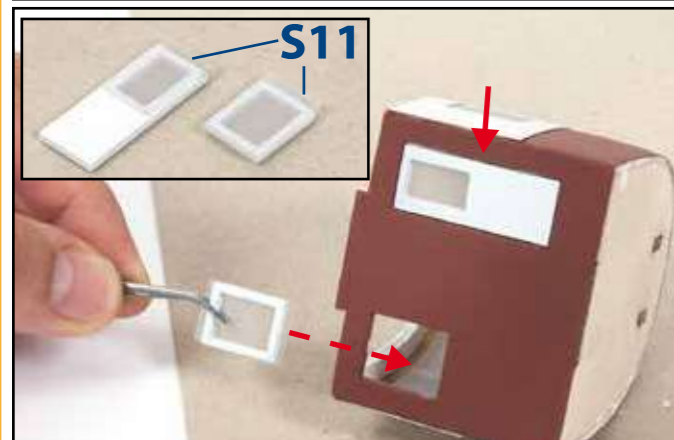
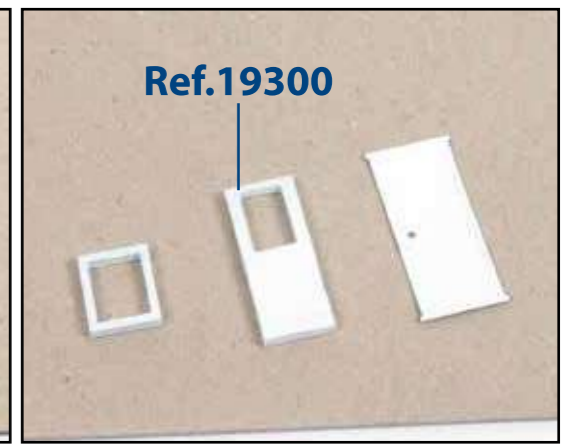
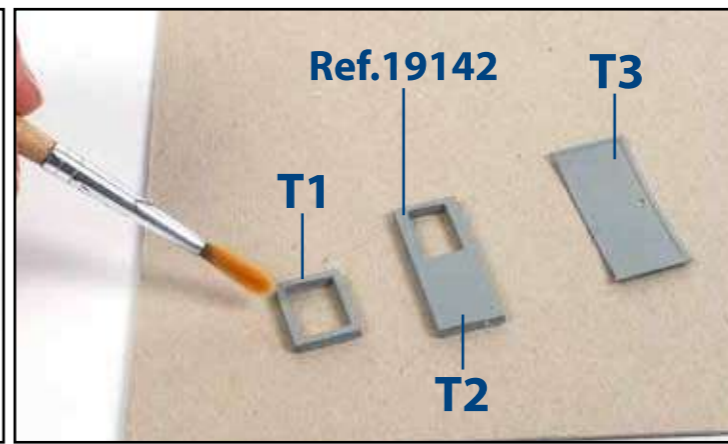
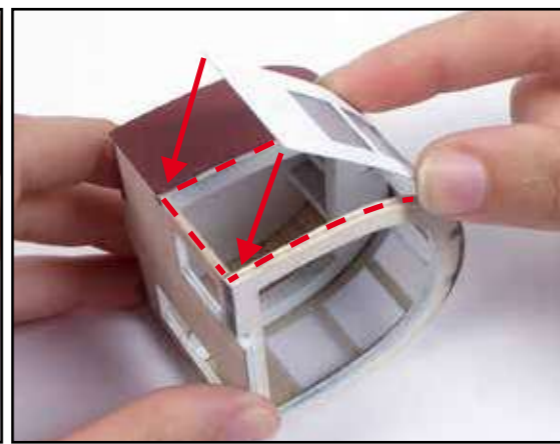
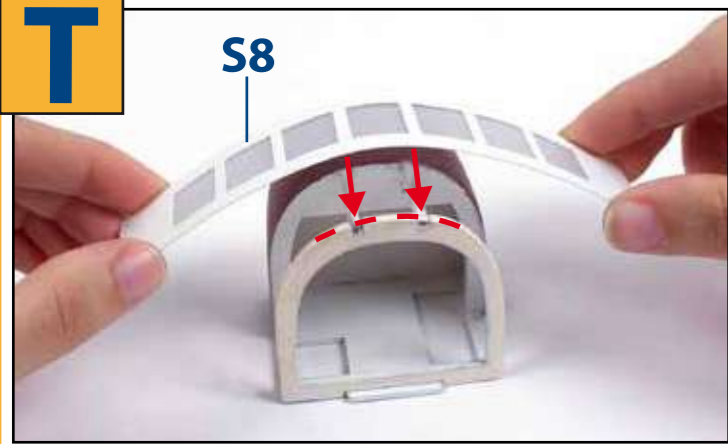

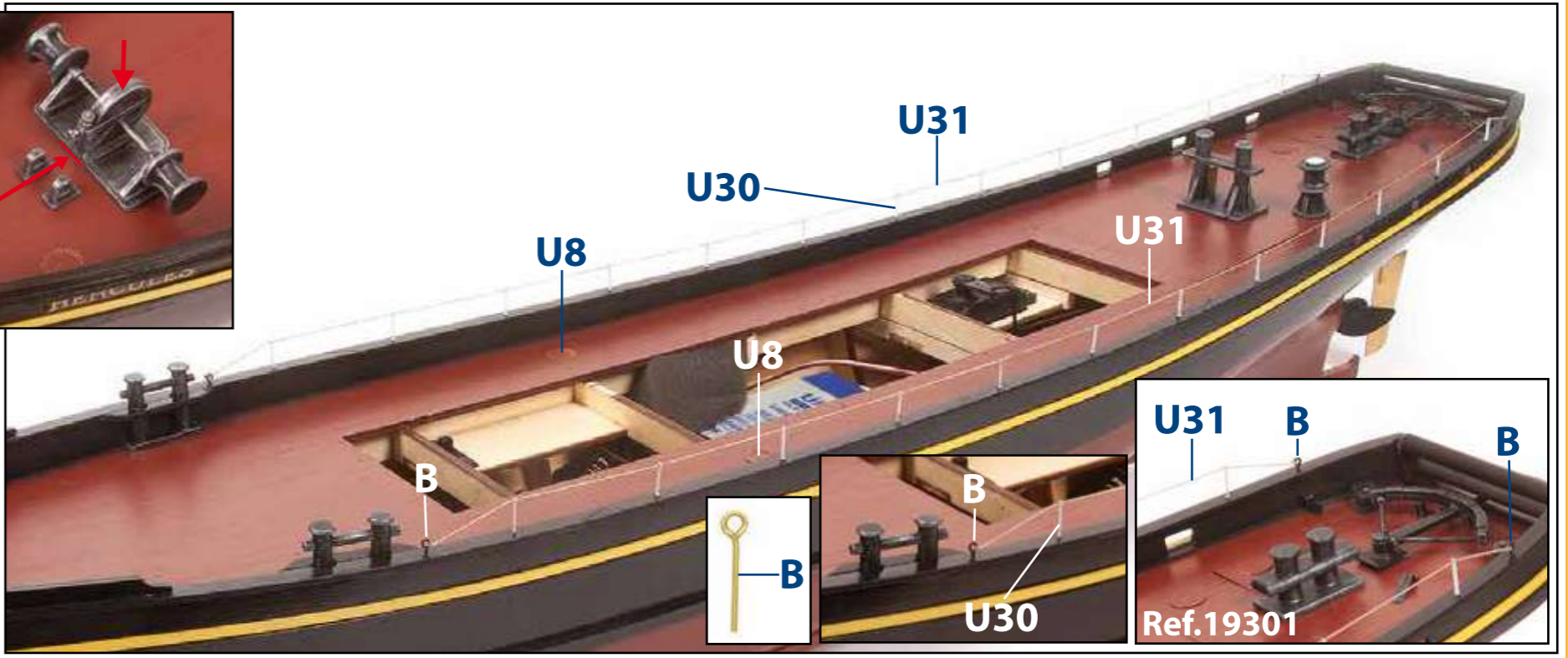
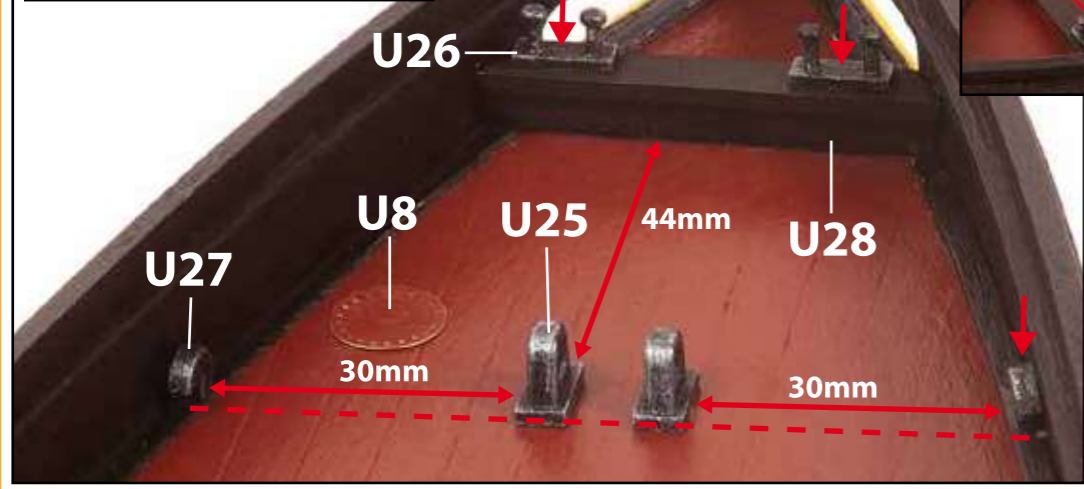
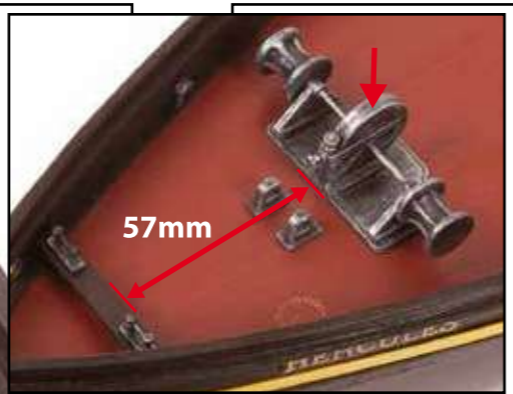
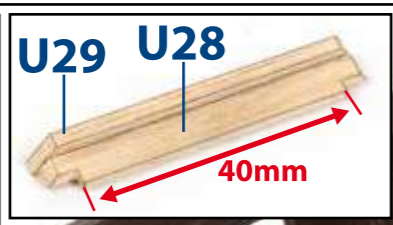
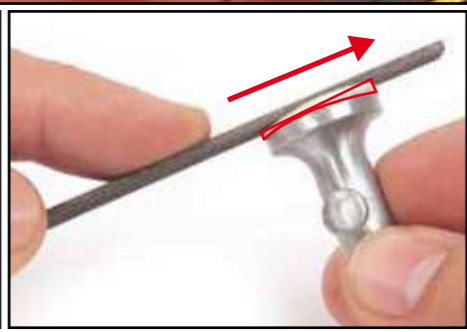
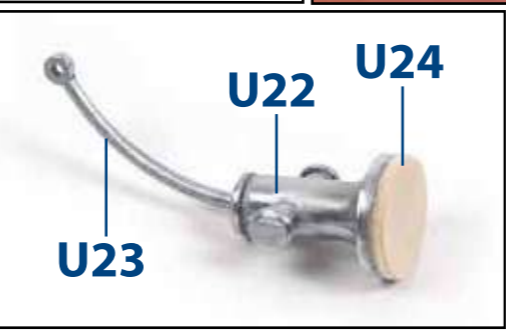
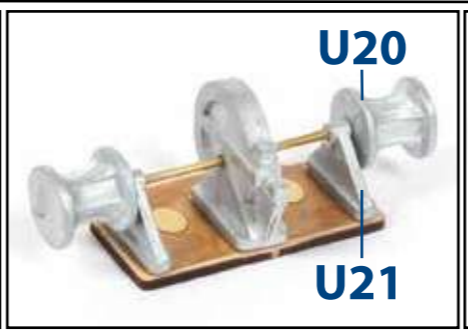
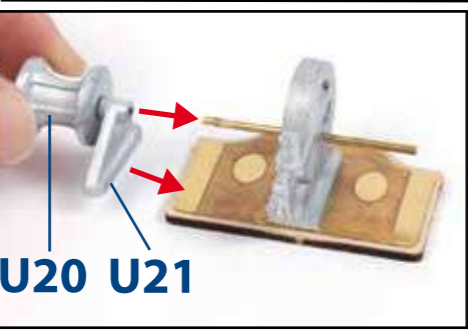
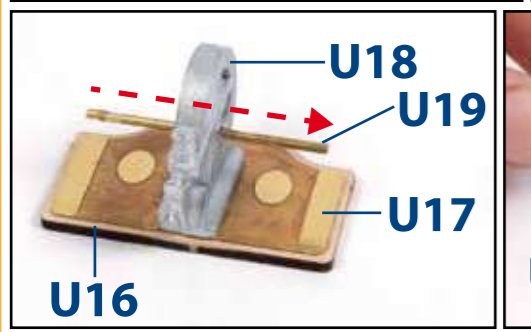
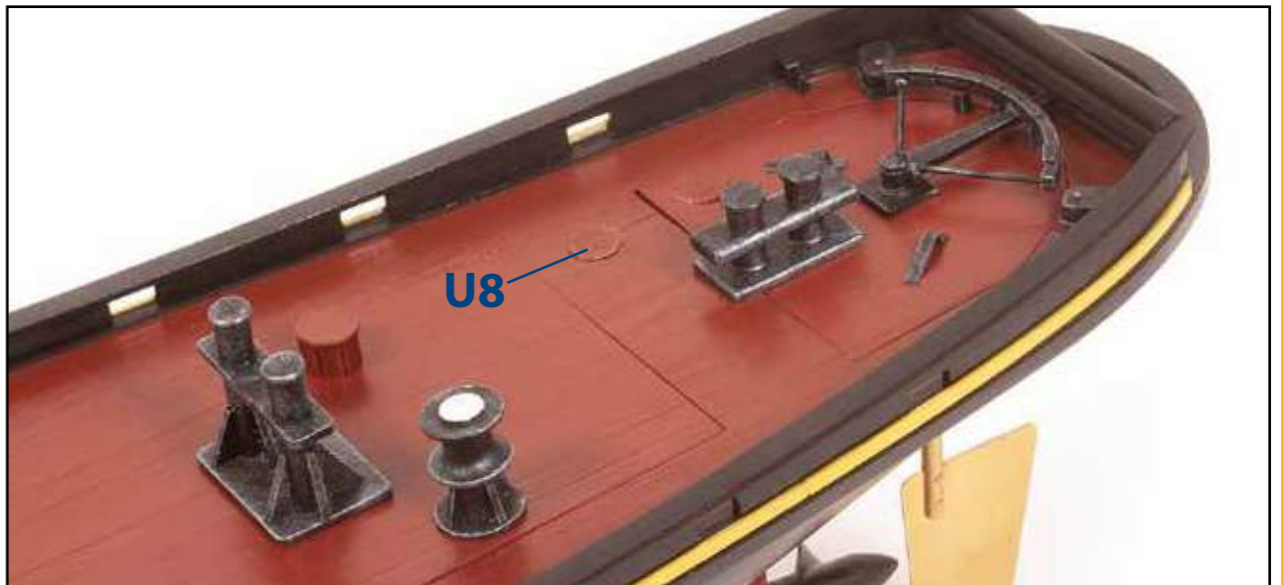
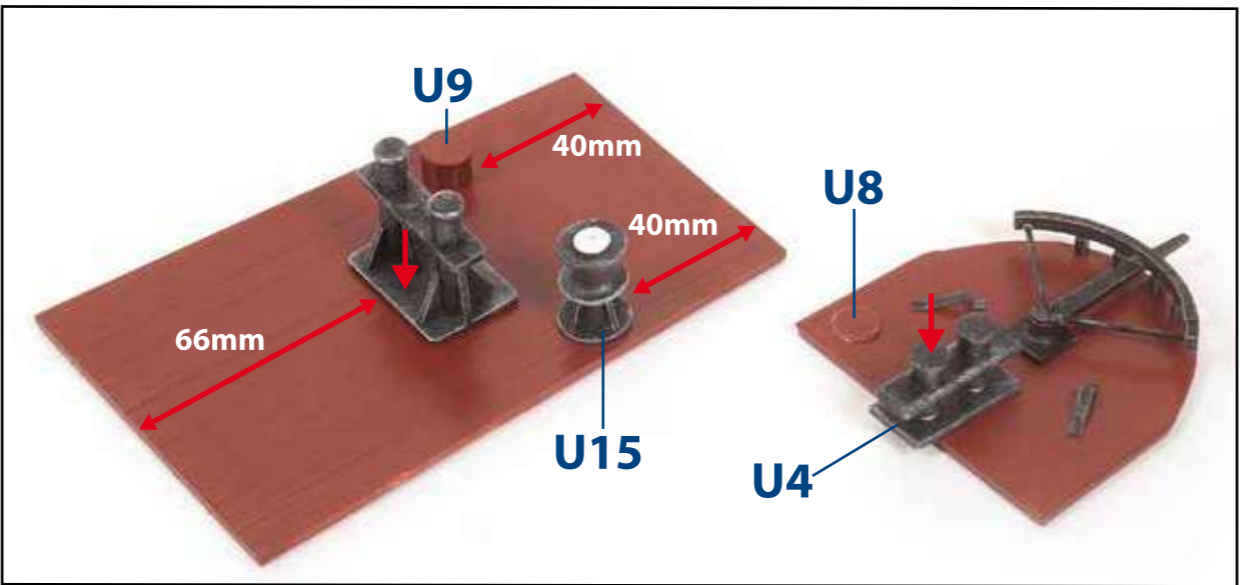
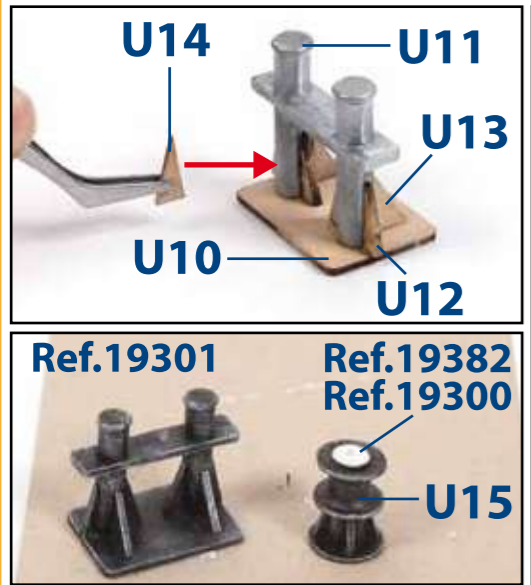
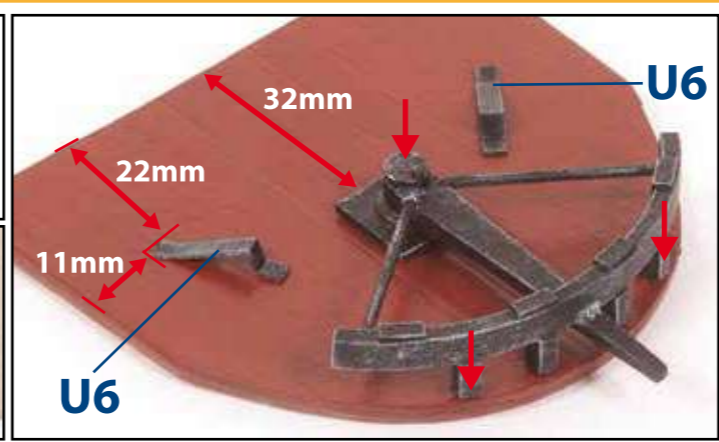
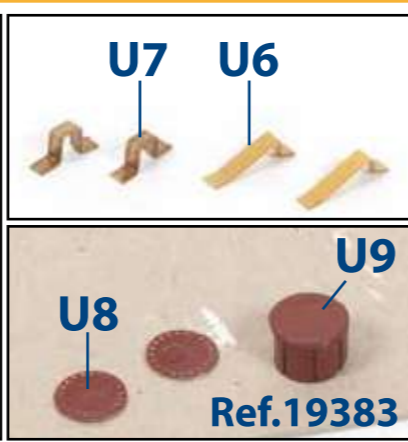
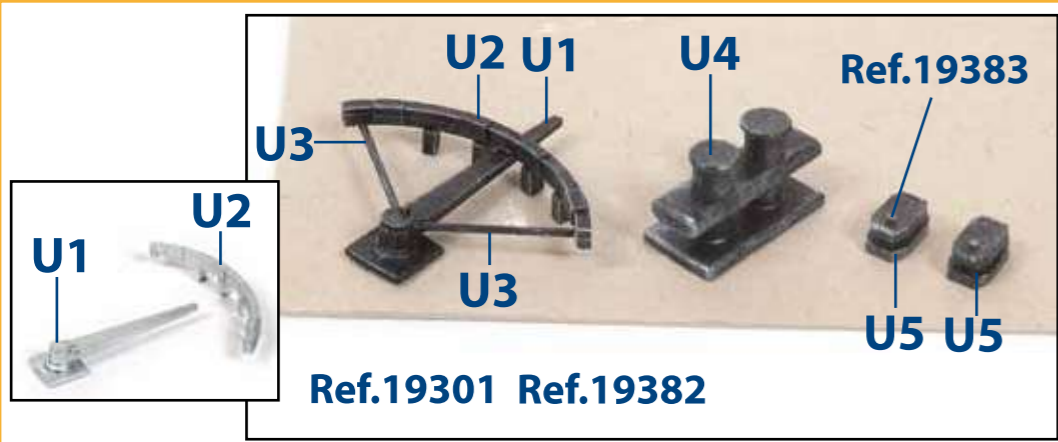

V

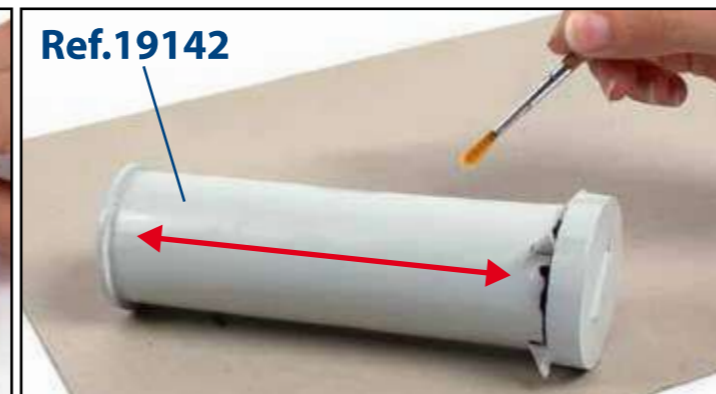
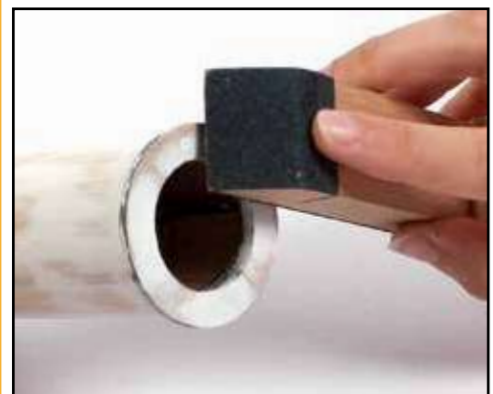
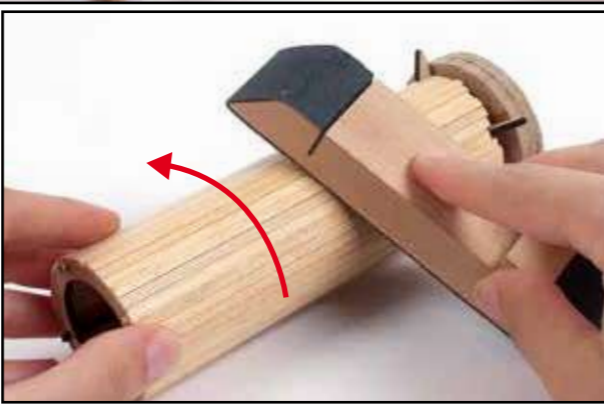
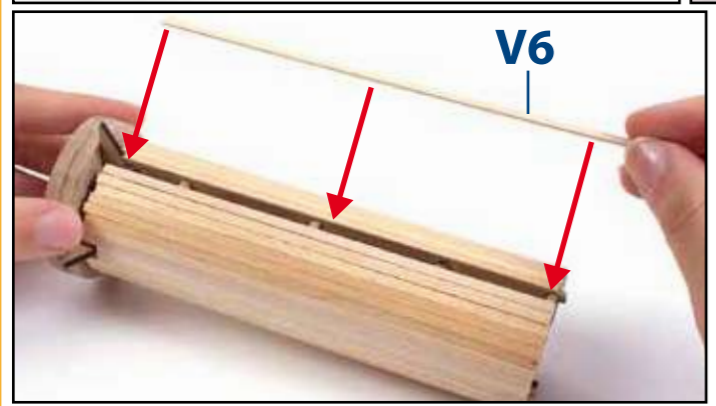
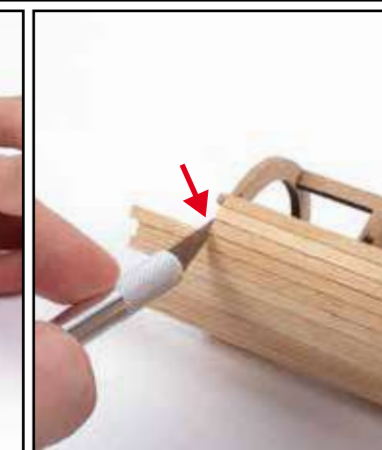
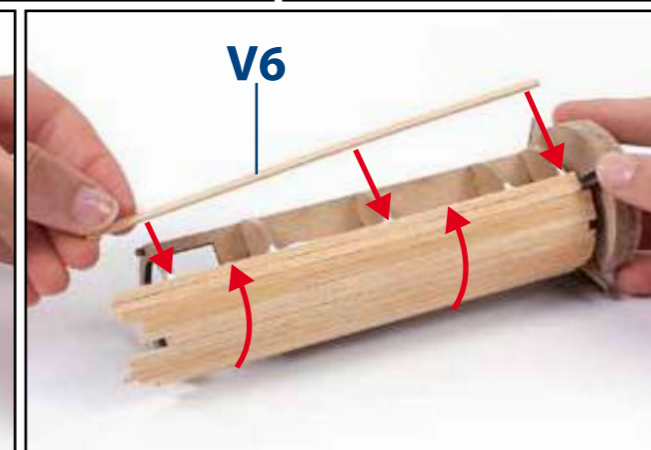
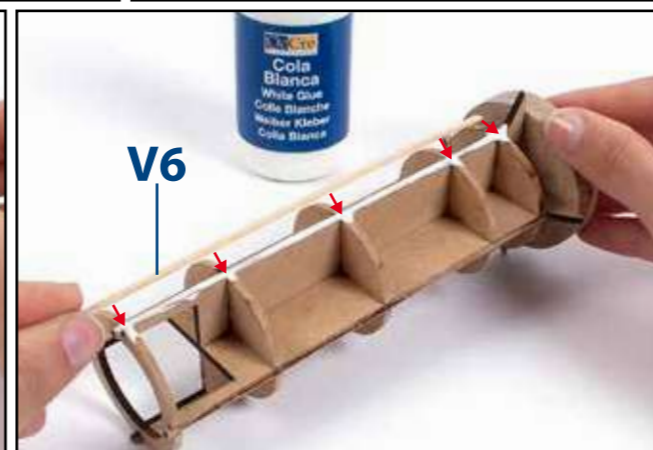
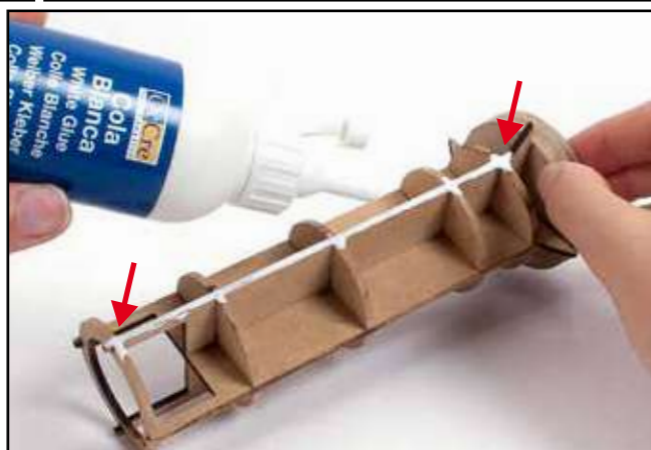
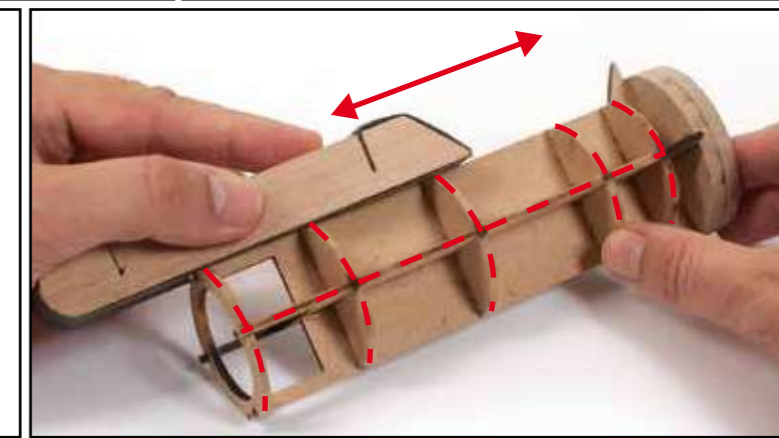
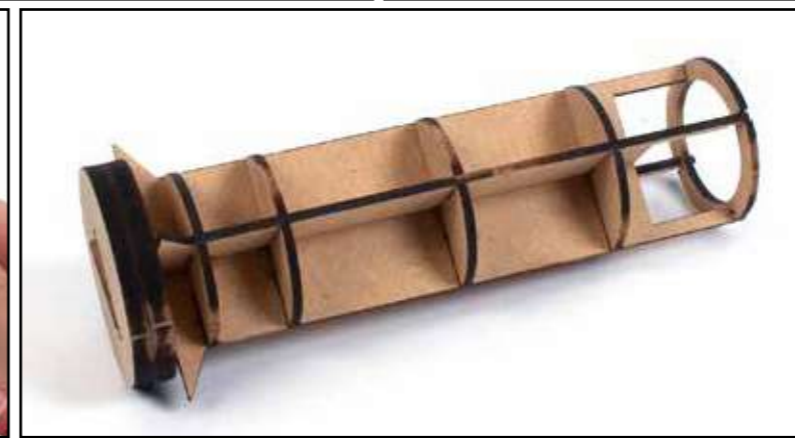
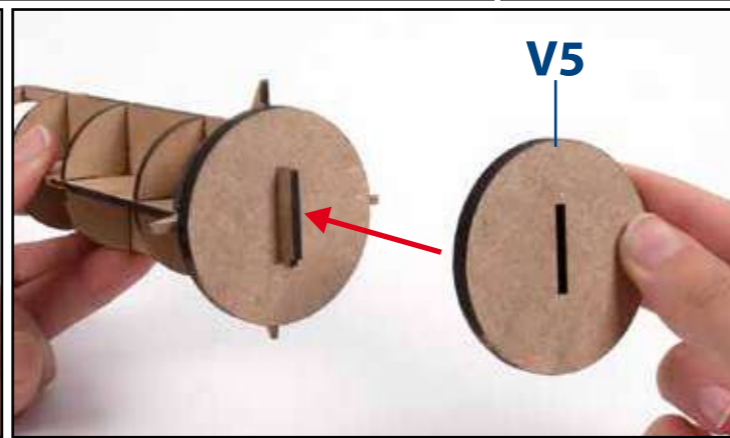
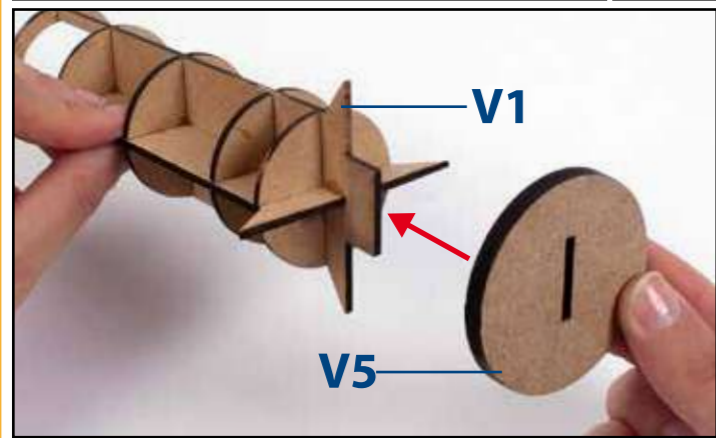
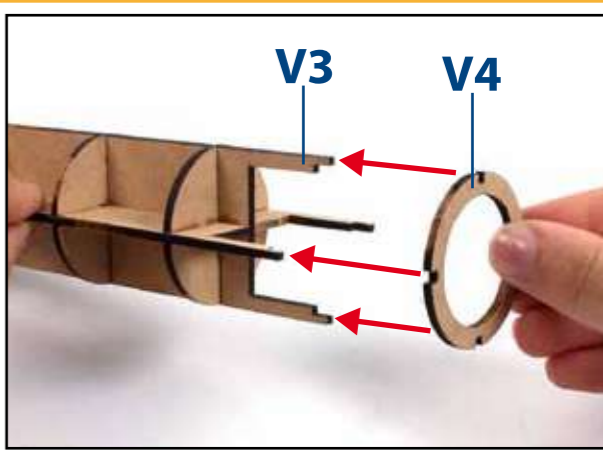
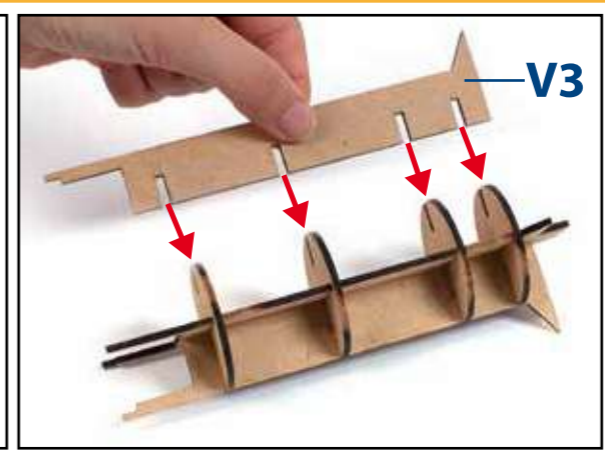
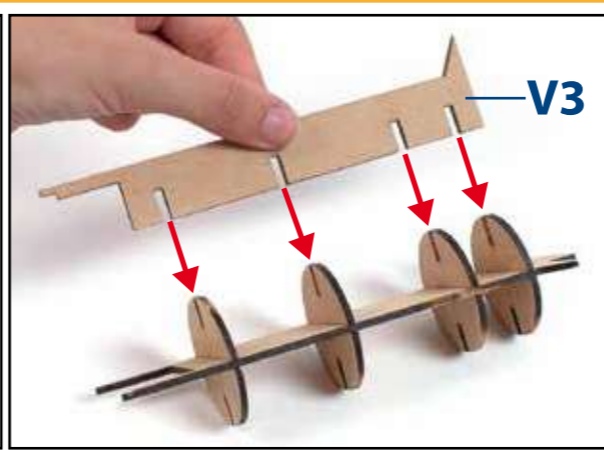
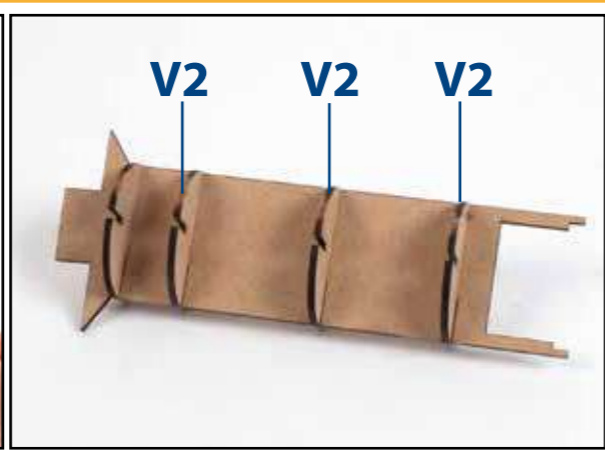
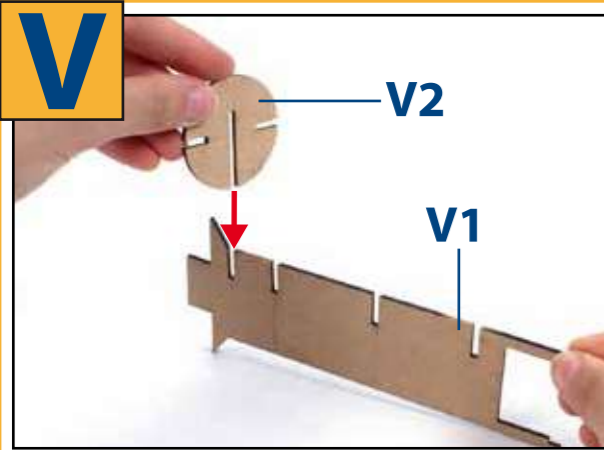

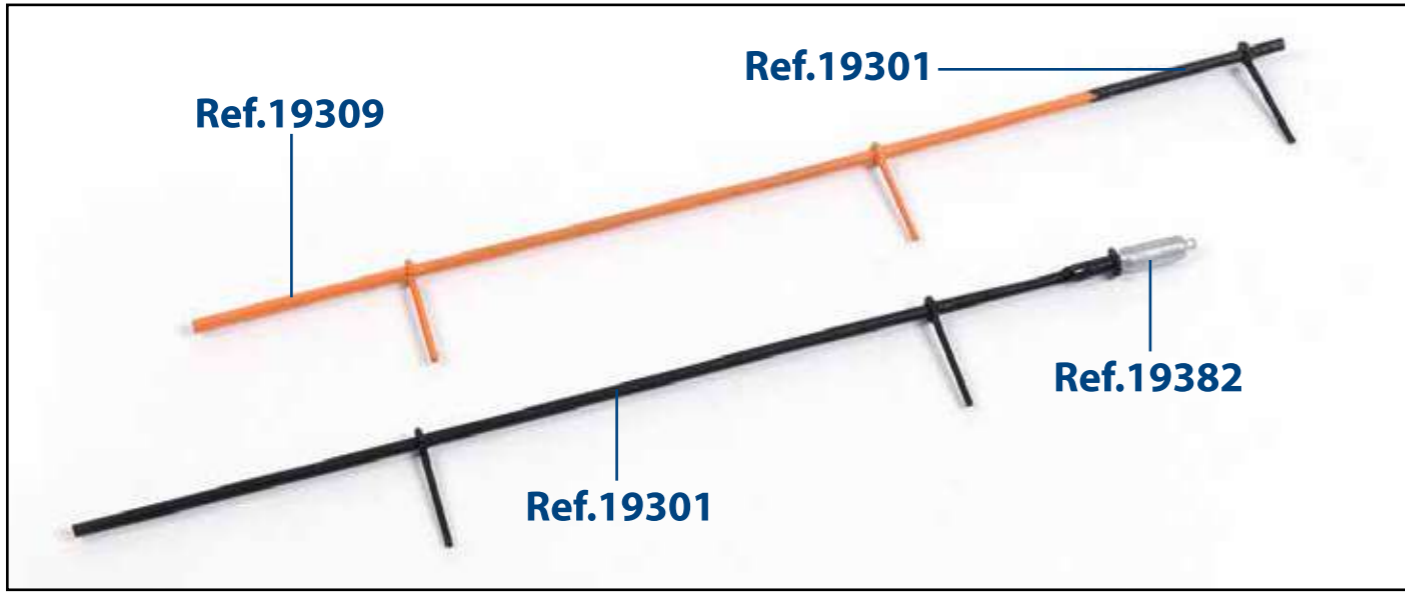
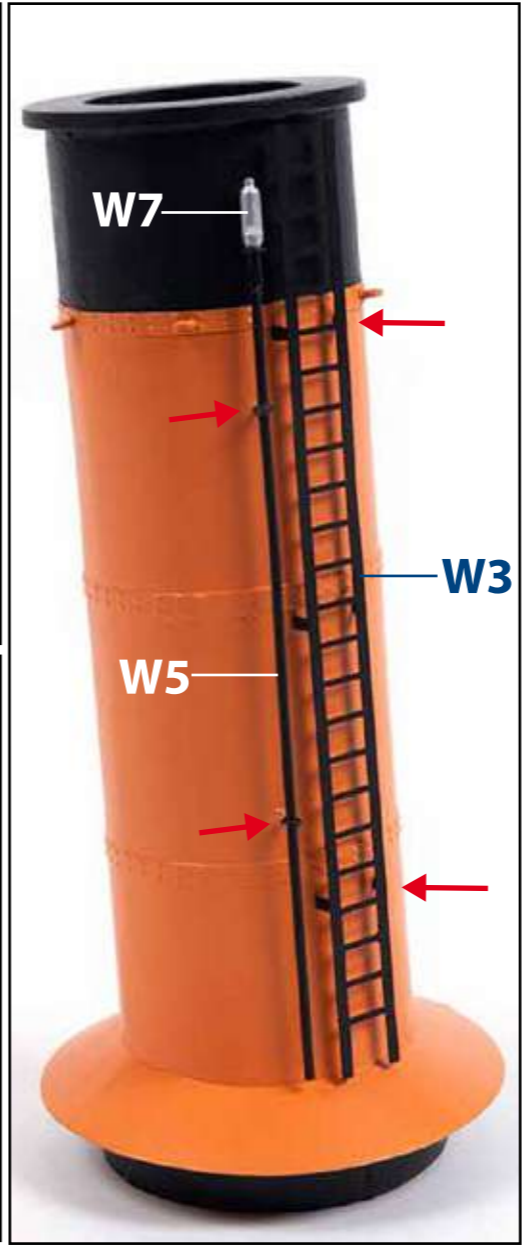
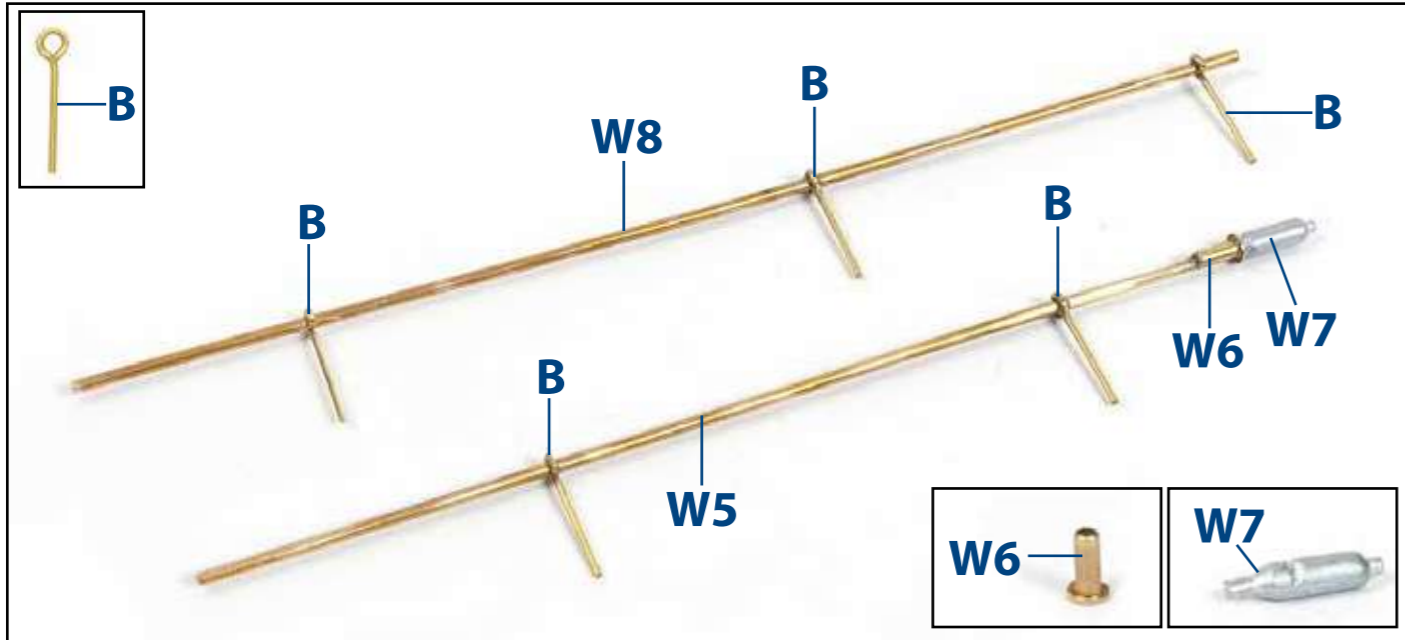
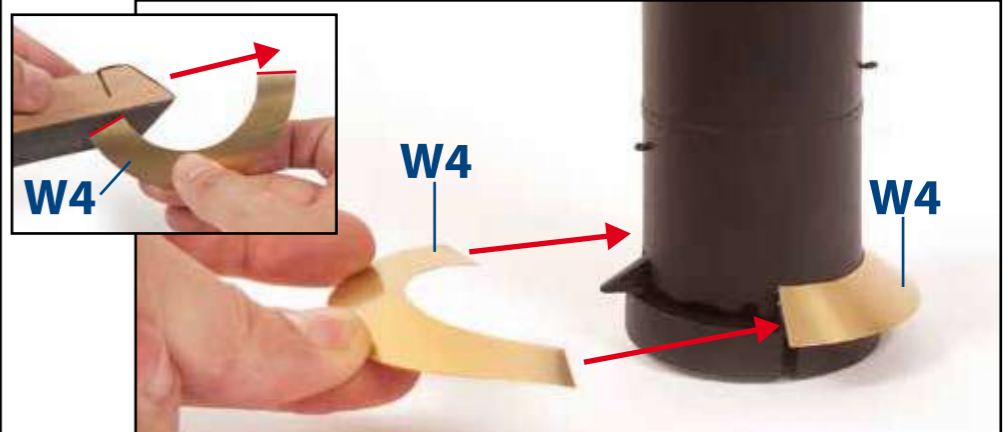
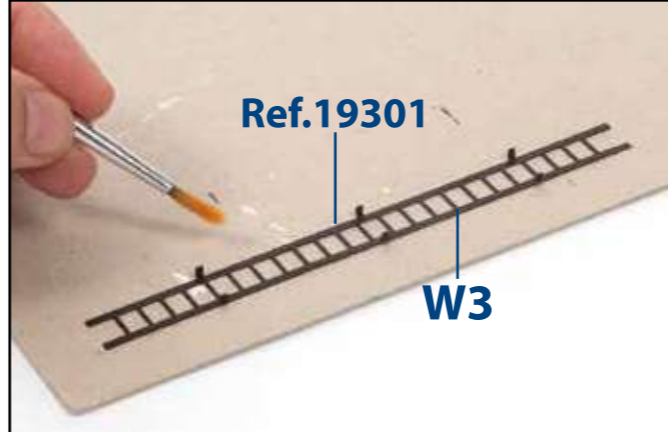
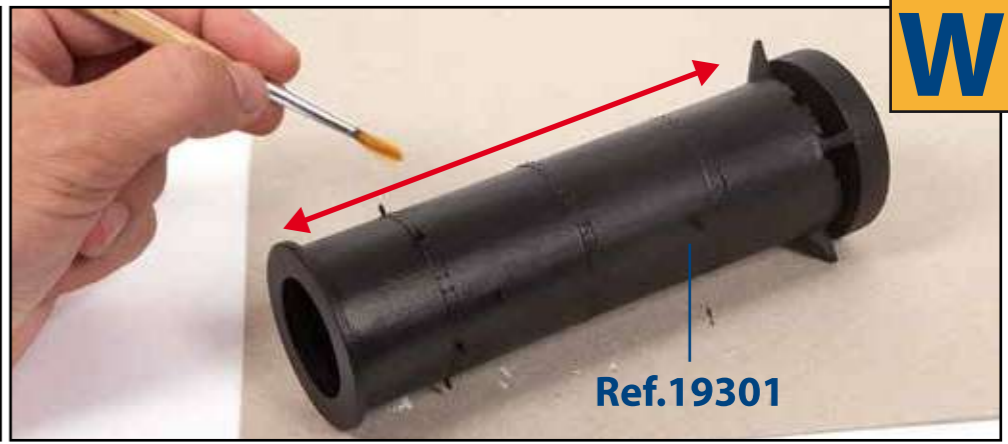
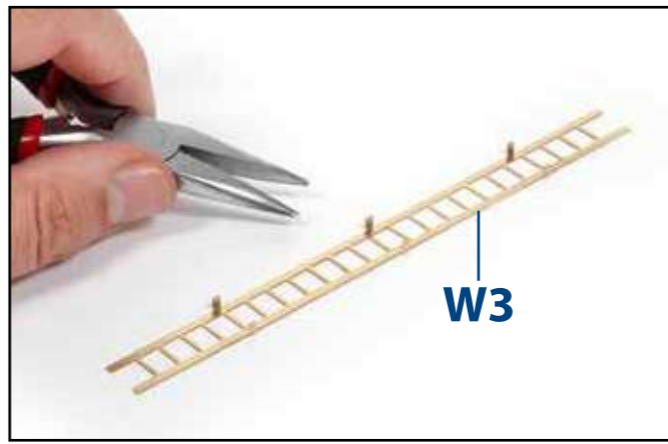
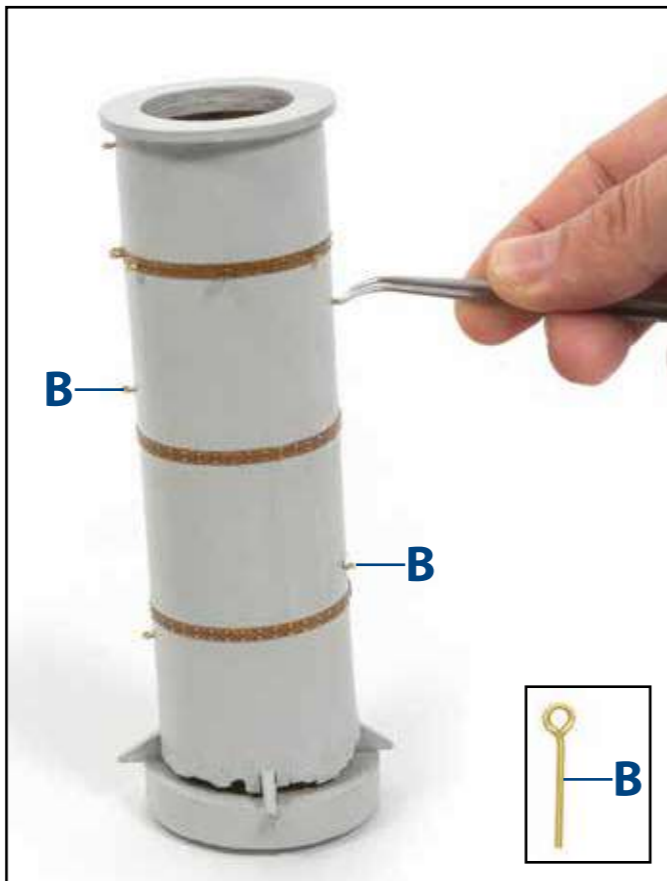
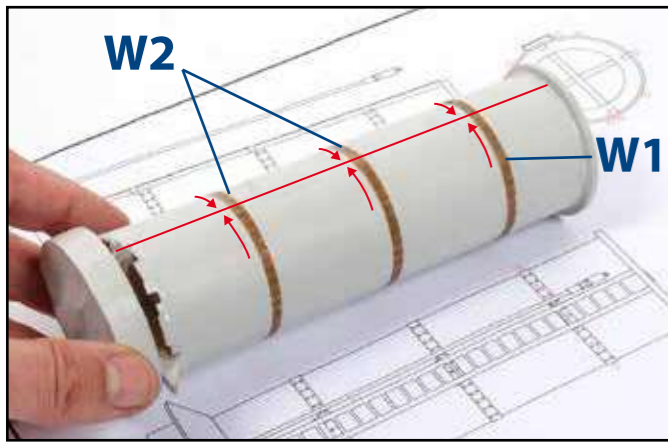

X

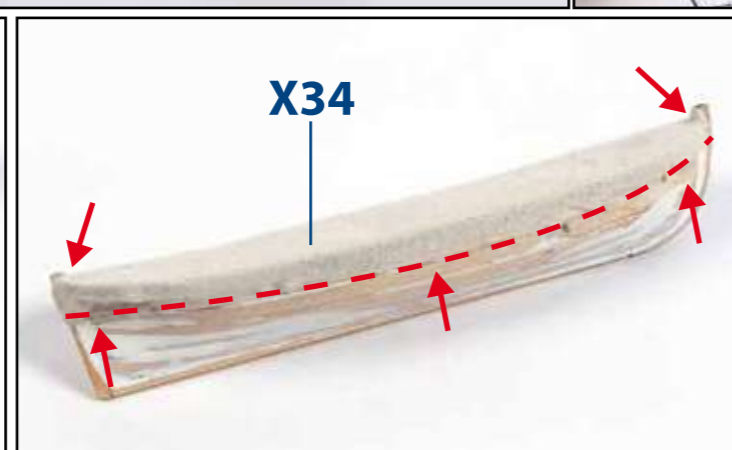
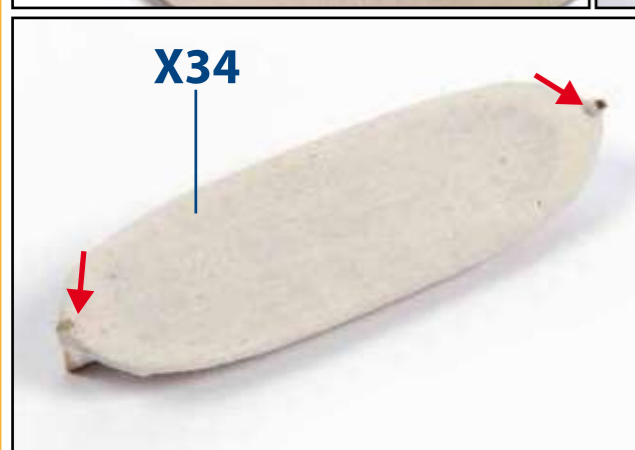
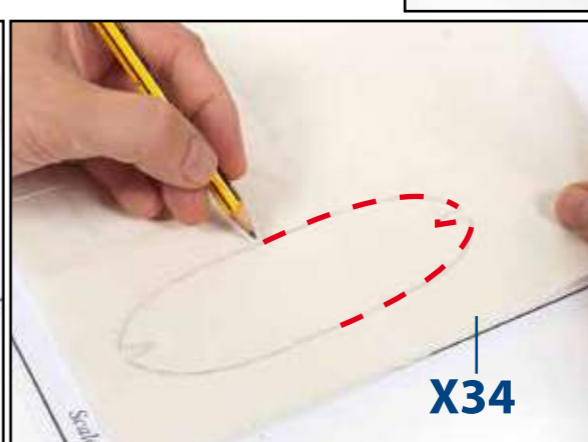
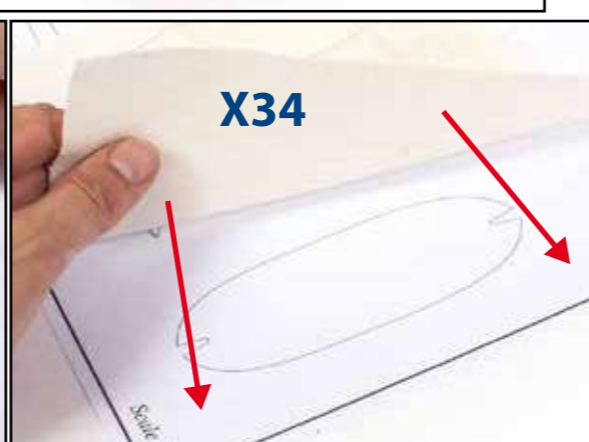
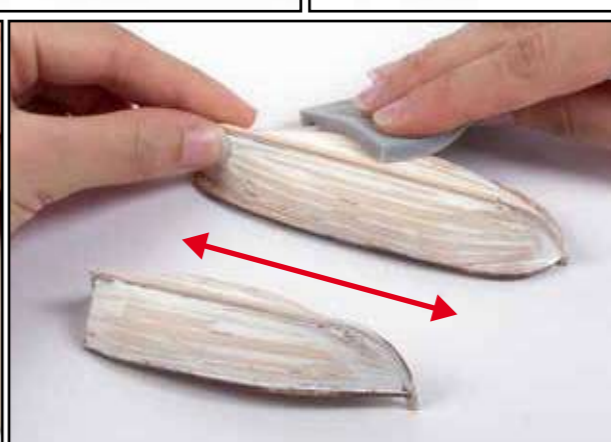
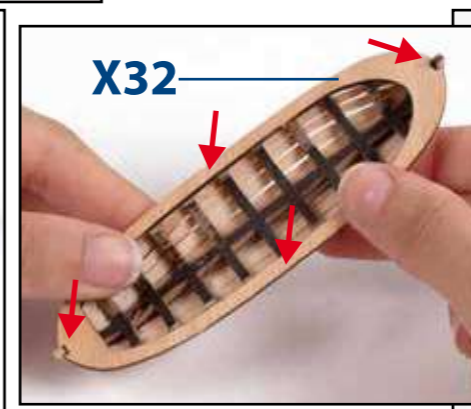
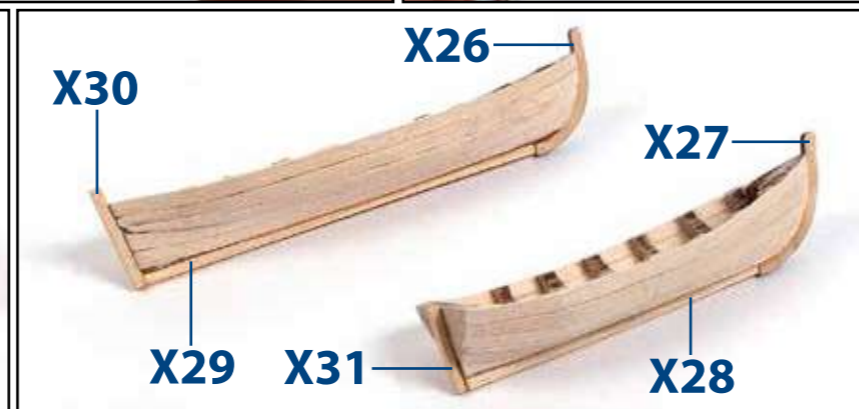
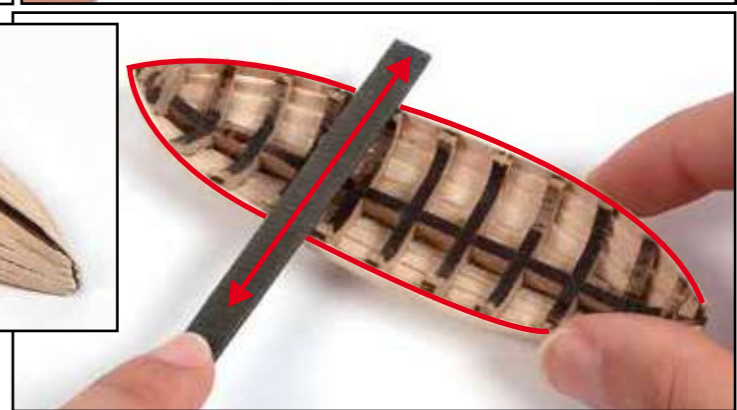
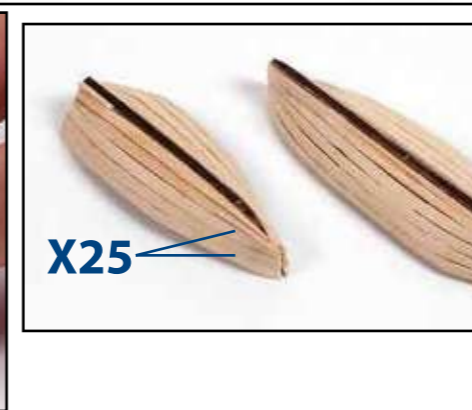
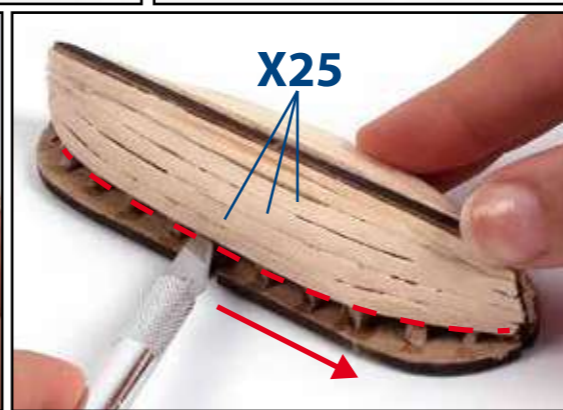
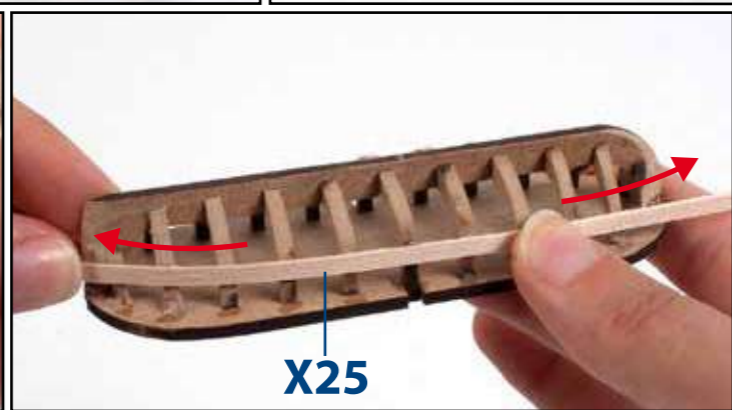
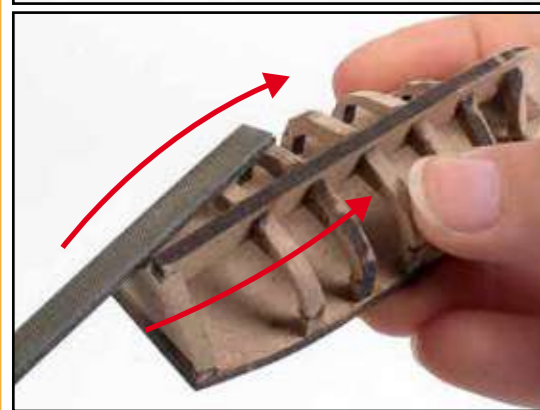
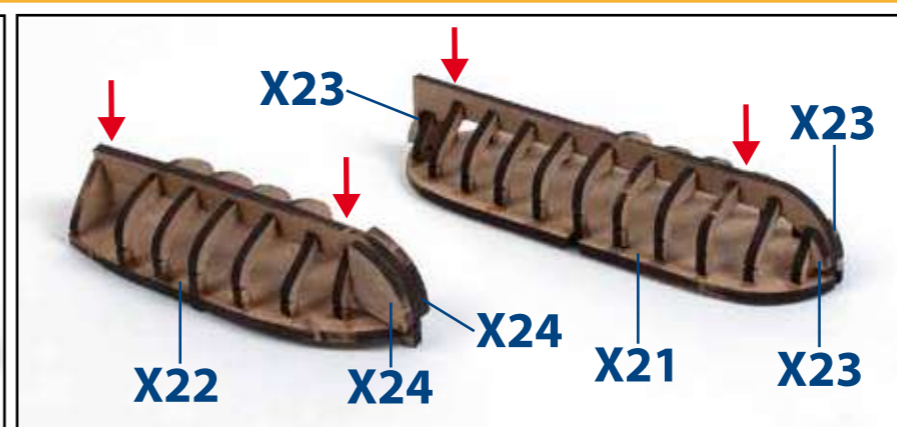
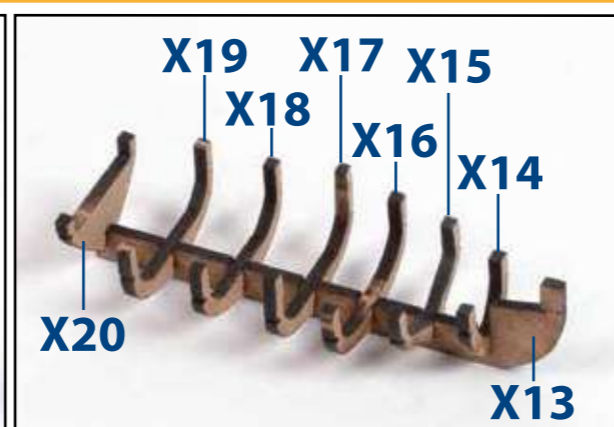
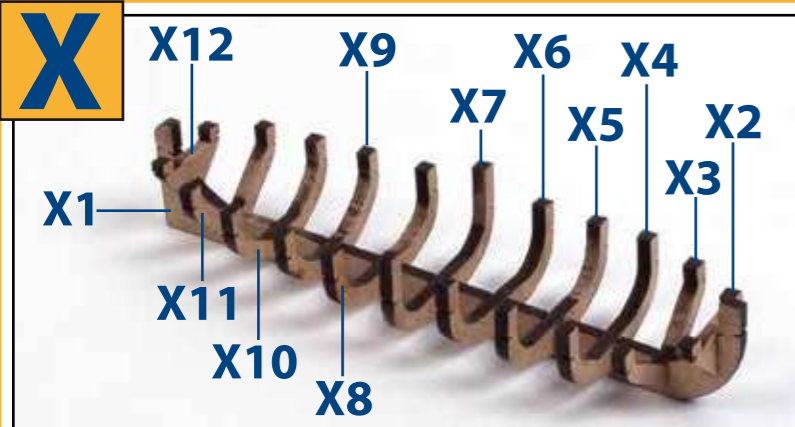

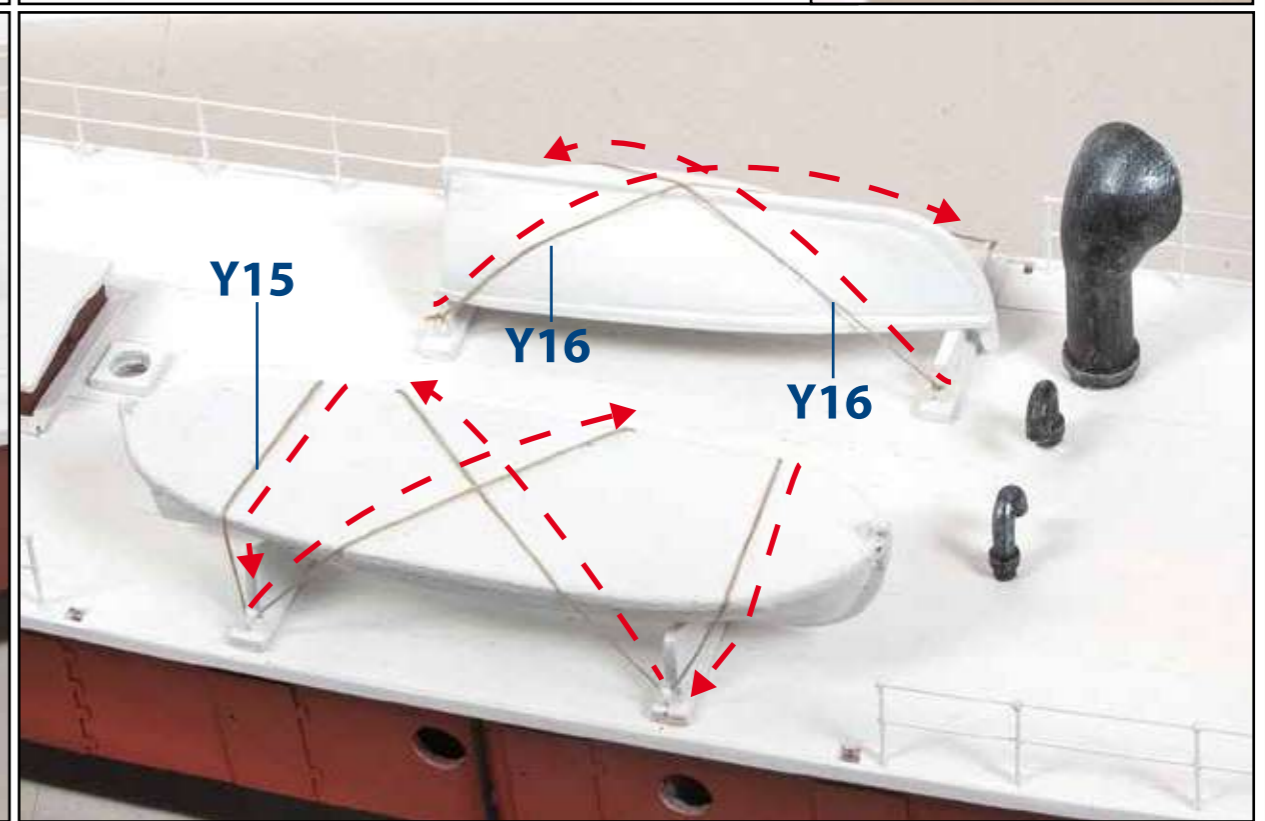
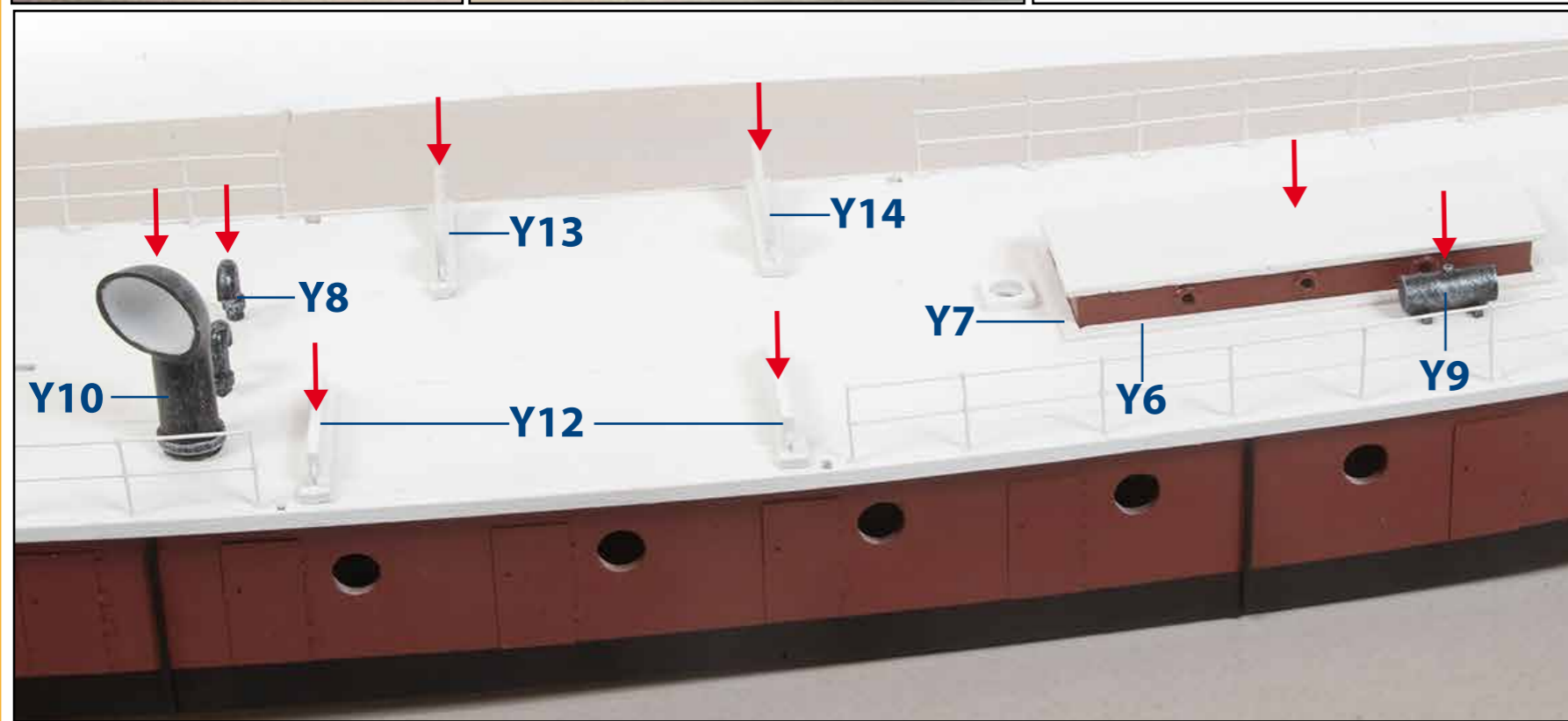
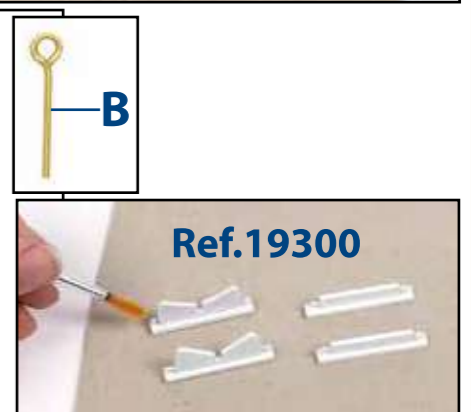
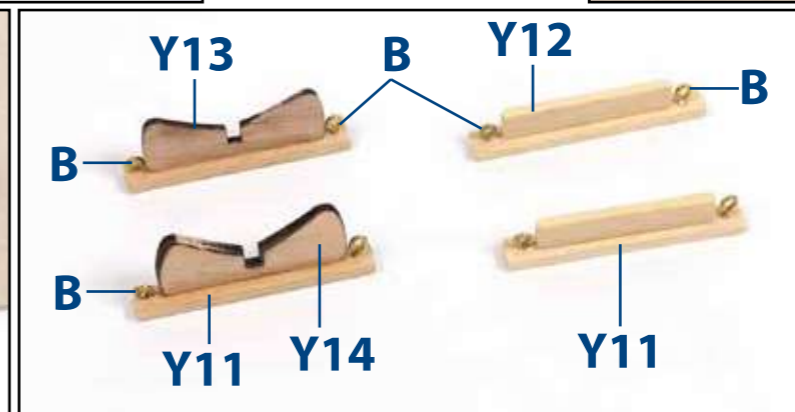
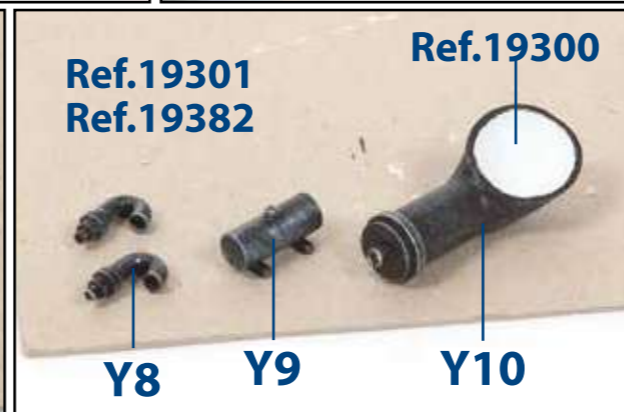
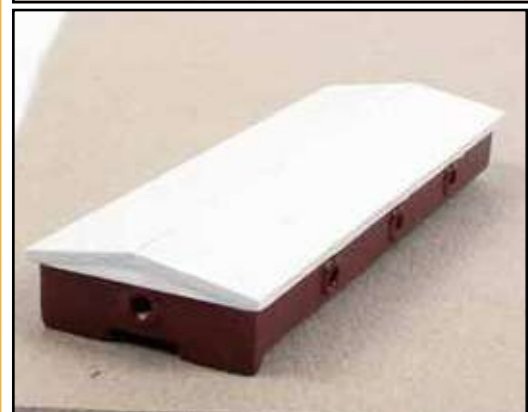
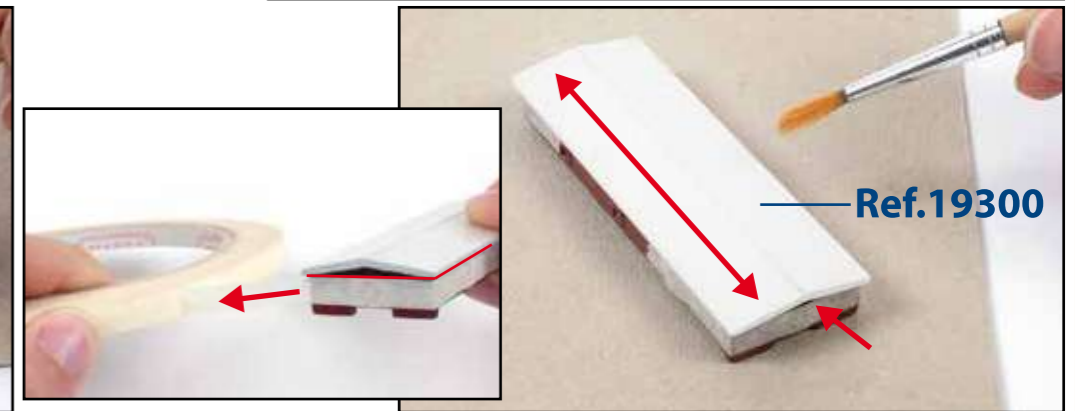
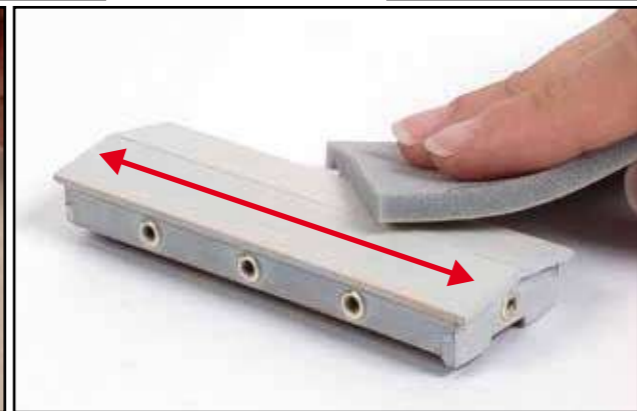
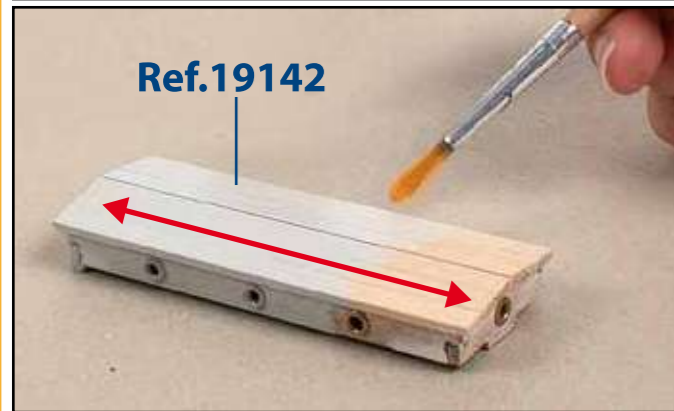
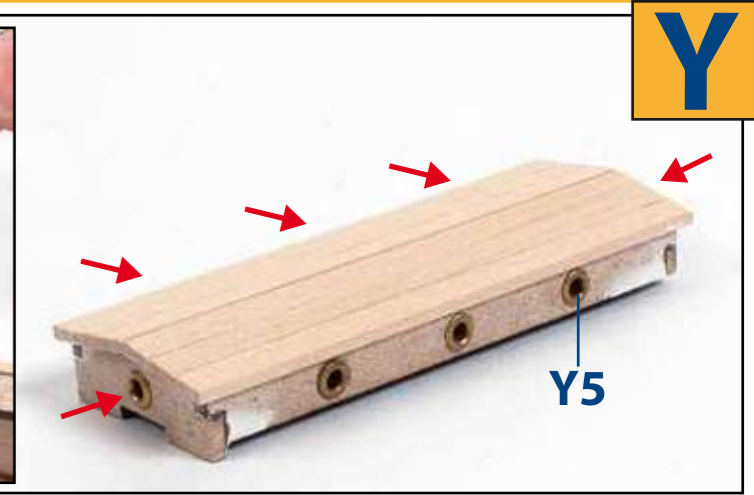
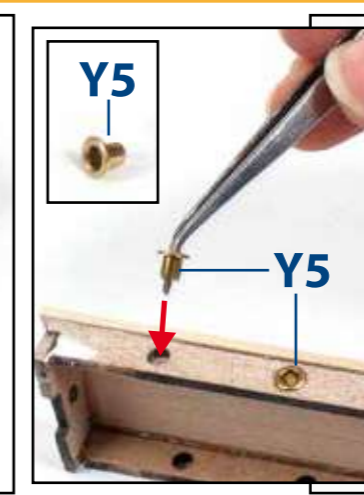
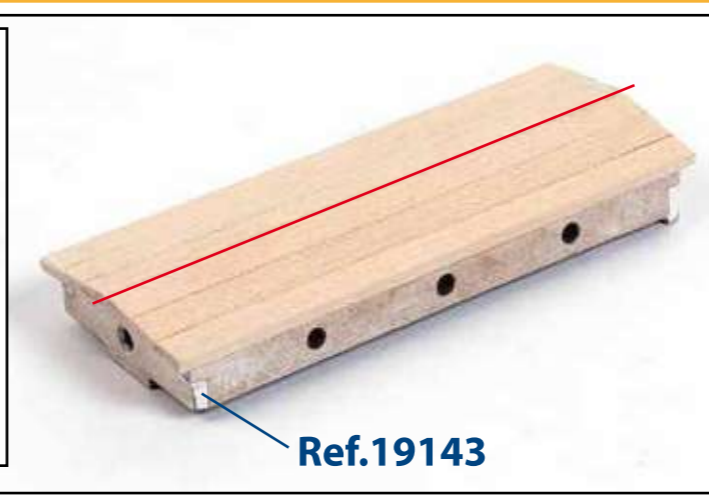
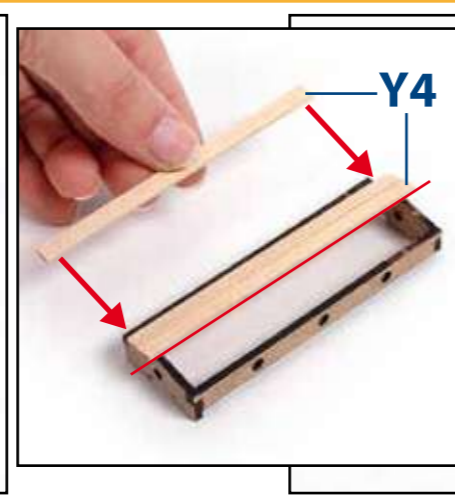
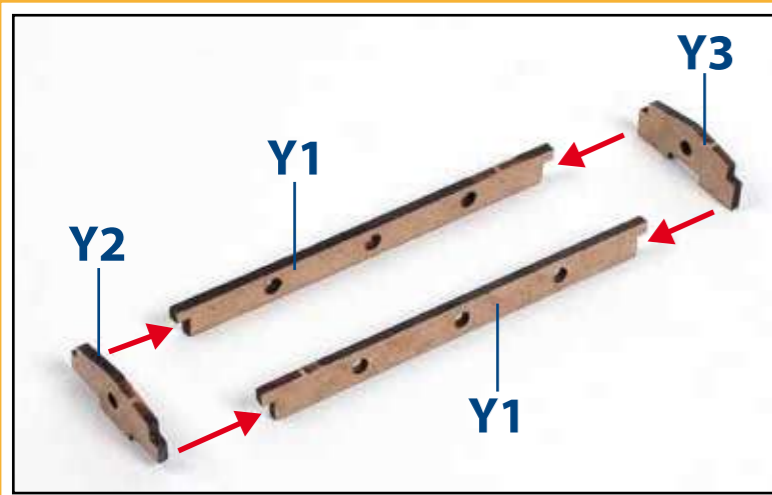

Z

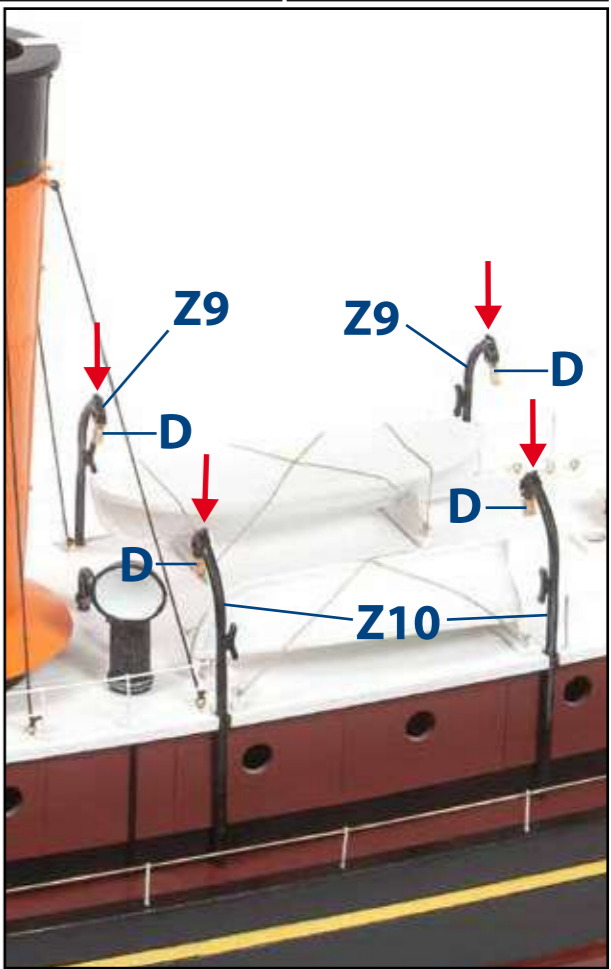
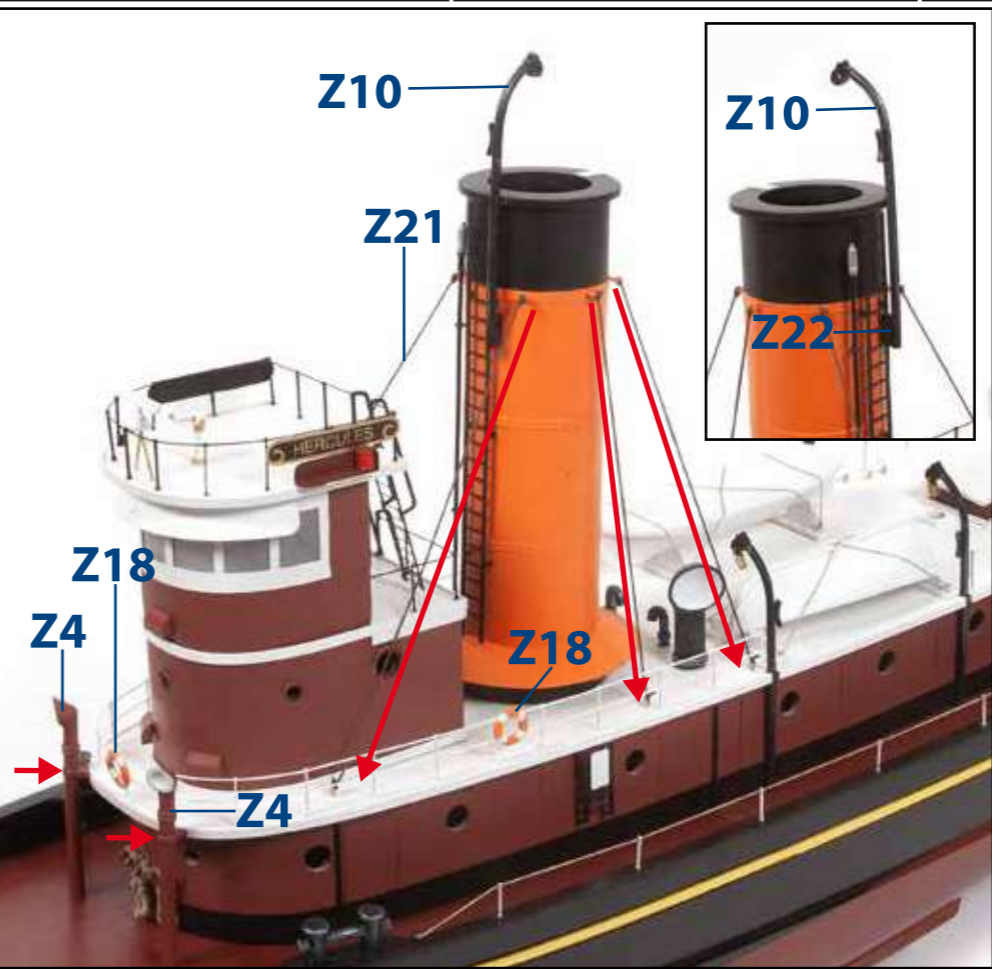
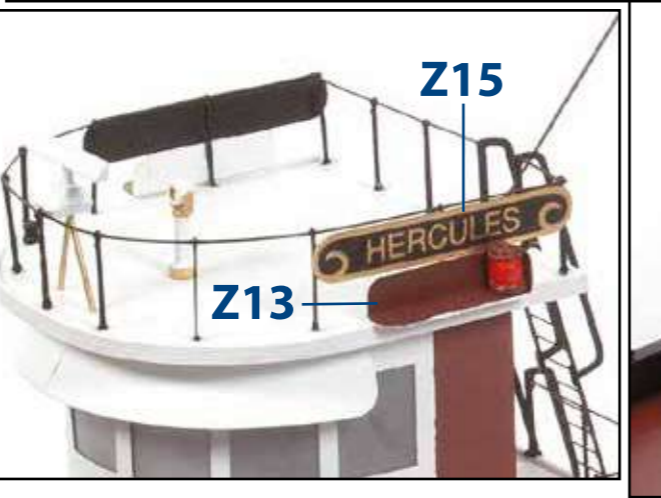
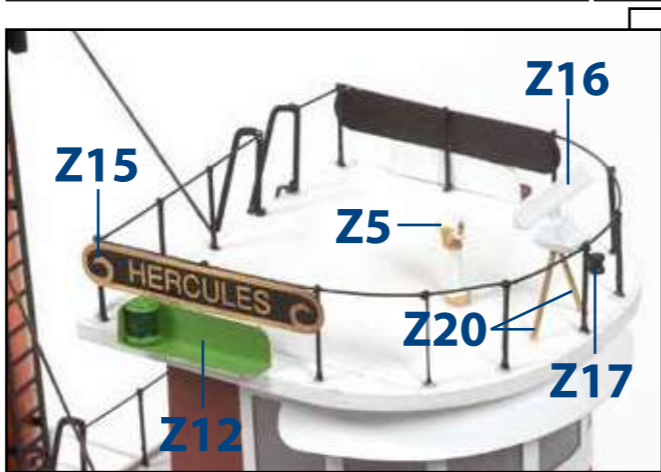
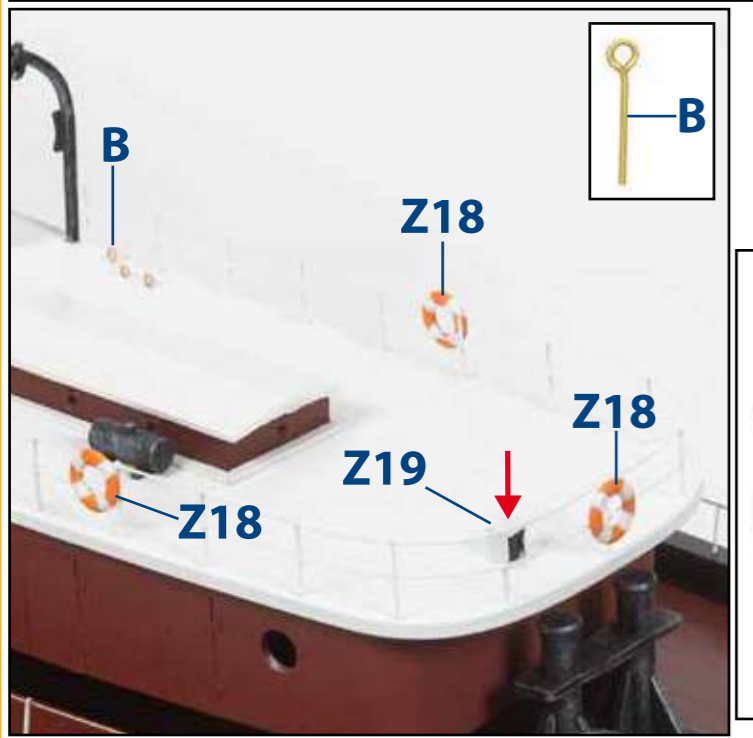
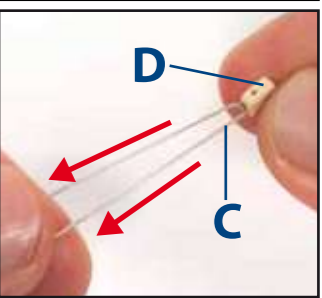
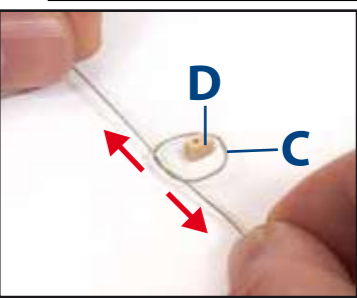
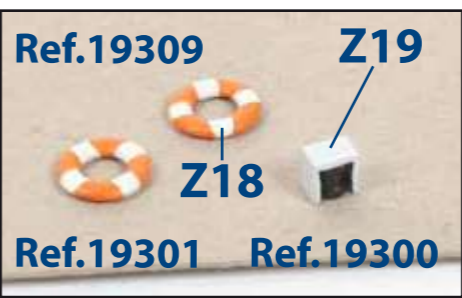
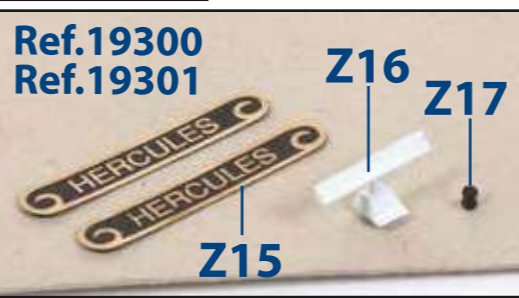
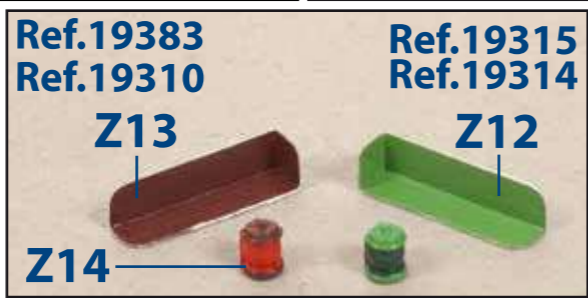
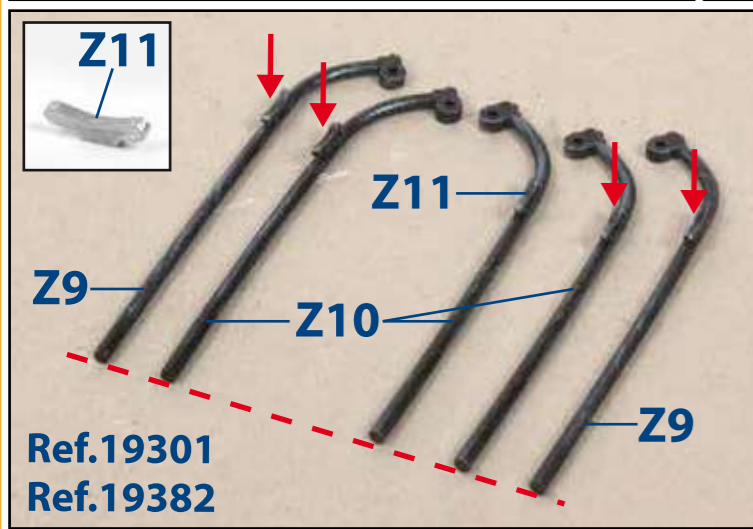
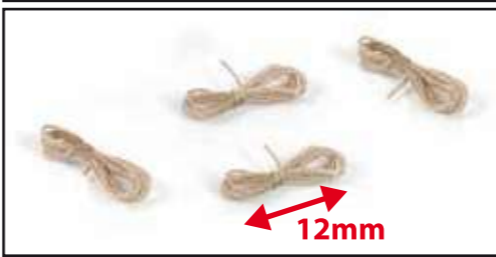
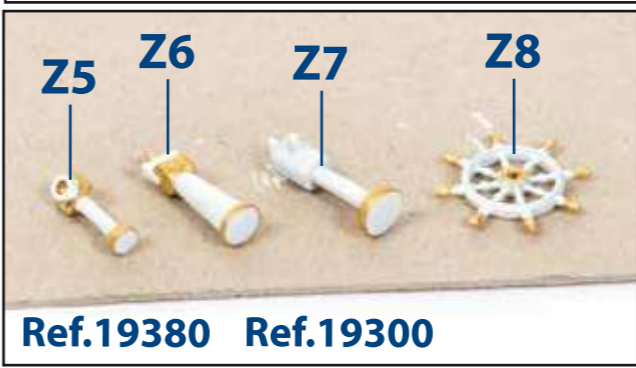
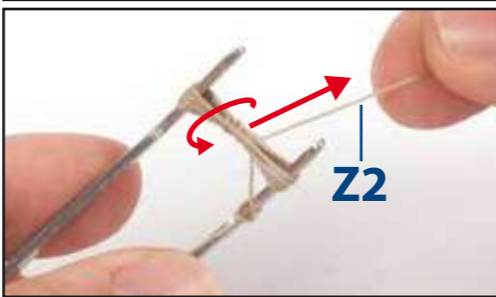
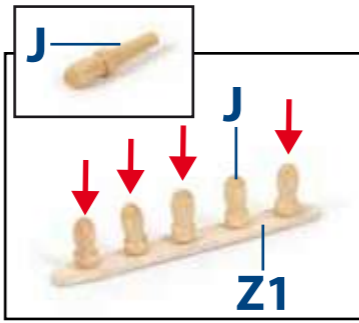
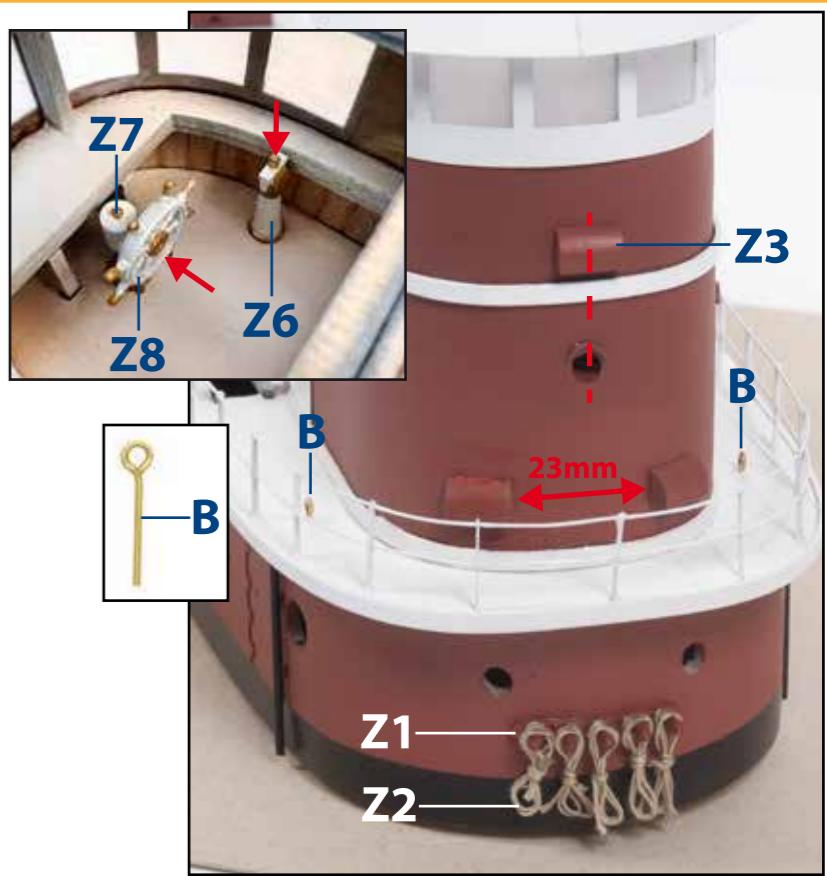
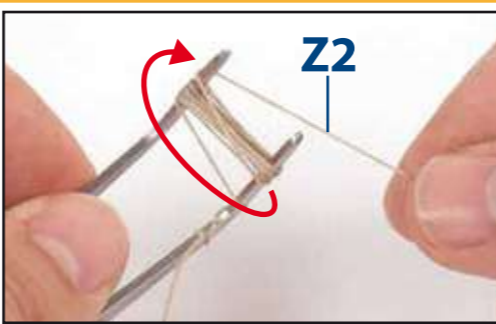
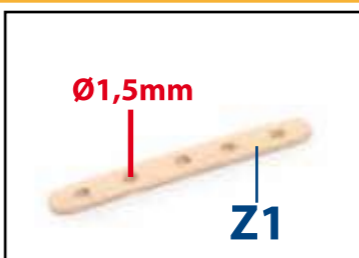
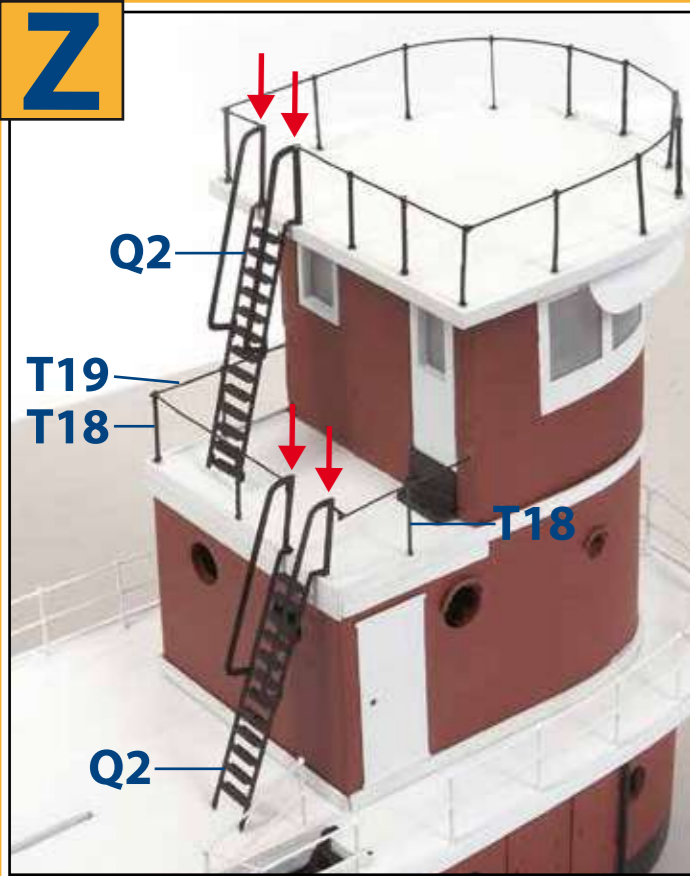

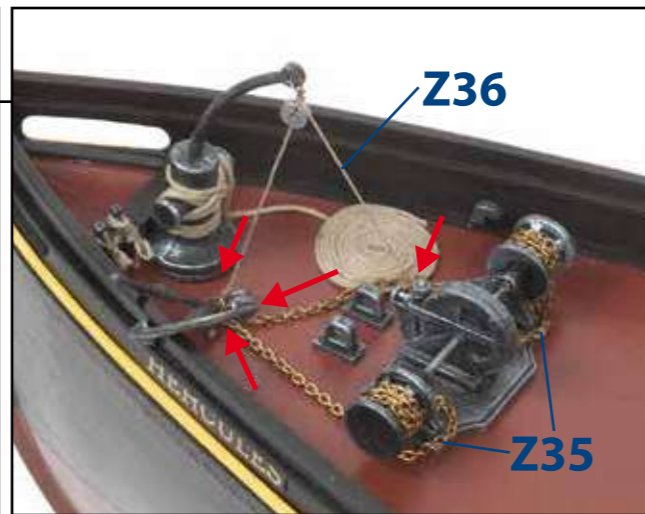
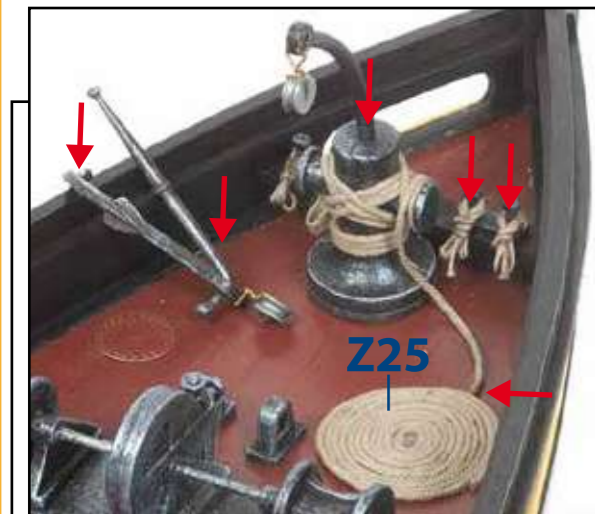
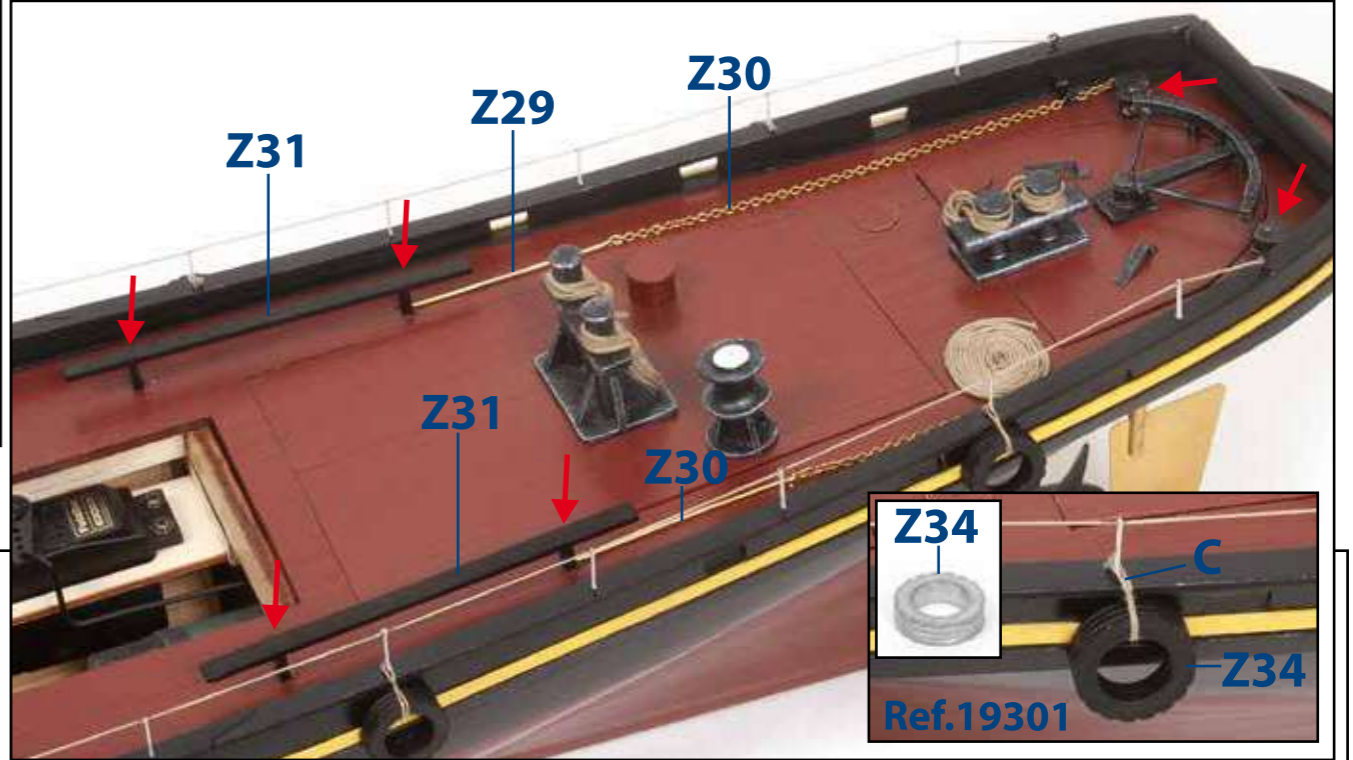
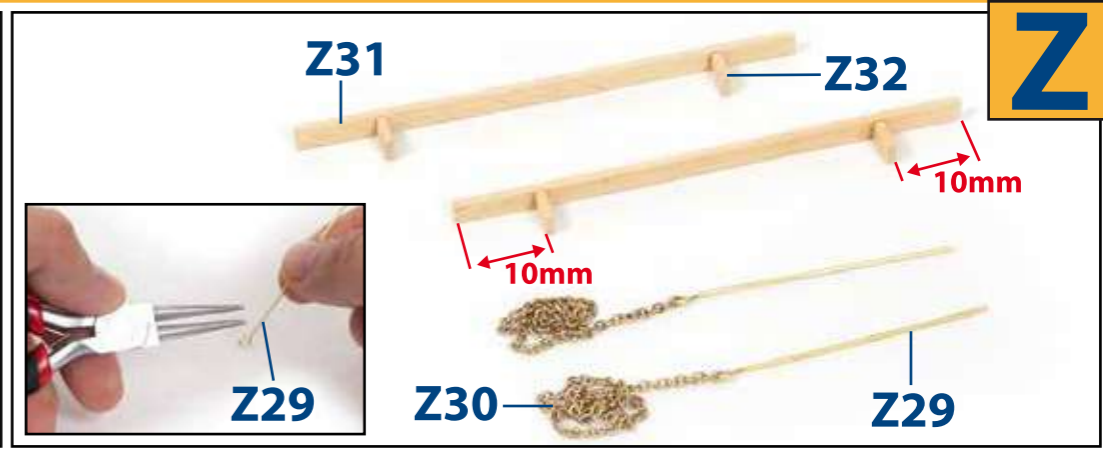
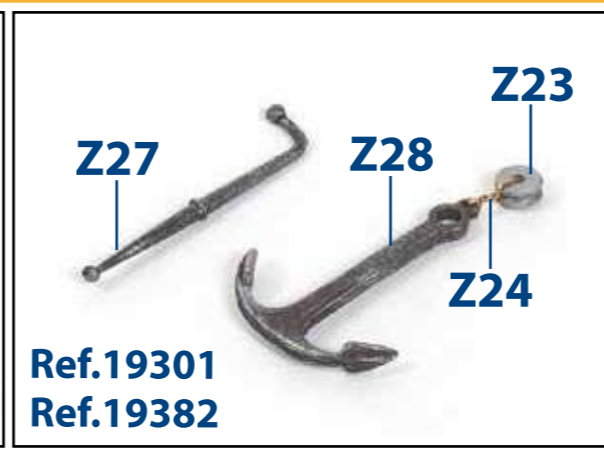
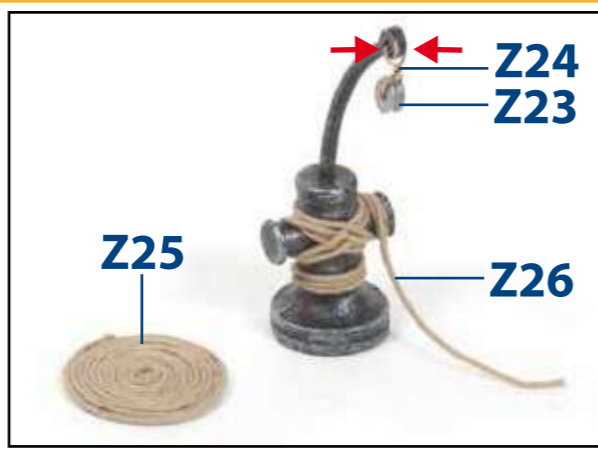
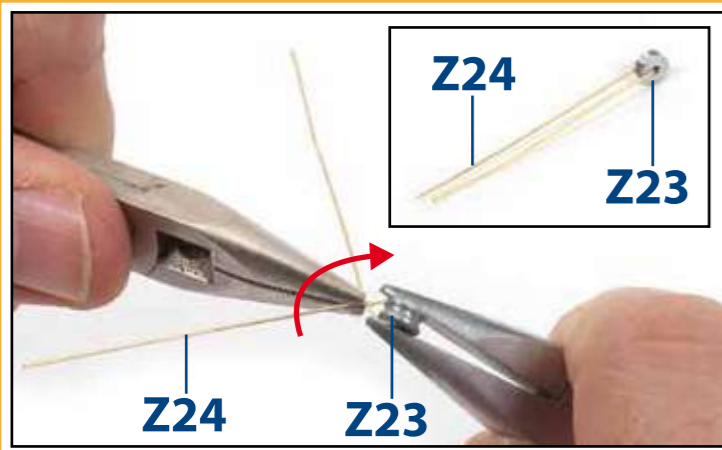

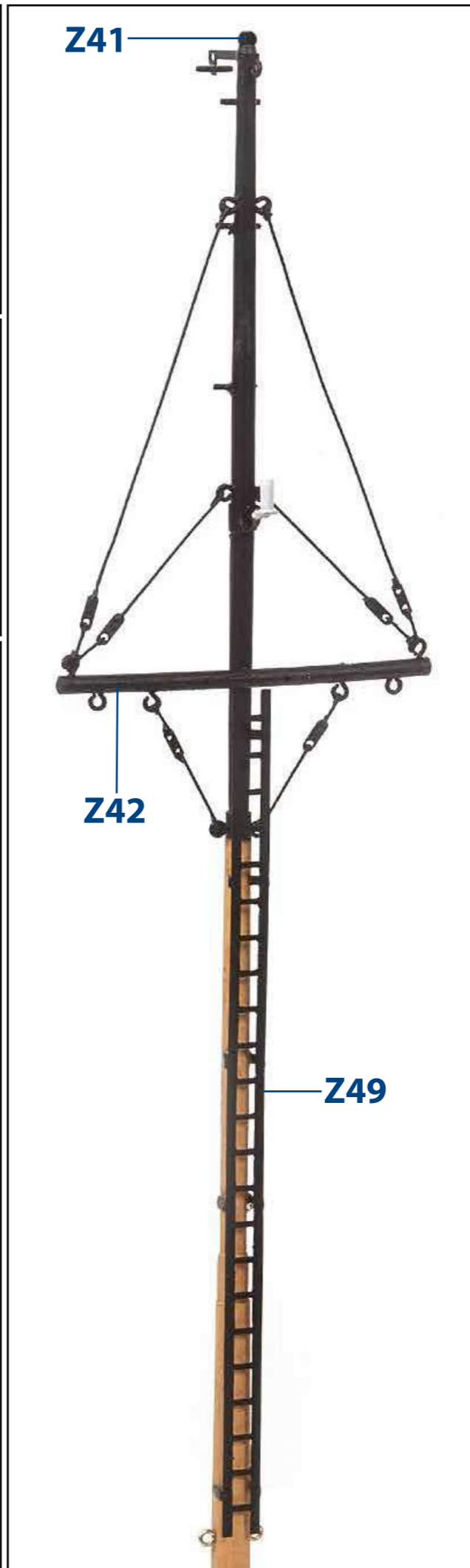
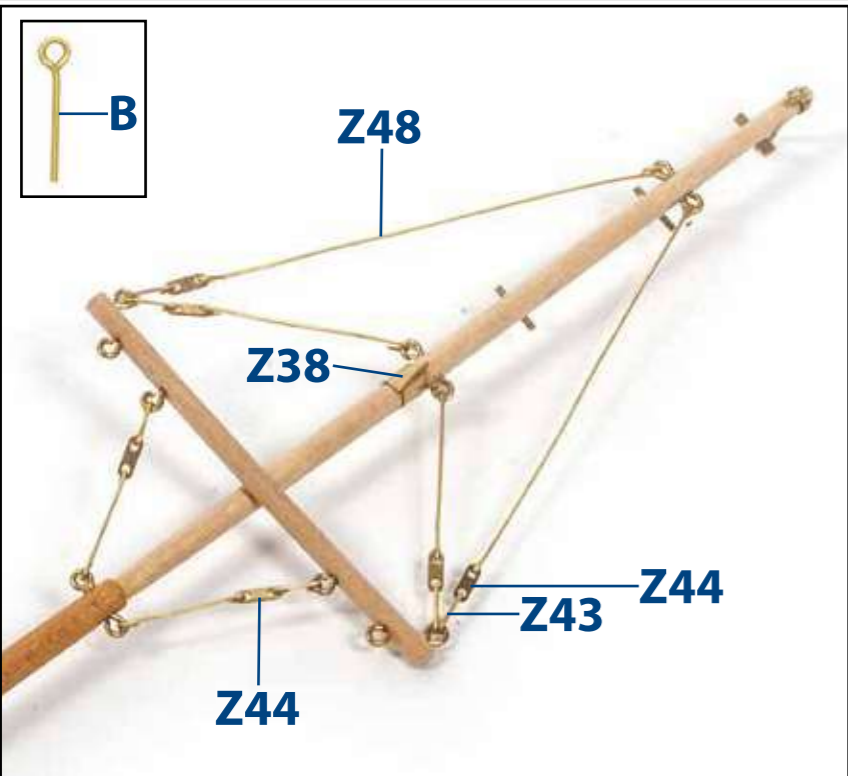
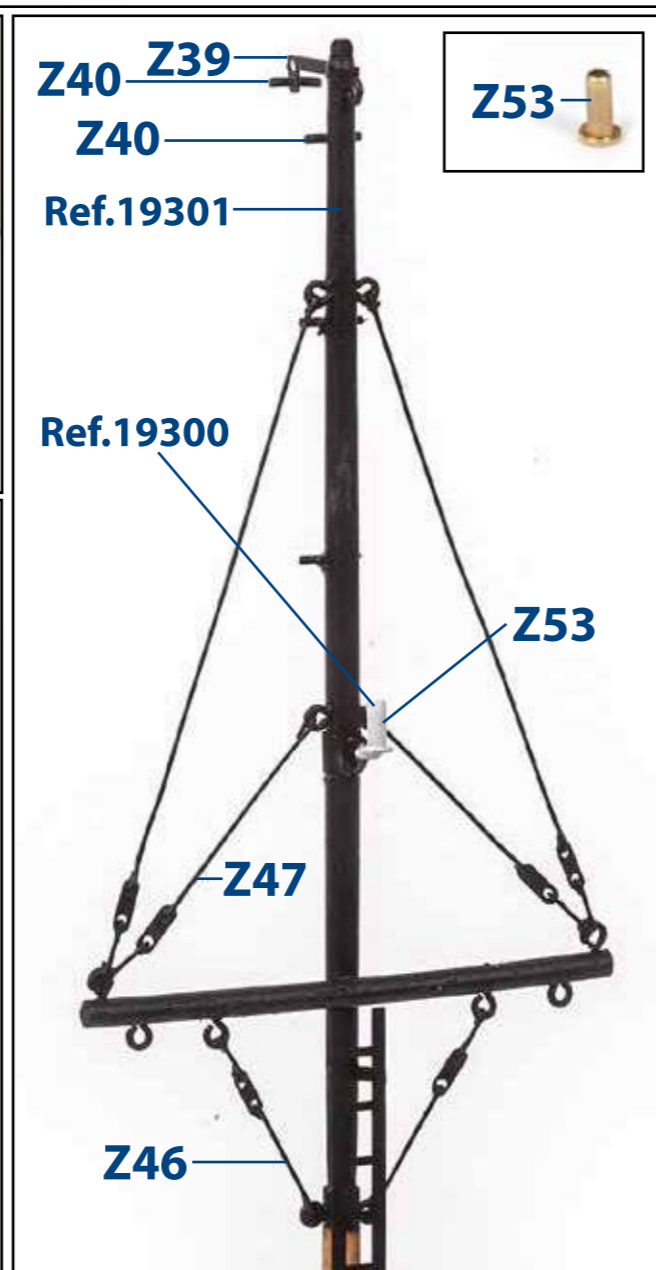
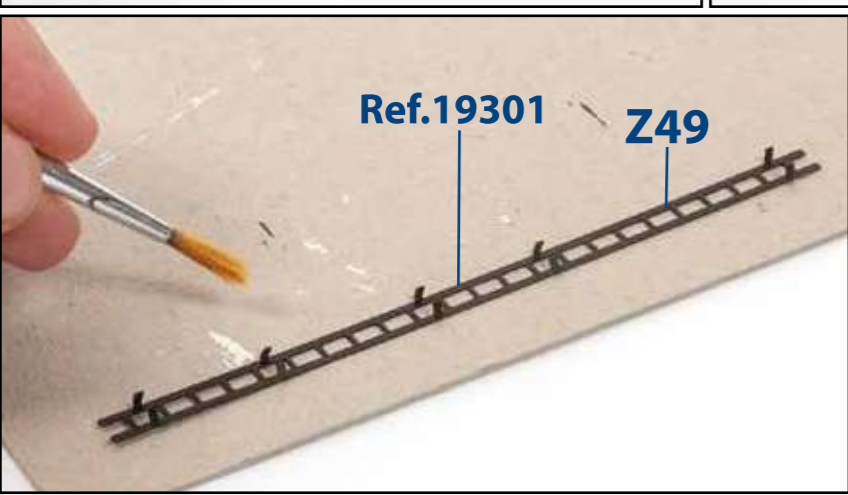
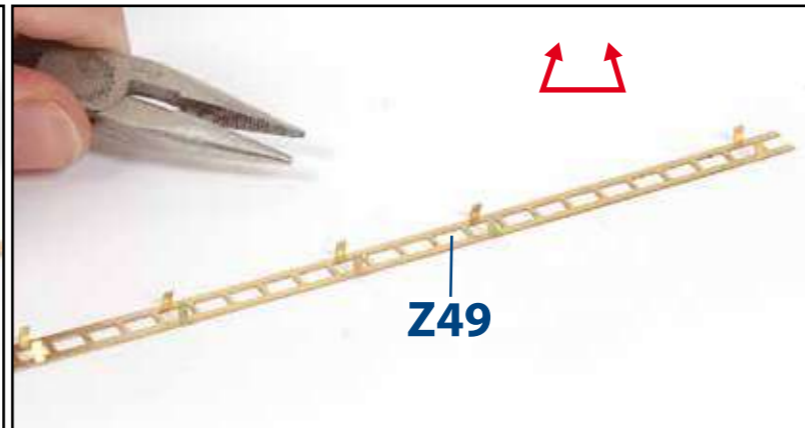
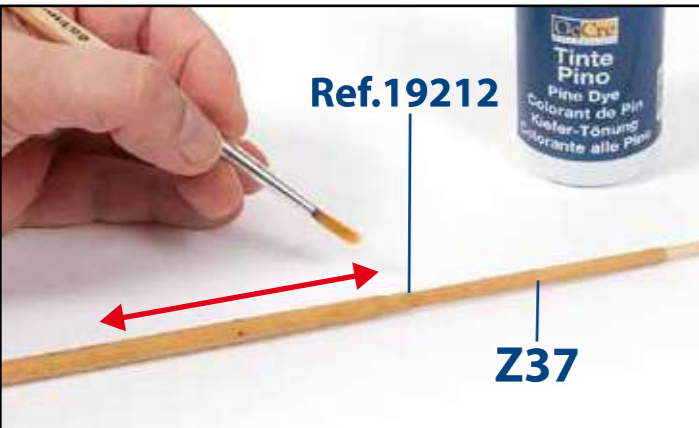
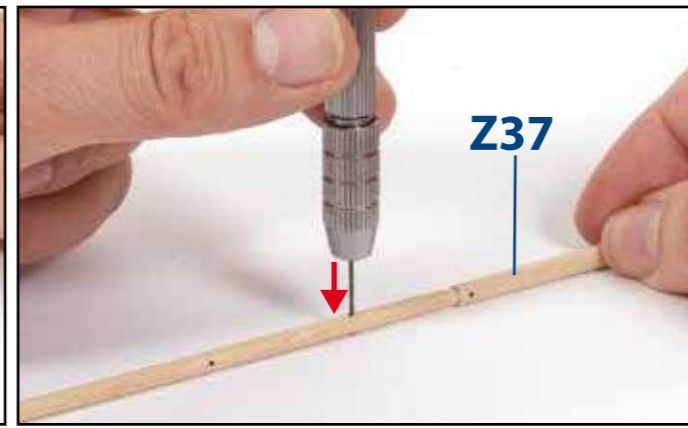
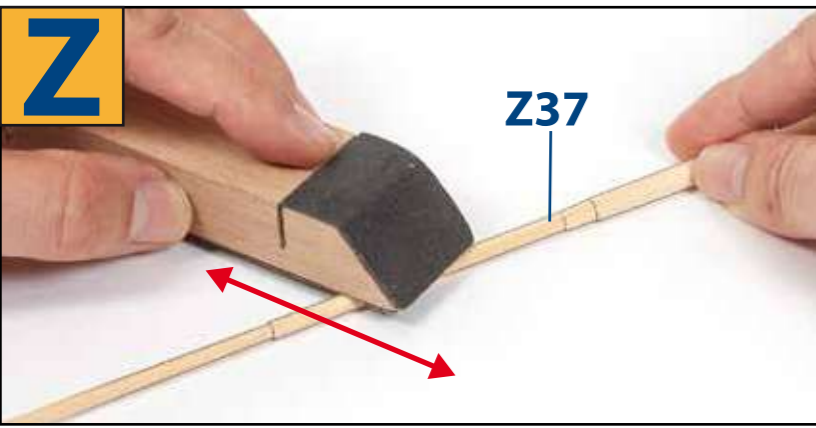

Consultar los planos de mástiles
 Consult the masts drawings
 Consulte os desenhos dos mastros
 Consulter les dessins des mâts
 Konsultieren Sie die Mastenzeichnungen
 Обратитесь к рисункам мачты
 Consultare i disegni degli alberi

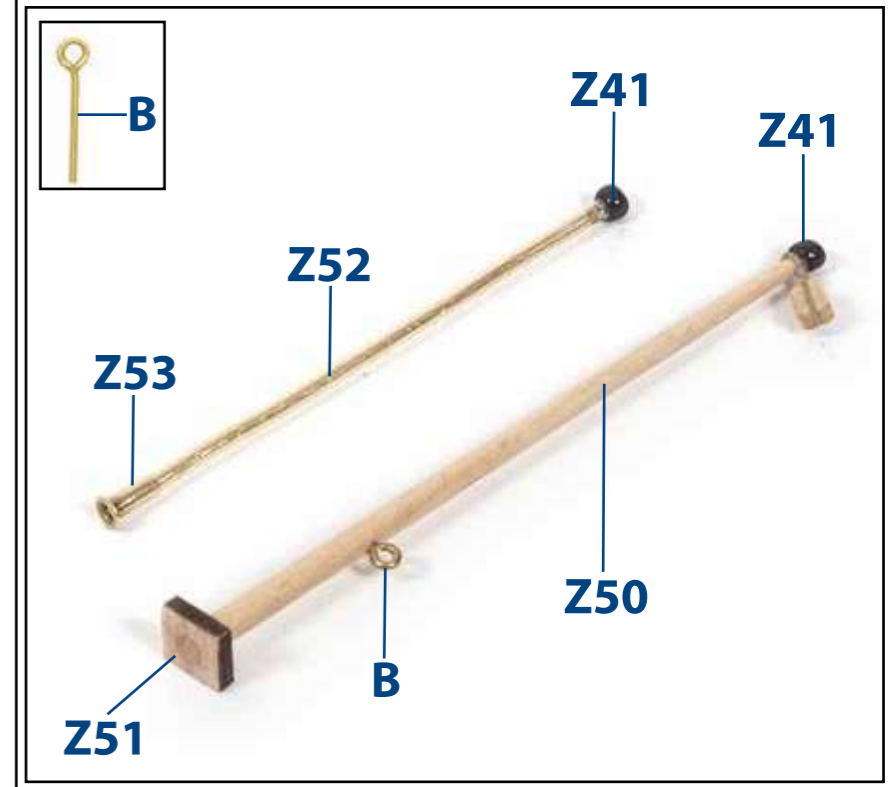
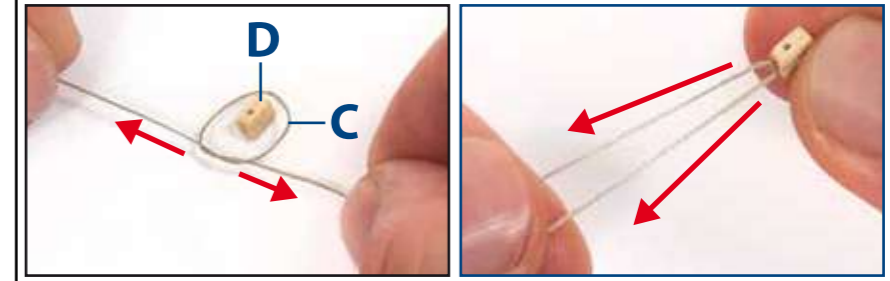

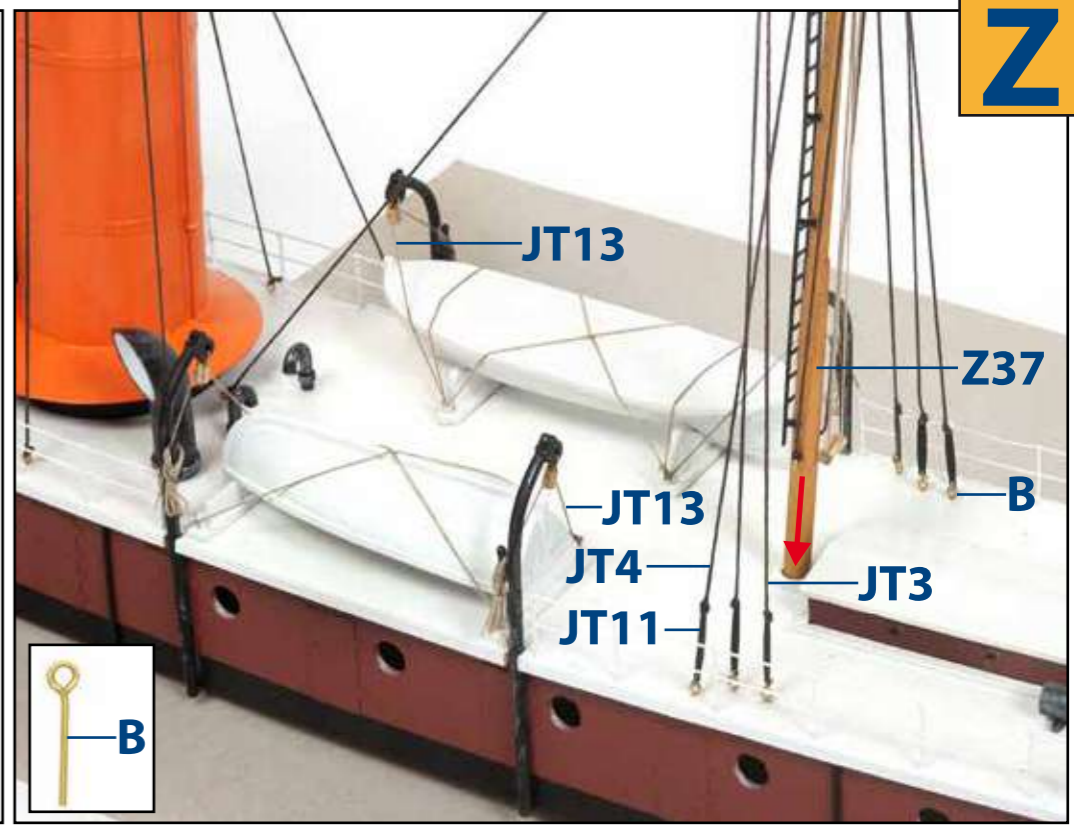
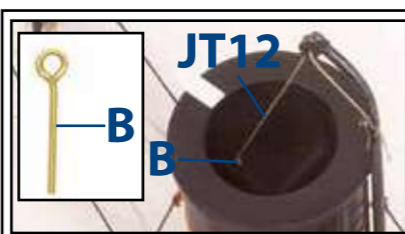
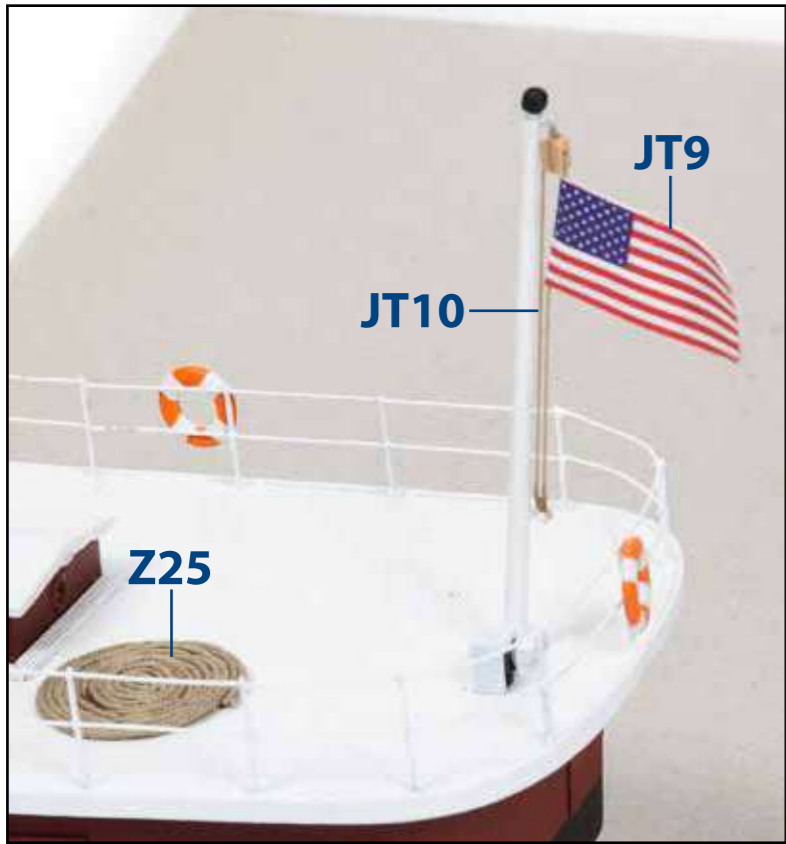
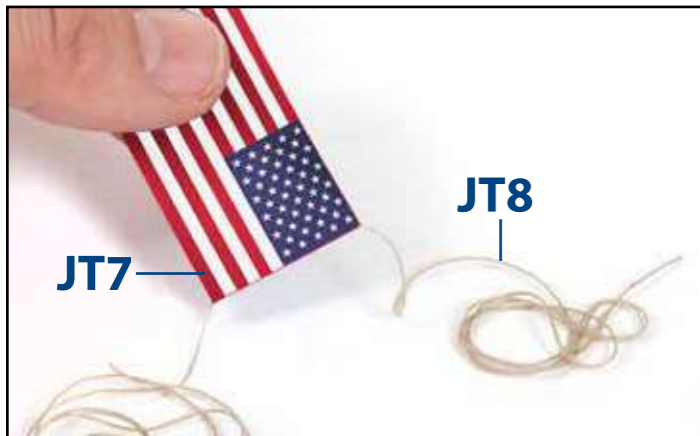
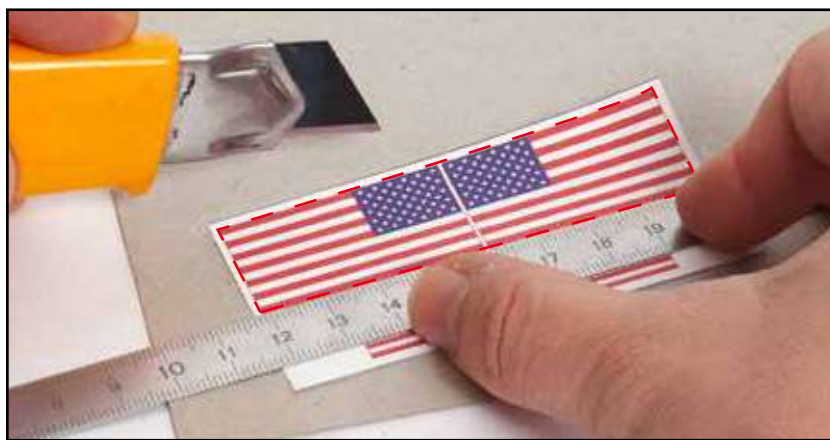

Z

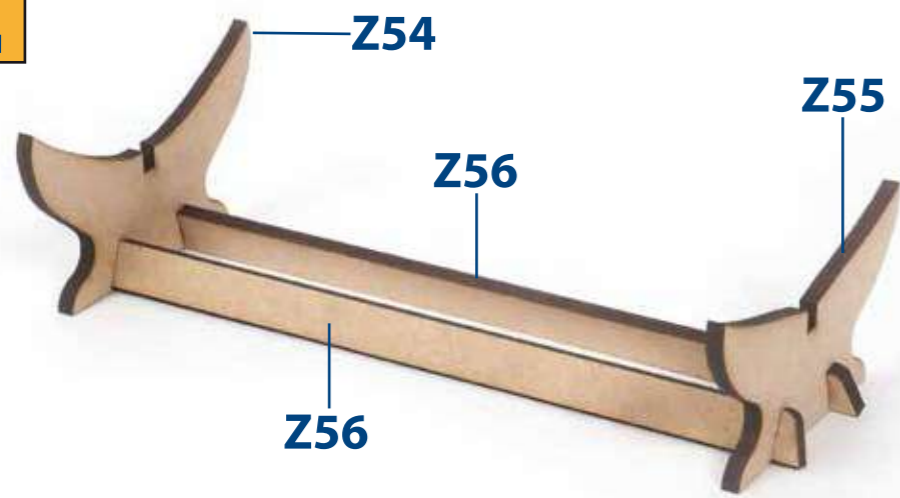

IP

Hercules

Ref.61002

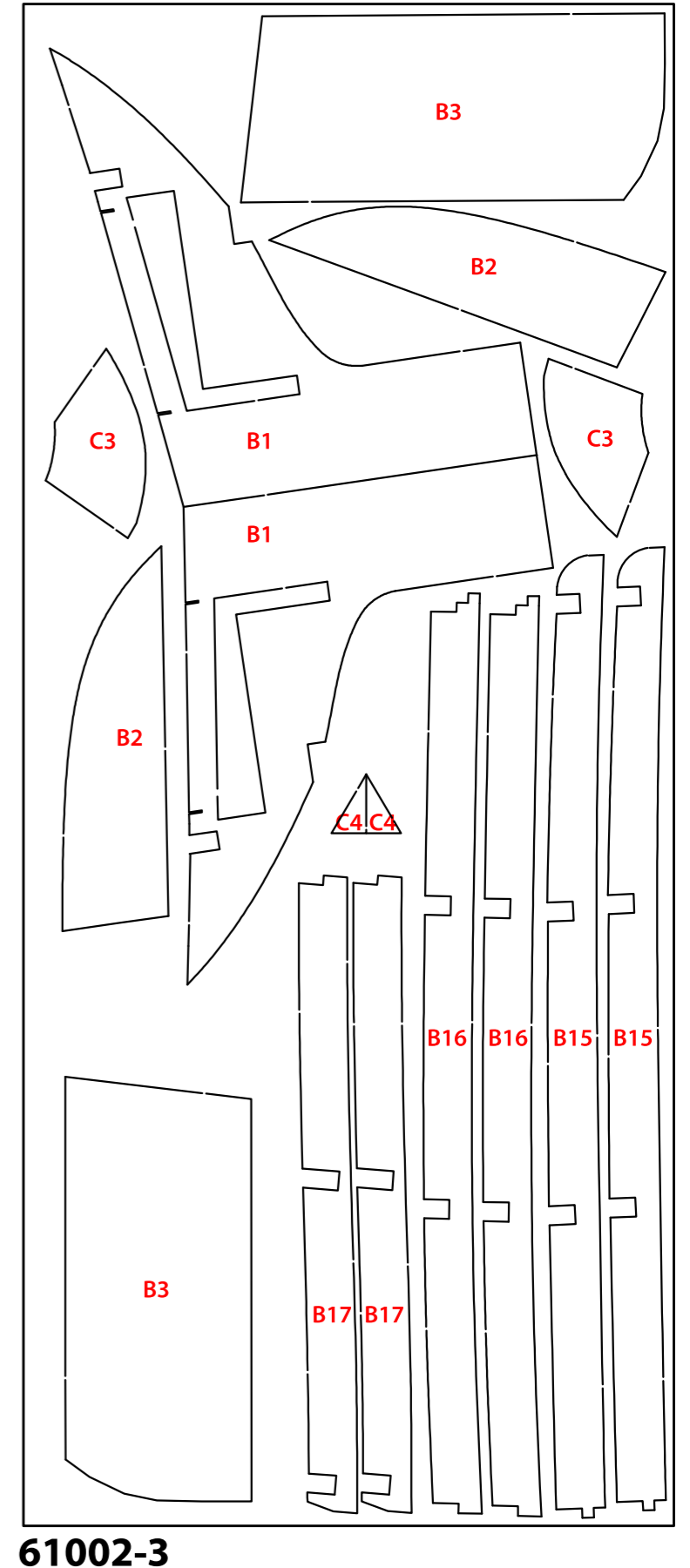
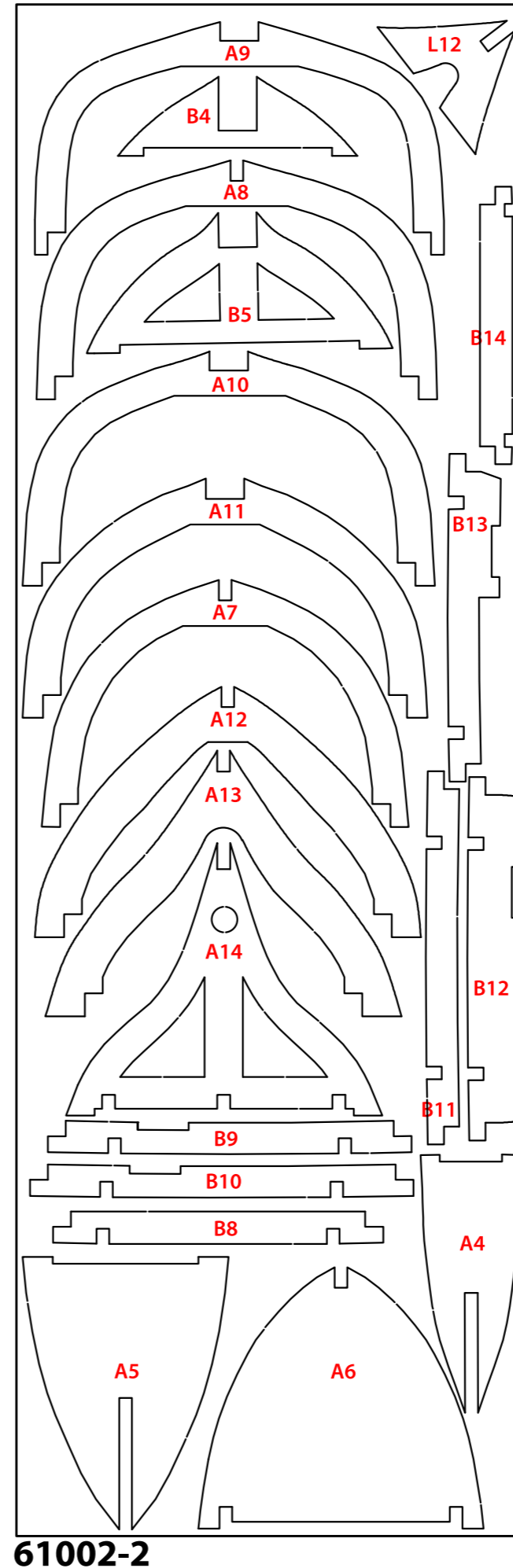
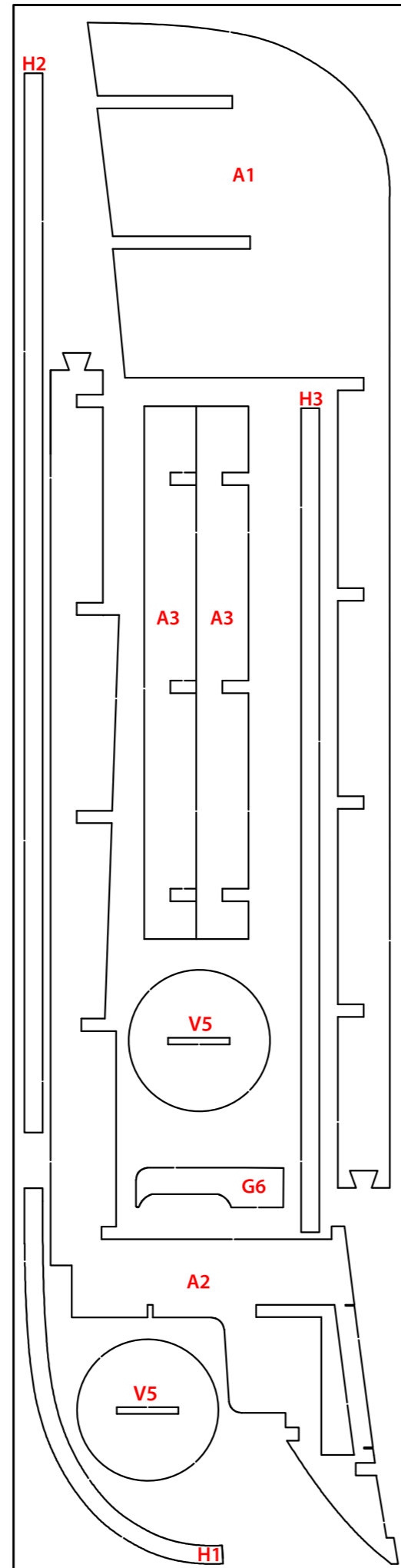
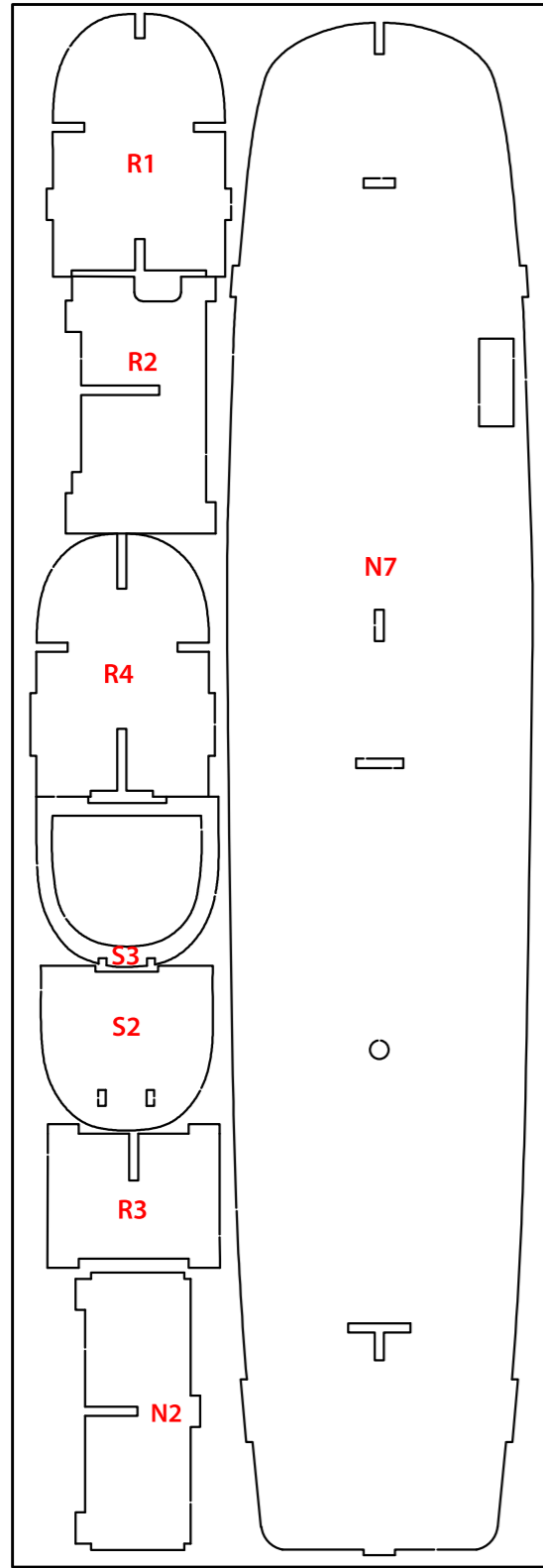

IP

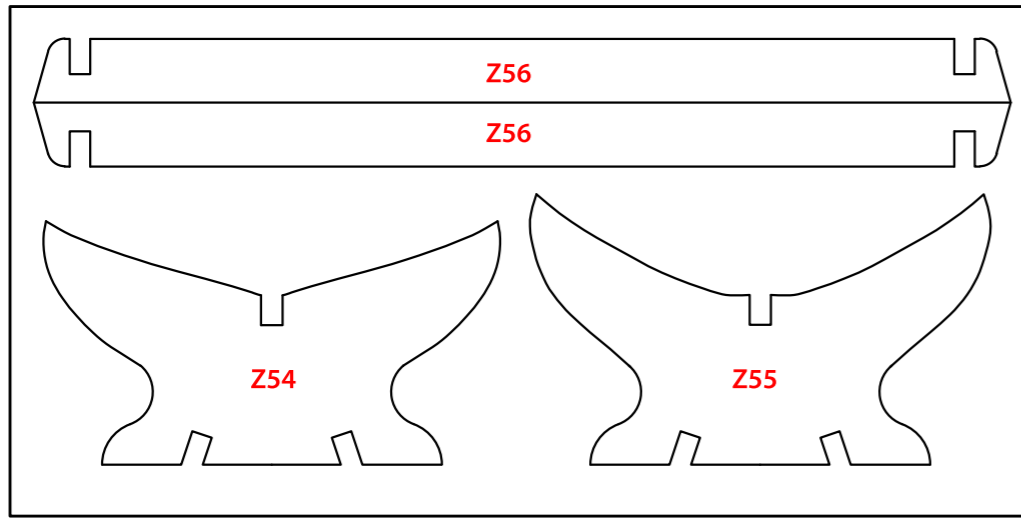

61002-13

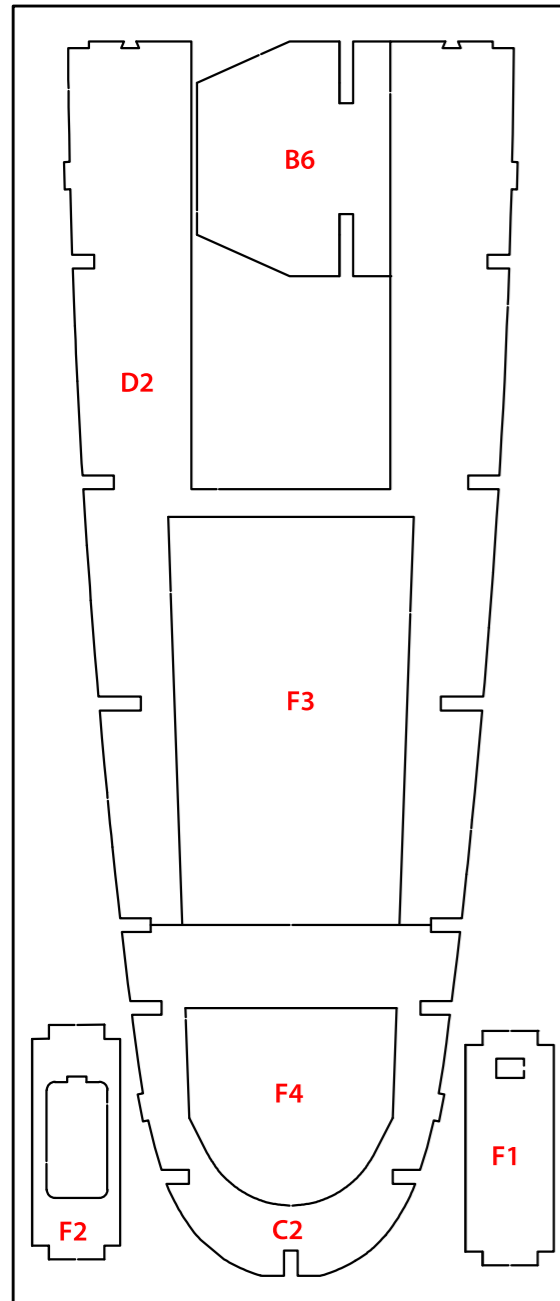

61002-4

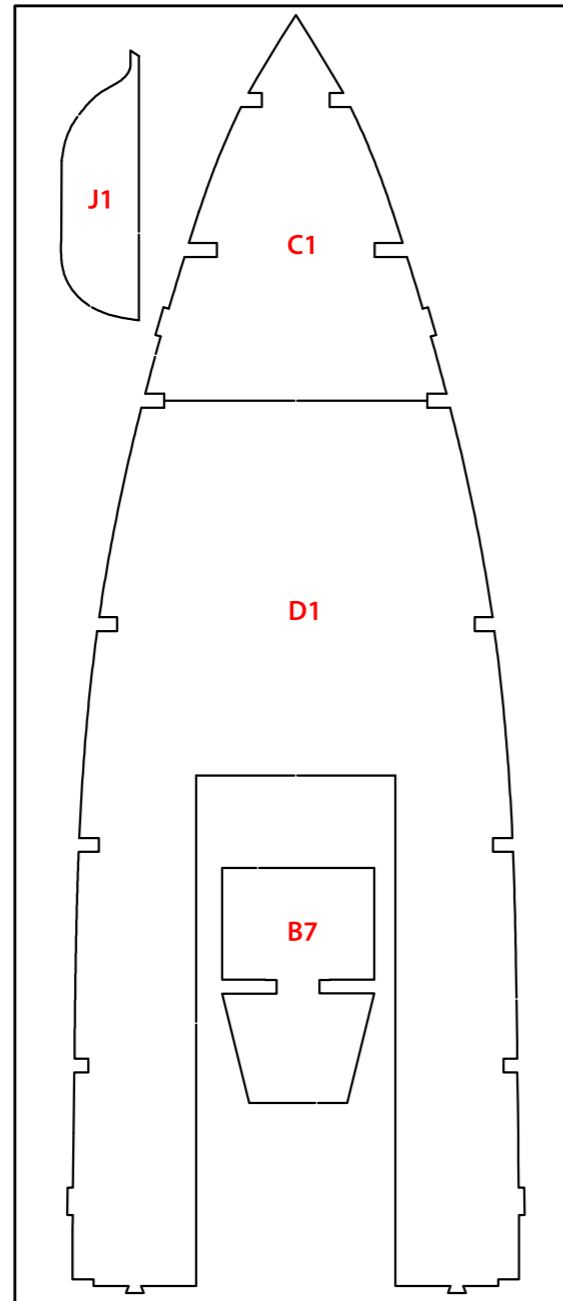

61002-5

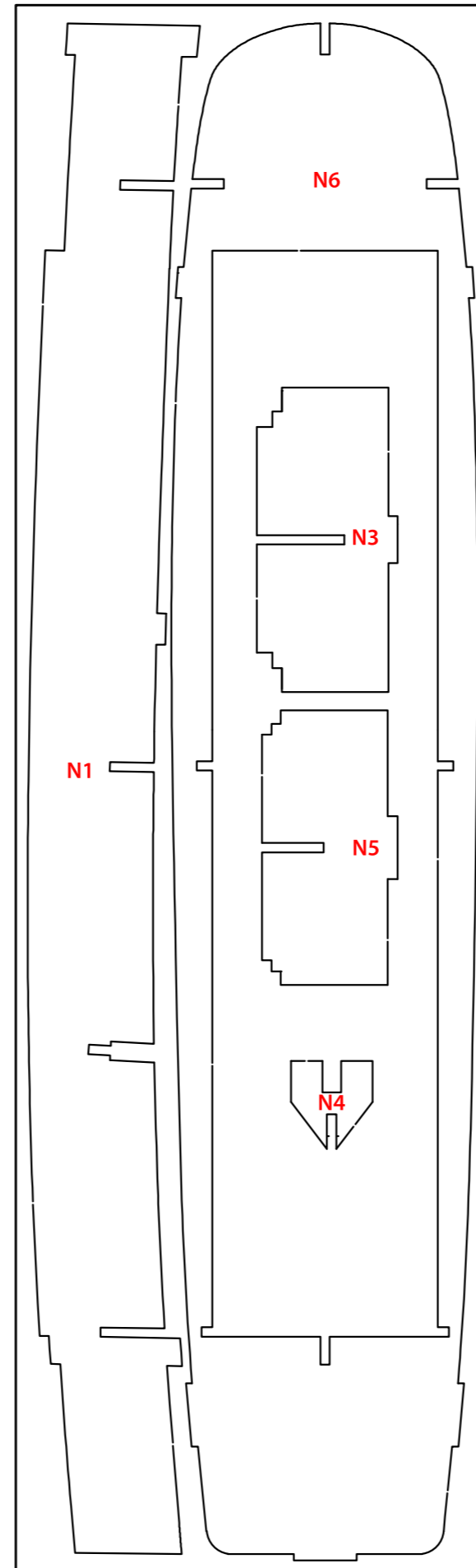

61002-9

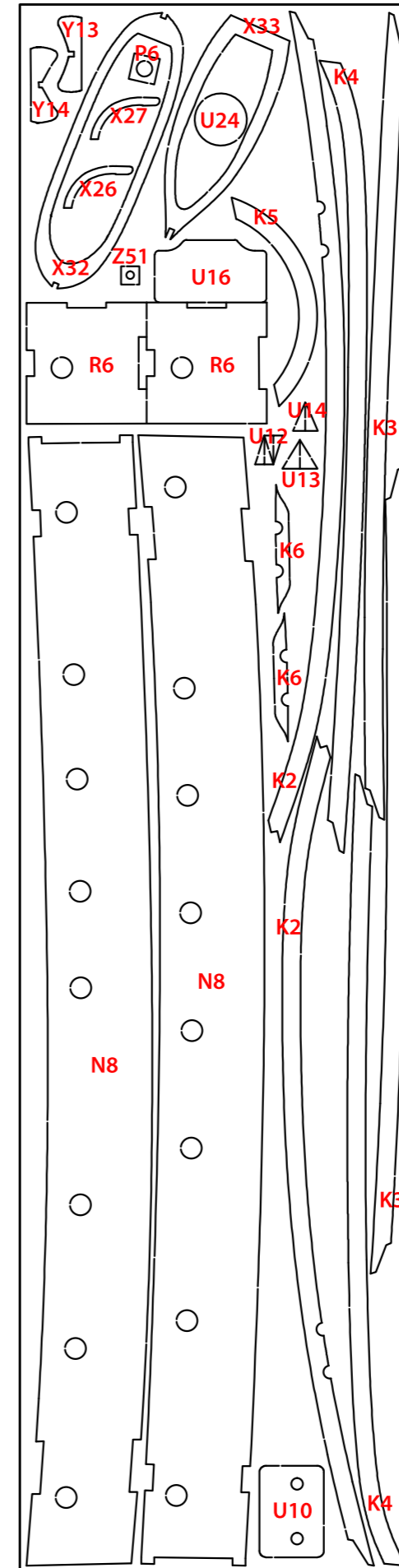

61002-7

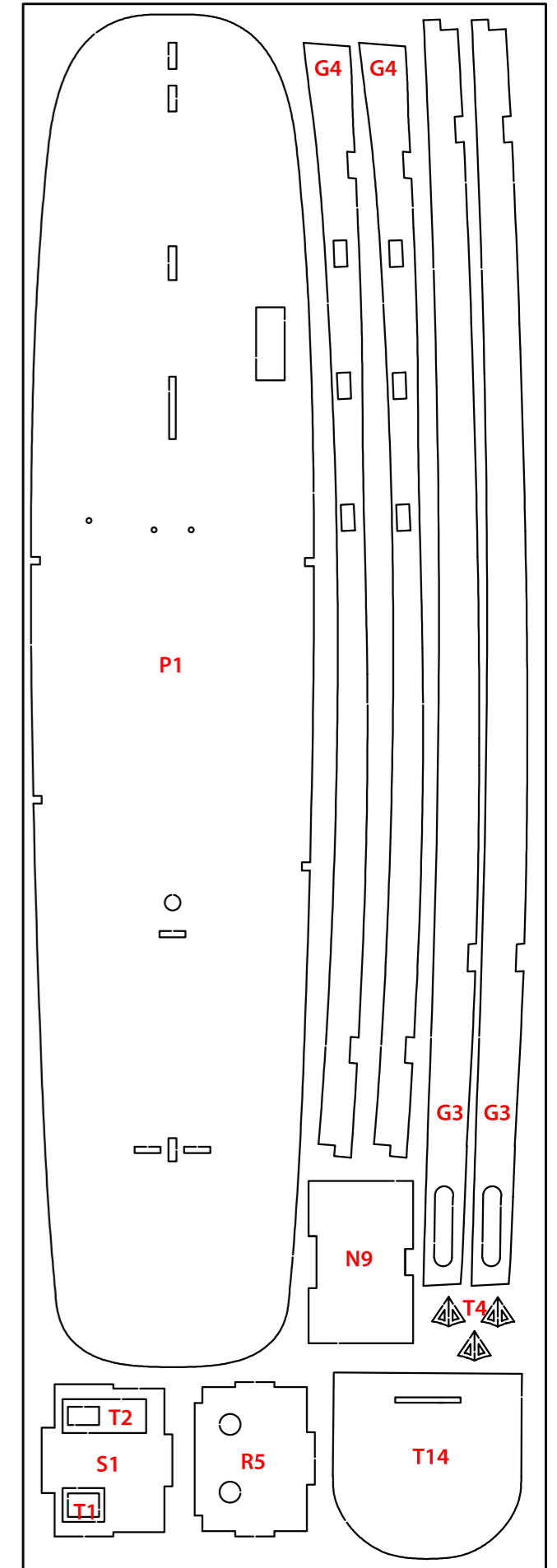

61002-6

Hercules

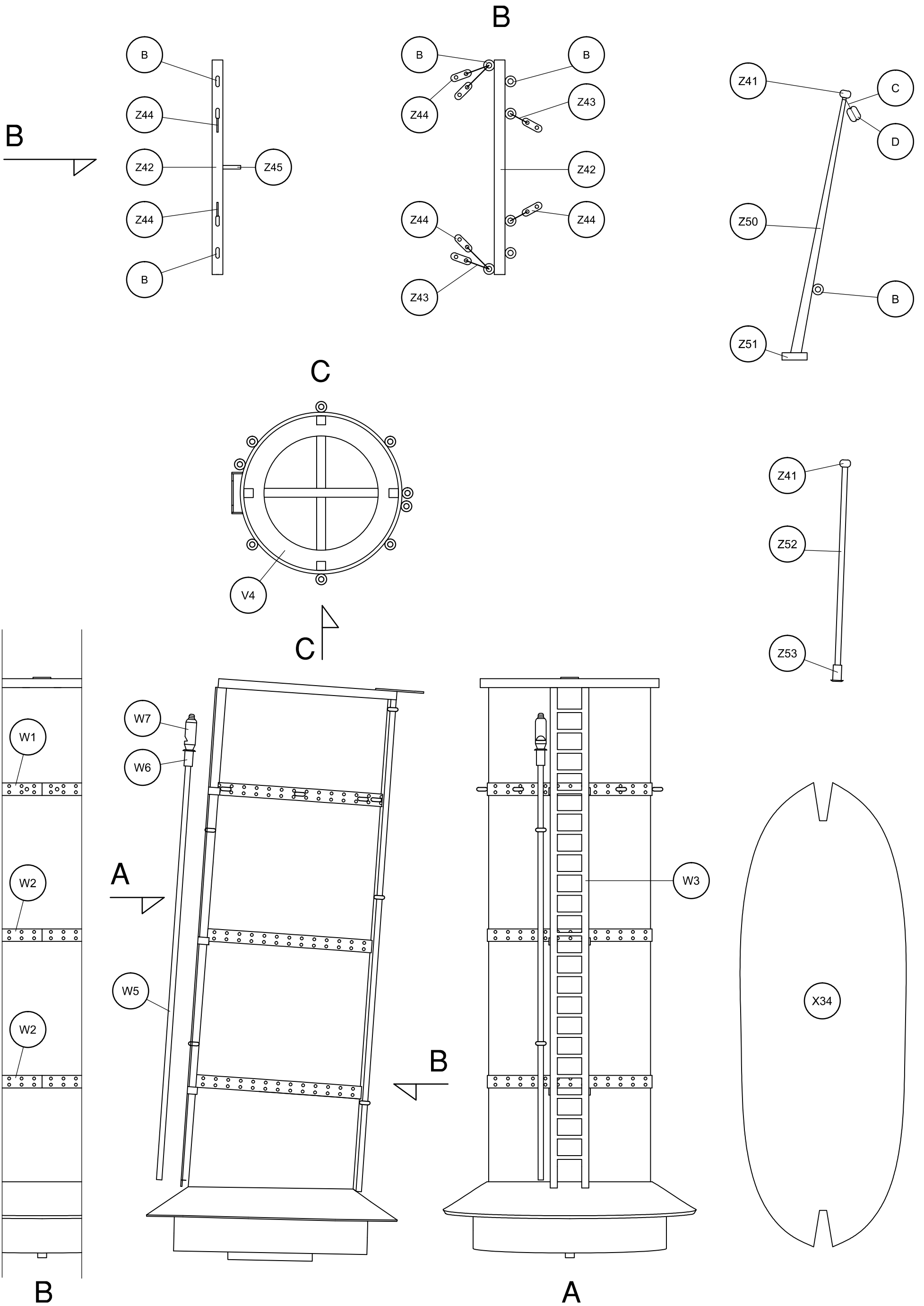

Hercules

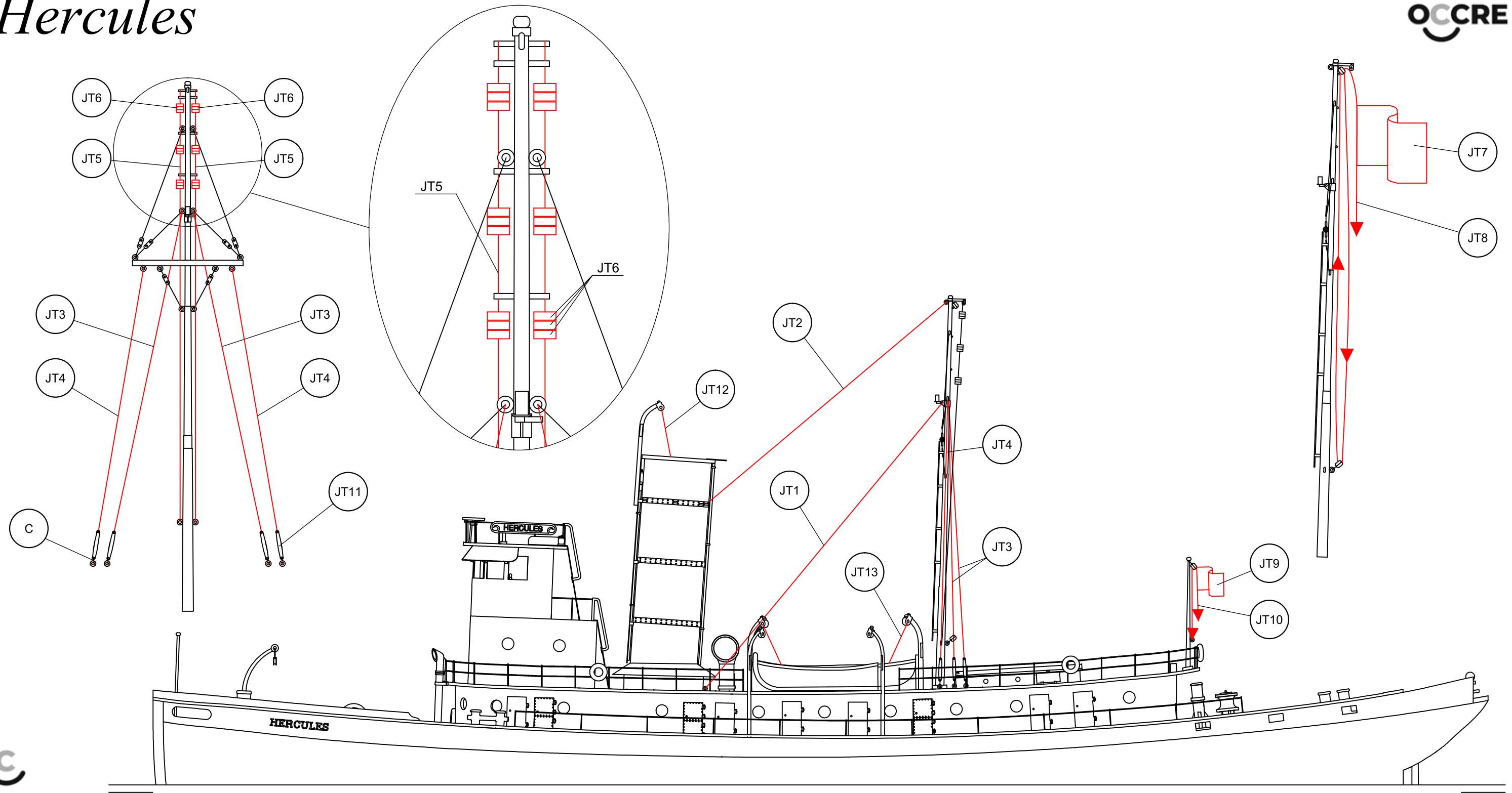

JT1	∅0,50x300	Hilo marrón / Brown thread / Fil brun / braunes Baumwollfaden / Filo marrone	JT8	∅0,15x750	Hilo crudo / Raw thread / Fil brut / Rohes Baumwollfaden / Filo crudo
JT2	∅0,50x275	Hilo marrón / Brown thread / Fil brun / braunes Baumwollfaden / Filo marrone	JT9	Preformado / Prefomed/ Préformé / Vorgeformt / Preformato	Tela / Cloth / Étoffe / Stoff / Tela
JT3	∅0,50x450	Hilo marrón / Brown thread / Fil brun / braunes Baumwollfaden / Filo marrone	JT10	∅0,15x250	Hilo crudo / Raw thread / Fil brut / Rohes Baumwollfaden / Filo crudo
JT4	∅0,50x300	Hilo marrón / Brown thread / Fil brun / braunes Baumwollfaden / Filo marrone	JT11	Preformado / Prefomed/ Préformé / Vorgeformt / Preformato	Latón / Brass / Latón / Messing / Ottone
JT5	∅0,50x350	Hilo marrón / Brown thread / Fil brun / braunes Baumwollfaden / Filo marrone	JT12	∅0,15x200	Hilo crudo / Raw thread / Fil brut / Rohes Baumwollfaden / Filo crudo
JT6	Preformado / Prefomed/ Préformé / Vorgeformt / Preformato	Madera / Wood / Bois / Holz / Legno	JT13	∅0,15x200	Hilo crudo / Raw thread / Fil brut / Rohes Baumwollfaden / Filo crudo
JT7	Preformado / Prefomed/ Préformé / Vorgeformt / Preformato	Tela / Cloth / Étoffe / Stoff / Tela	C	∅0,15x100	Hilo crudo / Raw thread / Fil brut / Rohes Baumwollfaden / Filo crudo

Hercules

PL-01

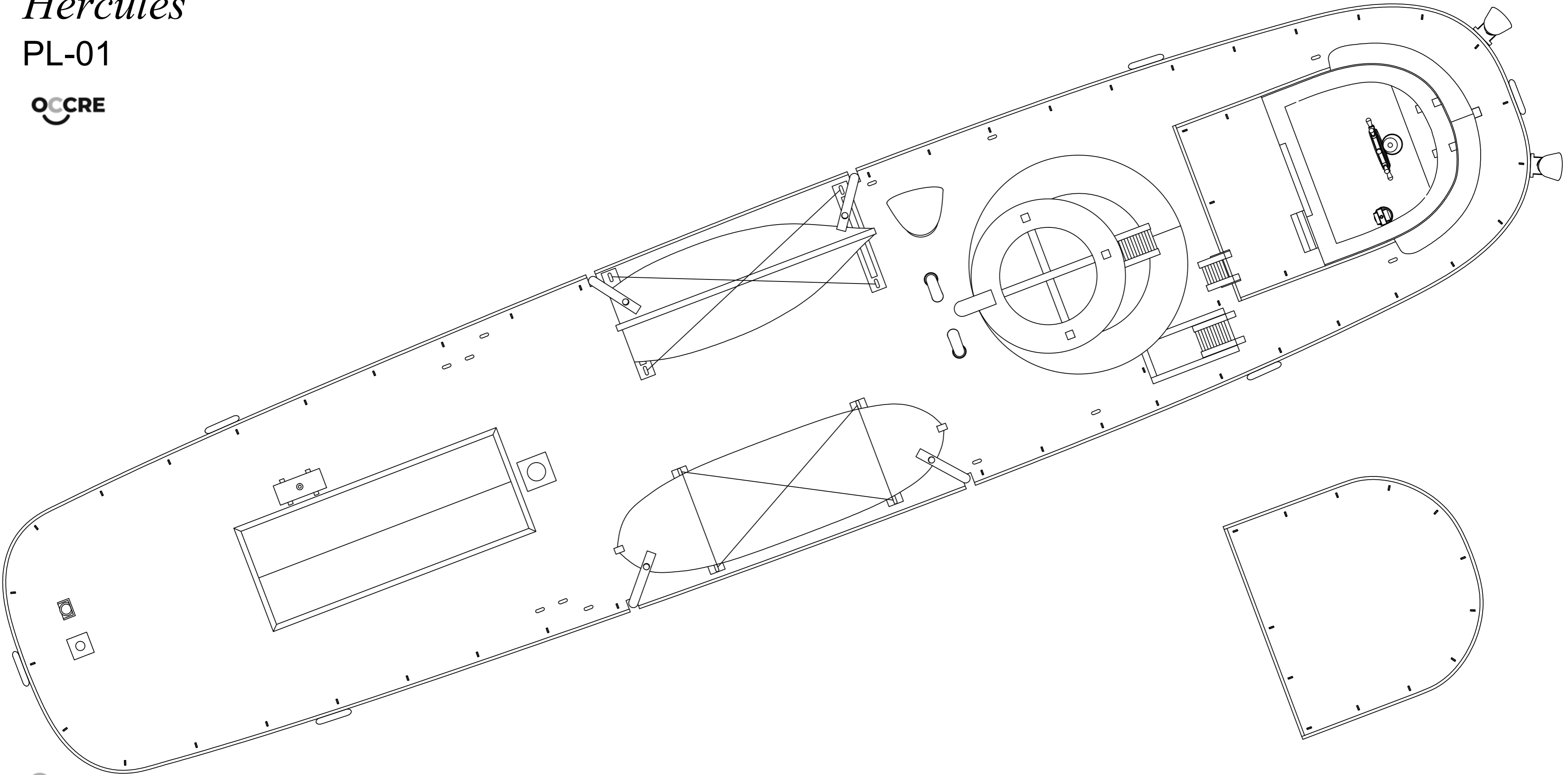

Scale 1/1

Hercules

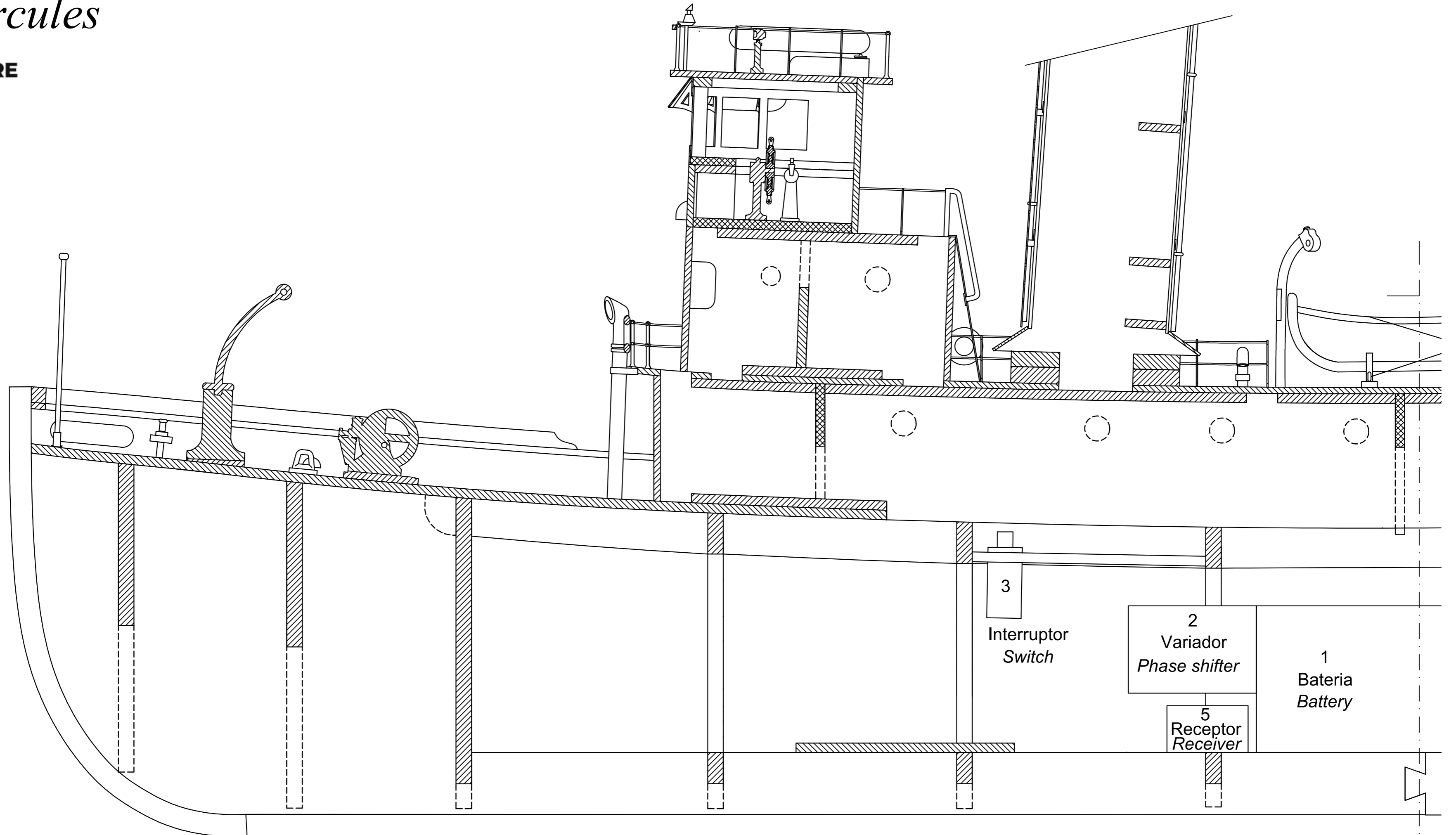

Scale 1/1

Hercules

