



### Cooling Problems

Engine overheating is most often caused by running the engine too lean or because the cooling air for the cylinder head is blocked. If the mixture is too lean, simply allow the engine to cool, richen the mixture and try it again. Bodies must have holes cut in them to allow for cooling air to circulate over the surface of the cylinder head. On most bodies, it is a good idea to cut part of the wind-shield out and part of the back window to allow for additional cooling.

### Factory Settings for Force .18

All new engines are assembled with what we will term 'factory settings'. These settings should allow almost all engines to be started up and allow for minimal adjustment for running in purposes.

Bearing this in mind, we are offering you the opportunity of re-adjusting to the 'factory settings' based on engines currently held in stock.

### Main Needle Valve – High Speed Adjustment (HSA)

Screw down until resistance is met, and no further movement is apparent. RE-OPEN 3 1/4 TURNS.

### Throttle Adjustment Screw – Idle Adjustment (IA)

Gently shut off carburettor sliding body and slowly re-open by means of adjusting screw.

ADJUST SCREW UNTIL APPROX 1 or 1 1/4mm OF APERTURE APPEARS BETWEEN THE END OF THE THROTTLE BODY AND AIR INTAKE APERTURE.

### Sub Throttle Needle Valve – Low Speed Adjustment (LSA)

With adjustment screw setting in place, close off the throttle body against the screw. Very gently screw in the needle valve until it closes off the supply fuel nozzle and is prevented from re-opening by the entry of the needle valve into the centre hole of the fuel nozzle (work with great care with this one - we are only looking for minimal frictional contact between both parts).

RE-OPEN VALVE 2 1/2 TURNS.

### Glossary of Carburettor Functions

#### Main Needle Valve (High Speed)

The main needle mixture screw controls how much fuel enters the engine during mid- to high-speed operation. The screw is turned clockwise to lean (less fuel) and anti-clockwise to richen (more fuel)

#### Sub Throttle Valve (Low Speed)

This screw meters the fuel at low speeds. The low-speed mixture screw is located in the end of the carburetor, inside the throttle arm.

This screw controls how much fuel enters the engine at idle and low throttle. This adjustment will smooth the idle and improve the acceleration to mid speed. Make this adjustment with the throttle closed, after setting the idle. The screw is turned clockwise to lean (less fuel) and anti-clockwise to richen (more fuel)

#### Throttle Adjustment Screw

The throttle adjustment screw regulates the throttle opening to control the idle speed. The screw is turned clockwise for a higher idle speed and anti-clockwise for a lower idle speed.

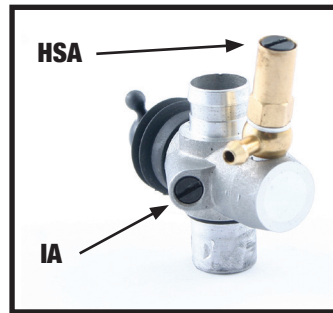

## FORCE .18 PULL START ENGINE

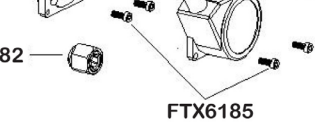
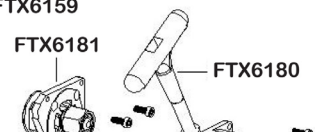
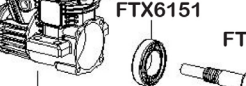
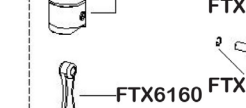
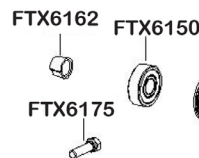
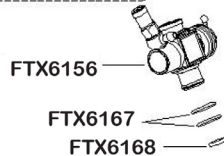
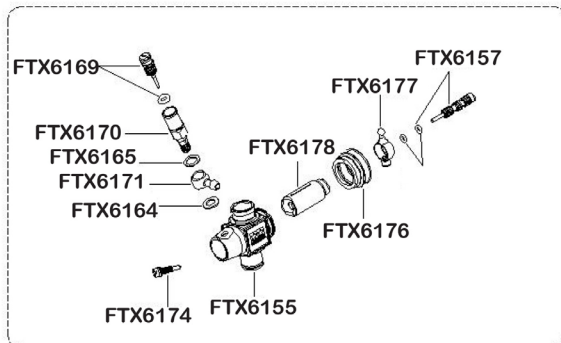

FTX6150	FTX FORCE FG.18 BALL BEARING
FTX6151	FTX FORCE FG.18 BALL BEARING
FTX6152	FTX FORCE FG.18 CRANKCASE
FTX6153	FTX FORCE FG.18 BURN ROOM(UNDERHEAD)
FTX6154	FTX FORCE FG.18 CASTING CYLINDER HEAD
FTX6155	FTX FORCE FG.18 COMPOSITE CARB MAIN BODY
FTX6156	FTX FORCE FG.18 COMPOSITE CARB COMPLETELY SET
FTX6157	FTX FORCE FG.18 IDLE NEEDLE W/O RING
FTX6158	FTX FORCE FG.18 CYLINDER SLEEVE/PISTON
FTX6159	FTX FORCE FG.18 CYLINDER/PISTON/CONNECTING ROD SET
FTX6160	FTX FORCE FG.18 CONNECTING ROD
FTX6161	FTX FORCE FG.18 90 CRANKSHAFT
FTX6162	FTX FORCE FG.18 DRIVE BRASS WASHER
FTX6163	FTX FORCE FG.18 GLOW PLUG B4 HOT
FTX6164	FTX FORCE FG.18 WASHER,1PC
FTX6165	FTX FORCE FG.18 WASHER,1PC
FTX6166	FTX FORCE FG.18 CYLINDER HEAD WASHER 1pc
FTX6167	FTX FORCE FG.18 CARBURETOR O/R RING, 2pcs
FTX6168	FTX FORCE FG.18 O RING 1pc
FTX6169	FTX FORCE FG.18 MAIN NEEDLE W/O RING
FTX6170	FTX FORCE FG.18 MAIN NEEDLE VALVE HUB
FTX6171	FTX FORCE FG.18 FUEL NYLON
FTX6172	FTX FORCE FG.18 PISTON GUIDEON PIN
FTX6173	FTX FORCE FG.18 CYLINDER HEAD BOLT, 4pcs
FTX6174	FTX FORCE FG.18 ADJUST SCREW
FTX6175	FTX FORCE FG.18 CARB PINCH BOLT
FTX6176	FTX FORCE FG.18 DUST COVER
FTX6177	FTX FORCE FG.18 THROTTLE SCREW CAP
FTX6178	FTX FORCE FG.18 THROTTLE & COUNTER NEEDLE VALVE
FTX6179	FTX FORCE FG.18 O/R PIN SNAP RING, 2pcs
FTX6180	FTX FORCE FG.18 PLASTIC A PARTS ASSEMBLY W/SCREWS
FTX6181	FTX FORCE FG.18 B PARTS ASSEMBLY W/SCREWS
FTX6182	FTX FORCE FG.18 ONE WAY BEARING SET
FTX6183	FTX FORCE FG.18 STARTING PIN
FTX6184	FTX FORCE FG.18 PRESSURE SPRING
FTX6185	FTX FORCE FG.18 SCREWS, 4pcs



# EXPLODED DIAGRAM PARTS LISTING

## FRONT SHOCK ABSORBERS

## REAR SHOCK ABSORBERS

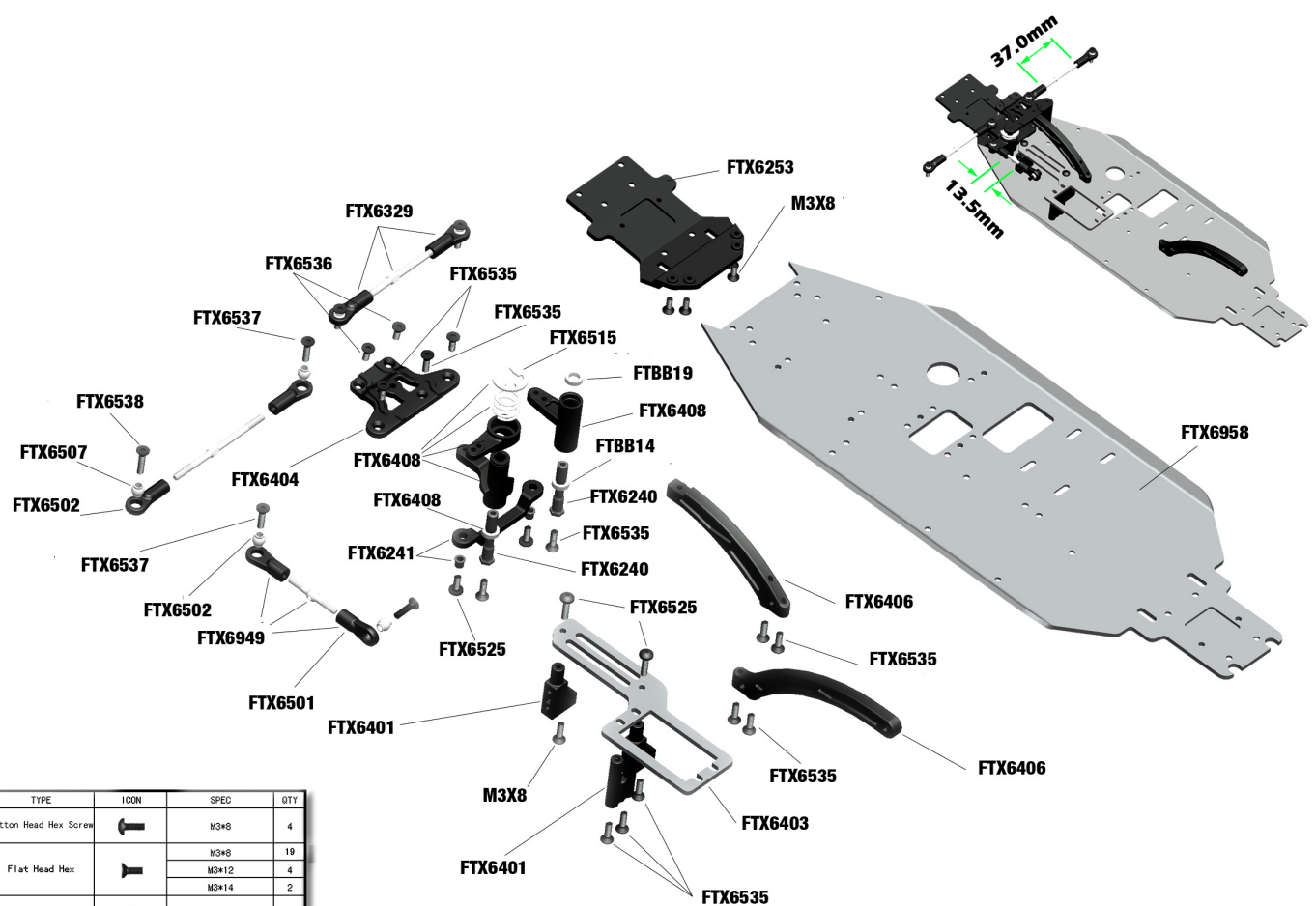
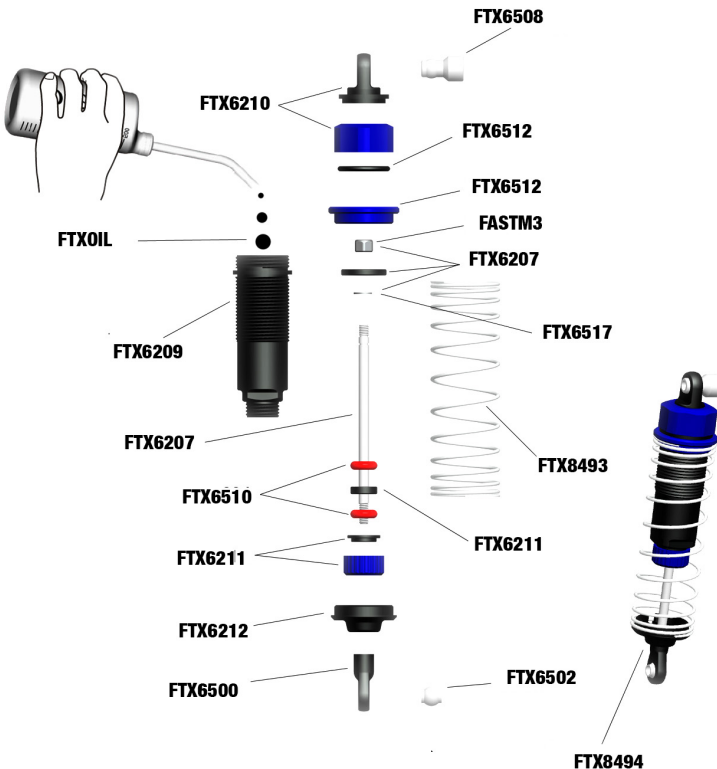
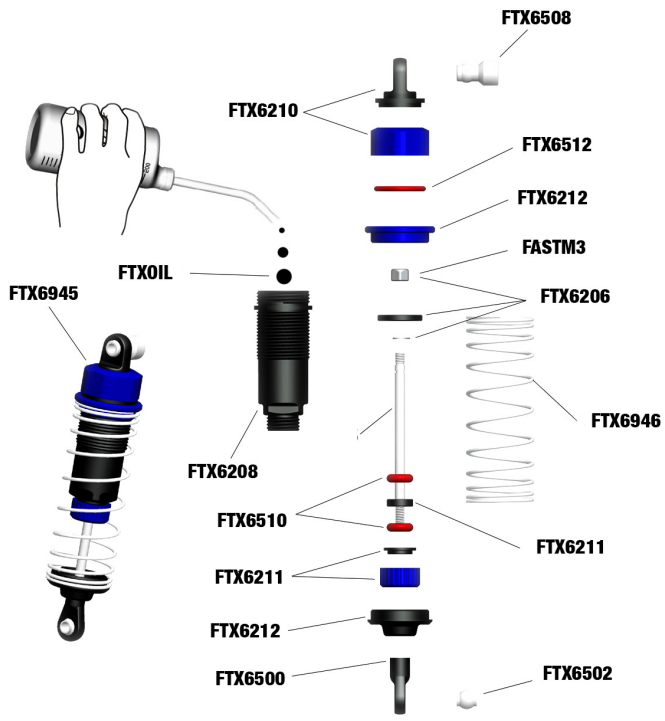

TYPE	ICON	SPEC	QTY
Button Head Hex Screw		M3x8	4
Flat Head Hex		M3x8	19
		M3x12	4
		M3x14	2
E clip		ø8	1
Ball Bearing		ø8x5x2.5	3



**B O M**

TYPE	ICON	SPEC	QTY
Round Head Self Tapping Hex Screw		2#6	4
Button Head Hex Screw		M3#8	4
Cap Head Hex Screw		M3#15	2
		M3#28	5
Flat Head Hex		M3#10	1
Set Screw		M4#4	1
Washer		ø6#x3.1#0.2	1
Nylon Lock Nut		M3	5
O'Ring		Ø31# Ø2	1
Ball Bearing		ø10#ø5#4	2

**ENGINE ASSEMBLY**

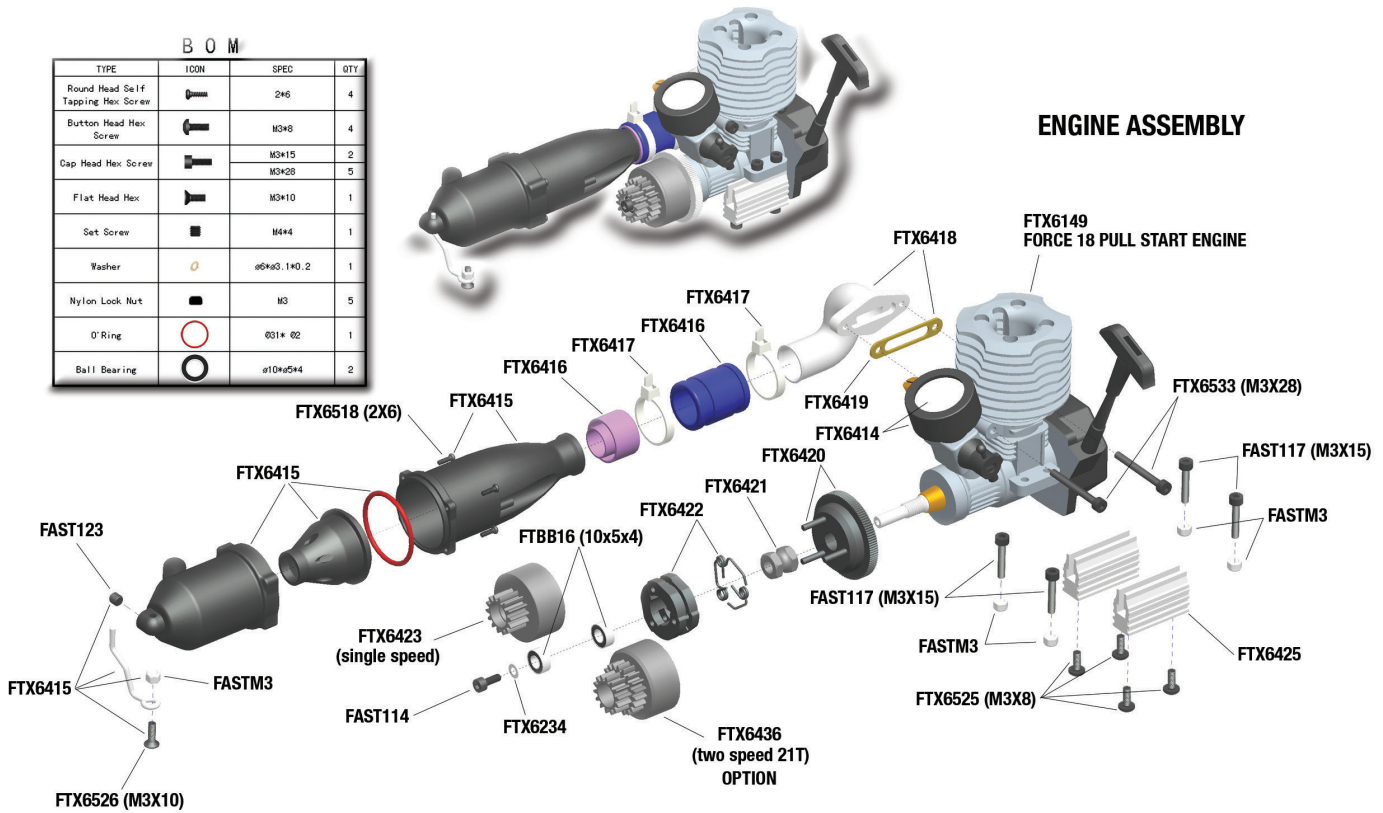

**CARNAGE SINGLE SPEED TRANSMISSION (KIT STD)**

**B O M**

TYPE	ICON	SPEC	QTY
Cap Head Hex Screw		M3#10	2
Flat Head Hex		M3#8	4
		M3#20	2
Set Screw		M3#3	1
		M4#4	2
E clip		ø4	3
Ball Bearing		ø10#ø5#4	2

**CARNAGE TWO SPEED TRANSMISSION (OPTION)**

**B O M**

TYPE	ICON	SPEC	QTY
Cap Head Hex Screw		M3#10	2
Flat Head Hex		M3#8	4
		M3#20	2
Set Screw		M3#3	1
		M4#4	4
E clip		ø4	1
One Way Bearing		Ø12#Ø6.3#6.4	1
Ball Bearing		ø10#ø5#4	3

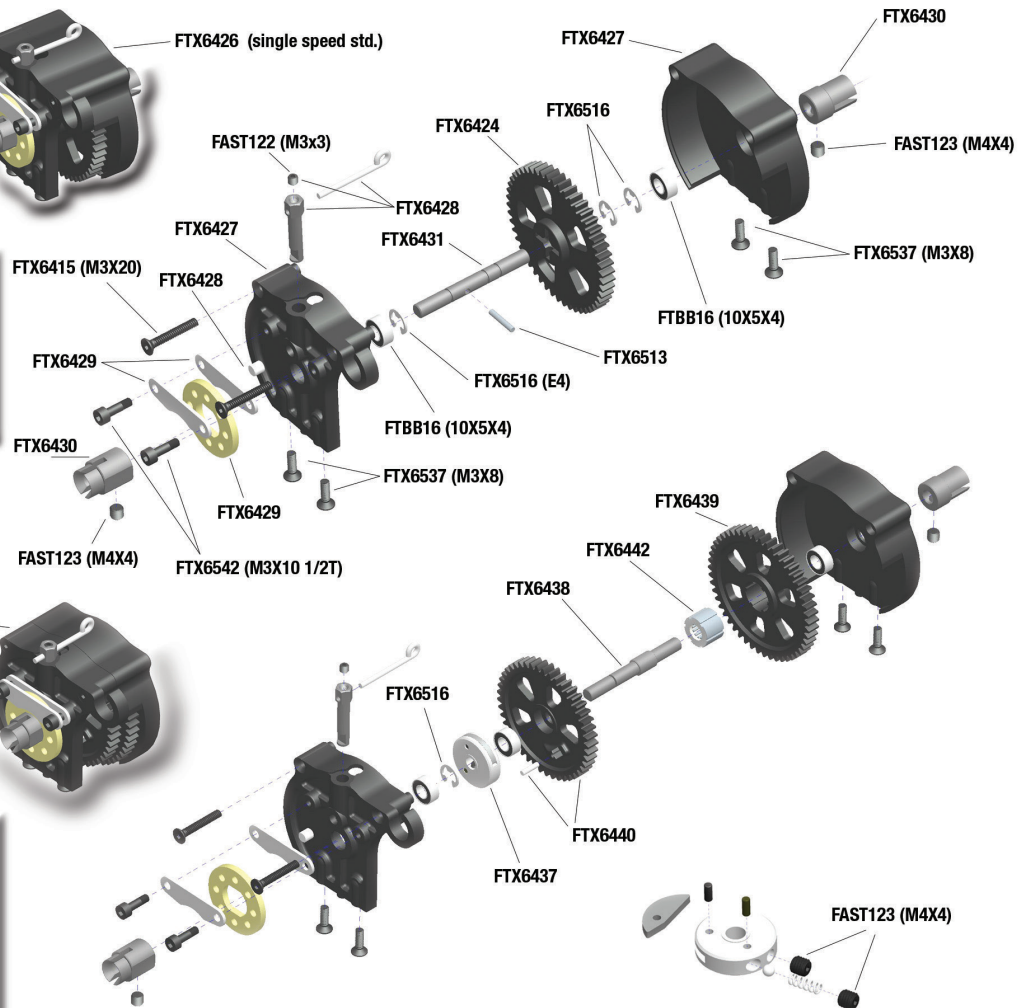

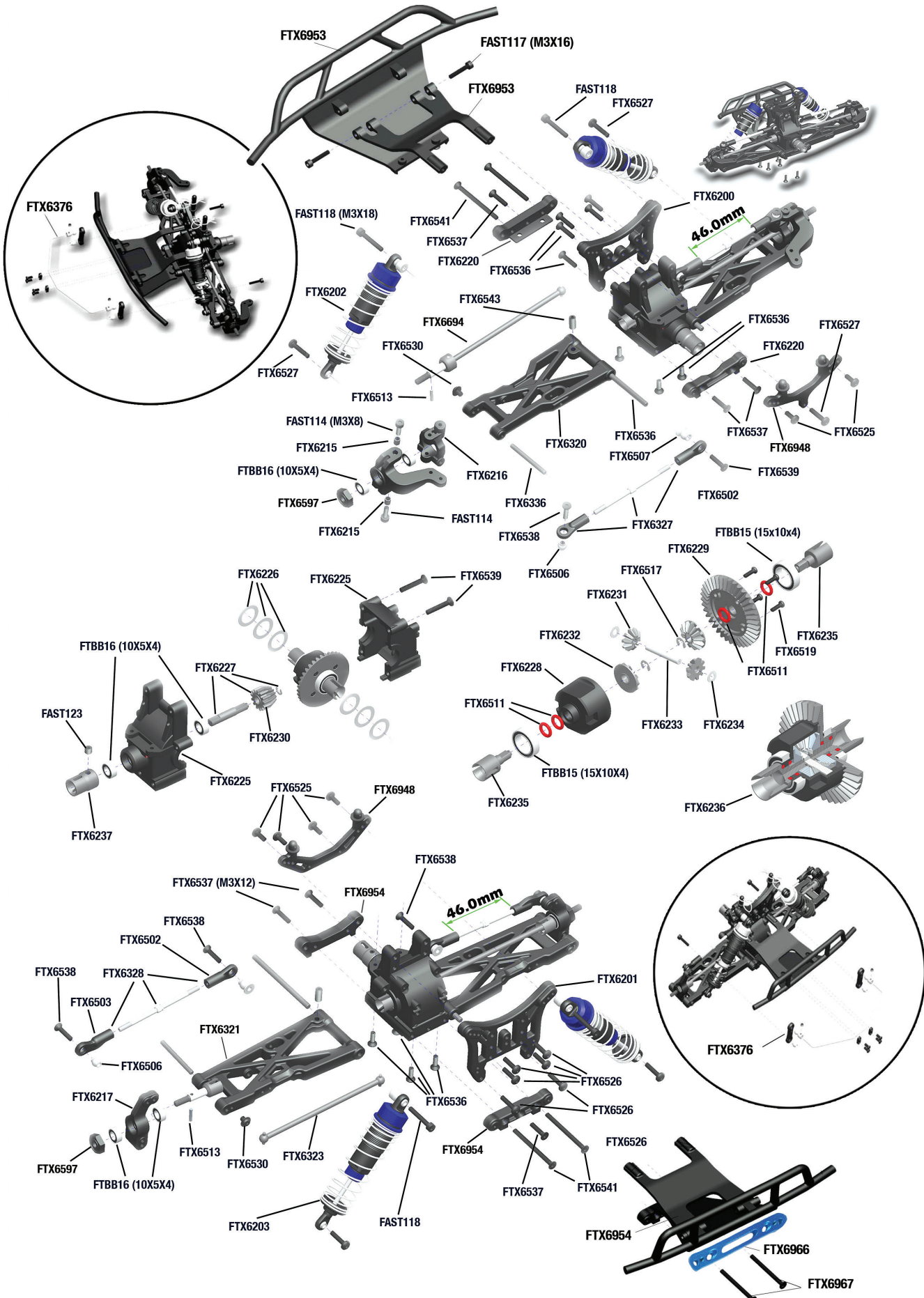

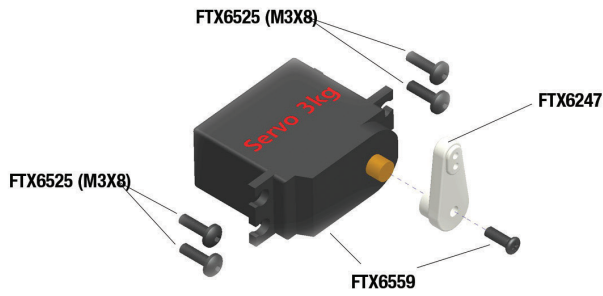

**STEERING SERVO**

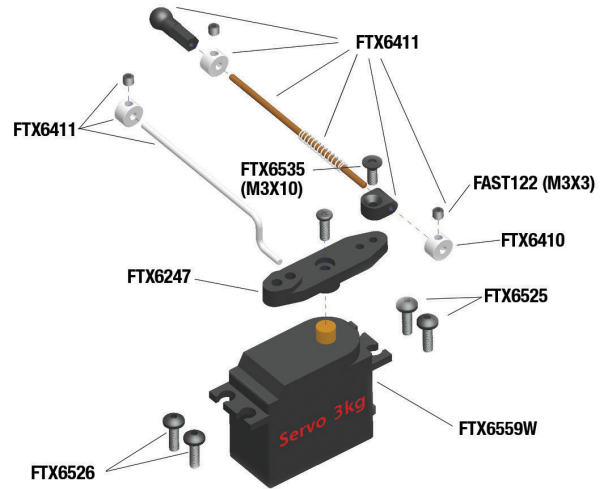
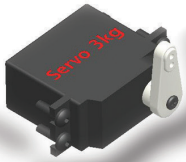

**RECEIVER ASSEMBLY**

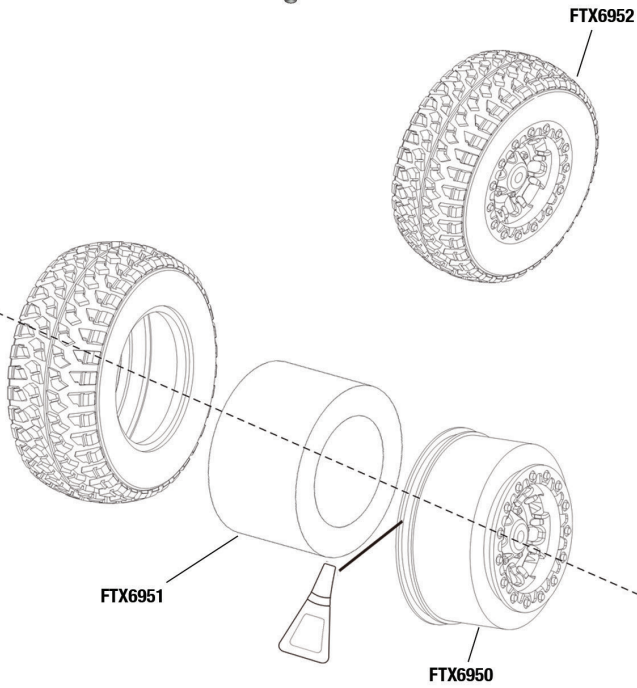
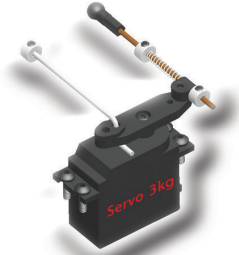
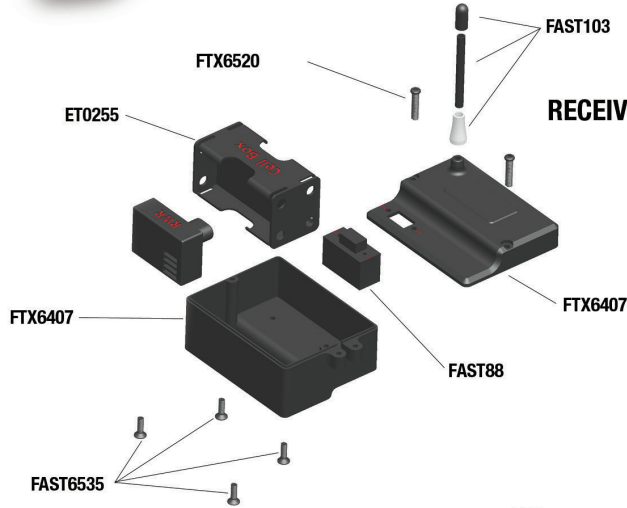

**FUEL TANK**

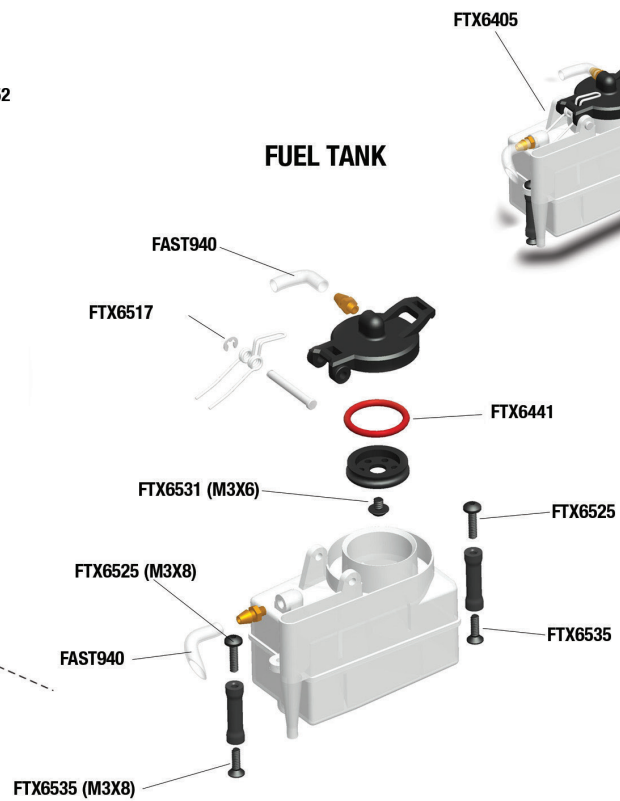





# PARTS LISTING

## PARTS LISTING

FTX6200- Front Shock Tower 1pc



FTX6201 -Rear Shock Tower 1pc



FTX6945 -Front Shocks 2pc



FTX8494 - Rear Shock Tower 2pc



FTX6946-Front Shock Spring 2pc

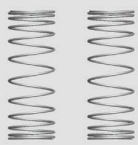

FTX8493 - Rear Shock Spring 2pc

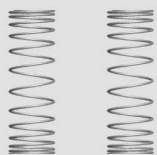

FTX6206-Front Shock Shaft & Piston  
Set 2sets



FTX6207-Rear Shock Shaft & Piston  
Set 2sets

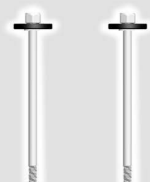

FTX6208-Front Shock Body 2pc



FTX6209 -Rear Shock body 2pc



FTX6210 -Shock Upper Cap 2sets

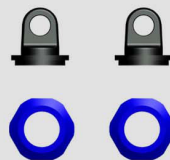

FTX6211 -Shock Lower Caps 2sets

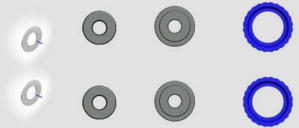

FTX6212-Shock Lower holder & Adjust  
Ring 2sets



FTX6320 -Front Lower Susp. Arm 2pc

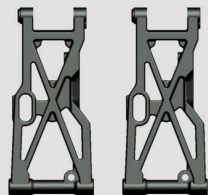

FTX6321-Rear Lower Susp. Arm 2pc

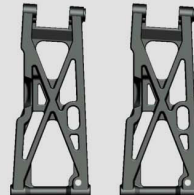

FTX6215-Steering Knuckle Arm 1set



FTX6216 -Uprights 2pc



FTX6947 -Front CVD 2pc



FTX6217-Rear Hub Carrier 2pc



FTX6213-Rear Drive Shaft 2pc



FTX6323 -Rear Dogbones 2pc



FTX6225 -Gearbox Housing Set 2pcs

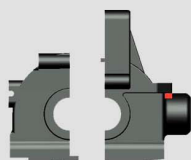

FTX6226-Diff 16T Gear Washer 6pcs

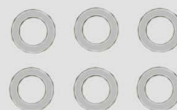









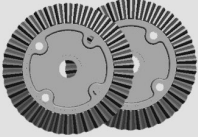
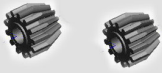
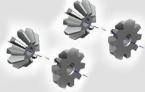
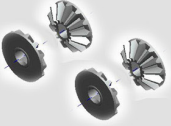

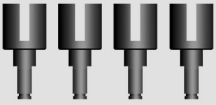

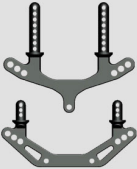

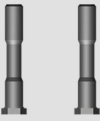
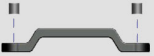
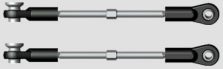

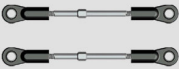
FTX6227-Diff. Drive Gear w/pin 2sets



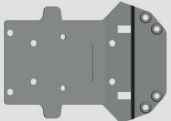

### PARTS LISTING

<p>FTX6228 -Diff Case 2pcs</p> 	<p>FTX6229 -Diff Drive Spur Gear 2pcs</p> 	<p>FTX6230-Diff Drive Gear 2pcs</p> 	<p>FTX6231-Diff Bevel Gear S. 4pcs</p> 
<p>FTX6232-Diff Bevel Gear B. 4pcs</p> 	<p>FTX6233 -Diff Pin 2pcs</p> 	<p>FTX6234 -Washer 6pcs</p> 	<p>FTX6235 -Diff Drive Cup 4pcs</p> 
<p>FTX6237-Center Coupler 3pcs</p> 	<p>FTX6948 -Body Post 2pcs</p> 	<p>FTX6408 -Servo Saver (GP) 1set</p> 	<p>FTX6240 -Servo Saver Post 2pcs</p> 
<p>FTX6241 -Steering Ackerman</p> 	<p>FTX6327-Front Upper Susp. Arm 2sets</p> 	<p>FTX6328-Rear Upper Susp. Arm 2sets</p> 	<p>FTX6329 -Steering Arm 2sets</p> 
<p>FTX6949 -Servo linkage 1set</p> 	<p>FTX6597 - Wheel hub 4pcs</p> 	<p>FAST103B-Antenna Pipe Set 2sets</p> 	<p>FTX6220 - Front Arm Holders</p> 
<p>FTX6253 -Chassis Front Part 1pc</p> 	<p>FTX6950 - Rim 2pcs</p> 	<p>FTX6951 - Tyres &amp; foam 2sets</p> 	<p>FTX6952 - Preassembled Tyres 2sets</p> 



### PARTS LISTING

<p>FTX6953 -Front bumper Set 1set</p> 	<p>FTX6954 -Rear bumper Set 1set</p> 	<p>FTX6236 -Diff Gearbox Set 1set</p> 	<p>FTX6956 -Rear suspension arm pins w/screws 2pcs</p> 
<p>FTX6419 -Manifold Gasket 6pc</p> 			<p>FTX6401-Servo &amp; Upper Plate Mounts 1set</p> 
<p>FTX6403 -Upper Plate 1pc</p> 	<p>FTX6404 -Upper Steering Plate</p> 	<p>FTX6405 -Fuel tank Set 1set</p> 	<p>FAST940 -Fuel Line 2pcs</p> 
<p>FTX6406 -Front/Rear Chassis Brace</p> 	<p>FT6407 -Receiver Box 1set</p> 	<p>FAST88 -Switch Cover 2pcs</p> 	<p>FTX6247 -Servo Horns</p> 
<p>FTX6409 -Chassis Brace mount 1pc</p> 	<p>FTX6410 -Stopper 6pcs</p> 	<p>FTX6411 -Throttle Linkage 1set</p> 	<p>FTX6957 -Central Dongbone F. 1pc</p> 
<p>FTX6149 -FC.18 Engine 1pc</p> 	<p>FTX6414 -Air filter 1Set</p> 	<p>FTX6415 -Tuned Pipe 1Set</p> 	<p>FTX6416 -Silicone Coupler 1Set</p> 



### PARTS LISTING

<p>FTX6417 -Zip Tie 6pcs</p> 	<p>FTX6418 -Manifold 1Set</p> 	<p>FTX6420 -Flywheel 1pc</p> 	<p>FTX6421 -Clutch Nut 2pcs</p> 
<p>FTX6422-Clutch Shoes &amp; Springs</p> 	<p>FTX6423 -Clutch Bell (14T) 1pc</p> 	<p>FTX6436-Clutch Bell (two speed) 1pc</p> 	<p>FTX6425 -Engine mount 2pcs</p> 
<p>FTX6426-Central Transmission Complete 1Set (Single Speed)</p> 	<p>FTX6427-Central Transmission Bulkheads 2pcs</p> 	<p>FTX6428 -Brake Post 1Set</p> 	<p>FTX6429 -Brake Set 1set</p> 
<p>FTX6430 -Brake Cup 2pcs</p> 	<p>FTX6431-Single Speed Shaft w/pin</p> 	<p>FTX6424-50T Gear (Single Speed) 1pc</p> 	<p>FTX6958-N1/N2 Chassis Plate 1pc</p> 
<p>FTX6959-Central Dongbone R. 1pc</p> 	<p>FTX8300 - Roll cage Top Frame</p> 	<p>FTX8301 - Roll cage side Frame 2pcs</p> 	<p>FTX8302 - Roll cage Front 1pc</p> 
<p>FTX8303 - Roll cage rear plate 1pc</p> 	<p>FTX8307 - Roll cage window frame 1pc</p> 	<p>FTX6960 - Spare wheel support 1pc</p> 	<p>FTX8336B - Driver helmet 2pcs FTX8336R</p> 













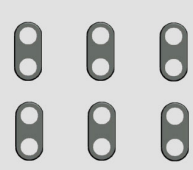





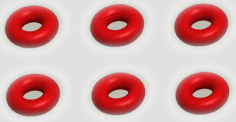
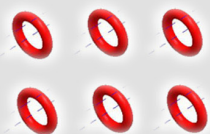

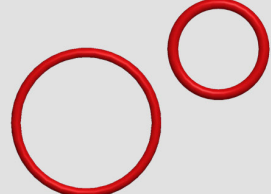
### PARTS LISTING

<p>FTX6376 -Sway Bar 2Sets</p> 	<p>FTX6500 -Shock Ball End 6pcs</p> 	<p>FTX6501 -Servo Link Ball End 6pcs</p> 	<p>FTX6551-Body Clip (Small Size) 6pcs</p> 
<p>FTX6550 -Body Clip (Medium Size) 6pcs</p> 	<p>FTX6537 -Flat Head Hex Screw M3*12 6p</p> 	<p>FTX6538 -Flat Head Hex Screw M3*14 6p</p> 	<p>FTX6540 -Flat Head Hex Screw M3*20 6p</p> 
<p>FTX6541 -Flat Head Hex Screw M3*36 6p</p> 	<p>FTX6539 -Flat Head Hex Screw M3*18 3p</p> 	<p>FTX6961 -Flat Head Hex Screw M4*10 6p</p> 	<p>FTX6962 - Body supporting bar 1set</p> 
<p>FTX6963 - Roll cage spacer 14pcs</p> 	<p>FTX8337- Driver Blister set w/decal</p> 	<p>FTX6964 - clear body</p> 	<p>FTX6965B - Printed body(Blue)</p> 
<p>FTX6965O - Printed body(orange)</p> 	<p>FTX6966 Rear bumper Fix plate(alloy) w/ screws 2pcs</p> 	<p>FTX6967 - Flat hex screw M3*40 6pcs</p> 	<p>ET0255 - Battery Case 1pc</p> 
<p>ET0873- Receiver Switch 1pc</p> 	<p>FTX6559W - 3kg Servo</p> 	<p>ET1106 - Etronix EX3G Radio Set</p> 	<p>ET1152 - Etronix 2.4Ghz Receiver</p> 

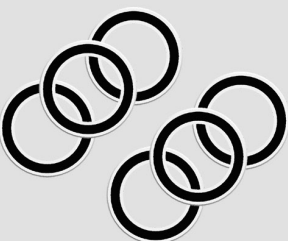
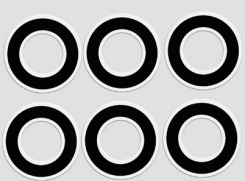
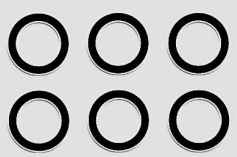
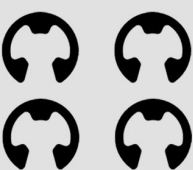

















### PARTS LISTING

<p>FTX6502-Steering Linkage Ball End 6pcs</p> 	<p>FTX6503-Rear Upper Linkage Ball End 6pcs</p> 	<p>FTX6504-Sway Bar Fix Plate 6pcs</p> 	<p>FTX6505-Sway Bar Holders 6pcs</p> 
<p>FTX6502-Ball A 6pcs</p> 	<p>FTX6507-Ball B 6pcs</p> 	<p>FTX6508-Ball C 6pcs</p> 	<p>FTX6509-Ball D 6pcs</p> 
<p>FTX6510 -Shock O-ring (Lower) 6pcs</p> 	<p>FTX6511-Diff O-ring Seal 6pcs</p> 	<p>FTX6512-Shock O-ring (upper) 6pcs</p> 	<p>FTX6441-Tuned Pipe Seal &amp; Fuel Tank Seal 1set</p> 
<p>FTX6513-Pin <math>\phi</math>2*10 6pcs</p> 	<p>FTX6514-Pin <math>\phi</math>2*11 6pcs</p> 	<p>FTX6336-Hinge Pins (long &amp; short) 2sets</p> 	<p>FTX6968-One Way Bearing 3pcs</p> 
<p>FTBB10-Ball Bearing 15*10*4 1pcs</p> 	<p>FTB120-Ball Bearing 10*5*4 2pcs</p> 		<p>FTBB14-Ball Bearing 8*5*2.5 1pcs</p> 
<p>FTX6515-E clip-8mm 4pc</p> 	<p>FTX6516-E clip-4mm 6pc</p> 	<p>FTX6517-E clip-2.5mm 6pc</p> 	<p>FASTM3-Nylon Lock Nut M3 6pc</p> 

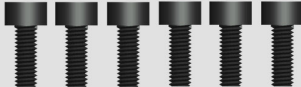
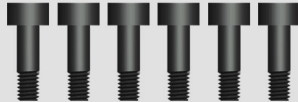
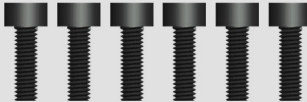
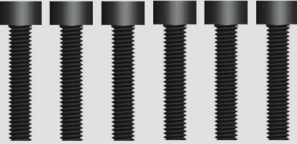
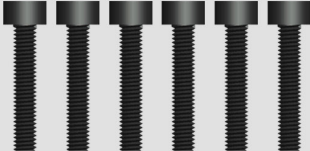
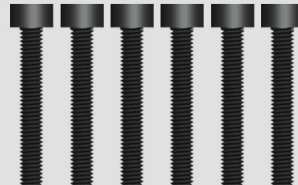
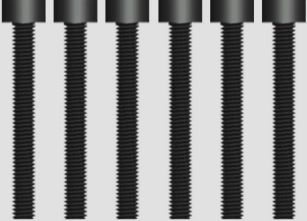
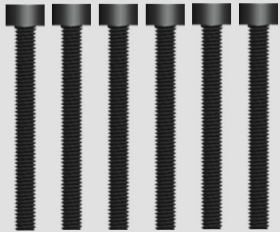

### PARTS LISTING

<p>FTM4BF-Nylon Lock Nut-M4 6pc</p> 	<p>FTX6518-Round Head Self Tapping Hex Screw 2*6 4pcs</p> 	<p>FTX6519-Round Head Self Tapping Hex Screw 2*10 6pc</p> 	<p>FTX6520-Round Head Self Tapping Hex Screw 3*15 8pc</p> 
<p>FTX6522 -Round Head Self Tapping Hex Screw M3*6 6pc</p> 	<p>FTX6525 -Button Head Hex Screw M3*8 6pc</p> 	<p>FTX6526-Button Head Hex Screw M3*10 6pc</p> 	<p>FTX6527 -Button Head Hex Screw M3*12 6pc</p> 
<p>FTX6528-Button Head Hex Screw M3*14 6pc</p> 	<p>FTX6530-Ring Self Tapping Screw 3*4 4pc FTX6531-Ring Self Tapping Screw 3*6 6pc</p> 	<p>FAST122 -Set Screw M3*3 6pc</p> 	<p>FAST123A -Set Screw M4*4 6pc</p> 
<p>FTX6543 -Button Head Hex Screw M4*10 6pc</p> 	<p>FAST114-Cap Head Hex Screw M3*8 6pc</p> 	<p>FAST6542 -Cap Head Hex Screw M3*10 6pc</p> 	<p>FAST115 -Cap Head Hex Screw M3*10 6pc</p> 
<p>FTX6532 -Cap Head Hex Screw M3*14 6pc</p> 	<p>FAST117 -Cap Head Hex Screw M3*16 6pc</p> 	<p>FAST118 -Cap Head Hex Screw M3*18 6pc</p> 	<p>FAST119 -Cap Head Hex Screw M3*25 6pc</p> 
<p>FTX6533 -Cap Head Hex Screw M3*28 6pc</p> 	<p>FTX6535-Flat Head Hex M3*8 6pc</p> 	<p>FTX6536-Flat Head Hex Screw M3*10 8pc</p> 	<p>FTX6523 - Flat Head Hex Self Screw 3x10 8pc</p> 



### UPGRADE OPTION PARTS LISTING

<p>FTX6351 - Front Shock Plate (Carbon) 1Set</p> 	<p>FTX6352 - Rear Shock Plate (Carbon) 1Set</p> 	<p>FTX6355 -Body Post (AL) 2pc</p> 	<p>FTX6971 -Front Shocks(AL)2pcs</p> 
<p>FTX8495 -Rear Shocks(AL)2pcs</p> 	<p>FTX6358 - Front Lower Susp. Arm (AL) 2pc</p> 	<p>FTX6359 -Rear Lower Susp. Arm (AL) 2pc</p> 	<p>FTX6360- Steering Ackerman (AL) 1pc</p> 
<p>FTX6312 - Front Susp. Holders (AL) 1Set</p> 	<p>FTX6378 - Front &amp; Rear Brace(AL) (AL) 1Set</p> 	<p>FTX6435 - 2-speed gearbox</p> 	<p>FTX6360- Rear Hub Carrier (AL) 2pc</p> 
<p>FTX6379 -Front Top Plate (Carbon) 1pc</p> 		<p>FTX6365W -Wheel hub (Al) 4pcs</p> 	<p>FTX6380 - Upper Plate(AL) 1pc</p> 
<p>FTX6381 - Tuned Pipe (AL) 1Set</p> 	<p>FTX6382 - Chassis Brace mount (AL) 1pc</p> 	<p>FTX6436 -Clutch Bell (two speed) 1pc</p> 	<p>FTX6367 - Alum Steering Arm 2pc</p> 
<p>FTX6368 - Alum Knuckle Arm 2pc</p> 	<p>FTX6361 - Alloy front suspension holders 1set(Optional)</p> 	<p>FTX6970 - Alloy rear suspension holders 1set(Optional)</p> 	